

X SERIES

---

# Pump Manual

CANNED MOTOR PUMP

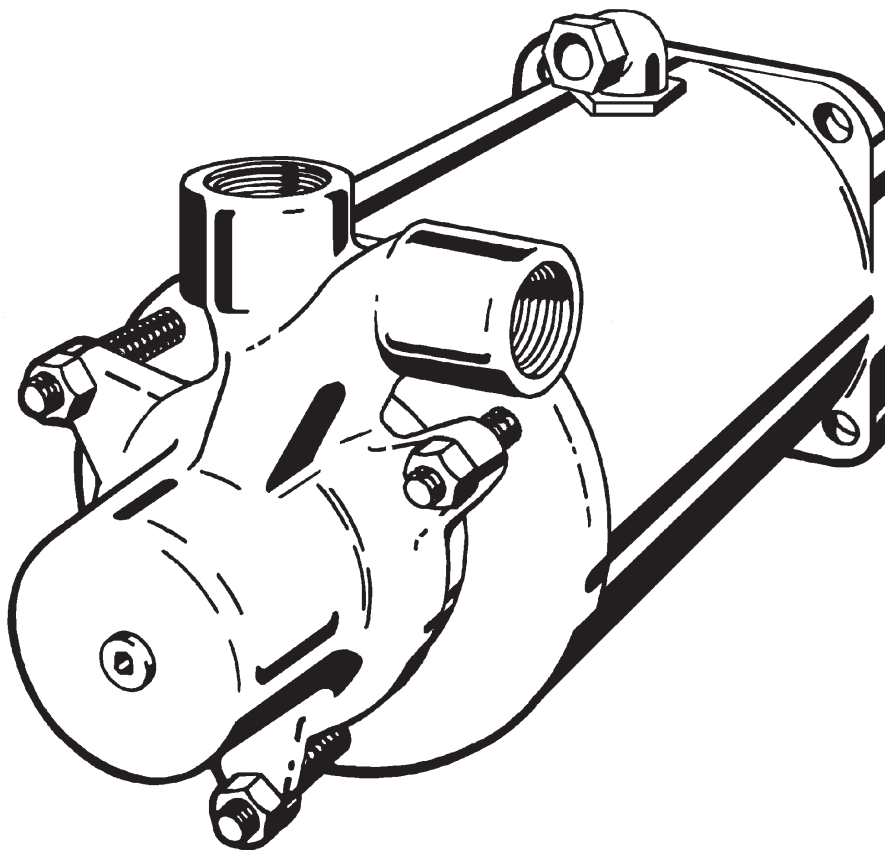

**MTH PUMPS**

401 West Main Street • Plano, IL 60545-1436  
Phone: 630-552-4115 • Fax: 630-552-3688  
Email: SALES@MTHPUMPS.COM  
<http://WWW.MTHPUMPS.COM>



**WARNING:**  
CANCER AND REPRODUCTIVE HARM  
[WWW.P65WARNINGS.CA.GOV](http://WWW.P65WARNINGS.CA.GOV)

## X SERIES

# 1. General Instructions

### CANNED MOTOR PUMPS

- A. Inspection of Equipment
- B. Storage
- C. Placing Stored Pumps Into Service
- D. Recommended Spare Parts

When properly installed and given reasonable care and maintenance, regenerative turbine canned motor pumps should operate satisfactorily for many years. Because of the high differential pressures expected in a regenerative turbine pump, close running clearances are used to reduce internal losses. Abrasive particles, even microscopic ones in high enough concentrations can open up the close clearances between internal cavities. For critical services it is recommended that you keep an identical pump for stand-by use.

#### 1A Inspection of Equipment

Immediately upon receipt of the shipment, inspect the equipment for damage or missing components. Check the shipping manifest and report any damage or shortage to the Transportation Company's local agent.

Put the instructions that came with the shipment in a safe place where they will be available to those who will be using them for installation and service.

#### 1B Storage

If the pump is to be stored before use, it should be inspected as described in 1A, crated and stored in a dry location. Standard shipping containers are not suitable for outdoor storage. In some areas, it may be necessary to cover the pump's exterior surface with oil or other rust inhibiting coating.

#### 1C Application Considerations

##### 1C1 Electrical Wiring

All electrical equipment and wiring should conform to Local and National Electrical Codes. Use the motor manufacturer's instructions

for connecting the motor. Note the correct rotation and wiring diagrams on the assembly. Make sure the motor rotation and speed matches that required for the pump.

##### 1C2 Construction Materials

While it is reasonable to assume that good judgement has been used in selecting all the materials in the pump for compatibility with process fluids, actual conditions sometimes vary from original expectations. Also, typical material selection charts do not consider all the temperature, pressure, and fluid variables. The customer's engineer should be consulted for final judgement on the best materials for critical process applications.

##### 1C3 Valves

The first valve to be considered for a regenerative turbine pumping system might be a pressure relief valve. Because this type of pump has a horsepower requirement similar to that of a positive displacement pump (constantly rising along with a pressure increase) a relief valve can be effectively used to limit horsepower. This is helpful when a non-overloading motor is specified. It can be of critical importance if the system flow rate can vary widely. There are almost no circumstances where a flow modulating valve will work successfully in a regenerative turbine pumping system. The steep pumping characteristic, typical of these pumps, produces very large pressure changes with small variations in flow rate. As a result, the modulating flow from the valve introduces sharp pressure shock waves that shorten pump life and may cause damage in other pieces of equipment in the system.

If a shutoff valve is necessary in the suction line, use a gate, ball, butterfly, or other full port valve. Globe or other flow restricting valves can in some cases reduce pump flow or increase chances of cavitation.

A swing check valve is recommended in the suction line even when the

pump inlet is only slightly higher than the fluid source. It should be the same size as the pump inlet or sized based on reasonable fluid friction losses.

A foot valve is recommended when lifting fluid from a sump. This will save wear and tear on any pump, even those equipped with self priming equipment.

A Y-Strainer is recommended immediately ahead of the pump on any newly constructed system. This is advisable due to the probability that foreign material large enough to damage pump clearances may remain even though the piping has been flushed.

Valves in the outlet piping of a regenerative turbine pump should always be open as far as possible when the pump is started. This will reduce the start-up load on the pump and motor. **Never start the pump with the discharge valve closed.**

Inlet valving should be open when starting any pumping system. Without some fluid in the pump, it can gall and lock up impellers. Always fill the pump and vent it of air for best pump life. **Violent pump failure will result from continued operation with the inlet valve closed.**

##### 1C4 NPSH (Net Positive Suction Head)

The NPSH required varies with every size and capacity of pump. The NPSH required by your unit can be obtained from the performance curves or from your MTH representative.

If the NPSH available is not equal to or greater than that required by



**WARNING:**  
CANCER AND REPRODUCTIVE HARM  
WWW.P65WARNINGS.CA.GOV

the pump, it must be increased or a different pump selected. The usual method for increasing NPSH is to raise the static head on the pump inlet, ( $H_s$ ).

By definition, NPSH means: "net positive suction head" above the vapor pressure of the pumped liquid available at the centerline of the pump. It should always be given in feet of pumped liquid. The NPSH is actually a measurement of the amount of energy available in the pumped liquid to produce the required absolute entrance velocity in the pump. If a pump requires more energy (or NPSH) than is available at a given capacity, the pressure at the inlet will fall below the vapor pressure of the pumped liquid and loss of performance will result.

$P_s$  = Pressure in the suction vessel in PSIA.

$P_{vp}$  = Vapor pressure of the pumped fluid in PSIA.

$H_s$  = Static height of the pumped fluid above (+) or below (-) the centerline of the pump.

$H_f$  = All friction losses from the vessel to the pump.

$$NPSH = 2.31 \left( \frac{P_s - P_{vp}}{\text{sp. gr.}} \right) + H_s - H_f$$

For boiling liquids,  $P_s$  and  $P_{vp}$  are equal. This item then becomes zero and can be omitted from the equation.

### 1C5 Noise

Regenerative turbine pumps typically produce a frequency sound that increases in intensity as the differential pressure produced in the pump increases. While high frequency sound is attenuated more easily than lower frequencies, piping structures and the fluids in them readily transmit noise. Motors, bearings, and other rotating components add to noise, which sometimes create objectionable harmonics.

Careful pump installation can contribute to noise reduction. Proper alignment of the pump and driver is essential. Adequate supports for the inlet and discharge piping is equally important. A degree of noise reduction may be obtained when the pumping unit is supported free of building structures by the use of vibration isolators, flexible piping and conduit connections. Elastomer type couplings are the best choice to separate motor noises from the fluid and piping structure.

### 1C6 Freezing

When ambient temperatures drop below the freezing point of the fluid in a pump, consideration should be given to heating, insulating, or draining the pump. If you choose draining the pump, and it will only be for a short period, first remove

the drain plugs and drain the lines to and from the pump. Carefully blow out the pump with compressed air to clear all internal cavities of fluid.

### 1D Recommended Spare Parts

FOR CRITICAL SERVICES - a duplex installation, with two identical pumping units in parallel, is the safest and many times the most cost effective choice.

FOR IMPORTANT SERVICES - a standby pump, ready for installation is advised.

Special pricing and new pump warranty is offered for factory rebuilding. Turn around time can be as short as one or two days for standard models.

### FOR ROUTINE MAINTENANCE

- only a complete set of "O" ring gaskets and bearings are recommended. Should additional components show wear, they are available from stock at the factory.

### FOR SERVICING A PUMP THAT DOES NOT PRODUCE RATED HEAD - "O" ring gaskets, impeller,

bearings, motor bracket, and cover.

## X SERIES

# 2. Installation

## CANNED MOTOR PUMPS

- A. Location
- B. Foundation
- C. Piping

In order to insure that pumping equipment is installed properly and to obtain reliable pump operation, it is recommended that only experienced, qualified erecting engineers undertake this task. Read the instructions thoroughly before beginning.

### 2A Location

The first consideration for locating a pump is elevation. The lowest possible elevation using the shortest possible suction piping is usually the best. Questions regarding possible locations should be resolved by making inlet head calculations including all friction losses. The one producing the highest inlet pressure should be selected. One reason for this precaution is that, the greater the inlet pressure, the less likelihood of NPSH problems. Also a flooded suction is particularly helpful on start-up when the pump can be ruined because it is not properly primed and purged of air.

A dry, easily accessible location is also important. Allow ample clearance around the unit for free air circulation. If a dry location is not available, the pump can be mounted on a foundation, above the floor. Specify motor enclosure, pump materials, or coatings to suit the worst conditions expected. Place the pump so that it can be easily inspected and serviced during operation. Sufficient head room should be provided, particularly when lifting devices will be used for heavier assemblies.

### 2B Foundation



WARNING:  
CANCER AND REPRODUCTIVE HARM  
WWW.P65WARNINGS.CA.GOV

Baseplates alone are not rigid enough to maintain alignment of the unit. The pump foundation is used as a support for the baseplate to maintain alignment of the unit. If the baseplate is to be grouted to the foundation, it is only necessary to embed the edges. It is unnecessary to completely fill under the baseplate. DO NOT grout the unit to the foundation until it has been properly aligned.

The foundation must be a permanent rigid installation of concrete or other material of sufficient mass to absorb all normal vibrations. Locate the foundation bolts using a layout or template in relation to the suction and discharge piping. If concrete is being used, foundation bolts of the specified size can be enclosed in a pipe sleeve two to three diameters larger than the bolts to compensate for minor variations in alignment.

Canned motor pumps can be mounted on a steel base prior to installation

or mounted directly to the foundation. Place shims under one or more of the motor feet so that strain and distortion will not result when the mounting bolts are tightened.

## 2C Piping

### 2C1 Piping Alignment

It is important that all piping be lined up and not forced into place. It is recommended that you begin piping at the pump. If the lines are ended at the pump, particularly if the last piece is cut a little too short or long, the pump will be forced to meet the pipe and strain or distortion will result.

### 2C2 Piping Support

Never allow the pump to support piping. Other means such as pipe hangers and pipe supports should be used to carry piping to avoid misalignment and distortion. Consideration should be given to thermally induced expansion and contraction, particularly in long runs of straight

pipe.

### 2C3 Piping Size

In general, inlet and outlet pipe sizes should be equal to or larger than those of the pump.

This should not, however, be the determining factor. Many things including installation and operating costs are involved in the decision. Careful use of the pipe and fitting friction loss tables as shown in the Hydraulic Institute manual along with the appropriate pump performance curve should be the basis for judgments.

## X SERIES

# 3. Operation

## CANNED MOTOR PUMPS

- A. Rotation
- B. Inlet and Outlet Locations
- C. Foreign Material
- D. Electrical
- E. Priming
- F. Starting
- G. Stopping

### 3A Rotation

The standard direction of rotation of the pump is clockwise when looking from the motor end. On canned motor pumps the pump shaft is not visible to check pump rotation. Always verify correct rotation by using a phase sequence indicator. If this is not possible, a final rotation check can be performed as follows.

1. Jog the motor briefly after venting the pump.
2. Observe the discharge gauge. No or limited pressure reading would indicate reverse rotation. Interchange any two motor leads and recheck rotation.

### 3B Inlet and Outlet Locations (Refer to Figure 3-1)

The standard mounting has the pump inlet located on the top of the pump casing. The discharge or "outlet" is on the side of the pump.

### 3C Foreign Material

All regenerative turbine pumps have close running clearances in order to maintain efficiency. Take extra precautions to insure that no foreign material larger than 25 microns or .001 inches is allowed to pass through the pump. Even particles of this size can damage the pump if allowed to continue. Regenerative turbine pumps are not designed for slurries.

Large particles, weld spatter, and other material found in new piping systems will bend the impeller vanes and can sometimes lock up the pump. If a new pump does not operate properly, the first thing to check for is damage from foreign material.

### 3D Electrical

It is important to be aware of and follow the appropriate local and national electrical codes. Do not make wiring alterations that can affect motor rotation without reconfirming correct rotation. Select starter heaters and wiring for the maximum current the motor can use at full service factor loads. Regenerative turbine pumps will typically use extra power for a period until they run in. This can take three to four weeks depending on the duty cycle. During this period, impellers are finding their hydraulically balanced position.

### 3E Priming

Pumps should not be operated unless they are completely filled with liquid. Damage to parts of the pump that depend on liquid for their lubrication can occur. Impellers can seize quickly when a pump is run dry.



**WARNING:**  
CANCER AND REPRODUCTIVE HARM  
WWW.P65WARNINGS.CA.GOV

Pumps can be easily primed with a vacuum pump. An ejector or liquid ring vacuum pump is recommended for this purpose because they are not damaged if liquid enters them.

Connect the vacuum line to the discharge side of the pump, either in the discharge opening or the drain tap. A foot valve is not necessary when this kind of device is used.

When a vacuum pump is not practical, a foot valve in the suction inlet can be used to prevent liquid from running out. The pump and suction line can then be filled completely from an outside source. A vent opening will be necessary during filling to let air escape. A tight foot valve will keep the pump constantly primed so that automatic operation is possible. The valve should be inspected regularly to see that it does not develop leaks which would allow the pump to run dry.

The best way to prime a pump and keep it primed is to use a flooded suction. While this is not always practical, it does provide a number of advantages. The likelihood of pump damage from dry running is eliminated. Suction lines may be large, reducing line losses and

minimizing the potential of cavitation damage. There are no check valves or priming devices to fail or require maintenance. Whenever possible, design pumping systems with flooded suction.

### 3F Starting

Before starting a pump for the first time, be sure that all the preceding operations have been carried out.

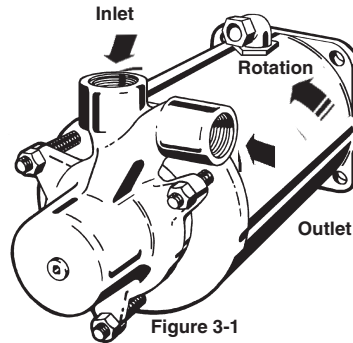

Proper rotation, priming, venting, and a free turning pump are most important.

1. Start the pump with the minimum possible line restriction.
2. Open discharge valves before pressing the starter.

3. Start the pump and let the system clear of air.
4. Listen for foreign material being carried through the pump.
5. Slowly close necessary valves or otherwise place the pump into service.
6. Listen for indications of undue load or other sounds indicating problems.
7. Use a clip-on ammeter to check for a steady load after approximately fifteen minutes of operation.

### 3G Stopping

It is best to stop the pump with the least discharge head possible both for minimizing strain on components and to be in low power mode in anticipation of restarting. If the pump will be down for more than a few weeks it is advisable to drain it. Follow the instructions for long term storage, Section 1, 1B Storage.

## X SERIES

# 4. Service

- A. Preliminary
- B. Disassembly
- C. Inspection of Components
- D. Reassembly
- E. Motor Bracket Setup Procedure
- F. Testing

### 4A Preliminary

Before attempting any service on the pump or motor, disconnect the electrical power to the pump motor. Note the wiring configuration, using colored or numbered tape to mark the wire connections of the motor and power source, for reconnection. If the pump is being used to pump hot liquid, let the pump and liquid cool before starting disassembly.

1. Disconnect the inlet and outlet piping before unbolting the pump/motor from its base. If the pipes are corroded, use penetrating oil on the threads to aid in removal.
2. Unbolt the pump/motor from its base and remove the unit from the system. All work on the unit should be performed on an elevated workbench whenever possible.

An exploded view of the unit, figure 4-9 is provided for referencing the numbers in the following procedures, i.e. (#84), motor bracket.

### 4B Disassembly

The following tools and equipment are needed for disassembly:

1. Soft plastic or wooden mallet.
2. 1/8" hex wrench
3. 3/16" hex wrench
4. 7/16" wrench or socket
5. 9/16" wrench
6. Two large blade screwdrivers
7. Side cutters

To disassemble the pump:

Refer to figure 4-9 for reference to the numbered parts in the procedures below.

1. Remove the two drain/vent plugs (#22), one located in the end of the pump body (#65) and the other on the end of the



**WARNING:**  
CANCER AND REPRODUCTIVE HARM  
WWW.P65WARNINGS.CA.GOV

X SERIES

# 4. Service

motor and drain all liquid from the pump and motor. Air blown through the pump will help remove the fluid quickly.

**NOTE:** There are two types of drain plug heads, which may be used in the pump, one requires a 7/16" wrench or socket, and the other requires a 1/8" hex wrench.

2. Remove the three nuts (#20) from the pump body (#65) using a 9/16" wrench.
3. Remove the pump body. Pull the pump body away from the motor bracket (#84). Light tapping with a plastic or wooden mallet on the pump body may be required to loosen the body from the motor bracket. Care should be taken if a pair of screwdrivers is needed to pry between the pump body and motor bracket. Damage to the O-ring (#7) and the machined surfaces of the body and motor bracket can result.
4. Using a 7/16" wrench or socket, remove the bearing retaining plug (#22A) from the pump body and slide the cartridge bearing (#16A) out for inspection. (Refer to 4-1)



Figure 4-1

5. Remove the impeller. The impeller is a slip fit and, under normal conditions, can be simply slid off the end of the shaft.
6. Remove the impeller key, using side cutters if necessary.
7. Remove the O-ring (#7) for inspection.
8. Remove the three jam nuts (#20A) and the other three nuts

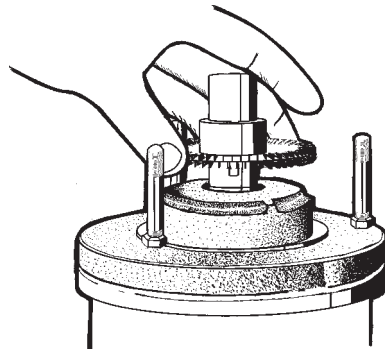

Figure 4-2

(#20) using a 9/16" wrench and slide off the motor bracket (#84). DO NOT loosen, tighten, or turn the three 3/8-24 setscrews (#15) in the motor bracket, refer to figure 4-9. These are used to set the motor bracket true with the shaft. If these are disturbed, it will be necessary to follow the "Motor Bracket Setup Procedure" when reassembling the pump, as outlined in section 4E Reassembly.

9. Slide the cartridge bearing (#16B) out of the motor bracket for inspection. (Refer to 4-3) The direction of the spiral groove in the bearing is extremely important, so keep the bearing with the motor bracket, as it can be easily confused with another bearing in the pump which has its groove cut in the opposite direction.

10. Remove the O-ring (#7A) for

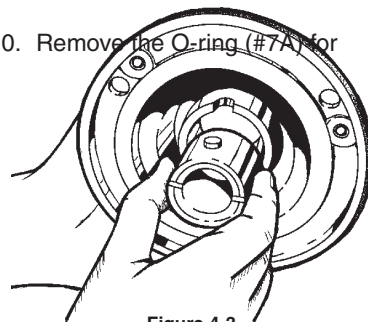

Figure 4-3

inspection.

11. Carefully slide the rotor out of the motor, and then remove the cartridge bearing (#16C) from inside the motor for inspection. Keep the bearing with the motor, as it can easily be confused with bearing (#16B), which goes in

the motor bracket described in step 9. (Refer to 4-4)

12. It is not necessary to remove

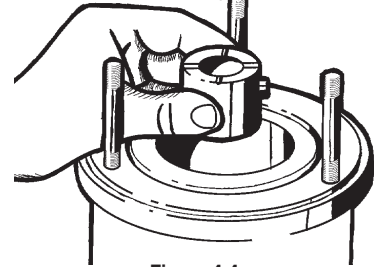

Figure 4-4

the three 3/8-16 studs (#5) in the motor unless the threads are damaged and require replacement.

### 4C Inspection of Components

Thoroughly clean all parts. All components should be examined for wear and corrosion. Replace any parts that show visible wear. If the pump was not producing sufficient pressure or capacity, the clearances between the pump housing and impeller probably exceed the maximum allowable clearance. At minimum the impellers should be replaced in this case. If the total side running clearance for an impeller exceeds .007", it is unlikely that pump performance will reach that of a new pump except at lower discharge pressures.

Replace any O-rings that have been deformed or cut.

Check the impeller, it is designed to float. It should move easily on the shaft. As long as it can be moved on the shaft by hand, it is loose enough. If the impeller can be rocked or wobbled, it is too loose and must be replaced.

Check the carbons in the cartridge bearings for wear. If the carbons show visible scoring or wear they should be replaced. Also, if the total clearance between the rotor shaft and the carbon exceeds .004" the bearings should be replaced.

Check the rotor for wear. If signs of wear or scoring are visible on the bearing surfaces, the rotor should



**WARNING:**  
 CANCER AND REPRODUCTIVE HARM  
 WWW.P65WARNINGS.CA.GOV

be replaced. If bearing surfaces are nicked or scratched, they should be polished, as good surface is imperative to long bearing life. Check the rotor liner for signs of wear. If bearings have worn far enough, the rotor may contact the stator and damage the liner. If the rotor liner has been worn open, the rotor should be replaced.

Check the stator liner for wear or damage. If the stator liner has been worn, dented, or otherwise damaged, the stator should be replaced.

#### 4D Reassembly

All parts should be visually inspected and cleaned or replaced as outlined in 4C above.

1. Place motor on end to begin assembling pump.
2. Install the cartridge bearing (#16C) into the motor with the face grooves facing up, refer to figure 4-4. Make certain the screw head slides into the groove in the bearing holder in the motor. Be careful not to install the cartridge bearing (#16B) which belongs in the motor bracket (#84). If you are uncertain which bearing goes where, refer to figure 4-5.

3. Slide the rotor into the motor,

Bearing No.	Location	No. of Face Grooves	Screw Head
16A	Pump Body (#65)	4	No
16B	Motor Bracket (#84)	2	Yes
16C	Stator (in Motor)	4	Yes

Figure 4-5

taking care not to drop it on or force it in the carbon bearing, as this will damage the bearing. Also be careful not to nick or scratch the bearing surfaces on the shaft.

4. Place O-ring (#7A) in groove on

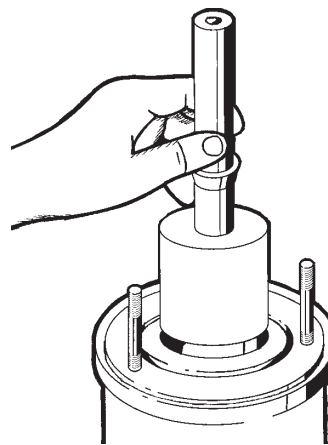

Figure 4-6

motor face.

5. Slide the cartridge bearing (#16B) over the shaft with the face grooves oriented down towards the motor. Refer to figure 4-7 & 4-9.
6. Install the motor bracket (#84)

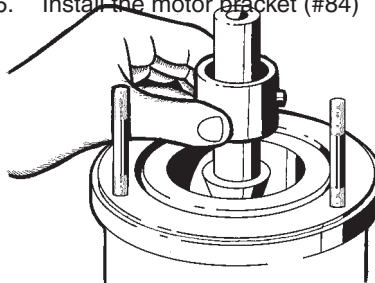

Figure 4-7

over the three studs (#5) so that the water stop is oriented on the same side as the motor conduit connection, refer to figure 4-9. Be certain to orient the cartridge bearing (#16B) on the shaft so that the screw head slides into its groove in the motor bracket, or the motor bracket will not slide completely onto the motor.

7. If the three 3/8-24 set screws (#15) have not been disturbed, install three nuts (#20) over the studs and evenly torque to 20 ft. lbs. and proceed to step 8. If the three 3/8-24 setscrews have been disturbed or the motor bracket is being replaced, do not tighten the nuts and proceed to 4E Motor Bracket Setup Procedure.

8. Install the O-ring (#7) over the

motor bracket. Refer to figure 4-9.

9. Thread the three jam nuts (#20A) over the studs, far enough so they will not interfere with the pump body when it is installed.
10. Place key (#23) in the shaft (#70A).
11. Install the impeller (#11). The impeller hub should be facing out away from the motor bracket. The impeller is a slip fit and should slide on firmly but easily until it stops against the impeller surface on the motor bracket. Force should not be required to install the impeller in the correct position.

12. Install the cartridge bearing (#16A) into the pump body (#65) with the face grooves to the inside, refer to figure 4-8. Rotate the bearing until the locking plug hole in the bearing holder is visible through the tapped hole in the pump body. Install the O-ring (#7B) onto the bearing locking plug (#22A), and then install the bearing locking plug into the locking plug hole. If the bearing has been installed backwards, the hole will not become visible and the retaining plug will not fit.

13. Lubricate both the O-ring on the

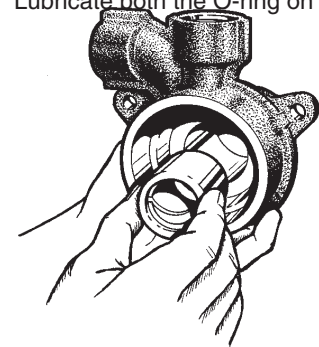

Figure 4-8

motor bracket and the o-ring groove in the pump body with a compatible lubricant.

14. Place the pump body over the three studs, aligning the water stop on the motor bracket with the water stop on the body. The pump inlet should be in line with the conduit connection on the motor, refer to figure 4-9. Some



**WARNING:**  
 CANCER AND REPRODUCTIVE HARM  
 WWW.P65WARNINGS.CA.GOV

X SERIES

# 4. Service

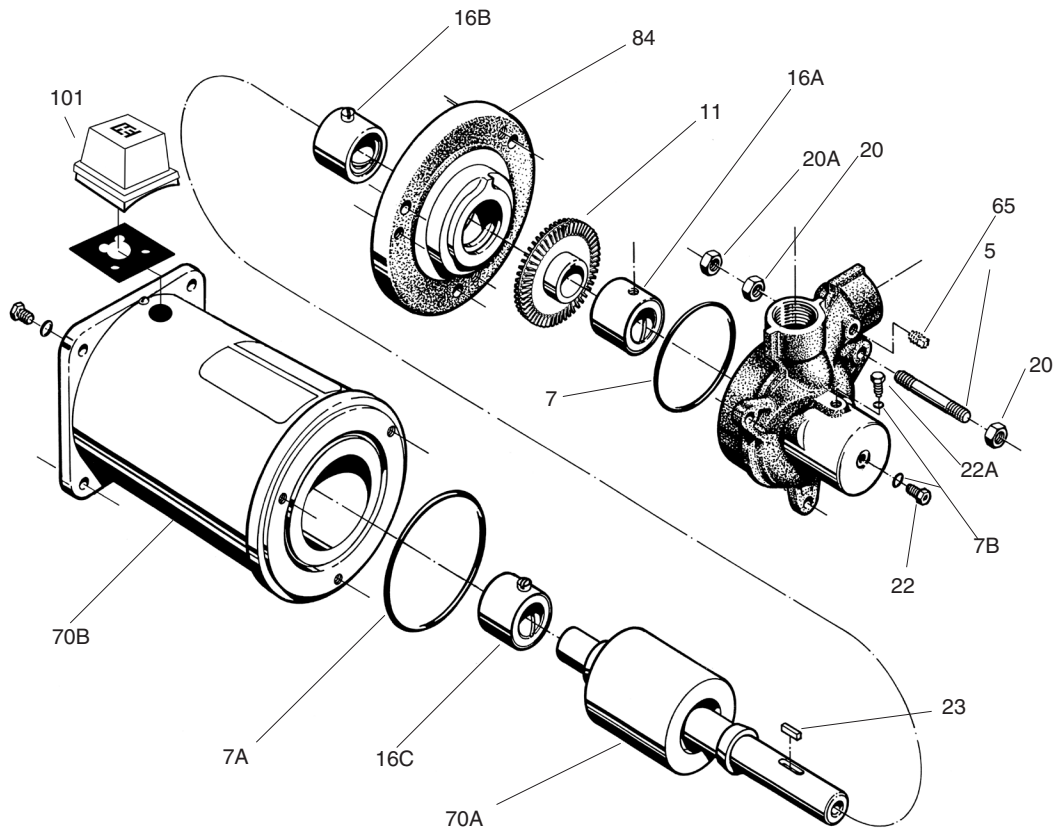

Figure 4-9

## X SERIES CANNED MOTOR PUMP

NAME/DESCRIPTION	PART NO.	QTY.
Stud	5	3
"O"Ring, Casing	7	1
"O"Ring, Motor	7A	1
"O"Ring, Plug	7B	3
Impeller	11	1
Adjustment Screws	15	3
Cartridge Bearing, Body	16A	1
Cartridge Bearing, L.H. Sprial	16B	1
Cartridge Bearing, R.H. Sprial	16C	4
Nut, Pump Body	20	6
Jam Nut	20A	3
Vent/Drain Plug	22	2
Plug, Bearing Locking	22A	1
Impeller Key	23	1
Endbell Screw	33	3
Conduit Elbow	40	1
Body	65	1
Shaft/Rotor Assembly	70A	1
Stator Assembly	70B	1
Motor Bracket	84	1
Endbell, Conduit End	101	1



**WARNING:**  
 CANCER AND REPRODUCTIVE HARM  
[WWW.P65WARNINGS.CA.GOV](http://WWW.P65WARNINGS.CA.GOV)

pressure may be required to push to pump body over the O-ring on the motor bracket. Be careful not to pinch and damage the O-ring.

15. Install the three remaining nuts and tighten evenly to 20 ft-lbs. Turn the jam nuts body.
16. Install the two drain/vent plugs, one in the end of the pump body, one in the back of the motor.

The pump is now ready for installation.

#### 4E Motor Bracket Setup Procedure

The following procedure is required when installing a new motor bracket or re-setting an existing motor bracket. This procedure is required to get the motor bracket true and perpendicular to the shaft.

1. Back out the three 3/8-24 set screws (#15) so that they do not contact the motor face.
2. Tighten the nuts (#20) to compress the o-ring between the motor face and the motor bracket.
3. Turn the three 3/8-24 setscrews so they just contact the motor face.
4. Install dial indicator tool over motor shaft so indicator tip will rest on the impeller face of the motor bracket and tighten the 3/8-16 nylon tipped setscrew against the motor shaft using a 3/16 hex wrench (do not over tighten). The indicator should be able to read .015" in either direction.
5. Zero Dial indicator. Rotate shaft

slowly, moving the indicator tip around the impeller face of the motor bracket. Take note of readings at the location of each of the three 3/8-24 setscrews.

6. Loosen the three nuts (#20). Compare your three readings from step "E". You will want to raise the lowest point(s) measured on the motor bracket equal to the highest point. To accomplish this, turn the 3/8-24 setscrew next to the low point(s) clockwise. This will normally only take a small fraction of a turn, as one complete turn will raise the motor bracket .042". Normally, you will only need to raise the motor bracket low point(s) a few thousandths of an inch.
7. Re-tighten the three nuts (#20) and check readings with indicator again as in step "E" above.
8. Repeat steps "E" thru "G" until the maximum difference between the three measured points is between .000" and .002". The closer to .000", the better.

#### 4E Testing

1. Reconnect the electrical connections referring to the colored or numbered tape used to mark the wires.
2. Connect all piping and fill the pump with fluid.
3. Make sure all valves are opened and fluid will flow through the system.
4. Loosen the drain/vent plugs, one

at a time, and retighten after all the air has escaped.

5. Jog the motor briefly after venting the pump.
6. Observe the discharge gauge. No or limited pressure reading would indicate reverse rotation. Interchange any two motor leads and recheck rotation.
7. Start the pump and check for leaks on the pump and piping.
8. Under pressure, the impeller will find its "hydraulic" balance.
9. Using an amprobe or similar device, check for motor overload.
10. While the impeller is seating it is common to experience some variance in readings. After a run-in period the readings should level off.

This completes the testing phase. The pump is now ready for service.



**WARNING:**  
CANCER AND REPRODUCTIVE HARM  
WWW.P65WARNINGS.CA.GOV

## X SERIES

# 5. Troubleshooting

### CANNED MOTOR PUMPS

- A. Failure to Pump
- B. Reduced Capacity
- C. Reduced Pressure
- D. Pump Loses Prime After Starting
- E. Excessive Power Consumption
- F. Pump Vibrates or is Noisy
- G. Mechanical Problems

#### 5A Failure to Pump

1. Pump not up to speed —  
Check voltage and wiring connections.
2. Pump not primed —  
Confirm that pump and all inlet piping is filled with fluid.
3. Discharge head too high —  
Install a pressure gauge at the pump discharge to determine the actual operating pressure. Compare readings with pump performance curve. A larger pump may be necessary.
4. Excessive suction lift —  
Relocate pump, supply tank, or both to minimize suction lift.
5. Wrong direction of rotation—  
Verify pump rotation with phase sequence indicator. Reverse two leads on a three phase motor to change rotation.
6. Clogged suction line, strainer, or foot valve —  
Inspect and clean out if necessary.
7. Air pocket in suction line —  
Look for high spots in inlet piping system. Evacuate the system with a vacuum pump if necessary.

#### 5B Reduced Capacity

1. Pump not up to speed —  
Check voltage and wiring connections.
2. Excessive suction lift —  
Relocate pump, supply tank, or both to minimize suction lift.

3. Insufficient NPSH —  
Relocate pump, supply tank, or both to improve NPSH available if possible. Increase suction pressure. Reduce fluid temperature. Select a pump with lower NPSH requirements.
4. Mechanical damage —  
Broken or bent impeller vanes may be the cause. If there is suspicion of damage, remove the pump from service and disassemble for inspection.
5. Air leak in the suction line —  
Fill the system with fluid and hydrostatically test. Tighten connections or replace leaky components.
6. Air pockets in the suction piping —  
Operating the system at maximum flow conditions will usually clear the lines. Evacuate the system with a vacuum pump if necessary.
7. Suction lines, strainer, or foot valve too small or clogged —  
Inspect and clean out as necessary. Fittings and lines should be at least equal to the pump suction size.
8. Discharge head too high —  
Install a pressure gauge at the pump discharge to determine the actual operating pressure. Compare readings with pump performance curve. A larger pump may be necessary.
9. Excessive wear —  
If a pump had previously performed satisfactorily and now gives evidence of reduced performance, it should be disassembled and examined for wear after the simpler possible problems have been pursued.

#### 5C Reduced Pressure

1. Pump not up to speed —  
Check voltage and wiring connections.
2. Air or vapor in liquid —  
Install a separator in the suction line. Hydrostatically test the system to insure that there are no leaks.
3. Mechanical wear or damage —  
Rotate the pump by hand to determine if there are tight spots. Broken or bent impeller vanes may be the cause. If there is suspicion of damage or wear, remove the pump from service and disassemble for inspection. Look for wear on the impeller, suction cover, and motor bracket.
4. System head less than expected —  
Replace pump with higher capacity unit or add a valve or orifice to increase line resistance.

#### 5D Pump Loses Prime After Starting

1. Leak in suction line —  
Fill the system with fluid and hydrostatically test. Tighten connections or replace leaky components.
2. Air entering pump through “O” rings —  
Hydrostatically test the pump looking for leaks. Replace faulty “O” rings.
3. Insufficient NPSH or too much suction lift —  
Relocate pump, supply tank, or both to improve inlet conditions. Increase suction pressure. Reduce fluid temperature. Select a pump with lower NPSH requirements.



**WARNING:**  
CANCER AND REPRODUCTIVE HARM  
WWW.P65WARNINGS.CA.GOV

### 5E Excessive Power Consumption

1. Speed too high —  
Check voltage and wiring connections.
2. Discharge head too high —  
Install a pressure gauge at the discharge to determine the actual operating pressure. Compare readings with pump performance curve. A different pump, motor or both may be necessary.
3. Specific gravity or viscosity too high —  
Check fluid involved. A different motor may be necessary.
4. Mechanical damage —  
If there is suspicion of damage, remove the pump from service and disassemble for inspection.
5. Pump not fully broken in —  
It is normal for new pumps to consume higher than normal current during the break-in period. If high power consumption persists beyond a few weeks, it is unlikely that further operation will reduce consumption.

### 5F Pump Vibrates or Is Noisy

1. Insecure mounting —  
Follow instructions in Section 2.
2. Piping load on pump —  
Install piping supports and check to see that there is no strain on the pump.
3. Mechanical damage —  
If mechanical damage is suspected disassemble for inspection.
4. Pump has a high pitched whine —  
This is typical of a regenerative turbine pump. The intensity should increase as pressure increases. Over a period of a few weeks the noise level will diminish and will be noticeably quieter as it approaches a run-in condition.

### 5G Mechanical Problems

1. Short bearing life —  
Bearings damaged due to foreign material. Piping load on pump. RPM or pressure too high.
2. Pump locked up —  
Pump dried out and close clearances rusty. Foreign material in pump. Flush out. Disassemble if flushing is not successful.
3. Pump leaks —  
“O” rings are usually the problem. Disassembly and replacement is the solution if tightening the bolts has no effect.

## X SERIES

# 6. Parts and Repair Services

- A. Parts
- B. Repair Service
- C. Warranty Service

### 6A Parts

Repair parts may be obtained through your local Authorized MTH Pumps Representative or Distributor who can be found in the yellow pages or by contacting:

MTH Pumps  
401 W. Main St.  
Plano, IL 60545  
Phone: 630-552-4115  
Fax: 630-552-3688.

### 6B Repair Services

Repair service for an MTH pump should be obtained from the company through which it was purchased.

In the event this is not possible, the name and phone number of a nearby MTH representative or distributor may be obtained by contacting MTH Pumps. In the event that it is necessary to return the pump to the factory for repairs, remove all accessories attached to the pump. We cannot accept responsibility for their safe removal, storage, and return.

### 6C Warranty Service

All requests for warranty claims should be made through the company from which the pump was purchased or supplied. Complete details on what is wrong with the pump must be provided along with information on the system in which it is installed. Refer to the MTH Pumps Limited Warranty statement. Return authorization must be obtained prior to returning any equipment.



**WARNING:**  
CANCER AND REPRODUCTIVE HARM  
WWW.P65WARNINGS.CA.GOV

X SERIES

# 7. Limited Warranty

MTH makes good faith recommendations of Products, based on its experience and the application information provided by the Purchaser. However, the responsibility for testing and approving a Product to be used for a particular purpose lies with the Purchaser.

The obligations of MTH Tool Company, Inc. (hereinafter referred to as "MTH"), with respect to a "Product" (defined below) are limited as set forth herein.

**ALL IMPLIED WARRANTIES, including the "implied warranty of merchantability" and the "implied warranty of fitness for a particular purpose" are HEREBY DISCLAIMED.**

***There are no warranties which extend beyond the description on the face hereof.***

MTH warrants that, during the "Warranty Period" (defined below), the "Product" (defined below) will not fail to meet the "Operational Specifications" (defined below), within applicable industry tolerances established by the Hydraulic Institute, due to defects in its materials and workmanship. MTH does not warrant that any Product will meet the "Operational Specifications" in conditions other than the Standard Operating Conditions, unless agreed to by MTH in a signed writing.

For all purposes of this Limited Warranty:

- (a) The term "Warranty Period" shall mean the twelve (12) month period from the date of shipment from MTH to the Purchaser (the "Warranty Period").
- (b) The term "Product" shall mean: any item or assembly of items sold by MTH that are either manufactured or selected by MTH to meet the "Operational Specifications". The term "Product" does not include any item, assembly of items, or portion of such assembly that is selected or specified by any entity other than MTH, or that MTH has identified as ineligible for warranty coverage.
- (c) The term "Purchaser" shall mean the original person(s) or entity that issued the purchase order to MTH, for the Product.
- (d) The term "Operational Specifications" shall mean the specified dimensions, material composition, and performance parameters of a Product, as published by MTH, or as otherwise agreed in a signed writing between MTH and Purchaser. "Standard Operating Conditions", for pumps, shall mean: operating with clean water, at standard temperature and pressure. "Operational Specifications" shall not include visual appearance or any other parameters not expressly agreed to in writing.

If, within the Warranty Period, a Purchaser believes that a Product has failed to meet its Operational Specifications, the Purchaser must request a Return Goods Authorization ("RGA") in the manner specified at <http://www.mthpumps.com>, and supply any additional information MTH might reasonably request. If the Product was purchased through a distributor or any entity other than MTH, the RGA request must be made through that entity. Any Product returned without an RGA will be refused at the dock. Products authorized for return must be properly packaged to prevent further damage, clearly marked with the Return Goods Authorization "RGA" number provided by MTH, and shipped freight prepaid and allowed, F.O.B. the MTH factory at Plano, Illinois, USA.

MTH may, in its sole discretion, deny any warranty claim if shipping damage, any attempted disassembly, or any other action outside of MTH's control impairs MTH's determination of the existence of, or cause of a claimed failure.

Notwithstanding anything to the contrary in this Limited Warranty, MTH **shall have no obligation** to repair or replace any Product it determines to have any defects arising from or attributable to: (1) abrasion, corrosion, or erosion arising after shipment from MTH; (2) improper handling, packaging, installation, storage, or maintenance, after it is shipped by MTH; (3) repairs or alterations outside of MTH's factory, in any manner, without MTH's written authorization; (4) misuse, negligence, or accident after shipment from MTH; (5) use in a manner inconsistent with MTH's published instructions and Operational Specifications, or other written specifications agreed to by both Purchaser and MTH; or (6) incorrect power supply or power quality. MTH's determination with respect to the applicability of this Limited Warranty to any particular defect or Product shall be final and conclusive.

If, after examination by an authorized representative of MTH, MTH determines that the Product failed to meet the "Operational Specifications", within applicable industry tolerances established by the Hydraulic Institute, due to defects in its materials and workmanship, during the Warranty Period, then MTH will, at its option, ship a repaired or replaced Product to the Purchaser, F.O.B. MTH's factory in Plano, Illinois, U.S.A., freight prepaid and allowed. MTH will use a freight provider of its choosing, via a method no faster than that used for shipping the Product to MTH. MTH may, at its sole discretion, issue a credit memo to Purchaser for some or all Purchaser's shipping costs to return a defective Product to MTH.

MTH accepts no responsibility for costs associated with removal and reinstallation of Products.  
**Under no circumstances shall MTH be liable for incidental or consequential damages.**

MTH neither assumes responsibility for, nor authorizes any person to assume for it, any other obligation in connection with the sale of any Product or any enlargement of this Limited Warranty.

**Some States do not allow the exclusion or limitation of incidental or consequential damages. So, the above limitations or exclusions might not apply to you. This warranty gives you specific legal rights, and you might, also, have other rights, which vary from State to State.**

**By using this Product, you agree that this Limited Warranty is governed by the laws of the State of Illinois; that this Limited Warranty shall be interpreted and enforced only in accordance with the laws of the State of Illinois (excluding its conflicts of law provisions); and that you submit yourself to the jurisdiction of the 23rd Judicial Circuit, Kendall County, Illinois, which shall have exclusive jurisdiction over any controversy or dispute arising under or with regard to this Limited Warranty.**



**MTH PUMPS**

401 West Main Street • Plano, IL 60545-1436  
Phone: 630-552-4115 • Fax: 630-552-3688  
Email: SALES@MTHPUMPS.COM  
<http://WWW.MTHPUMPS.COM>



**WARNING:**  
CANCER AND REPRODUCTIVE HARM  
[WWW.P65WARNINGS.CA.GOV](http://WWW.P65WARNINGS.CA.GOV)

Order Online: [www.PumpCatalog.com](http://www.PumpCatalog.com)