

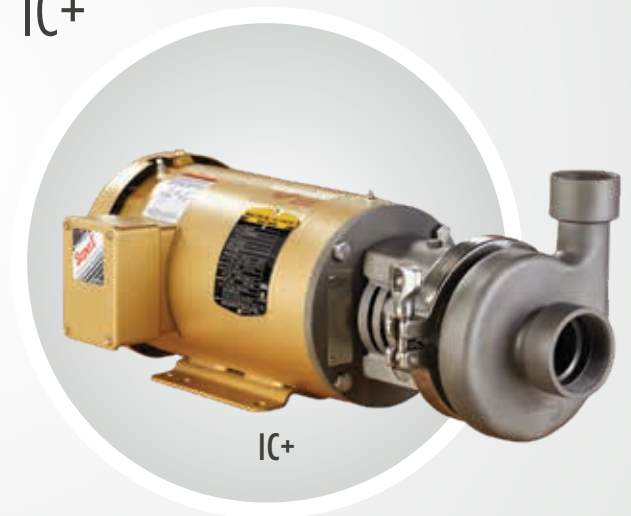

AMPCO'S COMPLETE LINE OF AC SERIES PUMPS

AC / AC+ / IC+



AC / AC+ pumps are in compliance with 3A Standards and offer these additional advantages:

- Low Cost • AC parts are 100% interchangeable with other brands
- 316L Stainless steel construction • Stainless steel adapters are standard • One week delivery



AC+ SERIES SANITARY

AC+ pumps are the first significant improvement in the traditional "C Series" style of pumps in over a quarter century. These pumps offer an improved shaft design comparable to more expensive sanitary pumps, while retaining the hydraulic characteristics and external dimensions of the AC product line.

- Clamped stub shaft and threaded impeller nut provide more stable performance
- External dimensions are the same as AC pumps – no need to change piping
- Hydraulic performance is identical to the AC pumps
- Casing, backplate, adapter and seals are interchangeable
- Standard one week delivery



AC SERIES SANITARY

AC pumps are in compliance with 3A standards and offer these additional advantages:

- Low cost
- AC parts are 100% interchangeable with other leading brands
- 316L Stainless steel construction
- Stainless steel adapters are standard
- Optional NPT, flanged and standard international connections available
- Standard one week delivery

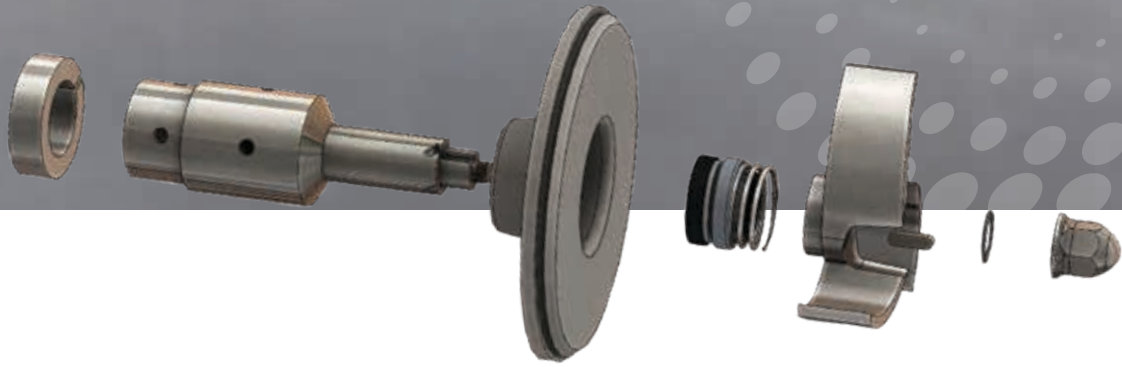

IC+ SERIES INDUSTRIAL

IC+ pumps are based on the AC+ design, but intended for non-sanitary applications.

- Pumps are constructed of 316L stainless steel
- Glass beaded finish with standard NPT connections and flanges optional
- Type 21 mechanical seal with multiple material options
- External dimensions are the same as the AC / AC+ pumps
- Hydraulic performance is identical to AC / AC+ pumps
- Every IC+ pump includes a standard stainless adapter
- Standard one week delivery



BEARING FRAME

AC+ / AC / IC+

- Dual deep groove ball bearings
- Cast iron bearing frame
- D, DG, E, and Type 21 seals



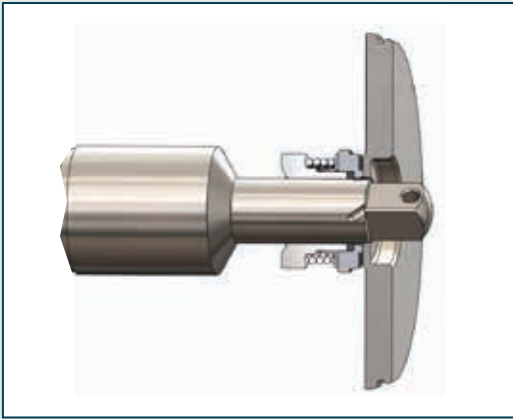

TYPE D EXTERNAL BALANCED SEAL

Well-suited for multi-purpose use, this seal is designed to give long service life. Typical applications include:

- Dairy products
- Tomatoes
- Beverages

Also applicable for acid cleaning solutions and detergents.

Seal materials: External balanced seal.
Carbon/Stainless Steel

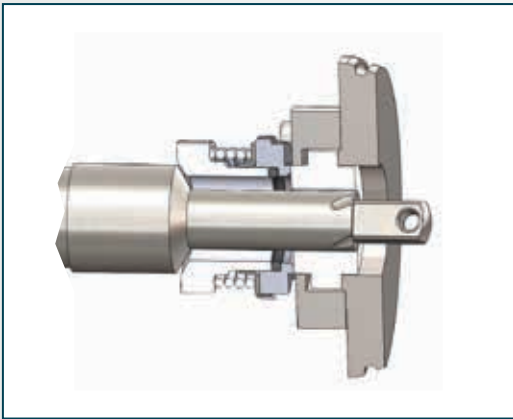

TYPE DG SEAL/SEAT

This long lasting seal assembly utilizes standard Type D rotating seal components plus choice of silicon carbide, ceramic or tungsten carbide stationary seal seat. For maximum corrosion resistance in pure water applications with abrasive or non-lubricating products. Stationary seat is reversible for quick changeover if one side is damaged. The standard seal material is silicon carbide

Seal materials: External balanced seal with replaceable stationary seat. Carbon/Silicon Carbide, Carbon/Ceramic, Carbon/Tungsten Carbide.

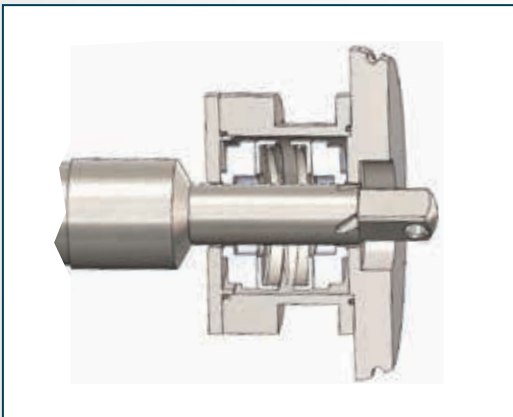

TYPE E WATER COOLED BALANCED DOUBLE SEAL

This water cooled balanced double seal can be pressurized to contain coolants or sealants which can be piped directly to drain. It is used in slurries, heavy duty vacuum applications (to 28" Hg), tacky products or products at temperatures up to 212°F.

Seal materials: Water cooled balanced double seal.
Carbon/Stainless Steel

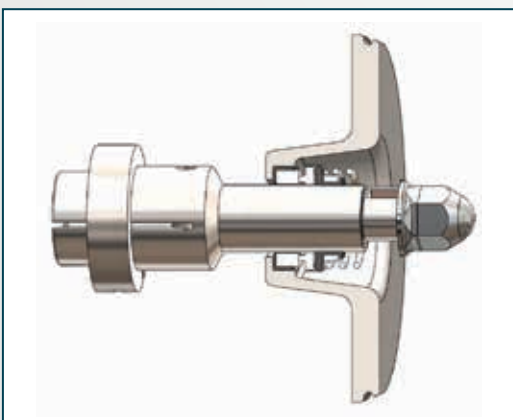

JOHN CRANE TYPE 21 INDUSTRIAL SEAL

- Single internal mechanical seal assembly
- Standard combination is ceramic versus carbon seal faces with buna elastomer, other combinations are available
- CIP supply and return for non-3-A or USDA applications

AMPCO MODELS AC / AC+ / IC+	COMPETITOR MODEL	INLET	OUTLET	MAXIMUM IMPELLER
AC/AC+/IC+ 114	C114	1.5"	1.5"	4"
AC/AC+/IC+ 214	C214	2.0"	1.5"	4"
AC/AC+/IC+ 216	C216	2.0"	1.5"	6"
AC/AC+/IC+ 218	C218	2.0"	1.5"	8"
AC/AC+/IC+ 316	C316	2.5"	1.5"	6"
AC/AC+/IC+ 318	C318	3.0"	1.5"	8"
AC/AC+/IC+ 328	C328	3.0"	2.0"	8"
AC/AC+/IC+ 428	C428	4.0"	2.0"	8"
AC+/IC+ 4410	Not available	4.0"	4.0"	10"
AC+/IC+ 6410	Not available	6.0"	4.0"	10"

Construction Materials: All models are made of 316L stainless steel

AMPCO PUMPS COMPANY AC-SERIES COMPOSITE CURVE

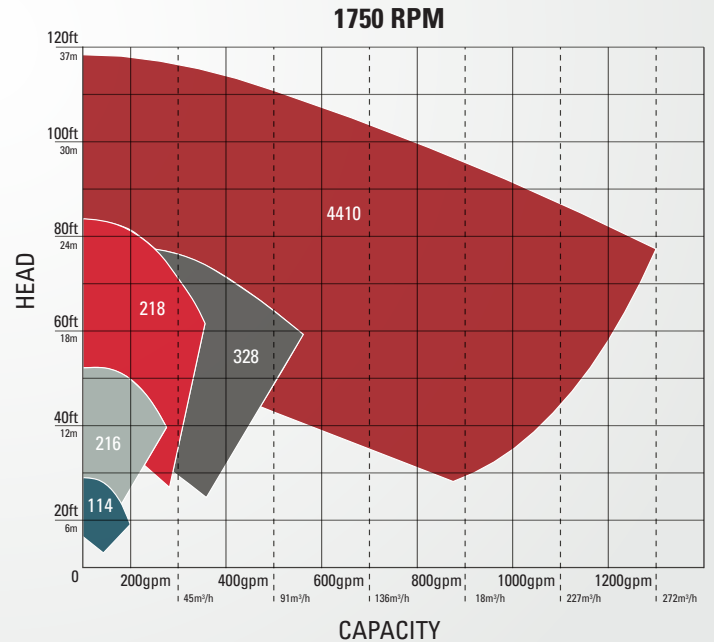
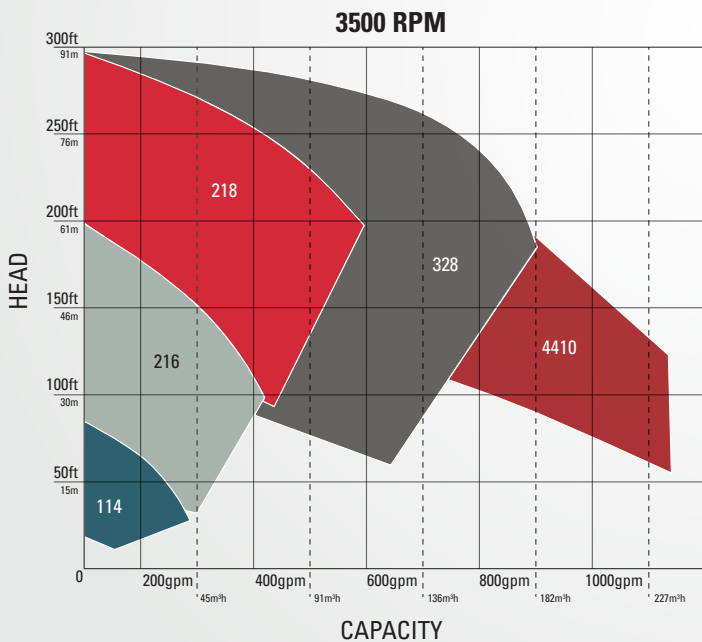

Motors: Offered in NEMA 56C, TC, TSC and IEC



COMMON APPLICATIONS

AC / AC+

Bottled water
Brewing
Poultry Industry
Marinade Solutions
Red Water Chillers
Carbonated Beverages
Juice
Dairy
Pharmaceutical

IC+

Hot Water
Cold Water
Light Chemicals
Water with Particles

Order Online: www.PumpCatalog.com

Headquarters

2045 W. Mill Road
Glendale, WI 53209 / USA
Tel: 414.643.1852
Fax: 414.643.4452
info@ampcopumps.com



[Ampco Pumps GmbH](http://www.AmpcoPumps.com)
Gewerbepark West II 7
76863 Herxheim Germany
Phone: +49 7276 5058515
info@ampcopumps.de

Please visit www.ampcopumps.com
for individual pump curves and dimensional drawings.