

Please read and save this Repair Parts Manual. Read this manual and the General Operating Instructions carefully before attempting to assemble, install, operate or maintain the product described. Protect yourself and others by observing all safety information. The Safety Instructions are contained in the General Operating Instructions. Failure to comply with the safety instructions accompanying this product could result in personal injury and/or property damage! Retain instructions for future reference. AMT reserves the right to discontinue any model or change specifications at any time without incurring any obligation.
©2014 American Machine & Tool Co., Inc. of PA, A Subsidiary of The Gorman-Rupp Company, All Rights Reserved.

Periodic maintenance and inspection is required on all pumps to insure proper operation. Unit must be clear of debris and sediment. Inspect for leaks and loose bolts. Failure to do so voids warranty.

Multistage Centrifugal Pumps

Vertical Inline Models



Refer to pump manual 1808-634-00 for General Operating and Safety Instructions.

DESCRIPTION

APPLICATIONS

These commercial/industrial centrifugal pumps are non-self-priming (gravity feed) units designed to handle high-pressure/low-flow liquid transfer applications where no suction lift is required. Typical installations include hot and chilled water, boiler feed, condensate return, irrigation, high pressure wash-down, booster service, and sprinkler systems. These pumps have NOT been investigated for use in potable (drinking) water systems.

FEATURES

The in-line port design and compact footprint of these pumps allows for a clean installation. All models feature a shaft seal that can be replaced easily without the need to disassemble the entire pump. An optional ANSI/ASME flange kit is available. Pumps are equipped with high efficiency closed impellers, and have a casing working pressure to 536 ft./232 psi [1600 kPa]. Handle liquid temperatures from 40° F to 180° F [4° to 82° C]. For use with clear, nonabrasive, nonflammable liquids compatible with pump component materials.

MOTOR

All models have 3450 RPM (2850 RPM for 50 Hz) continuous duty TEFC motors. Single phase units are capacitor start and have automatic reset thermal protection. All models are manual mode and require field wiring, no controls are supplied.

▲ CAUTION

Motors have multi-voltage options. To avoid damage to motor, be sure to arrange internal motor wiring to match electric supply voltage before applying power (see motor nameplate for specific wiring diagram).

PUMP CONSTRUCTION

Pump construction is cast iron casing and adapter; 304 stainless steel impellers, chambers and column; Teflon® wear rings; 304L stainless steel pump shaft with tungsten carbide sleeve bearings; EPDM o-rings and gaskets; a mechanical shaft seal of stainless steel, carbon graphite, and tungsten carbide wear faces.

▲ WARNING

All units are for use with non-flammable, non-abrasive liquids compatible with pump component materials.

IMPORTANT: Not for use with petroleum based liquids.

INSTALLATION

MOUNTING

Preferred mounting position is with motor shaft aligned vertically.
(See Figure 1)

1. Choose a solid, level surface with adequate support such as a concrete slab floor.
2. Use a level against pump to check for plumb. For uneven surfaces, shim beneath feet of Casing (Ref. No. 38) to attain proper alignment.
3. Securely fasten Casing to mount surface at all four mount holes to avoid tip-over of pump. If space limitations dictate, pump may also be mounted horizontally if adequate support is provided. Do NOT mount motor end down or with shaft centerline below horizontal plane.

PIPING

Pump may have a protective cover over inlet and outlet for shipping purposes. If present, be sure to remove these covers prior to attaching piping. If flange

Screws (Ref. No. 41) are loosened, be sure to re-tighten evenly and torque to 33 ft-lbs [45 N-m] to avoid Gasket (Ref. No. 39) failure.

Starving the pump of liquid could cause low performance and damage to pump and seal. To avoid this, use suction piping that is short and either matches pump port diameter or is larger, do not reduce. Also, immediately preceding pump inlet, provide a section of straight pipe equal in length to a minimum 4 diameters of pipe size and avoid using valves.

These pumps develop very high pressures. Be sure to confirm that pressure rating of all piping and fittings is adequately sized before use. Rating must be sufficiently larger than the combination of both inlet pressure plus the maximum pressure pump can develop.

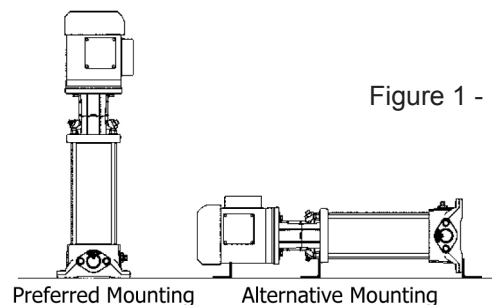

Figure 1 - Mounting

Multistage Centrifugal Pumps

▲ WARNING

Piping and/or pipe fittings with an insufficient pressure rating may burst and cause personal injury and/or property damage.

MAXIMUM INLET PRESSURE

“1” Series

2 to 25	335 ft./145 psi [1000 kPa]
27 stage	500 ft./217 psi [1500 kPa]

“3” Series

2 to 15	335 ft./145 psi [1000 kPa]
17 to 25	500 ft./217 psi [1500 kPa]

“5” Series

2 to 9	335 ft./145 psi [1000 kPa]
10 to 29	500 ft./217 psi [1500 kPa]

If system pressure has potential to exceed number listed above, then a check valve is required on discharge side of pump. This will ensure that proper inlet pressure is maintained when pump shuts off.

MAXIMUM OUTLET PRESSURE

If system pressure in excess of 536 ft./232 psi [1600 kPa] is possible, then it is necessary to provide means to prevent this. Examples include a bypass valve or pressure switch on discharge of pump set at or below this number.

OPERATION

Become familiar with pump components (See Figure 2).

Vent Plug (Ref. No. 13) – Used to purge air from pump.

Wash Plug (Ref. No. 11) – Used in applications where seal wash is desired to extend life of shaft seal.

Bypass Valve (Ref. No. 42) – Connects suction and discharge sides of pump, making filling/draining procedure easier. During operation, bypass valve must be closed.

▲ CAUTION

Never run pump dry or with flow shutoff. When pump is running, always maintain a minimum flow of 4 gpm [0.9 m3/h] to avoid damage to pump.

STARTUP PROCEDURE

▲ CAUTION

To avoid pump damage, it is very important to purge all air from pump before initial startup.

1. Close discharge valve if present.
2. Permit liquid to flow into pump thru suction port by gravity.
3. Allow air to escape from pump by cracking open Vent Plug (Ref. No. 13) in top of pump housing near motor.
4. Wait for liquid to cease sputtering. When liquid flow changes to a steady stream with no air, close Vent Plug.

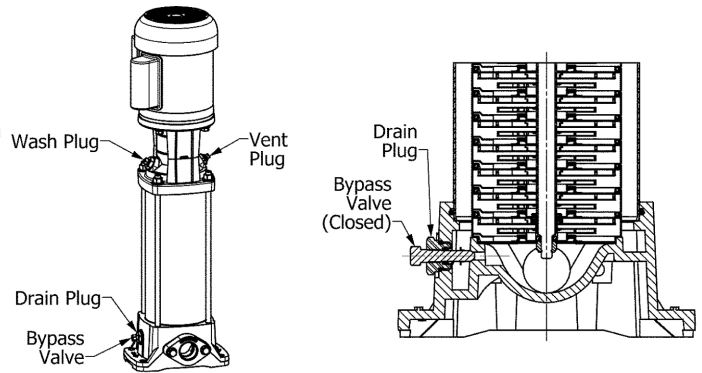

Figure 2 - Components

5. Run pump briefly, then repeat steps 1 thru 4 repeatedly until all air is evacuated. Pump is now ready to be run.

ROTATION

Proper rotation is CLOCKWISE when looking up at shaft end of motor, see directional arrow cast into motor Adapter (Ref. No. 8). Bump motor on/off briefly to confirm motor is wired for correct rotation. Disregard rotation information found elsewhere in safety manual.

DRAINING

1. Remove Bypass Valve (Ref. No. 42) and Vent Plug (Ref. No. 13) completely.
2. Allow liquid to drain.
3. If pump is to be subjected to freezing temperatures, do not reinstall Valve/Plug.

CYCLING

Frequent on/off cycling can shorten motor life. System should be designed so that pump is NOT starting more than 15 times per hour.

MAINTENANCE

▲ WARNING

Make certain that unit is disconnected from power source before attempting to service or remove any components!

MOTOR REPLACEMENT

DISASSEMBLY

Refer to Figure 7

1. Remove two coupling Shields (Ref. No. 9) by unscrewing two Fasteners (Ref. No. 10) for each.
2. Loosen four Fasteners (Ref. No. 4) in Coupling (Ref. No. 3) evenly until Motor shaft (Ref. No. 1) can turn independently from Coupling.
3. Remove four Fasteners (Ref. No. 14) from Adapter (Ref. No 8). Motor is now free, lift straight up to remove from unit.

REASSEMBLY

1. Remove key (if present) from new Motor shaft and discard.
2. Wipe any protective film from Motor end bell and shaft, be sure they are

Multistage Centrifugal Pumps

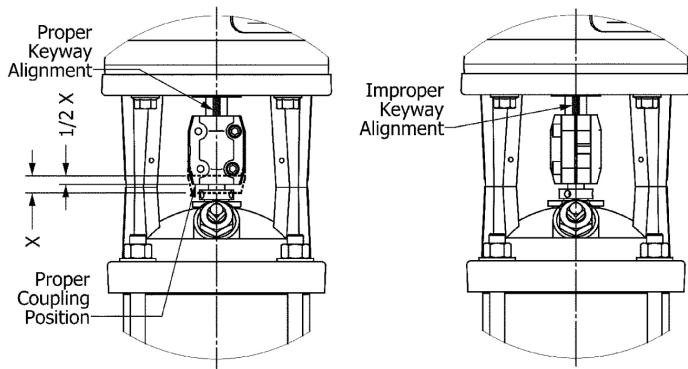

Figure 3 - Coupling Alignment

clean.

3. Carefully guide Motor shaft into Coupling while setting new Motor into place.
4. Reinstall four Fasteners thru Adapter. Tighten evenly and in diagonal pattern, then torque to the following specifications:

3/8.....	17 ft-lbs. [23 N-m]
1/2.....	30 ft-lbs. [41 N-m]
5. Locate shaft keyway in center of Coupling (See Figure 3) and maintain this position, then snug up Fasteners evenly. Check gap between coupling halves to be sure it remains even on both sides. Torque Fasteners to the following specifications.

M6	10 ft-lbs. [14 N-m]
M8	23 ft-lbs. [31 N-m]
M10.....	46 ft-lbs. [62 N-m]
6. Rotate pump Shaft by hand. If binding or rubbing is found, loosen Coupling and readjust position.
7. Reattach Shields and proceed to Startup Procedure section.

SHAFT SEAL REPLACEMENT

DISASSEMBLY

Refer to Figure 7.

1. Remove Motor (see Motor Replacement section).
2. Remove Coupling (Ref. No. 3) and Rod (Ref. No. 2) by unthreading Screws (Ref. No. 4).
3. Loosen, but do not remove set screws in Shaft Seal Assembly (Ref. No. 7).
4. Unscrew Shaft Seal Assembly in a counter-clockwise direction, then carefully lift off of Shaft (Ref. No. 21).

REASSEMBLY

IMPORTANT: Pump Shaft may have been gouged from set screws. Before installing new Shaft Seal Assembly, smooth-over these gouges with a light grit emery cloth to prevent damage to new seal.

1. Once shaft is free of burrs, lubricate Shaft and o-ring cavity in Adapter (Ref. No. 8) with soapy water.
2. Carefully slide new Shaft Seal Assembly onto Shaft, then tighten in clockwise direction and torque to 26 ft-lbs [35 N-m].

3. Mark or otherwise note shaft height. Lift shaft as high as it will go, then lower it back down 1/2 the total distance. Maintain this position while evenly tightening 3 set screws in seal collar and torque each to 2 ft-lbs. [2.5 N-m].
4. Place Rod thru Shaft, then reinstall Coupling and screws but do NOT tighten.
5. Proceed to Reassembly under Motor Replacement section.

PUMP OVERHAUL/INSPECTION

To inspect condition of pump internals, proceed as follows:

NOTE: To facilitate overhaul, a handy holding device can be made easily. Take a short piece of 2x4 lumber and on the narrow side, drill a 1/2" diameter blind hole 3" deep. Place block into bench vice with hole facing up to receive pump shaft after step 5 (see Figure 4).

DISASSEMBLY

1. Proceed to Disassembly under Shaft Seal Replacement.
2. Remove 4 Fastener sets (Ref. Nos. 15 & 16).
3. Lift Adapter (Ref. No. 8) from pump, use a soft mallet to break loose if necessary. **NOTE:** Inspect o-ring groove in Adapter after o-ring is removed. Rust/pitting in this region may cause leaks, be sure to clean or replace Adapter entirely if damage is excessive.
4. Remove wave Spring (Ref. No. 18) from Adapter. **NOTE:** Inspect wave Spring for cracks and replace if found.
5. Pump internals can now be removed all at once. Use pump Shaft (Ref. No. 21) as a handle and gently lift the entire assembly out. If stage-1 Volute (Ref. No. 38) stays behind, it can be removed and inspected later. **IMPORTANT:** Stainless steel components deform easily, be careful to avoid damaging pump components during disassembly.
6. Unscrew Hex Nut (Ref. No. 37) from pump Shaft in a counter-clockwise direction and remove along with Sleeve Cup (Ref. No. 35).
7. Lift Volute (if still present) and Impeller (Ref. No. 26) from stack and set aside.

IMPORTANT: Take note of sequence parts are arranged in and direction they are facing, number and mark if necessary (see Figure 6 & 7).

8. Lift next Volute/Crossover (Ref. No. 34), Inner Bearing (Ref. No. 32), and

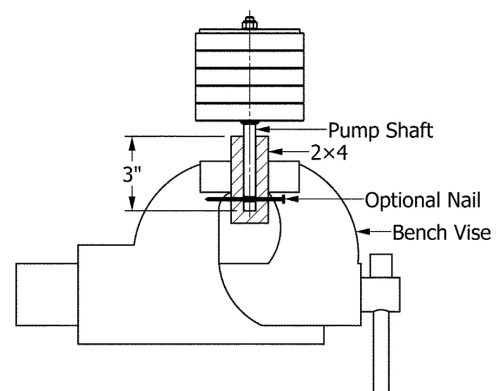

Figure 4 - Inspection

Multistage Centrifugal Pumps

Impeller from stack.

NOTE: Inspect Inner and Outer Bearings for wear. If grooves can be seen or felt, replace both bearings as a set.

9. Use a large straight blade screwdriver to carefully pry Cap (Ref. No. 28) from Crossover to free Wear Ring (Ref. No. 29).

NOTE: Inspect for wear by placing Wear Ring over nose of Impeller and noting clearance between two diameters. If fit is not snug, replace Wear Ring.

10. Repeat Steps 7 and 8 for each stage (some stages have no bearings)

NOTE: Inspect Shaft (Ref. No. 21) for grooves, replace if splines are worn.

11. Lift Cylinder (Ref. No. 20) from Casing (Ref. No. 39), use a soft mallet to break loose if necessary.

NOTE: Inspect o-ring groove in Casing after o-ring is removed. Rust/pitting in this region may cause leaks, be sure to clean or replace Casing entirely if damage is excessive.

12. If stage-1 Volute (Ref. No. 38) remains in Casing, now is the time to remove it. Gently pry loose with a straight blade screwdriver, being careful to avoid bending it.
13. Unscrew 2 fasteners (Ref. No. 42).
14. Use a straight blade screwdriver to pry pipe Flange (Ref. No. 41) loose.
15. Use a putty knife to scrape off old Gasket (Ref. No. 40) from Flange and Casing.

REASSEMBLY

1. Always use new Gaskets (Ref. No. 40) when reassembling. Attach pipe Flanges (Ref. No. 41) with Fasteners (Ref. No. 42). Tighten evenly and torque to 33 ft-lbs [45 N-m].
 2. Place new O-ring (Ref. No. 19) into cleaned groove of Casing (Ref. No. 39), be sure to lubricate with soapy water or suitable material.
 3. Place stage-1 Volute (Ref. No. 38) back into Casing (Ref. No. 39) making sure it is seated properly.
 4. Carefully guide Cylinder (Ref. No. 20) back into Casing and press down.
- IMPORTANT:** If Cylinder does not fully seat, O-ring may be pinched. If this occurs, lift Cylinder back out and try stretching O-ring. Be sure components are adequately lubricated and have not been damaged. Repeat process until end of Cylinder bottoms on Casing.

5. Reassemble Impellers (Ref. No. 26), Crossovers (Ref. No. 34), etc. onto pump Shaft (Ref. No. 21) in same order they were removed (see Figure 6 & 7) and torque Hex Nut w/Nyloc (Ref. No. 37) to 13 ft-lbs [18 N-m]

IMPORTANT: NEVER reuse Hex Nut w/Nyloc, ALWAYS replace with new unused one.

6. Take Impeller/Crossover stack by Shaft and lower into pump until properly seated.
7. Place new O-ring (Ref. No. 19) into cleaned groove of Adapter (Ref. No. 8), be sure to lubricate with soapy water or suitable material.
8. Install wave Spring (Ref. No. 18) with ends pointed towards Adapter. With wave Spring seated on proper landing in Adapter, carefully guide Adapter onto pump and press down.

IMPORTANT: If Adapter does not fully seat, O-ring may be pinched. If this occurs, lift Cylinder back out and try stretching O-ring. Be sure components are adequately lubricated and have not been damaged. Repeat process until Adapter bottoms on end of Cylinder.

9. Reinstall Fasteners (Ref. Nos. 15 & 16) onto Staybolts (Ref. No. 17) and tighten diagonally.
10. Proceed to Reassembly portion of Shaft Seal Replacement.

Multistage Centrifugal Pumps

For Repair Parts contact dealer where pump was purchased.

Please provide following information:

-Model Number

-Serial Number (if any)

Part description and number as shown in parts list

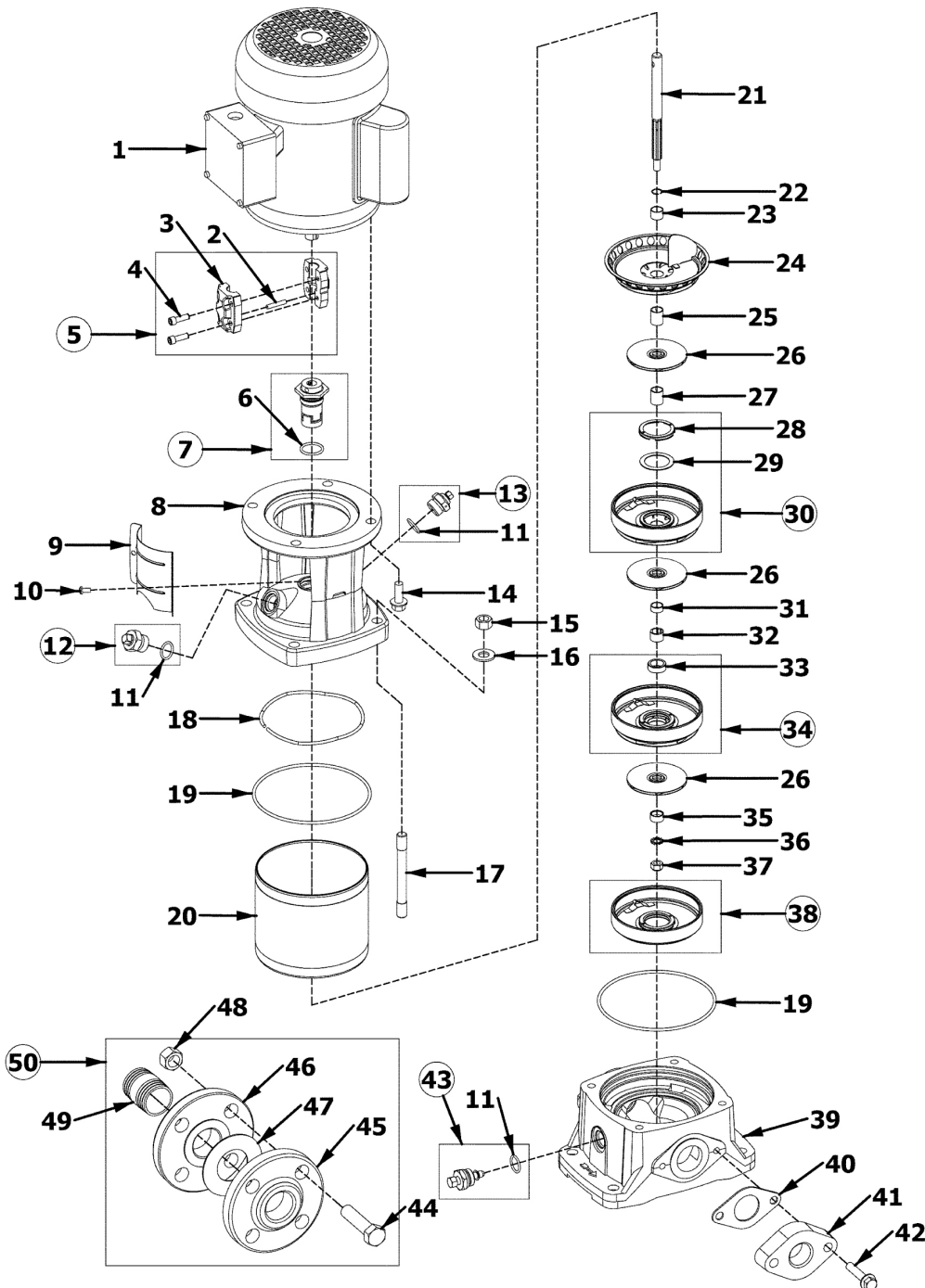

Figure 7 - Repair Parts Illustrations

Repair Parts List

Ref. No.	Description	Part Number for Models:			Qty.
		"1" Series	"3" Series	"5" Series	
1	Motor	See Page 9	See Page 9	See Page 10	1
2	Rod	5900-072-00	5900-072-00	5900-072-00	1
3	Coupling	Incl. w/Ref 5	Incl. w/Ref 5	Incl. w/Ref 5	2
4	Socket Head Cap Screw - ISO Class 12.9	* Incl. w/Ref 5	* Incl. w/Ref 5	* Incl. w/Ref 5	4
5	Coupling Kit (includes Ref. Nos. 2, 3, 4)	See Page 9	See Page 9	See Page 10	1
6	O-ring - EPDM	* M2.65×22.4	* M2.65×22.4	* M2.65×22.4	1
7	Shaft Seal - EPDM, Carbon, Tungsten Carbide (Includes Ref. No. 6)	5900-300-00	5900-300-00	5900-300-00	1
8	Adapter	See Page 9	See Page 9	See Page 10	1
9	Shield	See Page 9	See Page 9	See Page 10	2
10	Pan Head Machine Screw	* M4-0.7×8	* M4-0.7×8	* M4-0.7×8	4
11	O-ring - EPDM	* M2.4×17.8	* M2.4×17.8	* M2.4×17.8	3
12	Wash Plug Assembly (Includes Ref. No. 11)	5900-044-90	5900-044-90	5900-044-90	1
13	Vent Plug Assembly (Includes Ref. No. 11)	5900-044-90	5900-044-90	5900-044-90	1
14	Hex Head Cap Screw - SAE Grade 5	* See Page 9	See Page 9	See Page 10	4
15	Hex Nut - ASTM Class A2-70	* M12-1.75	* M12-1.75	* M12-1.75	4
16	Flat Washer - SS	* M12	* M12	* M12	4
17	Staybolt (multiple lengths)	See Page 9	See Page 9	See Page 10	4
18	Spring	5900-036-00	5900-036-00	5900-036-00	1
19	O-ring - EPDM	* M3.5×138	* M3.5×138	* M3.5×138	2
20	Cylinder (multiple lengths)	See Page 9	See Page 9	See Page 10	1
21	Shaft (multiple lengths)	See Page 9	See Page 9	See Page 10	1
22	Retaining Ring	5900-090-00	5900-090-00	5900-090-00	1
23	Collar	5900-086-00	5900-086-00	5900-086-00	1
24	Top Plate Weldment w/Crossover (Standard)	5900-172-00	5900-172-00	5930-172-00	1
24a	Top Plate Weldment (2-Stage Models Only)	5900-170-00	5900-170-00	N/A	1
25	Sleeve 18.0mm (2-Stage Models Only)	5900-094-00	5900-094-00	N/A	1
26	Impeller Weldment	5900-010-00	5920-010-00	5930-010-00	Varies
27	Sleeve 17.5/26.0mm (Standard)	5900-080-00	5900-080-00	5930-090-00	Varies
28	Cap	Incl. w/Ref 30	Incl. w/Ref 30	Incl. w/Ref 30	Varies
29	Wear Ring - Teflon®	Incl. w/Ref 30	Incl. w/Ref 30	Incl. w/Ref 30	Varies
30	Crossover Weldment (Includes 28, 29)	5900-160-00	5900-160-00	5930-160-00	Varies
31	Sleeve 6.5/15.0mm (Bearing Companion)	5900-078-00	5900-078-00	5930-088-00	Varies
32	Bearing Inner - Tungsten Carbide	5900-082-00	5900-082-00	5900-082-00	Varies
33	Bearing Outer - Tungsten Carbide	Incl. w/Ref 34	Incl. w/Ref 34	Incl. w/Ref 34	Varies
34	Crossover Weldment w/Bearing (Includes 28, 29, 33)	5900-162-00	5900-162-00	5930-162-00	Varies
35	Sleeve Cup	5900-076-00	5900-076-00	5900-076-00	1
36	Star Washer	* M8	* M8	* M8	1
37	Hex Nut w/Nyloc	* M8-1.25	* M8-1.25	* M8-1.25	1
38	Volute Weldment (Includes 28, 29)	5900-150-00	5900-150-00	5930-150-00	Varies
39	Casing	5900-001-00	5900-001-00	5900-001-00	1
40	Oval Gasket - EPDM	Incl. w/Ref KIT	Incl. w/Ref KIT	Incl. w/Ref KIT	2
41	NPT Flange	5900-050-01	5900-050-01	5900-050-02	2
42	Hex Head Cap Screw - Class A2-70	* M10-1.50×40	* M10-1.50×40	* M10-1.50×40	4
43	Vent Plug Assembly (Includes Ref. No. 11)	5900-048-90	5900-048-90	5900-048-90	1
44	Hex Head Cap Screw	* 5/8"UNC×2½"	* 5/8"UNC×2½"	* 5/8"UNC×2½"	8
45	Pipe Flange - ANSI/ASME 250# (Outer)	* 1¼" NPT	* 1¼" NPT	* 1¼" NPT	2
46	Pipe Flange - ANSI/ASME 250# (Inner)	* 1" NPT	* 1" NPT	* 1¼" NPT	2
47	Gasket	5900-068-00	5900-068-00	5900-068-00	2
48	Hex Nut	* 5/8"-18UNC	* 5/8"-18UNC	* 5/8"-18UNC	8
49	Pipe Nipple	* 1" NPT	* 1" NPT	* 1¼" NPT	2
50	Pipe Flange Kit - ANSI/ASME 250# (Includes one each: 45, 46, 47, 49; and four each: 44, 48)	5900-064-90	5900-064-90	5900-064-91	2
KIT	Seal Kit - Complete (Includes Ref. Nos. 7, 11, 19, 40)	5900-300-90	5900-300-90	5900-300-90	1

(*) Standard hardware item, available locally.

Repair Parts List (continued)

Model	HP	Ref. No. 1 1 Phase	Motor 3 Phase	Ref. No. 5 Coupling	Ref. No. 8 Adapter	Ref. No. 9 Shield	Ref. No. 14 Cap Screw	Ref. No. 17 Staybolt	Ref. No. 20 Cylinder	Ref. No. 21 Shaft
"1" Series										
2-Stage	3/4	1626-321-00	1626-326-00	5900-070-90	5900-030-00	5900-038-00	3/8"-16UNCx1/4"	5900-702-00	5900-602-00	5900-503-00
3-Stage	3/4	1626-321-00	1626-326-00	5900-070-90	5900-030-00	5900-038-00	3/8"-16UNCx1/4"	5900-702-00	5900-602-00	5900-503-00
4-Stage	3/4	1626-321-00	1626-326-00	5900-070-90	5900-030-00	5900-038-00	3/8"-16UNCx1/4"	5900-704-00	5900-604-00	5900-504-00
5-Stage	3/4	1626-321-00	1626-326-00	5900-070-90	5900-030-00	5900-038-00	3/8"-16UNCx1/4"	5900-705-00	5900-605-00	5900-505-00
6-Stage	3/4	1626-321-00	1626-327-00	5900-070-90	5900-030-00	5900-038-00	3/8"-16UNCx1/4"	5900-706-00	5900-606-00	5900-506-00
7-Stage	3/4	1626-321-00	1626-327-00	5900-070-90	5900-030-00	5900-038-00	3/8"-16UNCx1/4"	5900-707-00	5900-607-00	5900-507-00
8-Stage	1	1626-322-00	1626-328-00	5900-070-90	5900-030-00	5900-038-00	3/8"-16UNCx1/4"	5900-708-00	5900-608-00	5900-508-00
9-Stage	1	1626-322-00	1626-328-00	5900-070-90	5900-030-00	5900-038-00	3/8"-16UNCx1/4"	5900-709-00	5900-609-00	5900-509-00
10-Stage	1	1626-322-00	1626-328-00	5900-070-90	5900-030-00	5900-038-00	3/8"-16UNCx1/4"	5900-710-00	5900-610-00	5900-510-00
11-Stage	1 1/2	1626-323-00	1626-329-00	5900-070-90	5900-030-00	5900-038-00	3/8"-16UNCx1/4"	5900-711-00	5900-611-00	5900-511-00
12-Stage	1 1/2	1626-323-00	1626-329-00	5900-070-90	5900-030-00	5900-038-00	3/8"-16UNCx1/4"	5900-712-00	5900-612-00	5900-512-00
13-Stage	1 1/2	1626-323-00	1626-329-00	5900-070-90	5900-030-00	5900-038-00	3/8"-16UNCx1/4"	5900-713-00	5900-613-00	5900-513-00
15-Stage	2	1626-324-00	1626-330-00	5900-070-90	5900-030-00	5900-038-00	3/8"-16UNCx1/4"	5900-715-00	5900-615-00	5900-515-00
17-Stage	2	1626-324-00	1626-330-00	5900-070-90	5900-030-00	5900-038-00	3/8"-16UNCx1/4"	5900-717-00	5900-617-00	5900-517-00
19-Stage	2	1626-324-00	1626-330-00	5900-070-90	5900-030-00	5900-038-00	3/8"-16UNCx1/4"	5900-719-00	5900-619-00	5900-519-00
21-Stage	3	1626-325-00	1626-331-00	5900-070-90	5900-030-00	5900-038-00	3/8"-16UNCx1/4"	5900-721-00	5900-621-00	5900-521-00
23-Stage	3	1626-325-00	1626-331-00	5900-070-90	5900-030-00	5900-038-00	3/8"-16UNCx1/4"	5900-725-00	5900-623-00	5900-523-00
25-Stage	3	1626-325-00	1626-331-00	5900-070-90	5900-030-00	5900-038-00	3/8"-16UNCx1/4"	5900-725-00	5900-625-00	5900-525-00
27-Stage	3	1626-325-00	1626-331-00	5900-070-90	5900-030-00	5900-038-00	3/8"-16UNCx1/4"	5900-727-00	5900-627-00	5900-527-00
"3" Series										
2-Stage	1	1626-322-00	1626-328-00	5900-070-90	5900-030-00	5900-038-00	3/8"-16UNCx1/4"	5900-702-00	5900-602-00	5900-503-00
3-Stage	1	1626-322-00	1626-328-00	5900-070-90	5900-030-00	5900-038-00	3/8"-16UNCx1/4"	5900-702-00	5900-602-00	5900-503-00
4-Stage	1	1626-322-00	1626-328-00	5900-070-90	5900-030-00	5900-038-00	3/8"-16UNCx1/4"	5900-704-00	5900-604-00	5900-504-00
5-Stage	1	1626-322-00	1626-328-00	5900-070-90	5900-030-00	5900-038-00	3/8"-16UNCx1/4"	5900-705-00	5900-605-00	5900-505-00
6-Stage	1	1626-322-00	1626-328-00	5900-070-90	5900-030-00	5900-038-00	3/8"-16UNCx1/4"	5900-706-00	5900-606-00	5900-506-00
7-Stage	1 1/2	1626-323-00	1626-329-00	5900-070-90	5900-030-00	5900-038-00	3/8"-16UNCx1/4"	5900-707-00	5900-607-00	5900-507-00
8-Stage	1 1/2	1626-323-00	1626-329-00	5900-070-90	5900-030-00	5900-038-00	3/8"-16UNCx1/4"	5900-708-00	5900-608-00	5900-508-00
9-Stage	1 1/2	1626-323-00	1626-329-00	5900-070-90	5900-030-00	5900-038-00	3/8"-16UNCx1/4"	5900-709-00	5900-609-00	5900-509-00
10-Stage	2	1626-324-00	1626-330-00	5900-070-90	5900-030-00	5900-038-00	3/8"-16UNCx1/4"	5900-710-00	5900-610-00	5900-510-00
11-Stage	2	1626-324-00	1626-330-00	5900-070-90	5900-030-00	5900-038-00	3/8"-16UNCx1/4"	5900-711-00	5900-611-00	5900-511-00
12-Stage	2	1626-324-00	1626-330-00	5900-070-90	5900-030-00	5900-038-00	3/8"-16UNCx1/4"	5900-712-00	5900-612-00	5900-512-00
13-Stage	3	1626-325-00	1626-331-00	5900-070-90	5900-030-00	5900-038-00	3/8"-16UNCx1/4"	5900-713-00	5900-613-00	5900-513-00
15-Stage	3	1626-325-00	1626-331-00	5900-070-90	5900-030-00	5900-038-00	3/8"-16UNCx1/4"	5900-715-00	5900-615-00	5900-515-00
17-Stage	3	1626-325-00	1626-331-00	5900-070-90	5900-030-00	5900-038-00	3/8"-16UNCx1/4"	5900-717-00	5900-617-00	5900-517-00
19-Stage	3	1626-325-00	1626-331-00	5900-070-90	5900-030-00	5900-038-00	3/8"-16UNCx1/4"	5900-719-00	5900-619-00	5900-519-00
21-Stage	5	N/A	1626-360-00	5920-070-90	5920-030-00	5920-038-00	1/2"-13UNCx1/4"	5900-721-00	5900-621-00	5900-521-00
23-Stage	5	N/A	1626-360-00	5920-070-90	5920-030-00	5920-038-00	1/2"-13UNCx1/4"	5900-725-00	5900-623-00	5900-523-00

Repair Parts List (continued)

Model	HP	Ref. No. 1 1 Phase	Motor 3 Phase	Ref. No. 5 Coupling	Ref. No. 8 Adapter	Ref. No. 9 Shield	Ref. No. 14 Cap Screw	Ref. No. 17 Staybolt	Ref. No. 20 Cylinder	Ref. No. 21 Shaft
"5" Series										
2-Stage	2	1626-324-00	1626-330-00	5900-070-90	5900-030-00	5900-038-00	3/8"-16UNCx1"	5900-702-00	5900-602-00	5930-503-00
3-Stage	2	1626-324-00	1626-330-00	5900-070-90	5900-030-00	5900-038-00	3/8"-16UNCx1"	5930-703-00	5930-603-00	5930-503-00
4-Stage	2	1626-324-00	1626-330-00	5900-070-90	5900-030-00	5900-038-00	3/8"-16UNCx1"	5900-706-00	5900-606-00	5930-504-00
5-Stage	2	1626-324-00	1626-330-00	5900-070-90	5900-030-00	5900-038-00	3/8"-16UNCx1"	5930-705-00	5930-605-00	5930-505-00
6-Stage	2	1626-324-00	1626-330-00	5900-070-90	5900-030-00	5900-038-00	3/8"-16UNCx1"	5900-709-00	5900-609-00	5930-506-00
7-Stage	2	1626-324-00	1626-330-00	5900-070-90	5900-030-00	5900-038-00	3/8"-16UNCx1"	5930-707-00	5930-607-00	5930-507-00
8-Stage	3	1626-325-00	1626-331-00	5900-070-90	5900-030-00	5900-038-00	3/8"-16UNCx1"	5900-712-00	5900-612-00	5930-508-00
9-Stage	3	1626-325-00	1626-331-00	5900-070-90	5900-030-00	5900-038-00	3/8"-16UNCx1"	5930-709-00	5930-609-00	5930-509-00
10-Stage	3	1626-325-00	1626-331-00	5900-070-90	5900-030-00	5900-038-00	3/8"-16UNCx1"	5900-715-00	5900-615-00	5930-510-00
11-Stage	5	N/A	1626-360-00	5920-070-90	5920-030-00	5920-038-00	1/2"-13UNCx1 1/4"	5930-711-00	5930-611-00	5930-511-00
12-Stage	5	N/A	1626-360-00	5920-070-90	5920-030-00	5920-038-00	1/2"-13UNCx1 1/4"	5930-712-00	5930-612-00	5930-512-00
13-Stage	5	N/A	1626-360-00	5920-070-90	5920-030-00	5920-038-00	1/2"-13UNCx1 1/4"	5930-713-00	5930-613-00	5930-513-00
14-Stage	5	N/A	1626-360-00	5920-070-90	5920-030-00	5920-038-00	1/2"-13UNCx1 1/4"	5900-721-00	5900-621-00	5930-514-00
15-Stage	5	N/A	1626-360-00	5920-070-90	5920-030-00	5920-038-00	1/2"-13UNCx1 1/4"	5930-715-00	5930-615-00	5930-515-00
16-Stage	5	N/A	1626-360-00	5920-070-90	5920-030-00	5920-038-00	1/2"-13UNCx1 1/4"	5930-716-00	5930-616-00	5930-516-00
18-Stage	7 1/2	N/A	1626-361-00	5930-070-90	5920-030-00†	5920-038-00	1/2"-13UNCx1 3/4"	5900-727-00	5900-627-00	5930-518-00
20-Stage	7 1/2	N/A	1626-361-00	5930-070-90	5920-030-00†	5920-038-00	1/2"-13UNCx1 3/4"	5930-720-00	5930-620-00	5930-520-00
22-Stage	7 1/2	N/A	1626-361-00	5930-070-90	5920-030-00†	5920-038-00	1/2"-13UNCx1 3/4"	5930-722-00	5930-622-00	5930-522-00
24-Stage	7 1/2	N/A	1626-361-00	5930-070-90	5920-030-00†	5920-038-00	1/2"-13UNCx1 3/4"	5930-724-00	5930-624-00	5930-524-00
26-Stage	5*	N/A	1626-361-00	5930-070-90	5920-030-00†	5920-038-00	1/2"-13UNCx1 3/4"	5930-726-00	5930-626-00	5930-526-00
29-Stage	5*	N/A	1626-361-00	5930-070-90	5920-030-00†	5920-038-00	1/2"-13UNCx1 3/4"	5930-729-00	5930-629-00	5930-529-00

(†) Adapter requires Disk 5930-035-00

(*) 50 Hertz only

(◆) 1/2 HP No Longer Available

IMPORTANT: This replacement shaft seal may look different than your current seal, be sure to install properly.

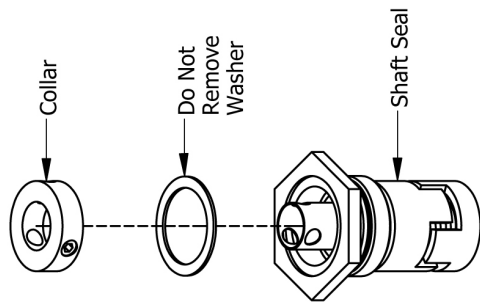

Generation I

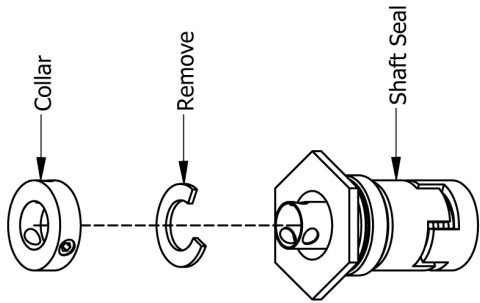

Generation II

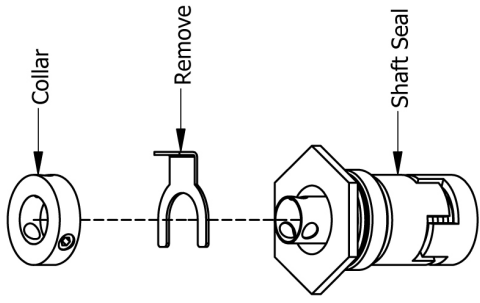

Generation III

NOTE: Assembly shown exploded for illustration purposes only (do not separate collar from seal).

See owner's manual for detailed instructions:

1. Install shaft seal.
2. Adjust shaft height and tighten set screws in seal collar.
3. Attach shaft coupling.
4. Remove washer shown above to reveal required clearance gap shown below.

CAUTION To avoid damage to pump, be sure to remove washer which provides adequate clearance shown below.

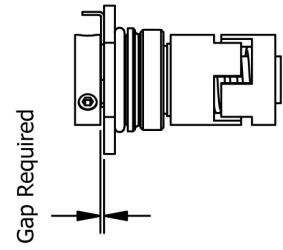
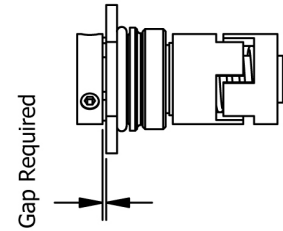
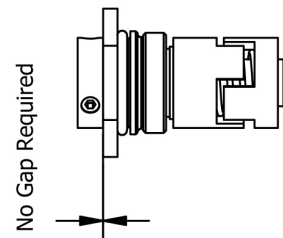
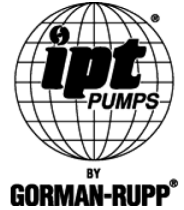

Figure 8 - Replacement Shaft Seal



American Machine & Tool Co., Inc. of PA
(herein "AMT")
400 Spring Street
Royersford, PA 19468
Phone: (610) 948-3800
Fax: (610) 948-5300
www.amtpump.com



General Information

SALES POLICY: AMT products are sold through our established Distributors. We do not sell direct to the consumer or organization not entitled to trade recognition. Therefore, possession of our catalogs and/or price list(s) does not infer an offer to sell.

MINIMUM ORDER: We appreciate your order, however, all orders are subject to a minimum \$35.00 net invoice charge (excluding freight). This applies to all pump and parts purchase orders.

PRICES: Prices are subject to change without notice. All orders accepted are subject to prices in effect at time of shipment.

PAYMENT TERMS: Terms, upon establishment of credit, are Net 30 days. Past due accounts may be subject to a service charge of 1.5% per month. Domestic or assignable letter of credit is required for all export trade.

PAST DUE ACCOUNTS: AMT reserves the right to withhold open account shipments on any past due account. Invoices are considered past due after thirty (30) days. In the interest of sound business, all orders are subject to approval of the Credit Department.

SHIPPING INSTRUCTIONS: All shipments will be made F.O.B. the factory. Where instructions for shipment do not appear on the order, the shipment will be made according to our best judgment. Full risk of loss (including transportation delays and losses) shall pass to the customer upon delivery of the products to the carrier at the F.O.B. point. When loss or delay occurs, primary responsibility for tracing rests with the customer. When there is LOSS or APPARENT VISIBLE DAMAGE to a shipment, when tendered for delivery, *DO NOT* give the carrier a clear receipt. Note such damage on the carrier's delivery receipt and *HAVE THE DRIVER SIGN THE RECEIPT.*

PRODUCT REVISIONS: AMT reserves the right to discontinue, change or improve its products or any portions thereof without being obligated to provide such a change or improvement for units sold and/or shipped prior to such a change or improvement.

LEAD TIME: Products designated "Quick Ship Product", also referred to as "QSP" will normally be shipped within 24 hours of receipt of a non-cancellable purchase order. Only limited quantities of "QSP" pumps are available.

STANDARD LEAD TIME: Lead time is two weeks for all non "QSP" product. AMT reserves the right to revise lead times as required due to availability of materials and all other causes beyond our control.

VIP SHIPMENT: Select AMT and IPT branded pumps are available for next day shipment for non-QSP (Quick Ship Products) items and subjected to a specific model surcharge per unit noted in the respective price book. Requires calling for availability, confirmation and a non-cancellable purchase order or credit card payment prior to shipment. The expedited shipping charges are an additional cost added separately from the VIP charges per item. AMT reserves the right to revise lead times as required due to availability of materials and all other causes beyond our control. QSP quantities are limited as determined by AMT.

ALL purchase orders must be submitted via hard copy sent to AMT customer service department by fax, EDI or e-mail.

RETURN GOODS POLICY: Goods shall not be returned without a return goods authorization number (RGA) issued by AMT customer service. The RGA number must be listed on the packing list. Only current model and part numbers with a valid date code may be returned (within one year from date of purchase). **A 20% restocking and packaging charge will apply to all returns. All shipping charges must be pre-paid. No exceptions.**

ORDER CHANGES BY CUSTOMER: Orders in process may not be changed except with written consent and may be subject to special charges.

12 Month Limited Warranty

EXTENT AND DURATION OF LIMITED WARRANTY

Coverage: American Machine & Tool Company (herein "AMT") or IPT Pumps by Gorman-Rupp (herein "IPT") or Gorman-Rupp Industries Division of The Gorman-Rupp Company, Patterson, or the Gorman-Rupp Company (herein referred to as "G-R Unit") each individually warrants that its products and parts shall be free from defects in material and workmanship for twelve (12) months from the date of purchase by the original end user when installation is made and maintenance is performed in accordance with G-R Unit's recommendations. Wear and tear resulting from use and items normally consumed in use are not covered.

EXCEPTIONS

(A) This Limited Warranty shall not apply to mechanical seals in AMT or IPT pumps and the following products and parts: engines, motors, trade accessories and all other products, components, parts and materials not manufactured by the G-R Units. These items may, however, be covered by the warranties of their respective manufacturers. (B) This warranty does not extend to or apply to any unit which has been repaired or altered at any place other than by a G-R Unit, or by persons not expressly approved by a G-R Unit to make repairs or alterations, nor to any unit the serial number, model number or identification of which has been removed, defaced or altered. (C) This warranty does not extend to any product manufactured by a G-R Unit, which has been subjected to mis-use, neglect, accident, improper installation, or use in violation of instructions furnished by a G-R Unit. (D) Pump Kits: This warranty does not extend to any product sold by a G-R Unit unassembled as a Pump Kit. Pump Kits are warranted against defects in material and workmanship for 60 days from the date of shipment from a G-R Unit. Any Pump Kit parts deemed defective by a G-R Unit will be replaced free of charge within 60 days of shipment. Pump Kits are not returnable for credit.

LIMITATIONS

THE G-R UNITS' SOLE AND EXCLUSIVE WARRANTY WITH RESPECT TO THEIR PRODUCTS AND PARTS IS THIS LIMITED WARRANTY. THIS LIMITED WARRANTY IS IN LIEU OF ALL OTHER EXPRESS AND/OR IMPLIED WARRANTIES, INCLUDING IMPLIED WARRANTIES OF MERCHANTABILITY AND FITNESS FOR PARTICULAR PURPOSE.

EXCLUSIVE REMEDY AND DAMAGES

The sole and exclusive remedy for breach of this Warranty by a G-R Unit and the entire extent of its liability for such breach or for damages arising from the use of the products and parts covered under this Limited Warranty, shall be as follows:

- Repair or Replacement:** If inspection shows that any G-R Unit product or part covered under this Limited Warranty is defective in materials or workmanship, the G-R Unit shall repair or replace the defective or non-conforming product or part without charge, whichever the G-R Unit chooses. You must have properly maintained and used the product or part claimed to be defective in accordance with the maintenance schedule or manual, which comes with the product. No allowance will be made for labor, installation, removal, transportation or other charges incurred by you in connection with such repair or replacement.
- To obtain the above remedy:
 - Immediately notify the G-R Unit upon discovery of the claimed defect in materials or workmanship and provide the serial number or date code of the product and/or part(s) or provide the G-R Unit with the invoice or bill of sale referencing the product by no later than the expiration date of the warranty period.
 - The G-R Unit will advise whether inspection will be necessary and how whether repair or replacement will be made. If inspection by the G-R Unit is necessary, the pump or defective part must be sent freight pre-paid to the G-R Unit. Return shipment will be F.O.B. the G-R Unit's plant.
 - Return Goods Authorization Requirement:** No product will be accepted for return or replacement without the prior written authorization of the G-R Unit. Upon such authorization, and in accordance with instructions from the G-R Unit, the product will be returned to the G-R Unit, shipping charges prepaid by the Buyer.
- Damages:** The G-R Unit's liability for damages for breach of this Limited Warranty shall not exceed the amount of the purchase price of the product or part(s) in respect to which Such damages are claimed. **IN NO EVENT SHALL THE G-R UNITS BE LIABLE FOR INCIDENTAL, CONSEQUENTIAL OR SPECIAL DAMAGES FOR BREACH OF THIS LIMITED WARRANTY.**

Some states do not allow the exclusion or limitation of incidental or consequential damages, so the above limitation or exclusion may not apply to you. This Limited Warranty gives you specific legal rights, and you may also have other rights, which vary from state to state.