

BALDOR® • **RELIANCE**

Product Information Packet

VHEM2538T

40HP,3540RPM,3PH,60HZ,286HP,1046M,OPEN,F

Part Detail							
Revision:	B	Status:	PRD/A	Change #:		Proprietary:	No
Type:	AC	Prod. Type:	1046M	Elec. Spec:	10WGY796	CD Diagram:	CD0180
Enclosure:	OPEN	Mfg Plant:		Mech. Spec:	10F886	Layout:	10LYF886
Frame:	286HP	Mounting:	F1	Poles:	02	Created Date:	07-09-2015
Base:	N	Rotation:	R	Insulation:	F	Eff. Date:	04-05-2016
Leads:	9#8					Replaced By:	
Literature:		Elec. Diagram:					

Nameplate NP2138L												
CAT.NO.	VHEM2538T			P/N				ENCLOSURE	OPEN			
SPEC.	10F886Y796G1		CC	010A		FRAME	286HP		S/N			
HP	40			CLASS	F		HZ	60				
RPM	3540			PH	3		DES	B				
VOLT	230/460				KVA-CODE	G		ODE BRG	6309		DE BRG	6312
AMP	92/46			USABLE AT 208V								
RATING	40C AMB-CONT			GREASE	POLYREX EM							
NEMA-NOM-EFF	92.4	PF	88	SER.F.	1.15							
HTR-VOLTS			HTR-AMPS			MAX. SPACE HEATER TEMP.						

Parts List		
Part Number	Description	Quantity
SA303600	SA 10F886Y796G1	1.000 EA
RA290732	RA 10F886Y796G1	1.000 EA
S/P107-000-004	SUPER-E(284 FR. & UP)-CL PLANT,POLYREX E	1.000 EA
10CB3003A04	KO BOX, MACH W/2.00 NPT LD HL & #26 DRAI	1.000 EA
12GS1000SP	GASKET	1.000 EA
10XN3118K16	5/16-18 X 1' GRADE #5, STL, ZINC PLATE	4.000 EA
HW1001A31	LOCKWASHER 5/16, ZINC PLT.591 OD, .319 I	4.000 EA
WD1000B16	T&B CX70TN TERMINAL	1.000 EA
51XF2520A08	SCREW, HEX SER SLT HD, ZN 1/4-20 X .50 L	1.000 EA
10EP1201A01	FREP, MACH W/309 BRG	1.000 EA
10AD2002	AIR DEFLECTOR, 310 OPEN P-BASE	1.000 EA
12XN1032A08	10-32X1/2 HEX HD SLTD	3.000 EA
HW1001A10	WASHER, #10 SPLT LK, ZN X	3.000 EA
10XN3816K52	3/8-16 X 3-1/4 HEX HEAD CAP SCREW GRD 5	4.000 EA
HW1001A38	LOCKWASHER 3/8, ZINC PLT .688 OD, .382 I	4.000 EA
HW4600B41	V-RING SLINGER 2.125 X 2.880 X 0.280	1.000 EA
HW5100A11	W3917-042 WVY WSHR (WB)	1.000 EA
10XN3118K80	.31-18 X 5.0 HEX HD CAP SCREW, GRADE 5	4.000 EA
HW1001A31	LOCKWASHER 5/16, ZINC PLT.591 OD, .319 I	4.000 EA
10EP1507A02	ENDPLATE, MACH W/312 BRG	1.000 EA
10XN3816K44	3/8-16 X 2.75 HEX HD CAP SCREW, GRADE 5	4.000 EA
HW1001A38	LOCKWASHER 3/8, ZINC PLT .688 OD, .382 I	4.000 EA
10FH1500A01	DRIP COVER, MACH	1.000 EA
HW3201A12	.50-13 EYEBOLT W/2.25 SHANK	2.000 EA

Parts List (continued)		
Part Number	Description	Quantity
HW1001A50	LOCKWASHER 1/2, ZINC PLT.,.879 OD, .509 I	2.000 EA
HW1000A50	1/2 SAE FLAT WASHERS	2.000 EA
10CB3501	CONDUIT BOX LID FOR 10CB3003, 10CB3004 &	1.000 EA
14GS1001	GASKET, CONDUIT BOX LID 314 FRAME	1.000 EA
10XN2520K16	1/4-20 X 1" HX HD SCRW GRADE 5, ZINC P	4.000 EA
HW1001A25	LOCKWASHER 1/4, ZINC PLT .493 OD, .255 I	4.000 EA
HW2501E11	KEY, 1/4 SQ X 1.125	1.000 EA
LB1182	WARNING LABEL FOR MOTORS WITH EYENUTS	2.000 EA
HW4500A03	GREASE FITTING, .125 NPT 1610(ALEMITE) 8	1.000 EA
HW4500A17	317400 ALEMITE GREASE RELIEF	1.000 EA
HA4051A00	PLASTIC CAP FOR GREASE FITTING	1.000 EA
MG1025G05	WILKOFASST, 789.227, MED. GRAY CHAR. MET.	0.200 GA
MJ1000A02	GREASE, POLYREX EM EXXON (USe 4824-15A)	0.130 LB
HW4500A03	GREASE FITTING, .125 NPT 1610(ALEMITE) 8	1.000 EA
HW4500A17	317400 ALEMITE GREASE RELIEF	1.000 EA
HA4051A00	PLASTIC CAP FOR GREASE FITTING	1.000 EA
85XU0407S04	4X1/4 U DRIVE PIN STAINLESS	4.000 EA
LB1119N	WARNING LABEL	1.000 EA
LC0181	CONNECTION LABEL	1.000 EA
NP2138L	ALUM SUPER-E UL CSA-EEV PREM CC (300	1.000 EA
12PA1030	PACKAGING GROUP PRINT PK1024A06	1.000 EA
PK6538	2X4 X 11 SPACER	2.000 EA
MN416A01	TAG-INSTAL-MAINT no wire (1200/bx) 11/14	1.000 EA

AC Induction Motor Performance Data

Record # 31966 - Typical performance - not guaranteed values

Winding: 10WGY796-R001	Type: 1046M	Enclosure: OPSB
-------------------------------	--------------------	------------------------

Nameplate Data				460 V, 60 Hz: High Voltage Connection	
Rated Output (HP)	40			Full Load Torque	60 LB-FT
Volts	230/460			Start Configuration	direct on line
Full Load Amps	92/46			Breakdown Torque	183 LB-FT
R.P.M.	3540			Pull-up Torque	67.7 LB-FT
Hz	60	Phase	3	Locked-rotor Torque	99.4 LB-FT
NEMA Design Code	B	KVA Code	G	Starting Current	288 A
Service Factor (S.F.)	1.15			No-load Current	10.5 A
NEMA Nom. Eff.	92.4	Power Factor	88	Line-line Res. @ 25°C	0.195 Ω
Rating - Duty	40C AMB-CONT			Temp. Rise @ Rated Load	33°C
S.F. Amps				Temp. Rise @ S.F. Load	41°C
				Locked-rotor Power Factor	24
				Rotor inertia	1.97 LB-FT ²

Load Characteristics 460 V, 60 Hz, 40 HP

% of Rated Load	25	50	75	100	125	150	S.F.
Power Factor	65	81	87	89	90	88	90
Efficiency	88	91.9	92.8	92.7	92.3	92.3	92.5
Speed	3583	3567	3551	3531	3510	3484	3518
Line amperes	15.3	24.4	34.3	45.1	55.8	69.5	51.5

Performance Graph at 460V, 60Hz, 40.0HP Typical performance - Not guaranteed values

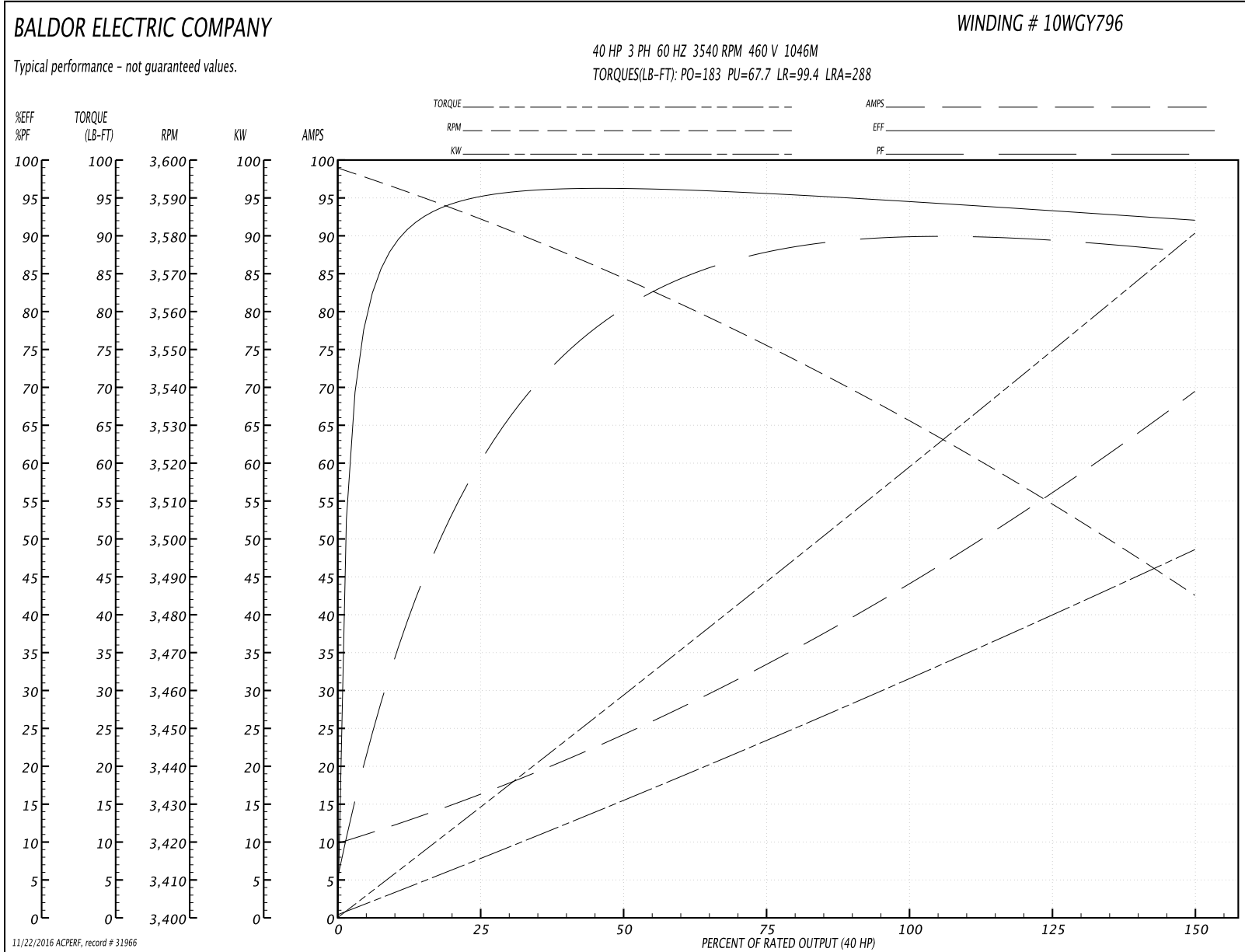

10LYF886

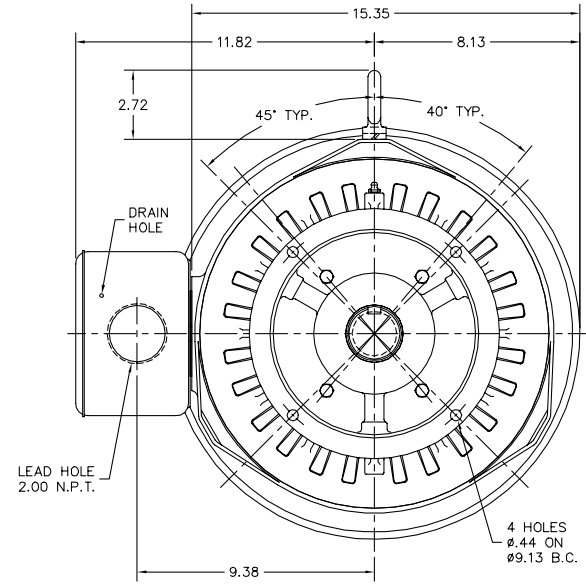
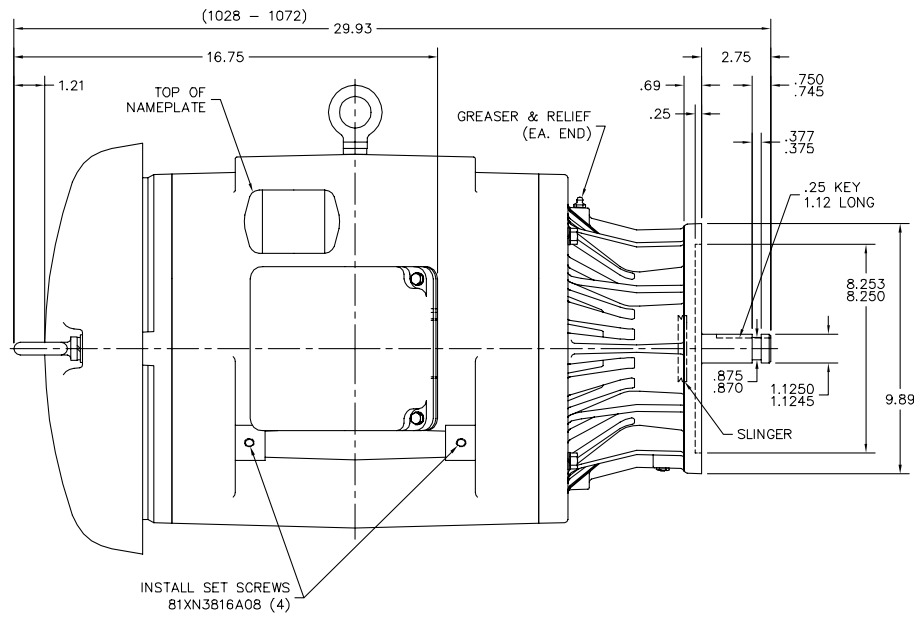

10LYF886

CUSTOMER IS RESPONSIBLE FOR DETERMINING THAT BALDOR'S PRODUCT WILL PERFORM SUITABLY IN THE INTENDED APPLICATION.

REV. DESC: UPDATED DESCRIPTION		
REV. LTR: C	VERSION: 03	TDR: 000000855727
FILE: \AAA\00123\482	REVISED: 12:37:21 05/29/2014	BY: ENNINDO
MTL: -		

BALDOR
VERT OPEN 284-6HP W/312 BRG
SH 1 of 1

CD0180

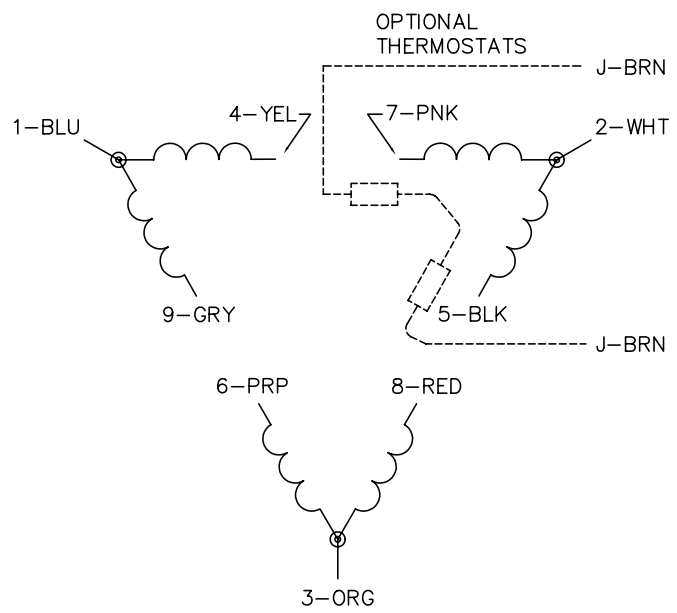

LOW VOLTAGE (2D)

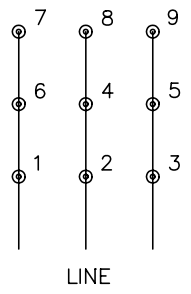

HIGH VOLTAGE (1D)

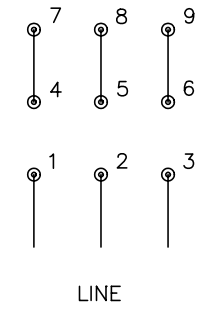

NOTES:

1. INTERCHANGE ANY TWO LINE LEADS TO REVERSE ROTATION.
2. OPTIONAL THERMOSTATS ARE PROVIDED WHEN SPECIFIED.
3. ACTUAL NUMBER OF INTERNAL PARALLEL CIRCUITS MAY BE A MULTIPLE OF THOSE SHOWN ABOVE.
4. LEAD COLORS ARE OPTIONAL. LEADS MUST ALWAYS BE NUMBERED AS SHOWN.

REV. DESC: REVISE TO SHOW OPTIONAL COLORS			
REV. LTR: C	BY: JLP	REVISED: 01/21/99 2:28	TDR: 0171435
0810D0		FILE: AAA00005148	MDL: -
		MTL: -	

BALDOR ELECTRIC Co.

3PH, DV, 9 LEADS, DELTA CONNECTION

CD0180