

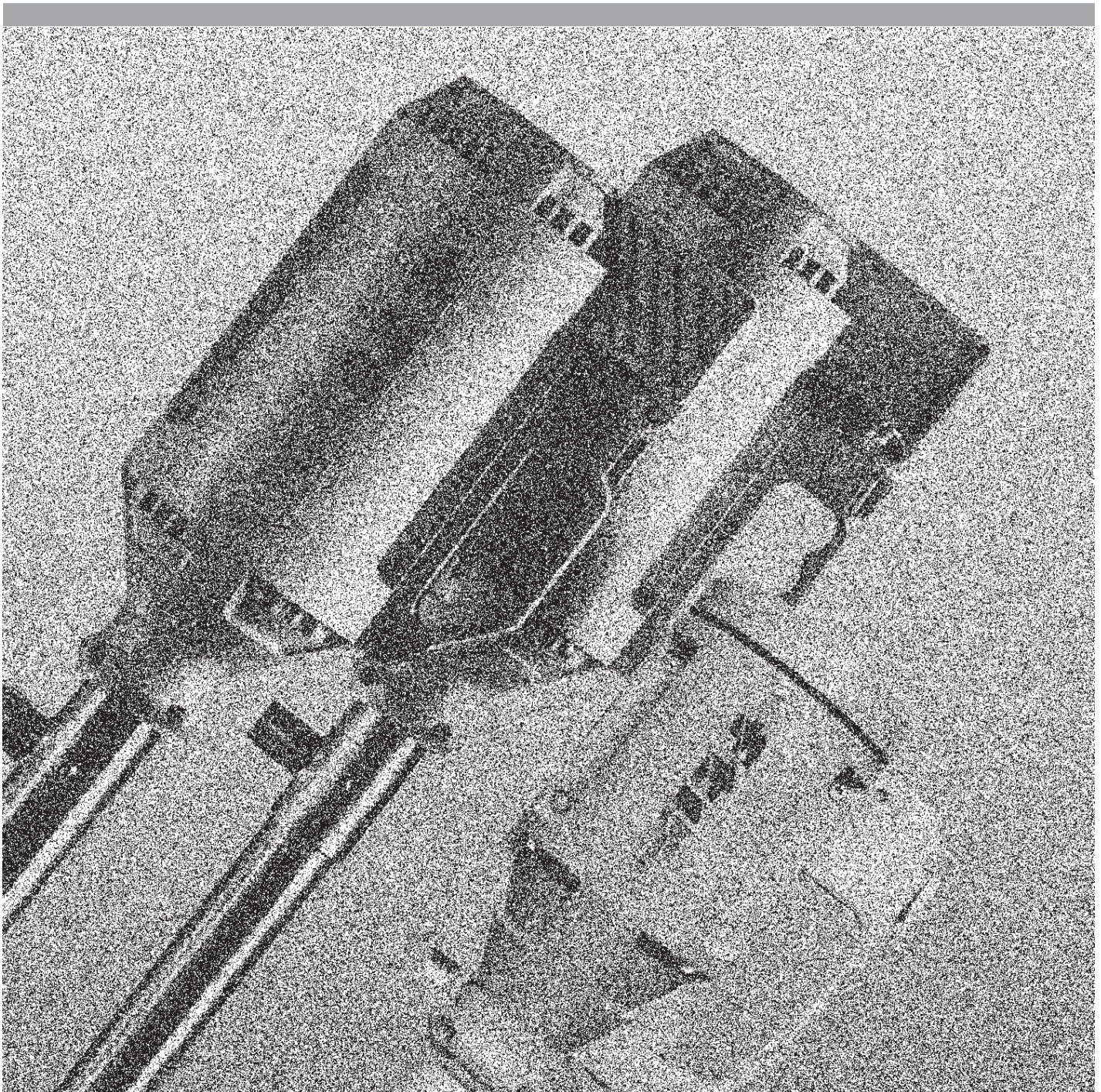

FINISH THOMPSON INC.

OPERATION AND PARTS MANUAL

M SERIES ELECTRIC DRUM PUMP MOTORS



Models: M3 M5 M3T (P/N A101128) M3X M5T (P/N A101132) M5X M7T M7X M10X
M15-M17 M24X-M26X M27-M29 M33X M34X M39 M40 M58P M59P M58H M59H

Order Online: www.PumpCatalog.com



FINISH THOMPSON INC.

921 Greengarden Road • Erie, PA 16501-1591 U.S.A.
Ph 814-455-4478 • Fax 814-455-8518
Email fti@finishthompson.com • www.finishthompson.com

EU Declaration of Conformity



Finish Thompson Inc. hereby declares that the following electrical equipment fully complies with the applicable health and safety requirements as specified by the EU directives listed. The product may not be taken into service until it has been established that the driven Drum and Container Pump complies with the provisions of all relevant EU Directives provided pumps manufactured by Finish Thompson are used.

This declaration is valid provided that the devices are fully assembled and no modifications are made to these devices.

Type of Device:

Electric Motors for Driving Drum
and Container Pumps

Models:

M3V-UK M5 M5T M5V M5X M10X
M13 M59P M59H S2 S3

EU Directives (and their applicable amendments):

Low Voltage (2014/35/EU)
Electromagnetic Compatibility (2014/30/EU)

Specific standards applied:

EN 60335-1 EN60335-2-41
EN 55014-1 EN 55014-2
EN 60529

Signed,



Casey D. Bowes
CEO and President

20 April 2016

Person(s) Authorized to Compile Technical File: Finish Thompson GmbH
Otto-Hahn-Strasse 16
Maintal, D-63477 DEU
Telephone: 49 (0)6181-90878-0



FINISH THOMPSON INC.

921 Greengarden Road • Erie, PA 16501-1591 U.S.A.
Ph 814-455-4478 • Fax 814-455-8518
Email fti@finishthompson.com • www.finishthompson.com

EU DECLARATION OF CONFORMITY

Finish Thompson Inc. hereby declares that the following machines fully comply with the applicable health and safety requirements as specified by the EU Directives listed. This declaration is valid provided that the devices are fully assembled and no modifications are made to these machines.

Type of Device:
Pump Motor

Pump Motor Models:
M10X

EU Directives:
Equipment and protective systems intended for use in potentially
explosive atmospheres (2014/34/EU)

EC-Type Examination:
Physical Technical Testing Institute 1026
Ostrava-Radvanice
FTZU 08 ATEX 0083X

Product Quality Assurance Notification:
Physical Technical Testing Institute 1026
Ostrava-Radanice
FTZU 08 ATEX Q 003

Applicable Harmonized Standards:
EN 60079-0:2012
EN 60079-1:2014

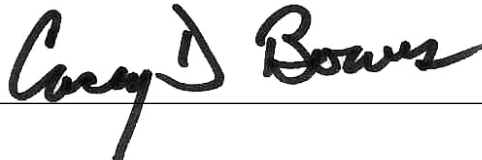

Casey D. Bowes
CEO and President
April 20, 2016

TABLE OF CONTENTS

TABLA DE CONTENIDO

Introduction.....	5	Introducción	5
Warranty and Return Policy	5	Garantía y Póliza de Devolución	5
Safety Precautions.....	6	Precauciones de Seguridad	6
Maintenance Precautions	6	Precauciones de Mantenimiento	6
Important Safety Information for Pumping	7	Important Safety Information for Pumping	7
Flammable or Hazardous Substances		Flammable or Hazardous Substances	
Installation.....	8	Instalación	8
M3 & M5 Models	11	Modelos M3& M5	11
Assembly Drawing and Parts List		Dibujo de Armadura y Lista de Partes	
M3T & M5T Models.....	12	Modelos M3T & M5T.....	12
Assembly Drawing and Parts List		Dibujo de Armadura y Lista de Partes	
M7T Models.....	13	Modelos M7T.....	13
Assembly Drawing and Parts List		Dibujo de Armadura y Lista de Partes	
M58P-M59P Models.....	14	Modelos M58P, M59P.....	14
Assembly Drawing and Parts List		Dibujo de Armadura y Lista de Partes	
M3X, M5X, M7X & M10X Models.....	15	Modelos M3X, M5X, M7X & M10X.....	15
BT Electric Models	15	Modelos Electricos de BT.....	15
Assembly Drawing and Parts List		Dibujo de Armadura y Lista de Partes	
HVDP Series Motor Assembly	16	HVDP Series Motor Assembly	16
M58H-M59H Models	17	Modelos M58H, M59H.....	17
Assembly Drawing and Parts List		Dibujo de Armadura y Lista de Partes	
Static Protection Kit.....	18	Guias para el Equipo de Protección Estático ...	19

INTRODUCTION

FTI has been an international designer and manufacturer of drum pumps and mixers for over twenty years. We make drum pump selection easy with our complete line of interchangeable motors and tubes. When properly installed and operated, your Finish Thompson drum pump or mixer will provide long, trouble free service.

WARRANTY

Finish Thompson, Inc (manufacturer) warrants this product to be free of defects in materials and workmanship for a period of one year from date of purchase by original purchaser. If a warranted defect, which is determined by manufacturer's inspection, occurs within this period, it will be repaired or replaced at the manufacturer's option, provided (1) the product is submitted with proof of purchase date and (2) transportation charges are prepaid to the manufacturer. Liability under this warranty is expressly limited to repairing or replacing the product or parts thereof and is in lieu of any other warranties, either expressed or implied. This warranty does apply only to normal wear of the product or components. This warranty does not apply to products or parts broken due to, in whole or in part, accident, overload, abuse, chemical attack, tampering, or alteration. The manufacturer accepts no responsibility for product damage or personal injuries sustained when the product is modified in any way. If this warranty does not apply, the purchaser shall bear all cost for labor, material and transportation.

Manufacturer shall not be liable for incidental or consequential damages including, but not limited to process down time, transportation costs, costs associated with replacement or substitution products, labor costs, product installation or removal costs, or loss of profit. In any and all events, manufacturer's liability shall not exceed the purchase price of the product and/or accessories.

Warranty Registration

Thank you for your purchase of this quality Finish Thompson product. Be sure to take a minute to register your pump at Finishthompson.com/warranty. Simply provide the model number, serial number and a few other pieces of information.

RETURN POLICY

Should you have any problems with this product, please contact the distributor in your area. The distributor will then determine if a return to the factory is necessary and will contact the factory for a return authorization number.

Call our toll free Technical Service Hot Line, 1-800-888-3743, if you have any questions regarding product operation or repair.

INTRODUCCIÓN

FTI ha sido diseñador y fabricante internacional de bombas de tambor y mezcladoras por más de veinte años. Hacemos selección de bombas de tambor fácil con nuestra línea completa de motores y tubos intercambiables. Cuando se instala y se maneja correctamente, su bomba de tambor o mezcladora Finish Thompson le dará servicio por un largo tiempo y sin problemas.

GARANTÍA

Finish Thompson, Inc (el fabricante) garantiza este producto contra todo defecto de materiales y mano de obra durante un periodo de un año des de la fecha de adquisición por parte del comprador original. Si, dentro de este periodo, se detecta algún defecto cubierto por la garantía mediante una inspección del fabricante, éste se encargará de corregirlo, mediante reparación o sustitución, a su elección, siempre y cuando: (1) el producto le sea devuelto con algún comprobante de la fecha de compra y (2) a portes pagados. La responsabilidad de esta garantía se limita expresamente a la reparación o sustitución del producto o de partes del mismo, y sustituye a cualquier otra garantía expresa o implícita. Esta garantía sólo se aplica al desgaste del producto o de sus componentes derivado del uso normal. No es aplicable a productos o piezas cuya rotura se deba, en todo o en parte, a accidentes, sobrecargas, abusos, agresión química, manipulación o alteración. El fabricante declina toda responsabilidad por daños en el producto o lesiones personales que se produzcan después de modificar el producto en cualquier forma. Si el comprador no hace valer esta garantía, deberá asumir todos los gastos de mano de obra, material y transporte.

El fabricante no es responsable de los daños consecutivos o resultantes incluidos, aunque sin limitación, los relacionados con la parada de procesos, costes de transporte, costes asociados a la sustitución de productos, costes de mano de obra, costes de retirada o instalación de productos, o pérdida de beneficios. En cualquier caso, la responsabilidad del fabricante no sobrepasará el precio de compra del producto y/o los accesorios.

PÓLIZA DE DEVOLUCIÓN

Si usted tiene cualquier problema con este producto, por favor póngase en contacto con el distribuidor en su area. Entonces el determinará si una devolución a la fábrica es necesaria y se pondrá en contacto con la fábrica para obtener un número de autorización de devolución.

Llame nuestro servicio técnico al numero 814-455-4478 si tiene preguntas de operación o reparación.

SAFETY PRECAUTIONS

ALWAYS wear protective clothing, eye protection and follow standard safety procedures when handling corrosive or personally harmful materials.

NEVER use a plastic pump or an open, splashproof or TEFC motor when pumping or mixing flammable or combustible material.

ALWAYS use and store in an upright position.

NEVER immerse motor in liquid.

ALWAYS place motor in the OFF position prior to connecting the power source.

ALWAYS check motor label plate for the correct power supply requirements.

ALWAYS have manufacturer, its service agent or similarly qualified persons replace supply cord if damaged in order to avoid a hazard.

ALWAYS use an approved plug for Class I, Division 1, Group C & D applications on the X Series motors.

Noise level at a distance of 3 feet:

M3, M5	73 db (Splash proof)
M3T, M5T	77 db (Totally enclosed fan cooled)
M58P & M59P	85 db (800 watt)

MAINTENANCE PRECAUTIONS

ALWAYS store motor upright and away from corrosive liquids and vapors.

Motor Models M3, M3T, M5, M5T, M58P and M59P are 10,000 rpm. Motor brushes in these models should be replaced every 200-300 operating hours to assure trouble free service.

Motor Models M3, M3T, M5, M5T, M7T, M8T, M58P and M59P contain a circuit breaker (overload). If motor will not operate, check the circuit breaker.

Motor Models M3X and M5X have a 400-600 operating hour brush life. Model M10X has a 200-300 operating hour brush life. M3X, M5X and M10X motor brushes require factory replacement.

PRECAUCIONES DE SEGURIDAD

SIEMPRE use ropa protectora, protección para los ojos y siga procedimientos de seguridad básicos cuando maneje materiales corrosivos.

NUNCA use una bomba de plástico en los motores abiertos, contra salpiqueos o TEFC cuando se bombéa o se mezcla materiales combustibles o inflamables.

SIEMPRE use y almacene recto.

NUNCA sumerga el motor en líquido.

SIEMPRE ponga el motor en la posición OFF antes de conectar la corriente eléctrica.

SIEMPRE revise la placa por los requerimientos correctos de corriente eléctrica.

SIEMPRE use un enchufe aprobado para la Clase I, la Division 1, las aplicaciones de los Grupos C & D en el motor de la Serie X.

Nivel de ruido a una distancia de 3 pies:

M3, M5	73 db (Contra alpiqueos)
M3T, M5T	77 db (Totalmente sellada con ventilación)
M58P y M59P	85 db (800 watt)

PRECAUCIONES DE MANTENIMIENTO

SIEMPRE guarde el motor en una posición vertical lejos de líquidos o vapores corrosivos.

Modelos de motor M3, M3T, M5, M5T, M58P y M59P operan a 10,000 rpm. Los cepillos de motor en estos modelos deben ser reemplazados cada 200-300 horas de operación para asegurarse de un servicio libre de problemas.

Modelos de motor M3, M3T, M5, M5T, M7T, M8T, M58P y M59P contienen un disyuntor (sobrecarga). Si el motor no opera, revise el disyuntor.

Los modelos M3X y M5X del motor tienen una vida del cepillo de la hora de funcionamiento 400-600. El modelo M10X tiene una vida del cepillo de la hora de funcionamiento 200-300. Los cepillos del motor de M3X, de M5X y de M10X requieren el reemplazo de la fábrica.

IMPORTANT SAFETY INFORMATION FOR PUMPING FLAMMABLE OR HAZARDOUS SUBSTANCES

Read these instructions before operating the pump and motor equipment. The manufacturer will not be responsible for any damage to property or to persons caused by improper use of the equipment.

⚠ WARNING: It is the responsibility of the user to operate the pump in conformance with OSHA rules for dispensing liquids. Pump containers should be grounded when using with flammable or combustible liquids to avoid static electricity.

1. Use only an explosion-proof rated electric or non-electric (air) motors on stainless steel pump tubes with a Static Protection Kit when transferring flammable or combustible liquids.

⚠ WARNING: Never use an open, splash-proof, TEFC, battery-operated or non-explosion-proof rated motor or a plastic pump tube when transferring flammable or combustible liquids.

2. When operating a drum pump (especially when pumping flammable, combustible or hazardous liquids) follow all electrical and safety codes.

a) In the United States: the United States Occupational Safety and Health Act (OSHA), most recent National Electrical Code (NEC), National Fire Protection, Inc. (NFPA) Code 30 (Flammable and Combustible Code), NFPA 77 (Static Electricity), NFPA 251 (Standard Method of fire Test of Building Construction), NFPA 704 (Identification of the Fire Hazards of Materials), and other NFPA codes, local codes and ordinances.

b) Outside the United States: the ATEX equipment directive 2014/34/EU where applicable, the ATEX workplace 99/92/EC directive where applicable, in addition the precautions of the U.S. codes listed herein and all other local codes and ordinances.

3. Pumping hazardous, flammable, or combustible liquids should only be done in buildings, rooms, or areas suited for this purpose. (See NFPA 30, NFPA 78, NFPA 80, NFPA 251, NFPA 704, other suitable NFPA codes, OSHA, ATEX workplace 99/92/EC directive insurance companies, and other local codes and ordinances.)
4. When filling cans, drums, etc. with combustible or flammable liquids, both container pumping from and container pumping to, should be bonded and grounded to dissipate possible accumulations of static electricity, and minimize sparks caused by static electricity (refer to NFPA 77 and CLC/TR 60079-32-1 for specific details).

⚠ WARNING: Avoid splashing. Splash filling can create static electricity and is extremely hazardous. Reduce motor speed to prevent splashing.

⚠ WARNING: Fluid velocity must be 3 feet/0.9 meter/second maximum (7 gpm/26.5 lpm in 1" hose and 4 gpm/15 lpm in 3/4" hose) to reduce risk of static electricity. Reduce motor speed to reduce the fluid velocity.

5. Before using, confirm that the pump and any accessories (hose, nozzle, flow meter, etc.) materials of construction are suitable for the material to be pumped and that the maximum temperature is not exceeded.

Veillez lire attentivement ces instructions avant d'utiliser la pompe et l'équipement du moteur. Le fabricant ne sera pas tenu responsable des dommages matériels ou corporels causés par une utilisation inappropriée de l'équipement.

⚠ AVERTISSEMENT: Il est de la responsabilité de l'utilisateur de faire fonctionner la pompe conformément aux règles OSHA (Santé et Sécurité au Travail) relatives à la distribution de liquides. Les conteneurs de pompes doivent être électriquement mis à la terre lors de l'utilisation de liquides inflammables ou combustibles afin d'éviter toute électricité statique.

1. Lors du transfert de liquides inflammables ou combustibles, utilisez uniquement des moteurs électriques ou non électriques (pneumatiques) antidéflagrants sur des tubes de pompe en acier inoxydable dotés d'un dispositif de protection antistatique.

⚠ AVERTISSEMENT: N'utilisez jamais de moteur ouvert, à l'épreuve des éclaboussures, TEFC, alimenté par piles ou non antidéflagrant, ni un tube de pompe en plastique lors du transfert de liquides inflammables ou combustibles.

2. Lors de l'utilisation d'une pompe à tambour (en particulier lors du pompage de liquides inflammables, combustibles ou dangereux), respectez tous les codes électriques et les codes de sécurité.

a) Aux États-Unis : Loi américaine sur la sécurité et la santé au travail (OSHA); le code national de l'électricité (NEC) le plus récent; le code 30 de la NFPA (code d'inflammabilité et de produits combustibles); le code NFPA 77 (électricité statique); le code NFPA 251 (Méthode standard de test d'incendie de la construction de bâtiments); le code NFPA 704 (Identification des risques d'incendie des matériaux) et autres codes et règlements de la NFPA.

b) En dehors des États-Unis : La directive sur les équipements ATEX 2014/34 / EU, le cas échéant, la directive ATEX sur le lieu de travail 99/92 /EC, le cas échéant, ainsi que les précautions des codes des États-Unis énumérés dans la présente et de tous les autres codes, lois et règlements locaux.

3. Le pompage de liquides dangereux, inflammables ou combustibles ne doit être effectué que dans des bâtiments, des pièces ou des zones adaptées à cet usage. (Voir NFPA 30, NFPA 78, NFPA 80, NFPA 251, NFPA 704, autres codes NFPA appropriés, OSHA, les directives des compagnies d'assurance ATEX 99/92 /CE, et autres codes, lois et règlements locaux.)

4. Lors du remplissage de bidons, fûts, etc. avec des liquides combustibles ou inflammables, les conteneurs d'où le liquide est pompé et le conteneur recevant le liquide doivent être reliés et mis à la terre pour éviter toute accumulation éventuelle d'électricité statique et minimiser ainsi les étincelles causées par l'électricité statique (voir NFPA 77). et CLC / TR 60079-32-1 pour des détails spécifiques).

⚠ AVERTISSEMENT: Évitez les éclaboussures. Les éclaboussures peuvent créer de l'électricité statique et sont extrêmement dangereuses. Réduisez la vitesse du moteur pour éviter les éclaboussures.

⚠ AVERTISSEMENT: La vitesse du fluide doit être au maximum de 3 pieds / 0,9 mètre / seconde (7 gpm / 26,5 lpm dans un tuyau de 1"; et 4 gpm / 15 lpm dans un tuyau de 3/4") afin de réduire le risque d'électricité statique. Réduisez la vitesse du moteur afin de réduire ainsi la vitesse du fluide.

5. Avant utilisation, assurez-vous que les matériaux de la pompe et des accessoires (tuyau, ajutage, débitmètre, etc.) sont compatibles avec le fluide et que la température maximale n'est pas dépassée.

INSTALLATION

INSTALACIÓN

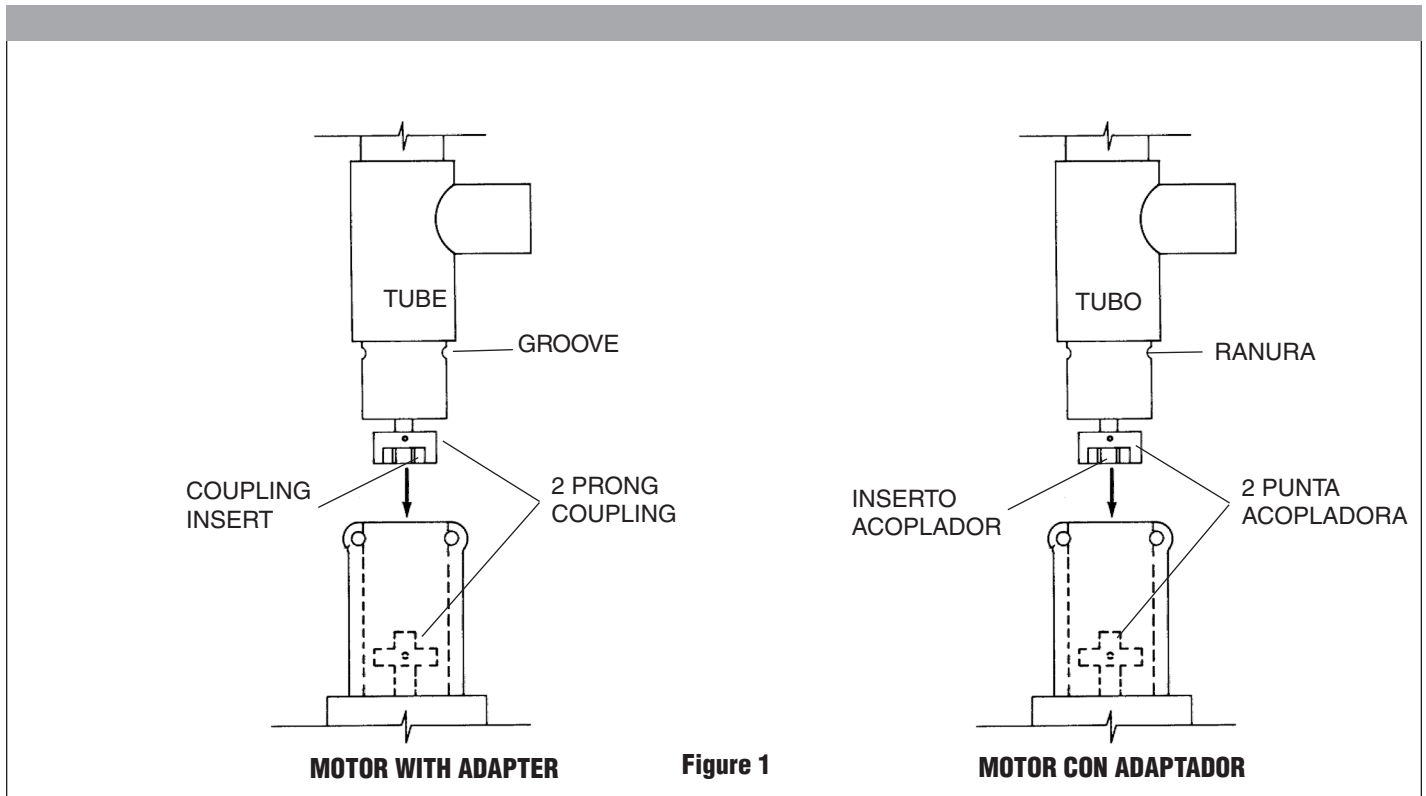

Figure 1

See next page for HVDP motor installation instructions.

Consulte las instrucciones de instalación del motor HVDP en la página siguiente.

Unpack motor from carton and check for shipping damage. Unpack pump/mixer from carton. Check for shipping damage.

If any shipping damage is found, save the packaging and notify the carrier immediately.

1. Ensure motor and pump compatibility. I.E., labeling.
2. Remove 2 socket head screws and nuts or for BT Series motors, loosen set screws.
3. Ensure no obstructions on the coupling of either motor or pump/mixer.
4. Position couplings and coupling insert for proper alignment.
5. Slide pump/mixer down into motor until couplings mate and pump/mixer is seated properly. Refer to Figure 1.
6. Position motor so mounting holes line up with corresponding grooves on pump/mixer. (Note: Always position electric cord away from discharge spout of pump.)
7. Install 2 socket head screws and nuts in mounting holes and tighten securely or for BT Series motors, tighten the set screws.
8. Check to ensure that the motor is secured to the pump/mixer before operating. If not, repeat steps 1-6.

Saque el motor del cartón y revise por daños de embarque. Saque la bomba (o mezclador) del cartón y revise por daños de embarque.

Si se encuentran daños de embarque, póngase en contacto con el suplidor del producto para reemplazarlo o repararlo.

1. Asegúrese de la compatibilidad entre el motor y la bomba. I.E. La etiqueta.
2. Remove 2 tornillos de cabeza de caquillo y tuercas.
3. Asegúrese de que no haya obstrucciones en el acoplador de el motor o la bomba (o mezclador).
4. Coloque el acoplador y el inserto acoplador para una alineación correcta.
5. Deslice la bomba (o mezclador) hacia abajo en el motor hasta que el acoplador y la bomba (o mezclador) esten asentadas correctamente. Vea la Figura 1.
6. Coloque el motor para que los huecos de la estructura y las ranuras correspondientes esten alineadas en la bomba (o mezclador). (Note: Siempre coloque la conexión electrica lejos del caño de descargar de la bomba.)
7. Instale 2 tornillos de cabeza de caquillo y tuercas en los huecos de la estructura y aprietalos seguros.
8. Revise para asegurarse que el motor esté amarrado a la bomba (o mezclador) antes de operar. Si no está, repita los pasos 1-6.

INSTALLATION

INSTALACIÓN

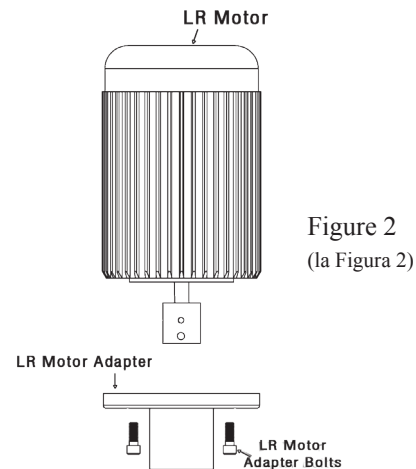
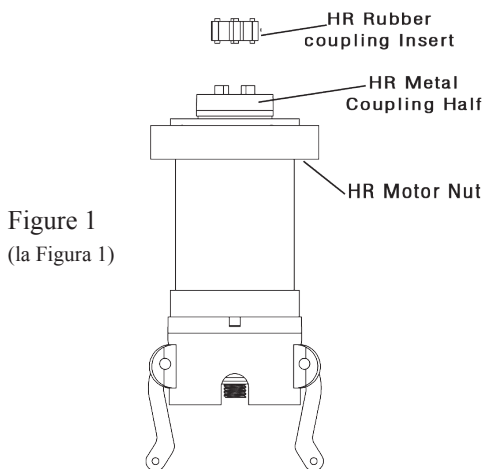

INSTALLATION - HVDP-HR

1. Locate the rubber coupling insert that was separately shipped in a plastic bag (see Figure 1).
2. Install the rubber coupling insert onto the metal coupling half located on top of the HR drive assembly.
3. Find the metal coupling half located inside the HR motor. Align this coupling with rubber insert installed in the second step of these instructions.
4. Slide the HR motor onto the HR drive assembly.
5. Hand tighten the motor nut onto the threaded nose of the HR motor.

REMOVAL - HVDP-HR

1. To remove the HR motor, reverse HR motor installation instructions found in this section.

INSTALLATION - HVDP-LR

1. Check the rotation direction of the LR motor (air and induction motors) before installing the motor onto the pump.
WARNING: Motor rotation must be clockwise when viewed from the fan end of the motor. Rotating the motor in the wrong direction will cause damage to the pump.
2. Remove the motor adapter bolts (see Figure 2) and separate the motor adapter from the motor.
3. Thread the motor adapter onto the LR drive assembly. Hand tighten the motor adapter.
Note: Threads are left-handed. Also, thread lubricant is recommended to ensure smooth, bind free assembly.
4. The LR motor coupling consists of two 5/16" diameter pins welded to a hub. The LR drive assembly coupling has two slots that receive these pins. Align the pins of the motor coupling with the slots on the drive assembly coupling and slide the motor onto the drive assembly.

INSTALACIÓN - HVDP-HR

1. Localice el inserto de acoplamiento de goma que se envió por separado en una bolsa de plástico (consulte la Figura 1).
2. Instale el inserto de acoplamiento de goma en la mitad de acoplamiento de metal ubicada en la parte superior del conjunto del impulsor HR.
3. Encuentre la mitad de acoplamiento de metal ubicada dentro del motor HR. Alinee este acoplamiento con el inserto de goma instalado en el segundo paso de estas instrucciones.
4. Deslice el motor HR en el conjunto del variador HR.
5. Apriete a mano la tuerca del motor en la punta roscada del motor HR.

ELIMINACION - HVDP-HR

1. Para retirar el motor HR, invierta las instrucciones de instalación del motor HR que se encuentran en esta sección.

INSTALACIÓN - HVDP-LR

1. Compruebe la dirección de rotación del motor LR (motores de aire y de inducción) antes de instalar el motor en la bomba.
ADVERTENCIA: La rotación del motor debe ser hacia la derecha cuando se ve desde el extremo del ventilador del motor. Si gira el motor en la dirección incorrecta, se dañará la bomba.
2. Retire los pernos del adaptador del motor (consulte la Figura 2) y separe el adaptador del motor del motor.
3. Enrosque el adaptador del motor en el conjunto del variador LR. Apretar a mano el adaptador del motor.
Nota: Los hilos son zurdos. Además, se recomienda usar lubricante para roscas para garantizar un montaje suave y sin ataduras.

Note: Make sure the coupling is engaged properly and the motor adapter face is flush with the motor face.

5. Rotate the motor until the motor adapter mounting holes align with the threaded holes in the motor face.
6. Install the motor adapter bolts and torque to approximately 7 ft.-lbs. (9.5 N•M)

REMOVAL - HVDP-LR:

1. Remove the LR motor adapter bolts.
2. Remove the LR motor.

4. El acoplamiento del motor LR consiste en dos pasadores de 5/16" de diámetro soldados a un cubo. El acoplamiento del conjunto impulsor LR tiene dos ranuras que reciben estos pasadores. Alinee los pasadores del acoplamiento del motor con las ranuras en el acoplamiento del conjunto del variador y deslice el motor sobre el conjunto del variador.

Nota: Asegúrese de que el acoplamiento esté enganchado correctamente y que la cara del adaptador del motor esté al ras con la cara del motor.

5. Gire el motor hasta que los orificios de montaje del adaptador del motor se alineen con los orificios roscados en la cara del motor.
6. Instale los pernos adaptadores del motor y apriételes a aproximadamente 7 pies-libras. (9.5 N • M)

DESMONTAJE - HVDP-LR:

1. Retire los pernos adaptadores del motor LR.
2. Retire el motor LR.

M3 & M5 MODELS

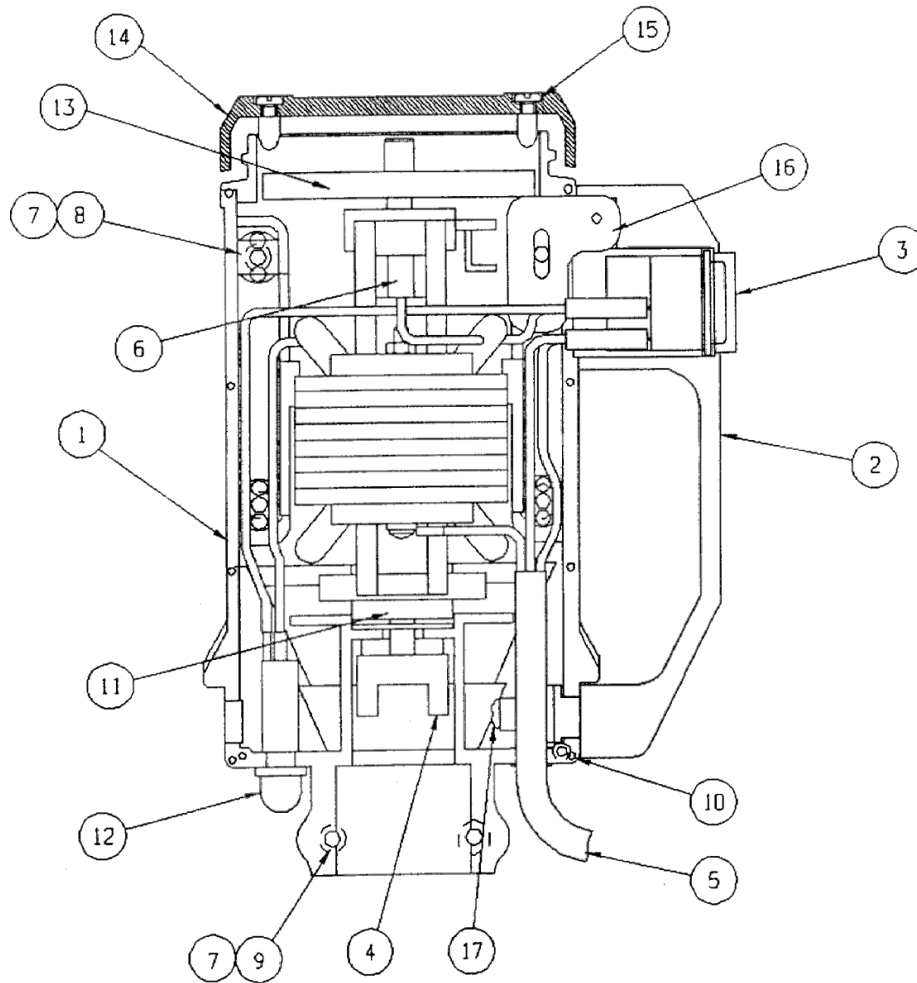

Item	Quantity		Description	Part Number
	M3	M5		
1	1	1	HSG Repair Kit	A101493
2	1	1	Handle	M101668
3	1	1	Switch	A101690
4	1	1	Half Coupling	J100012
5	1	-	Cord Assembly	A102050
5	-	1	Cord Assembly	A102051
6	2	2	Brush	107764
7	6	6	Housing Nut	J100990
8	4	4	Housing Screw	J100022
9	2	2	Socket Head Cap Screw	108392

Item	Quantity		Description	Part Number
	M3	M5		
10	3	3	Screw	J102275
11	1	1	Bearing Kit	A101018
12	1	-	Circuit Breaker w/Cover	A100854
12	-	1	Circuit Breaker w/Cover	A102182
13	1	1	Fan Blade	J101510
14	1	1	Motor Fan Cover	M101710
15	4	4	Cover Screw	J101020
16	1	1	Handle Mounting Block	M101666
17	2	2	Screw	J103715

Note: Motor housing repair kits include motor covers, labels and screws to repair the motor should it be damaged.

M3T (P/N A101128) & M5T (P/N A101132) MODELS

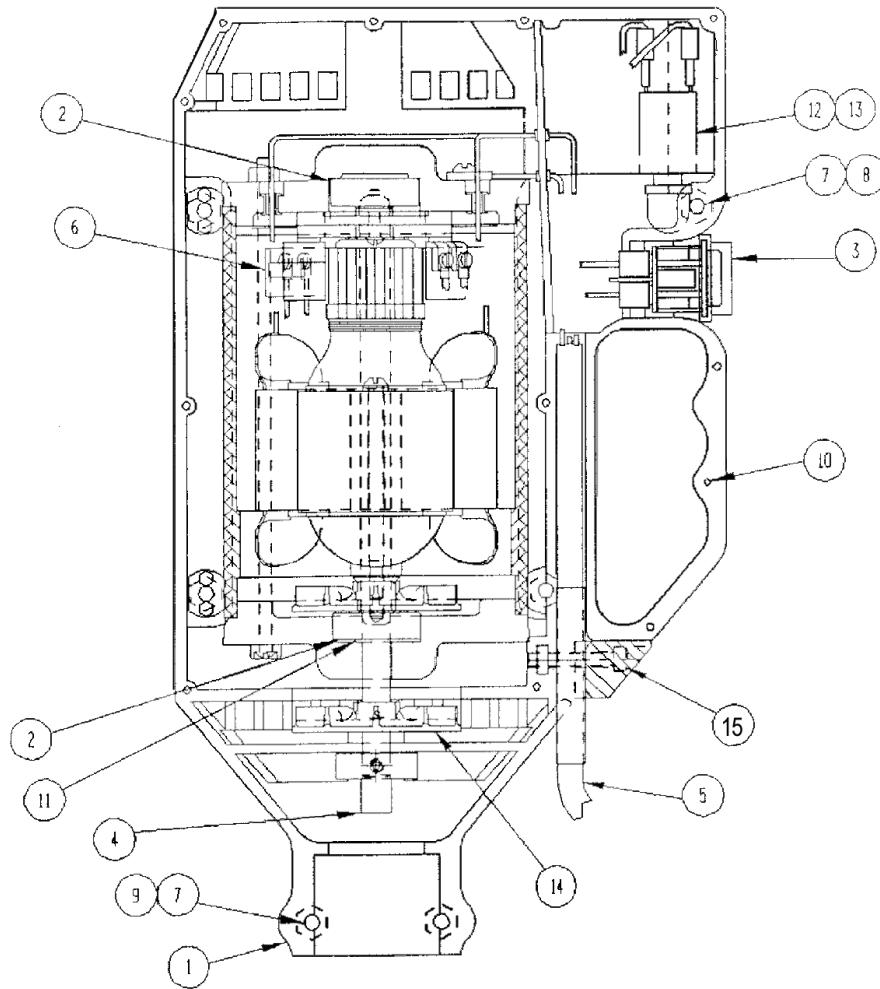

Item	Quantity		Description	Part Number	Item	Quantity		Description	Part Number
	M3T	M5T				M3T	M5T		
1	1	1	HSG Repair Kit	A101416	8	4	4	Socket Head Cap Screw	108392
2	2	2	Ball Bearing	J101069	9	2	2	Mounting Bolt	J101690
3	1	1	Switch	A101690	10	2	2	Screw	J101530
4	1	1	Half Coupling	J100013	11	1	1	Wave Washer	J101126
5	1	-	Cord Assembly	A101738	12	1	-	Circuit Breaker	J103796
5	-	1	Cord Assembly	A101740	12	-	1	Circuit Breaker	J101149
6	2	2	Brush	J101107	13	1	1	Cover	J100789
7	6	6	Housing Nut	J100990	14	1	1	Fan Blade	J101094
					15	2	2	Housing Bolt	J100022

Note: Motor housing repair kits include motor covers, labels and screws to repair the motor should it be damaged.

M7T MODELS

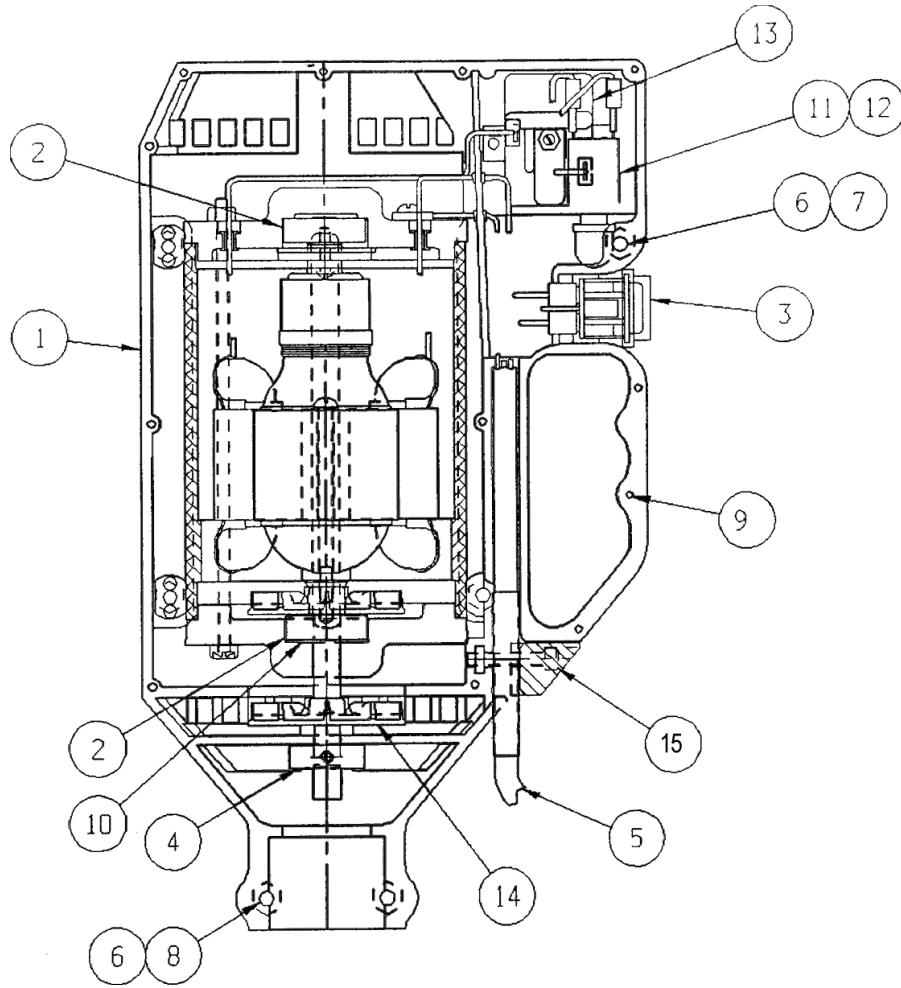

Item	Quantity		Part Number	Item	Quantity		Part Number
	M7T	Description			M7T	Description	
1	1	Housing Repair Kit	A101416	9	2	Screw	J101530
2	2	Ball Bearing	J101069	10	1	Wave Washer	J101126
3	1	Switch	A101690	11	1	Circuit Breaker	J101150
4	1	Half Coupling	J100013	11	-	Circuit Breaker	J101149
5	1	Cord Assembly	A101748	12	1	Cover	J100789
5	-	Cord Assembly	A101751	13	1	Start Relay	J101147
6	6	Housing Nut	J100990	13	-	Start Relay	J101804
7	4	Socket Head Cap Screw	108392	14	1	Fan Blade	A102024
8	2	Mounting Bolt	J101690	15	2	Housing Bolt	J100022

Notes: (1) Motor housing repair kits include motor covers, labels and screws to repair the motor should it be damaged.
 (2) Contact factory for information on M8T.

M58P-M59P MODELS

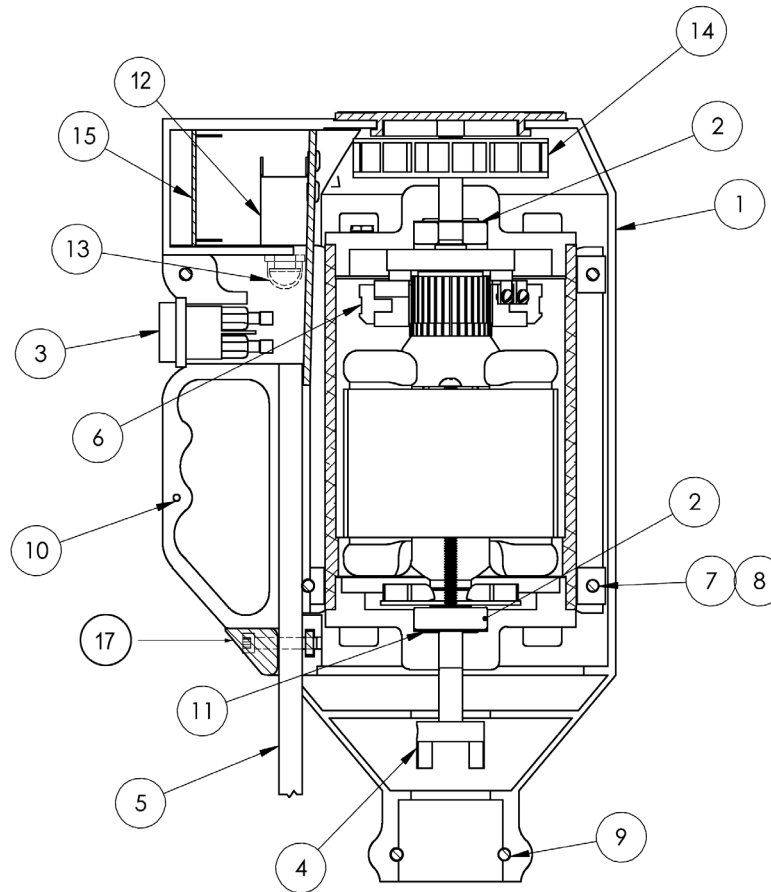

Item	Quantity		Description	Part Number	Item	Quantity		Description	Part Number
	M58P	M59P				M58P	M59P		
1	1	1	Housing Repair Kit	105145	11	1	1	Wave Washer	J101126
2	1	1	Ball Bearing	J101069	12	1	-	Circuit Breaker	J103796
3	1	1	Switch	A101690	12	-	1	Circuit Breaker	J101149
4	1	1	Half Coupling	J100013	13	1	1	Cover	J100789
5	1	-	Cord Assembly	A101738	14	1	1	Fan	105102
5	-	1	Cord Assembly	106732	15	1	1	Speed Control	106086
6	2	2	Brush	J101107	15	1	-	Potentiometer	108176-3
7	6	6	Housing Nut	J100024	15	-	1	Potentiometer	108176-4
8	4	4	Socket Head Cap Screw	108392	*16	1	1	Speed Control Knob & Cover	108414
9	2	2	Mounting Bolt	J101690	17	2	2	Housing Bolt	J100022
10	3	3	Screw	J101530					

*Not shown

Note: Housing Repair Kit includes motor covers, labels, & screws to repair the motor should it be damaged.

M3X, M5X, M7X & M10X MODELS

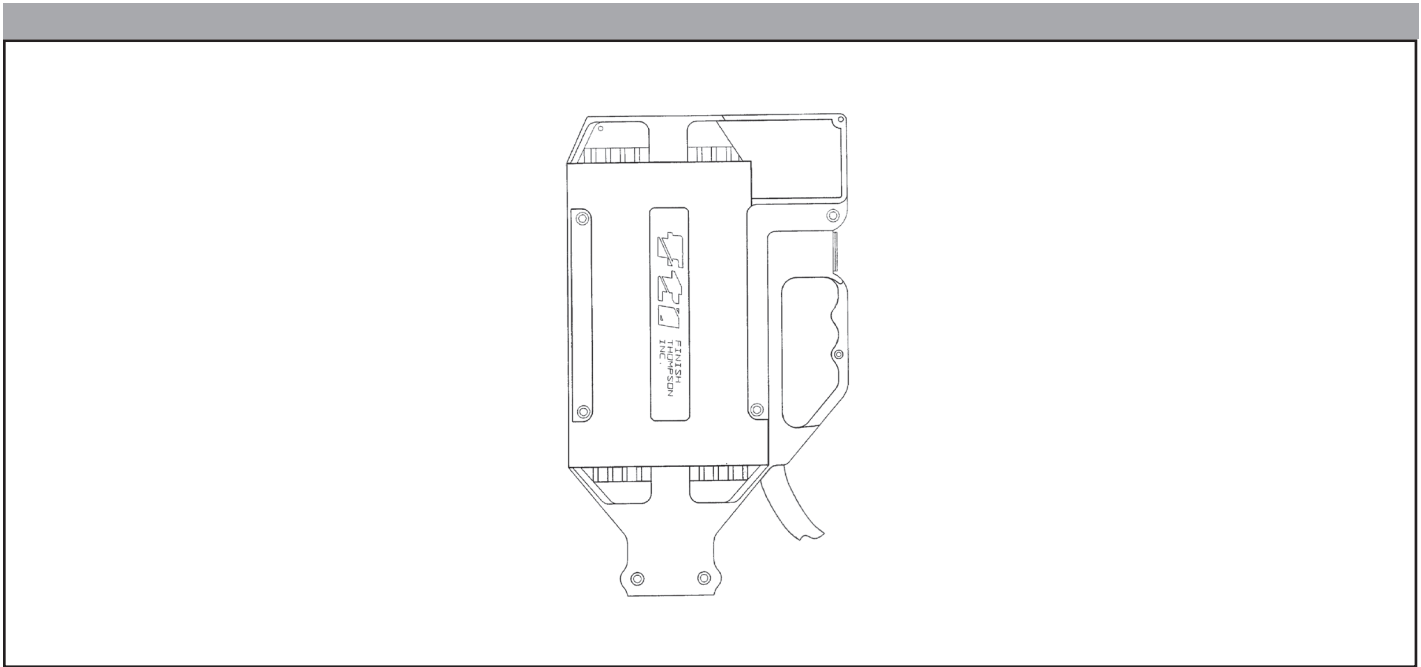

The "X" Series motor housing repair kit number is A101455. Repairs to any item other than the thermoplastic enclosure voids warranty.

El kit de reparación del motor de la Serie "X" es A101455. El hacer reparaciones a cualquier cosa aparte de la cubierta termoplástico anula la garantía.

Note: Motor housing repair kits include motor covers, labels and screws to repair the motor should it be damaged.

BT & HVDP-LR ELECTRIC MODELS

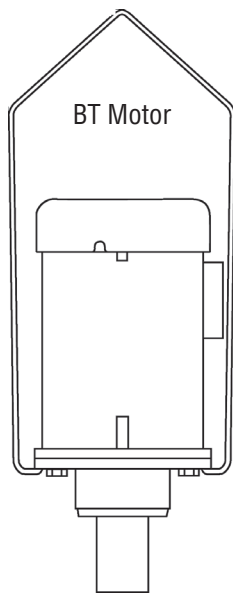

BT TEFC	BT EXP	HVDP TEFC	HVDP EXP
M15	M24X	M60	M67
M16	M25X	M61	M69
M17	M26X	M62	M72
M27	M33X	M63	
M28	M34X	M64	
M29			
M39 (50 Hz)			
M40 (50 Hz)			
M41 (50 Hz)			
M50 (50 Hz)			

Please consult factory for repairs to any of the above listed motors.

Prior to installing the motor verify the motor rotation is in the clockwise direction when viewed from the fan end. Rotating the motor in the wrong direction will cause damage to an HVDP model pump.

M58H-M59H MODELS

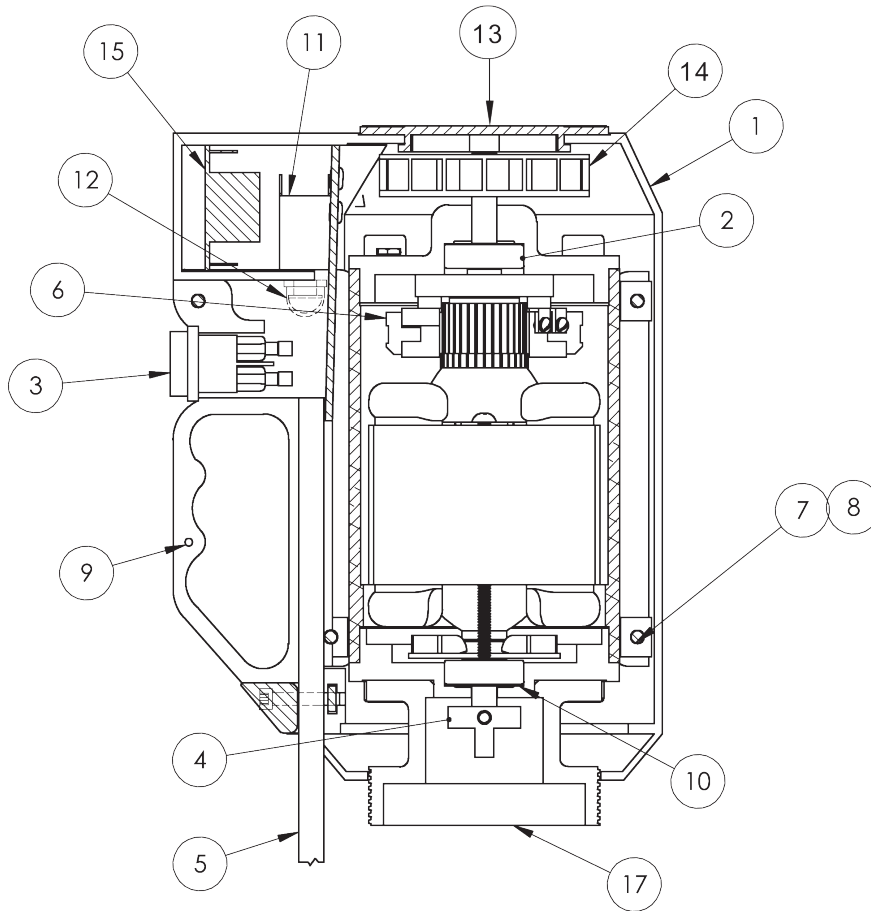

Item	Quantity		Description	Part Number
	M58H	M59H		
1	1	1	Housing Repair Kit	105144
2	2	2	Ball Bearing	J101069
3	1	1	Switch	J101143
4	1	1	Half Coupling	J100013
5	1	-	Cord Assembly	A101738
5	-	1	Cord Assembly	A101740
6	2	2	Brush Set	J101107
7	6	6	Housing Nut	J100990
8	6	6	Housing Bolt	108392
9	3	3	Screw	J101530
10	1	1	Wave Washer	J101126
11	1	-	Circuit Breaker	J103796
12	-	1	Circuit Breaker	J101149
13	1	1	Cover	J100789
14	1	1	Fan	105102
15	1	-	M58 Speed Control	110582-1
15	-	1	M59 Speed Control	110582-2
16	1	1	Speed Control Knob	105063-1
17	1	1	Gearbox Adapter	105133

STATIC PROTECTION KIT

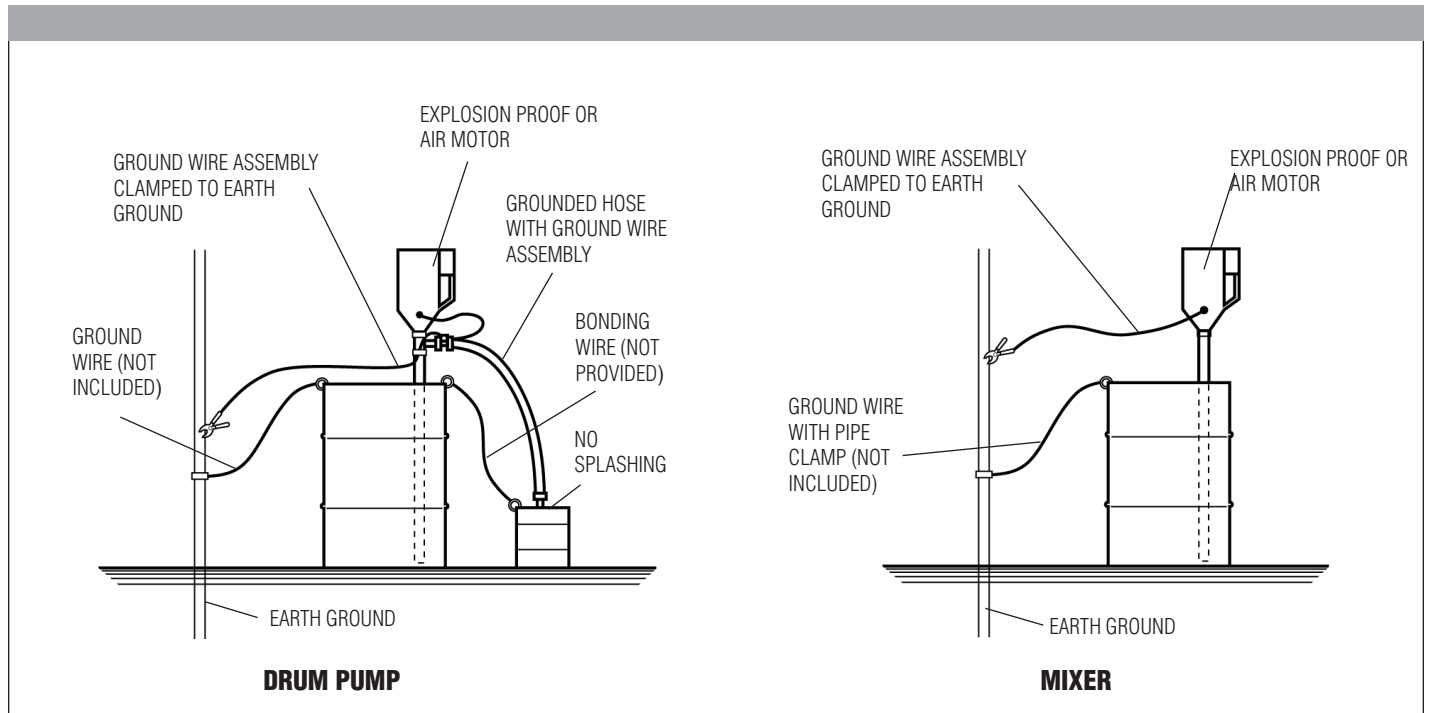

DRUM PUMP INSTALLATION

1. Install the pump and Static Protection Kit as described and shown.
2. Connect ground wire assembly to earth ground using supplied clamp.
3. Connect ground wire between drum and earth ground.
4. Connect ground wire between receiving container and earth ground (or use bonding wire to connect to drum).

⚠ CAUTION - Check electrical continuity of all components before pumping. All should be one (1) ohm or less.

TUBE MIXER INSTALLATION

1. Install the mixer and Static Protection Kit as described and shown.
2. Connect ground wire assembly to earth ground using supplied clamp.
3. Connect ground wire between drum and earth ground.

⚠ CAUTION - Check electrical continuity of all components before pumping. All should be one (1) ohm or less.

OPERATION AND SAFETY GUIDELINES

- Use only metallic pump tubes with explosionproof motors to transfer flammable or combustible liquids.
- Area for use must comply with NFPA 30 guidelines for safe storage and use of flammable and combustible liquids.
- All containers and other equipment must be metal and grounded.
- Follow NFPA 77 guidelines for control of static electricity.
- Avoid splashing. Splash filling can create static electricity and is extremely hazardous.
- Fluid velocity must be 3 feet/second maximum (7 GPM in 1" hose).

EQUIPO DE PROTECCIÓN ESTÁTICO

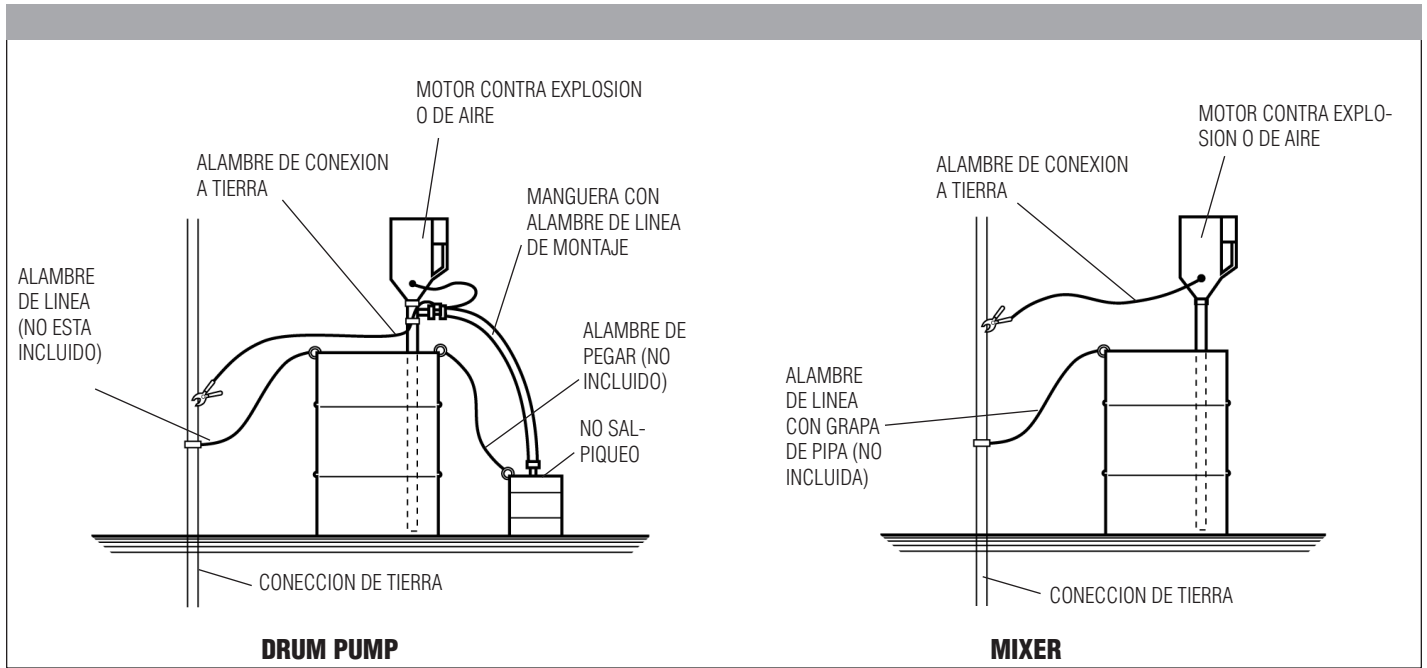

INSTALACIÓN DE LA BOMBA DE MOTOR

1. Instale la bomba y el Equipo de Protección Estático como se describe y se muestra.
2. Conecte el alambre a la conexión de tierra, usando la grapa que se le ha surtido.
3. Conecte el alambre de tierra entre el tambor y la conexión de tierra.
4. Conecte el alambre de tierra entre el recipiente receptor y la conexión de tierra (o use alambre de pegar para conectar al tambor).

! CUIDADO - Revise la continuidad eléctrica de todos los componentes antes de bombear. Todos deben ser un (1) ohm o menos.

INSTALACIÓN DEL MEZCLADOR

1. Instale la mezcladora y el Equipo de Protección Estático como se describe y se muestra.
2. Conecte el alambre a la conexión de tierra, usando la grapa que se le ha surtido.
3. Conecte el alambre de línea entre el tambor y la conexión de tierra.

! CUIDADO - Revise la continuidad eléctrica de todos los componentes antes de bombear. Todos deben ser un (1) ohm o menos.

GUIAS DE OPERACIÓN Y SEGURIDAD

- Use solamente tubos de bomba metálicos con motores contra explosivos para transferir líquidos combustibles o inflamables.
- El lugar de uso debe estar de acuerdo con las normas NFPA 30, para almacenar seguramente líquidos combustibles y inflamables.
- Todo recipiente y otro equipo debe ser de metal y conectado a tierra.
- Siga las guías NFPA 77 para el control de electricidad estática.
- Evite salpiquear. El llenar con salpiqueo puede crear electricidad estática y es extremadamente peligroso.
- La velocidad del fluido debe ser de 3 pies/segundo máximo (7 GPM en manguera de 1").



FINISH THOMPSON INC.

921 Greengarden Road • Erie, PA 16501-1591 U.S.A.
Ph 814-455-4478 • Fax 814-455-8518
Email fti@finishthompson.com • www.finishthompson.com

TECH SERVICE 1-800-888-3743
P/N J102516, Rev. 31, 10/7/2020



Order Online: www.PumpCatalog.com