



4SD 50 Hz

SUBMERSIBLE SEWAGE PUMP

DUAL SEAL WITH SEAL SENSOR PROBE

FEATURES

Impeller: Cast iron, two vane semi-open, non-clog with pump-out vanes for mechanical seal protection. Balanced for smooth operation. Silicon bronze impeller available as an option.

Casing: Heavy duty cast iron, volute type for maximum efficiency. 4" flange conforms to 125 # ANSI standard. Connects to A10-40 or A10-60 guide rail system.

Dual Mechanical Seals: Silicon carbide vs. silicon carbide outer seal and ceramic vs. carbon inner seal, stainless steel metal parts, BUNA-N elastomers. Upper and lower shaft seals are positioned independently and are separated by an oil-filled chamber.

Seal Sensor Probe: Located in oil-filled chamber. If pumpage should begin to leak past lower seal it indicates to pump control panel a fault has occurred. **Requires optional Seal Fail Circuit in the control panel.**

Shaft: 300 series stainless steel keyed design.

Fasteners: 300 series stainless steel.

Capable of running dry without damage to components.

AGENCY LISTINGS



Tested to UL 778 and CSA 22.2 108 Standards
By Canadian Standards Association
File #LR38549

APPLICATIONS

Used in a variety of residential, commercial and industrial applications such as:

- Sewage systems
- Flood and pollution control
- Dewatering/Effluent
- Farms
- Hospitals
- Trailer courts
- Motels

SPECIFICATIONS

Pump:

- Maximum solid size: 3"
- Discharge size: 4", 125 # ANSI flange
- Maximum capacity: 620 GPM
- Maximum total head: 60 feet
- 300 Series stainless steel fasteners
- 20' Power cord
- Standard silicon carbide/silicon carbide outer seal

Motor:

- Maximum ambient temperature: 104° F (40° C) continuous duty, 140° F (60° C) intermittent duty
- Rated for continuous duty when fully submerged
- Insulation: Class F
- 50 Hertz
- Single row ball bearings
- 300 Series stainless steel keyed shaft

Three Phase:

- 1.5 - 5 HP
- 380 volt
- Class 10 overload protection must be provided in control panel

Single Phase:

- 1.5 - 5 HP
- 220 volt

MOTORS

- Fully submerged in oil-filled chamber. High grade turbine oil surrounds motor for more efficient heat dissipation, permanent lubrication of bearings and mechanical seal for complete protection against outside environment.
- Class F insulation
- Designed for Continuous Operation: Pump ratings are within the motor manufacturer's recommended working limits and can be operated continuously without damage when fully submerged.
- Bearings: Upper and lower heavy duty ball bearing construction for precision positioning of parts and to carry thrust loads.
- Power and Control Cables: Severe duty rated, oil and water resistant. Epoxy seal on motor end provides secondary moisture barrier in case of outer jacket damage and to prevent oil wicking. 20 foot standard with optional lengths available.
- O-ring: Assures positive sealing against contaminants and oil leakage.

MODELS AND MOTOR INFORMATION

Order Number	HP	Phase	Volts	RPM	Impeller Dia. (in.)	Impeller Code	Maximum Amps	Locked Rotor Amps	KVA Code	Resistance Start	Resistance Line-Line	Weight (lbs.)				
4SD56F6EA	1½	3	380	1450	5.62	E	3.2	24.2	F	na	9.3	195				
4SD56F6DA					6.25	D	3.9									
4SD56G6BA	7.00				B	5.6										
4SD56H6AA	3				7.25	A	7	30.0					H	na	7.5	205
4SD56J6FA	5				7.69	F	8.1	38.5					E	na	4.8	210
4SD56F9EA	1½	1	220		5.62	E	7.5	32.7	D	2.1	1.2	195				
4SD56F9DA					6.25	D	10.2									
4SD56G9BA	2				7.00	B	13.5									
4SD56H9AA	3				7.25	A	17.9	52.1					A	1.3	0.9	205
4SD56J9FA	5				7.69	F	22									210

NOMENCLATURE DESCRIPTION

1st, 2nd and 3rd Character - Discharge Size and Type

4SD = 4" discharge, 3" solids handling, dual seal with seal fail probe in pump.

4th Character - Mechanical Seals

5 = Silicon carbide/silicon carbide/BUNA - lower seal and carbon/ceramic/BUNA - upper seal (standard)

3 = Silicon carbide/tungsten carbide/BUNA - lower seal and carbon/ceramic/BUNA - upper seal (optional)

5th Character - Cycle/RPM

6 = 50 Hz/1450 RPM

6th Character - Horsepower

F = 1½ HP H = 3 HP
G = 2 HP J = 5 HP

7th Character - Phase/Voltage

6 = three phase, 380 V 9 = single phase, 220 V

8th Character - Impeller Diameter

A = 7.25" E = 5.63"
B = 7.00" F = 7.69"
D = 6.25"

9th Character - Cord Length (Power and Sensor)

A = 20' (standard) F = 50'
D = 30' J = 100'

10th Character - Options

B = Bronze impeller E = Epoxy paint
F = Both epoxy paint and bronze impeller

11th Character - Option

H = Pilot duty thermal sensors

APPLICATION DATA

Maximum Solid Size	3"
Minimum Casing Thickness	5/16"
Casing Corrosion Allowance	1/8"
Maximum Working Pressure	30 PSI
Maximum Submergence	50 feet
Minimum Submergence	Fully submerged for continuous operation 6" below top of motor for intermittent operation
Maximum Environmental Temperature	40°C (104°F) continuous operation 60°C (140°F) intermittent operation

CONSTRUCTION DETAILS

Power Cable - Type	14/4, type STOW: three phase, 460 V
Sensor Cable - Type	16/2, type SJTOW: seal sensor only 18/4, type SJTOW: seal/heat sensor
Motor Cover	Gray Cast Iron - ASTM A48 Class 30
Bearing Housing	Gray Cast Iron - ASTM A48 Class 30
Seal Housing	Gray Cast Iron - ASTM A48 Class 30
Casing	Gray Cast Iron - ASTM A48 Class 30
Impeller	Gray Cast Iron - ASTM A48 or Cast Bronze - ASTM B584 C87600
Motor Shaft	AISI 300 Series Stainless Steel
Motor Design	NEMA 56 Frame, oil filled with Class F Insulation
Motor Overload Protection	Three Phase: require ambient compensated Class 10, quick trip overloads in the control panel.
Motor Seal Fail (Moisture) Detection	Seal fail sensor in an oil-filled seal chamber. Connect to an optional relay in control panel.
Optional Motor Thermal Protection	Normally closed on-winding thermostats open at 275° F (135° C) and close at 112° F (78° C). Require terminal connection in the control panel.
External Hardware	300 Series Stainless Steel
Impeller Type	Semi-open with pump out vanes on back shroud
Oil Capacity - Seal Chamber	1.75 quarts
Oil Capacity - Motor Chamber	1½-5 HP single and three phase: 7 quarts 7½ HP three phase: 6.5 quarts

STANDARD PARTS

Ball Bearing	Upper	1½ - 5 HP single and three phase: single row ball- SKF™ 6204-2Z 7½ HP three phase: single row ball - SKF™ 6204-2Z
	Lower	1½ - 5 HP single and three phase: single row ball - SKF™ 5206-2Z 7½ HP three phase: double row ball - SKF™ 5206-2Z
Mechanical Seals - Standard	Upper	Carbon/Ceramic; Type 21
	Lower	Silicon Carbon/Silicon Carbon; Type 31
Mechanical Seals - Optional Lower		Silicon Carbide/Tungsten Carbide: Type 31
O-Ring - Stuffing Box		BUNA-N, AS 568A-265
O-Ring - Motor Cover		BUNA-N, AS 568A-374

DIMENSIONS

(All dimensions are in inches. Do not use for construction purposes.)

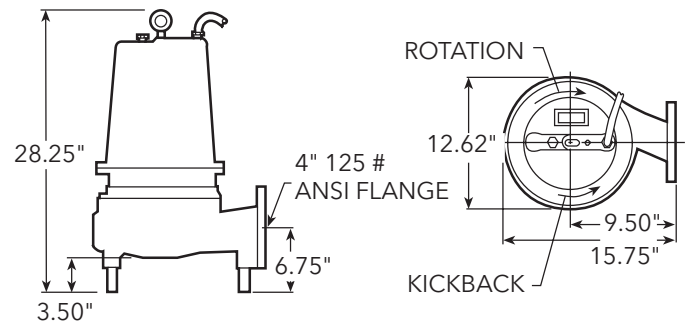

MATERIALS OF CONSTRUCTION

Item No.	Part Name	Material				
		Standard	Optional			
1	Impeller, non-clog	1003	1179			
2	Castings	1003				
3	Shaft-Keyed	300 Series SS				
4	Fasteners	300 Series SS				
5	Ball bearings	Steel				
6	Power cable	STOW, 20 feet			Additional lengths	
	Seal sensor cable					
7	O-ring	BUNA-N				
8	Outer Mech. Seal	Service	Rotary	Stationary	Elastomers	Metal Parts
	OPT	Heavy duty	Silicon Carbide	Tungsten Carbide	BUNA-N	300 Series SS
	STD	Mild abrasives	Silicon Carbide		BUNA-N	300 Series SS
Material Code		Engineering Standard				
1003		Cast iron - ASTM A48 Class 30				
1179		Silicon bronze - ASTM C87600				

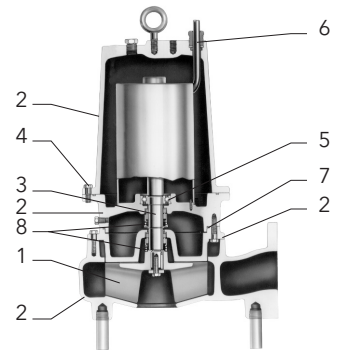

xylem
Let's Solve Water

Xylem, Inc.
2881 East Bayard Street Ext., Suite A
Seneca Falls, NY 13148
Phone: (866) 325-4210
Fax: (888) 322-5877
www.xylem.com/brands/gouldswatertechnology

Goulds is a registered trademark of Goulds Pumps, Inc. and is used under license.
© 2012 Xylem Inc. B4SD50HZ March 2011