

SL1 and SLV pumps

1.5 - 15 hp, 60 Hz

Installation and operating instructions

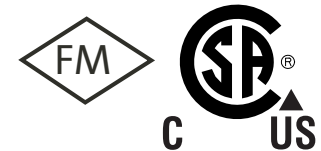

English (US) Installation and operating instructions

Original installation and operating instructions

CONTENTS

	Page
1. LIMITED WARRANTY	2
2. Symbols used in this document	3
3. General description	3
3.1 Product drawing	3
3.2 Control and monitoring	3
3.3 Applications	3
3.4 Operating conditions	4
4. Delivery and handling	5
4.1 Transportation	5
4.2 Storage	5
5. Identification	5
5.1 Nameplate	5
5.2 Type key	6
6. Approvals	7
6.1 Approval standards	7
6.2 Explanation to FM approval	7
7. Safety	7
7.1 Potentially explosive environments	8
8. Installation	8
8.1 Submerged installation on auto-coupling	9
8.2 Free-standing submerged installation on ring stand	10
8.3 Torques for suction and discharge flanges	10
9. Electrical connection	11
9.1 Wiring diagrams	12
9.2 Pump controllers	15
9.3 Thermal switch, Pt1000 and thermistor	15
9.4 WIO sensor (water-in-oil sensor)	16
9.5 Moisture switch	16
9.6 IO 113	16
9.7 Frequency converter operation	17
10. Start-up	18
10.1 General start-up procedure	18
10.2 Operating modes	19
10.3 Direction of rotation	19
11. Maintenance and service	20
11.1 Inspection	20
11.2 Dismantling the pump	20
11.3 Assembling the pump	22
11.4 Oil quantities	23
11.5 Service kits	23
11.6 Contaminated pumps	23
12. Fault finding	24
13. Technical data	26
14. Disposal	27



Warning

Prior to installation, read these installation and operating instructions. Installation and operation must comply with local regulations and accepted codes of good practice.

Warning

The use of this product requires experience with and knowledge of the product.



Persons with reduced physical, sensory or mental capabilities must not use this product, unless they are under supervision or have been instructed in the use of the product by a person responsible for their safety.

Children must not use or play with this product.

1. LIMITED WARRANTY

Products manufactured by GRUNDFOS PUMPS CORPORATION (Grundfos) are warranted to the original user only to be free of defects in material and workmanship for a period of 24 months from date of installation, but not more than 30 months from date of manufacture. Grundfos' liability under this warranty shall be limited to repairing or replacing at Grundfos' option, without charge, F.O.B. Grundfos' factory or authorized service station, any product of Grundfos' manufacture. Grundfos will not be liable for any costs of removal, installation, transportation, or any other charges which may arise in connection with a warranty claim. Products which are sold but not manufactured by Grundfos are subject to the warranty provided by the manufacturer of said products and not by Grundfos' warranty. Grundfos will not be liable for damage or wear to products caused by abnormal operating conditions, accident, abuse, misuse, unauthorized alteration or repair, or if the product was not installed in accordance with Grundfos' printed installation and operating instructions.

To obtain service under this warranty, the defective product must be returned to the distributor or dealer of Grundfos' products from which it was purchased together with proof of purchase and installation date, failure date, and supporting installation data. Unless otherwise provided, the distributor or dealer will contact Grundfos or an authorized service station for instructions. Any defective product to be returned to Grundfos or a service station must be sent freight prepaid; documentation supporting the warranty claim and/or a Return Material Authorization must be included if so instructed.

GRUNDFOS WILL NOT BE LIABLE FOR ANY INCIDENTAL OR CONSEQUENTIAL DAMAGES, LOSSES, OR EXPENSES ARISING FROM INSTALLATION, USE, OR ANY OTHER CAUSES. THERE ARE NO EXPRESS OR IMPLIED WARRANTIES, INCLUDING MERCHANTABILITY OR FITNESS FOR A PARTICULAR PURPOSE, WHICH EXTEND BEYOND THOSE WARRANTIES DESCRIBED OR REFERRED TO ABOVE.

Some jurisdictions do not allow the exclusion or limitation of incidental or consequential damages and some jurisdictions do not allow limit actions on how long implied warranties may last. Therefore, the above limitations or exclusions may not apply to you. This warranty gives you specific legal rights and you may also have other rights which vary from jurisdiction to jurisdiction.

2. Symbols used in this document



Warning
If these safety instructions are not observed, it may result in personal injury.



Warning
If these instructions are not observed, it may lead to electric shock with consequent risk of serious personal injury or death.



Warning
These instructions must be observed for explosion-proof pumps. It is advisable also to follow these instructions for standard pumps.



If these safety instructions are not observed, it may result in malfunction or damage to the equipment.



Notes or instructions that make the job easier and ensure safe operation.

3. General description

This booklet includes instructions for installation, operation and maintenance of Grundfos SL1 and SLV submersible sewage and wastewater pumps with motors of 1.5 to 15 hp (1.1 to 11 kW). Grundfos SL1 and SLV sewage pumps are designed for pumping domestic and industrial sewage and wastewater.

Two types of pumps are available:

- SL1 sewage pumps with S-tube impeller
- SLV sewage pumps with SuperVortex, free-flow impeller.

The pumps can be installed on an auto-coupling system or stand freely on the bottom of a tank.

Grundfos SL1 and SLV pumps are designed with S-tube and SuperVortex impeller, respectively, to ensure reliable and optimum operation.

The booklet also includes specific instructions for the explosion-proof pumps.

3.1 Product drawing

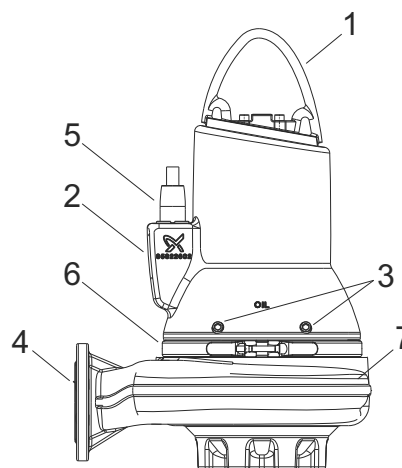

Fig. 1 SL1 pump

Pos.	Description
1	Lifting bracket
2	Nameplate
3	Oil screws
4	Discharge flange
5	Cable plug
6	Clamp
7	Pump housing

3.2 Control and monitoring

The pumps can be controlled via the Grundfos Dedicated Controls, DC or DCD or Simplex (SLC) and Duplex (DLC) controllers. See section [9.2 Pump controllers](#). Pumps with sensor are supplied together with an IO 113. See section [9.6 IO 113](#).

3.3 Applications

SL1 and SLV pumps are designed for pumping these liquids:

- large quantities of drainage and surface water
- domestic wastewater with discharge from toilets
- wastewater with a high content of fibres (SuperVortex impeller)
- municipal and commercial sewage and wastewater.

TMD4 2648 2808

3.4 Operating conditions

The Grundfos SL1 and SLV pumps are suitable for the following operating situations:

- **S1 operation** (continuous operation), the pump must always be covered by the pumped liquid to the top of the motor. See fig. 2.
- **S3 operation** (intermittent operation), the pump must always be covered by the pumped liquid up to the top of the cable entry. See fig. 2.

For further information about S1 and S3 operation, see section [10.2 Operating modes](#).

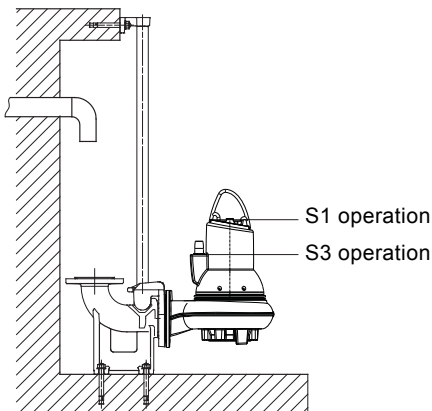

Fig. 2 Stop levels

pH value

SL1 and SLV pumps in permanent installations can be used for pumping liquids with the following pH values:

Pump type	Material variant	Material	pH value
SL1/SLV	Standard	Cast iron impeller and pump housing	6.5 to 14 ¹⁾
SLV	Q	Stainless steel impeller and cast iron pump housing	6 to 14 ¹⁾

¹⁾ For fluctuating pH values, the range is pH 4 to 14.

Liquid temperature

32 °F to +104 °F (0 °C to + 40 °C).

For short periods (maximum 3 minutes) a temperature of up to +140 °F (+60 °C) is permissible (non-FM versions only).



Warning

Explosion-proof pumps must never pump liquids of a temperature higher than +104 °F (+40 °C).

Ambient temperature



Warning

For explosion-proof pumps, the ambient temperature on the installation site must be in the range from -4 °F to +104 °F (-20 °C to +40 °C).

For explosion-proof pumps with WIO sensor, the ambient temperature at the installation site must be in the range from 32 °F to +104 °F (0 °C to +40 °C).

For non-explosion proof pumps, the ambient temperature may exceed +104 °F (+40 °C) for a short period (max. 3 minutes).

Density and viscosity of pumped liquid

When pumping liquids with a density and/or a kinematic viscosity higher than that of water, use motors with correspondingly higher outputs.

Flow velocity

It is advisable to keep a minimum flow velocity to avoid sedimentations in the piping system. Recommended flow velocities:

- in vertical pipes: 2.3 ft/s (0.7 m/s)
- in horizontal pipes: 3.3 ft/s (1.0 m/s)

Free spherical passage

From 2" to 4" (50 to 100 mm), depending on pump size.

Operating mode

Maximum 20 starts per hour.

TM04 2649 2808

4. Delivery and handling

The pump may be transported and stored in a vertical or horizontal position. Make sure that it cannot roll or fall over.

4.1 Transportation

All lifting equipment must be rated for the purpose and checked for damage before any attempts to lift the pump. The lifting equipment rating must under no circumstances be exceeded. The pump weight is stated on the pump nameplate.



Warning

Always lift the pump by its lifting bracket or by means of a fork-lift truck if the pump is fixed on a pallet. Never lift the pump by means of the motor cable or the hose/pipe.

4.2 Storage

During long periods of storage, the pump must be protected against moisture and heat.

Storage temperature: -22 °F to +140 °F (-30 °C to +60 °C)



Warning

If the pumps are stored for more than one year or it takes a long time before it is put into operation after the installation, the impeller must be turned at least once a month.

If the pump has been in use, the oil should be changed before storage.

After a long period of storage, the pump should be inspected before it is put into operation. Make sure that the impeller can rotate freely. Pay special attention to the condition of the shaft seal, O-rings, oil and the cable entry.

5. Identification

5.1 Nameplate

The nameplate states the operating data and approvals applying to the pump. The nameplate is fitted to the side of the stator housing close to the cable entry.

Fix the extra nameplate supplied with the pump to the cable end in the controller.

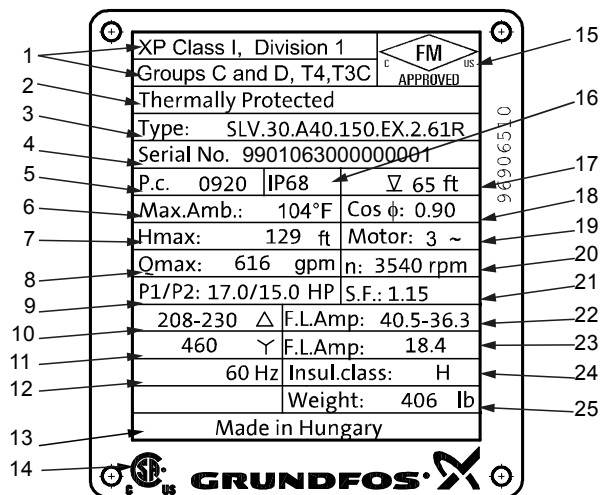

Fig. 3 Nameplate

Pos.	Description
1	FM marking
2	Thermally protected
3	Type designation
4	Serial number
5	Production code (year/week)
6	Maximum ambient temperature
7	Maximum head
8	Maximum flow rate
9	Rated input/output power
10	Rated voltage, D
11	Rated voltage, Y
12	Frequency
13	Country of production
14	CSA mark
15	FM mark
16	Enclosure class to IEC
17	Maximum installation depth
18	Power factor
19	Number of phases
20	Rated speed
21	Service factor
22	Full load current, D
23	Full load current, Y
24	Insulation class
25	Weight without cable

TM04 4187 0909

5.2 Type key

The pump can be identified by means of the type designation stated on the pump nameplate. See section [5.1 Nameplate](#).

Code	Example	SL	1	30.	A30.	55.	A.	Ex.	4.	6.	1H	A.	Q.
	Pump type:												
SL	Grundfos wastewater pump												
	Impeller type:												
1	S-tube impeller												
V	SuperVortex (free-flow) impeller												
	Free spherical passage: Code number from type key/10 [inches]:												
20	2" (50 mm)												
25	2.5" (65 mm)												
30	3" (80 mm)												
40	4" (100 mm)												
	Pump discharge (discharge port in inches):												
A25	ANSI 2.5" (DN 65)												
A30	ANSI 3" (DN 80)												
A40	ANSI 4" (DN 100)												
A60	ANSI 6" (DN 150)												
	Motor power, P2: Code number from type key/10 [hp]												
	1.5 - 15 hp												
55	5.5 hp = 4.0 kW												
	Sensor version:												
Blank	Standard												
A	Sensor version												
	Pump version:												
Blank	Non-explosion-proof pump (standard)												
Ex	Explosion-proof pump												
	Number of poles:												
2	2-pole												
4	4-pole												
	Frequency:												
6	60 Hz												
	Voltage and starting method:												
0J	3 x 208-230 V Δ direct-on-line starting												
1H	3 x 460 V Δ star-delta starting												
0L	3 x 575 V Δ direct-on-line starting												
1L	3 x 575 V Δ star-delta starting												
1R	3 x 230 V Δ / 460 V Ydirect-on-line starting												
	Product generation:												
Blank	1st generation												
A	2nd generation												
B	3rd generation												
C	4rd generation												
	Pump materials:												
Blank	Cast iron impeller, pump housing and motor housing												
Q	Stainless steel impeller (according to 316/351 CF8M), cast iron pump housing and motor housing												
	Customization:												
Blank	Pump in standard range												
Z	Custom-built pump												

6. Approvals

The SL1 and SLV pumps have been approved by CSA and FM, and the explosion-proof versions hold an FM type examination certificate no.: 3035318.

6.1 Approval standards

These pumps have been approved by CSA and FM according to UL778, C22.2 no. 108 and FM 3600, FM 3615 and FM 3650.

6.2 Explanation to FM approval

The SL1 and SLV pumps have the following explosion protection classification: Class I, Division 1, Groups C and D, T4, T3, IP68.

Standards	Code	Description
	Class I	= Explosive atmosphere is caused by gas or vapours.
	Division 1	= Area classification
FM 3600 FM 3615 FM 3650	Groups C and D	= Classification of gases
	T4/T3	= Maximum surface temperature is 275 °F (135 °C) and 392 °F (200 °C)
	IP68	= Enclosure class according to IEC 60529.

7. Safety



Warning

Pump installation in tanks must be carried out by specially trained persons.

Work in or near tanks must be carried out according to local regulations.



Warning

Persons must not enter the installation area when the atmosphere is explosive.



Warning

It must be possible to lock the mains switch in position 0. Type and requirements as specified in National Electrical Code and all local codes.

For safety reasons, all work in tanks must be supervised by a person outside the pump tank.

Note

It is advisable to make all maintenance and service jobs when the pump is placed outside the tank.

Tanks for submersible sewage and wastewater pumps may contain sewage or wastewater with toxic and/or disease-causing substances. Therefore, all persons involved must wear appropriate personal protective equipment and clothing, and all work on and near the pump must be carried out under strict observance of the hygiene regulations in force.



Warning

Make sure that the lifting bracket is tightened before attempting to lift the pump. Tighten if necessary. Carelessness during lifting or transportation may cause injury to personnel or damage to the pump.

The following warnings and notes also appear in a label (delivered with the pump). Place the label near the controller.



Warning

Risk of electric shock. Do not remove cable and strain relief. Do not connect conduit to pump.



Warning

Risk of electric shock
This pump has not been approved for use in swimming pools or marine areas.



Warning

To reduce risk of electric shock, see installation and operating instructions for guidance in proper installation.



Warning

To reduce risk of electric shock, install only on a circuit protected by a ground-fault circuit interrupter (GFCI).

Note

Acceptable for indoor and outdoor use.

Note

Submersible pump.

Caution

Provide suitable motor protection based on the electrical ratings.

Caution

Enclosure type 3.

Caution

This pump has been tested with water only.

Caution

Use with approved motor-protective circuit breaker matching motor input in full-load amperes with overload element(s) selected or adjusted in accordance with control instructions.

7.1 Potentially explosive environments

Use explosion-proof pumps for applications in potentially explosive environments. See section [6.2 Explanation to FM approval](#).



Warning

SL1 and SLV pumps must under no circumstances be used to pump explosive, flammable or combustible liquids.



Warning

The classification of the installation site must be approved by the local fire-fighting authorities in each individual case.



Special conditions for safe use of SL1 and SLV explosion-proof pumps:

1. Make sure the moisture switches and thermal switches are connected in the same circuit but have separate alarm outputs (motor stop) in case of high humidity or high temperature in the motor.
2. Bolts used for replacement must be class A2-70 or better according to EN/ISO 3506-1.
3. Contact the manufacturer for information on the dimensions of the flameproof joints.
4. The level of pumped liquid must be controlled by two level switches connected to the motor control circuit. The minimum level depends on the installation type and is specified in these installation and operating instructions.
5. Make sure the permanently attached cable is suitably mechanically protected and terminated in a suitable terminal board placed outside the potentially explosive area.
6. The sewage pumps have an ambient temperature range of -4 °F to +104 °F (-20 °C to +40 °C) and a maximum process temperature of +104 °F (+40 °C). The minimum ambient temperature for a pump with a water-in-oil sensor is 32 °F (0 °C).
7. The thermal protection in the stator windings has a nominal switch temperature of 302 °F (150 °C) and must guarantee the disconnection of the power supply; the power supply must be reset manually.
8. The control unit must protect the WIO sensor against short circuit current of the supply to which it is connected. The maximum current from the control unit must be limited to 350 mA.

8. Installation



Warning

During installation, always support the pump by means of lifting chains or place it in horizontal position to secure stability.



Caution

Prior to installation, make sure the tank bottom is even.



Warning

Before beginning the installation, switch off the power supply and lock the mains switch in position 0. Any external voltage connected to the pump must be switched off before working on the pump.

Before beginning installation procedures, carry out these checks:

- Does the pump correspond to order?
- Is the pump suitable for the supply voltage and frequency available at the installation site?
- Are accessories and other equipment undamaged?



Note

Further details concerning accessories can be found in the data booklet SL1, SLV pumps on www.grundfos.us.

Fix the extra nameplate supplied with the pump to the cable end in the controller.

All safety regulations must be observed at the installation site, e.g. the use of blowers for fresh-air supply to the tank.

Prior to installation, check the oil level in the oil chamber.

See section [11. Maintenance and service](#).



Warning

Do not put your hands or any tool into the pump suction or discharge port after the pump has been connected to the power supply, unless the pump has been switched off by removing the fuses or switching off the mains switch. It must be ensured that the power supply cannot be accidentally switched on.



Caution

We recommend that you always use Grundfos accessories to avoid malfunctions due to incorrect installation.



Warning

Only use the lifting bracket for lifting the pump. Do not use it to hold the pump when in operation.

Installation types

The SL1 and SLV pumps are designed for two installation types:

- submerged installation on auto-coupling
- free-standing submerged installation on ring stand.

8.1 Submerged installation on auto-coupling

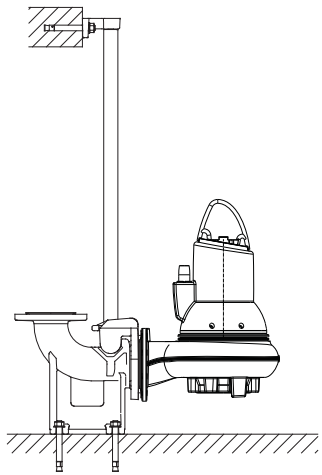

TM04 2650 2808

Fig. 4 Submerged installation on auto coupling

Pumps for permanent installation can be installed on a stationary auto-coupling guide rail system. The auto-coupling system facilitates maintenance and service as the pump can easily be lifted out of the tank. See fig. 4.



Warning
Before beginning installation procedures, make sure that the atmosphere in the tank is not potentially explosive.

Caution

Make sure that the pipework is installed without the use of undue force. No loads from the pipework weight must be carried by the pump. We recommend the use of loose flanges to ease the installation and to avoid pipe tension at flanges and bolts.

Caution

Do not use elastic elements or bellows in the pipework; these elements should never be used as a means to align the pipework.

Proceed as follows:

1. Drill mounting holes for the guide rail bracket on the inside of the tank and fasten the guide rail bracket provisionally with two screws.
2. Place the auto-coupling base unit on the bottom of the tank. Use a plumb line to establish the correct positioning. Fasten the auto-coupling with expansion bolts. If the bottom of the tank is uneven, the auto-coupling base unit must be supported so that it is level when being fastened.
3. Assemble the discharge pipe in accordance with the generally accepted procedures and without exposing the pipe to distortion or tension.
4. Place the guide rails on the auto-coupling base unit and adjust the length of the rails accurately to the guide rail bracket at the top of the tank.
5. Unscrew the provisionally fastened guide rail bracket. Insert the upper guide rail bracket into the guide rails. Fasten the guide rail bracket on the inside of the tank.

Note

The guide rails must not have any axial play as this would cause noise during pump operation.

6. Clean out debris from the tank before lowering the pump into the tank.
7. Fit the guide claw to the discharge port of the pump.
8. Slide the guide claw of the pump between the guide rails and lower the pump into the tank by means of a chain secured to the lifting bracket of the pump. When the pump reaches the auto-coupling base unit, the pump will automatically connect tightly.
9. Hang up the end of the chain on a suitable hook at the top of the tank and in such a way that the chain cannot come into contact with the pump housing.
10. Adjust the length of the motor cable by coiling it up on a relief fitting to ensure that the cable is not damaged during operation. Fasten the relief fitting to a suitable hook at the top of the tank. Make sure that the cables are not sharply bent or pinched.
11. Connect the motor cable.

Note

The free end of the cable must not be submerged, as water may penetrate into the cable.

8.1.1 Size of anchor bolts in foundation

Auto-coupling base unit	Anchor bolts	Pull-out strength for a single bolt [kipf (kN)]
A30/A40 (DN 80/100)	4 x M16	0.45 (2.0)
A40 (DN 100)	4 x M16	0.56 (2.5)
A60 (DN 150)	4 x M16	0.56 (2.5)
A80 (DN 200)	4 x M24	0.45 (2.0)
A100 (DN 250)	4 x M24	0.56 (2.5)
A120 (DN 300)	4 x M24	0.67 (3.0)

Note

The strengths given above do not include safety factor. The required safety factor depends on the materials and method used for anchoring.

8.2 Free-standing submerged installation on ring stand

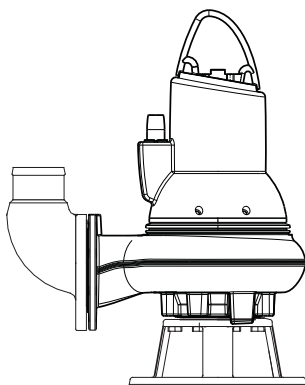

TM04 2651 2808

Fig. 5 Free-standing submerged installation on a ring stand

Pumps for free-standing submerged installation can stand freely on the bottom of the tank. The pump must be installed on a ring stand. See fig. 5.

The ring stand is available as an accessory.

In order to facilitate service on the pump, fit a flexible union or coupling to the elbow on the discharge port for easy separation.

If a hose is used, make sure that the hose does not buckle and that the inside diameter of the hose matches that of the pump discharge port.

If a rigid pipe is used, fit the union or coupling, non-return valve and isolating valve in the order mentioned, when viewed from the pump.

If the pump is installed in muddy conditions or on uneven ground, support the pump on bricks or a similar support.

Proceed as follows:

1. Fit a 90 ° elbow to the pump discharge port and connect the discharge pipe/hose.
2. Lower the pump into the liquid by means of a chain secured to the lifting bracket of the pump. We recommend that you place the pump on a plane, solid foundation. Make sure that the pump is hanging from the chain and **not** the cable. Make sure that the pump is standing securely.
3. Hang up the end of the chain on a suitable hook at the top of the tank and in such a way that the chain cannot come into contact with the pump housing.
4. Adjust the length of the motor cable by coiling it up on a relief fitting to ensure that the cable is not damaged during operation. Fasten the relief fitting to a suitable hook at the top of the tank. Make sure that the cable is not sharply bent or pinched.
5. Connect the motor cable.

Note

The free end of the cable must not be submerged, as water may penetrate into the cable.

8.3 Torques for suction and discharge flanges

Grade 4.6 (5) galvanized steel screws and nuts

	Nominal diameter [inch]	Pitch circle diameter [inch]	Screws	Specified tightening torques rounded off by +/- 5 [ft.lbs (Nm)]	
				Slightly oiled	Well lubricated
Suction	2 1/2	5 1/2	4 x M16	50 (70)	45 (60)
	3	6	8 x M16	50 (70)	45 (60)
	4	7 1/2	8 x M16	50 (70)	45 (60)
	6	9 1/2	8 x M20	100 (140)	90 (120)
Discharge	2 1/2	5 1/2	4 x 5/8" UNC	50 (70)	45 (60)
	3	6	8 x 5/8" UNC	50 (70)	45 (60)
	4	7 1/2	8 x 5/8" UNC	50 (70)	45 (60)
	6	9 1/2	8 x 3/4" UNC	90 (120)	80 (100)

Grade A2.50 (AISI 304) steel screws and nuts

	Nominal diameter [inch]	Pitch circle diameter [inch]	Screws	Specified tightening torques rounded off by +/- 5 [ft.lbs (Nm)]	
				Slightly oiled	Well lubricated
Suction	2 1/2	5 1/2	4 x M16	-	45 (60)
	3	6	8 x M16	-	45(60)
	4	7 1/2	8 x M16	-	45 (60)
	6	9 1/2	8 x M20	-	90 (120)
Discharge	2 1/2	5 1/2	4 x 5/8" UNC	-	45 (60)
	3	6	8 x 5/8" UNC	-	45(60)
	4	7 1/2	8 x 5/8" UNC	-	45(60)
	6	9 1/2	8 x 3/4" UNC	-	80 (100)

Caution

The gasket must be a full face, reinforced paper gasket like Klingsil C4300. If softer gasket material is used, torques must be reconsidered.

9. Electrical connection



Warning

The pump must not run dry.

An additional level switch must be installed to ensure that the pump is stopped in case the stop level switch is not operating.



Warning

Connect the pump to an external mains switch which ensures all-pole disconnection with a contact separation according to National Electrical Code and all local codes.

It must be possible to lock the mains switch in position 0. Type and requirements as specified in National Electrical Code and all local codes.

The electrical connection must be carried out in accordance with local regulations.



Warning

The pumps must be connected to a controller with a motor protection relay with IEC trip class 10 or 15 or nema equivalent.



Warning

Power supply for motor protection circuit must be low voltage, Class 2.

See motor protection wiring diagram in section [9.1 Wiring diagrams](#).



Warning

Pumps for hazardous locations must be connected to a controller with a motor protection relay with IEC trip class 10.

See fig. [12](#).



Warning

Do not install Grundfos pump controllers, Ex barriers and the free end of the power cable in potentially explosive environments.

The classification of the installation site must be approved by the local fire-fighting authorities in each individual case.

On explosion-proof pumps, make sure that an external earth lead is connected to the external earth terminal on the pump using a secure cable clamp. Clean the surface of the external earth connection and mount the cable clamp.

The earth lead must be minimum AWG 12 type RHH, RHW, RHW-2 or similar, rated for 600 V and min. 194 °F (90 °C), yellow/green.

Make sure that the earth connection is protected from corrosion.

Make sure that all protective equipment has been connected correctly.

Float switches used in potentially explosive environments must be approved for this application. They must be connected to the Grundfos Dedicated Controls, DC/DCD or the SLC/DLC controllers, via an intrinsically safe barrier to ensure a safe circuit.



Warning

If the supply cable is damaged, it must be replaced by the manufacturer, its service agent or similarly qualified persons.

Caution

Set the motor-protective circuit breaker to the rated current of the pump +15 % Service factor. The rated current is stated on the pump nameplate.

Caution

If the pump has an FM mark on the nameplate, make sure that the pump is connected in accordance with the instructions given in this booklet.

The mains supply voltage and frequency are marked on the pump nameplate. The voltage tolerance must be within - 10 %/+ 10 % of the rated voltage. Make sure that the motor is suitable for the power supply available at the installation site.

Pumps without sensor must be connected to one of these two controller types:

- a Grundfos DC, DCD pump controller
- a Simplex (SLC) or Duplex (DLC) pump controller.

Pumps with sensor must be connected to a Grundfos IO 113 and the following controller type is recommended:

- a Grundfos DC, DCD pump controller.



Warning

Before installation and the first start-up of the pump, check the condition of the cable visually to avoid short circuits.

Pumps with WIO sensor

For safe installation and operation of pumps equipped with a WIO sensor, we recommend to install an RC filter between the power contactor and the pump.

Caution

If an RC filter is installed to avoid any kind of transients in the installation, the RC filter must be installed between the power contactor and the pump.

Please note that the following aspects may cause problems in case of transients in the power supply system:

- Motor power:
 - The bigger the motor, the higher the transients.
- Length of motor cable:
 - Where power and signal conductors are running in parallel close to each other, the risk of transients causing interference between power and signal conductors will increase with the length of the cable.
- Switchboard layout:
 - Power and signal conductors must be physically separated as much as possible. Close installation can cause interference in case of transients.
- Supply network "stiffness":
 - If a transformer station is located close to the installation, the supply network may be "stiff" and transient levels will be higher.

If combinations of the above aspects are present, it may be necessary to install RC filters for pumps with WIO sensors to protect against transients.

Transients can be completely eliminated if soft starters are used. But be aware that soft starters and variable speed drives have other EMC-related issues that must be taken into consideration.

For more information, see section [9.7 Frequency converter operation](#).

9.1 Wiring diagrams

The pumps are supplied via either a 7-wire cable or a 10-wire cable. See fig. 6 for wiring diagrams for 7-wire cable connection or figs. 7, 8 and 9 for wiring diagrams for 10-wire cable connection. For further information, see the installation and operating instructions for the selected pump controller.

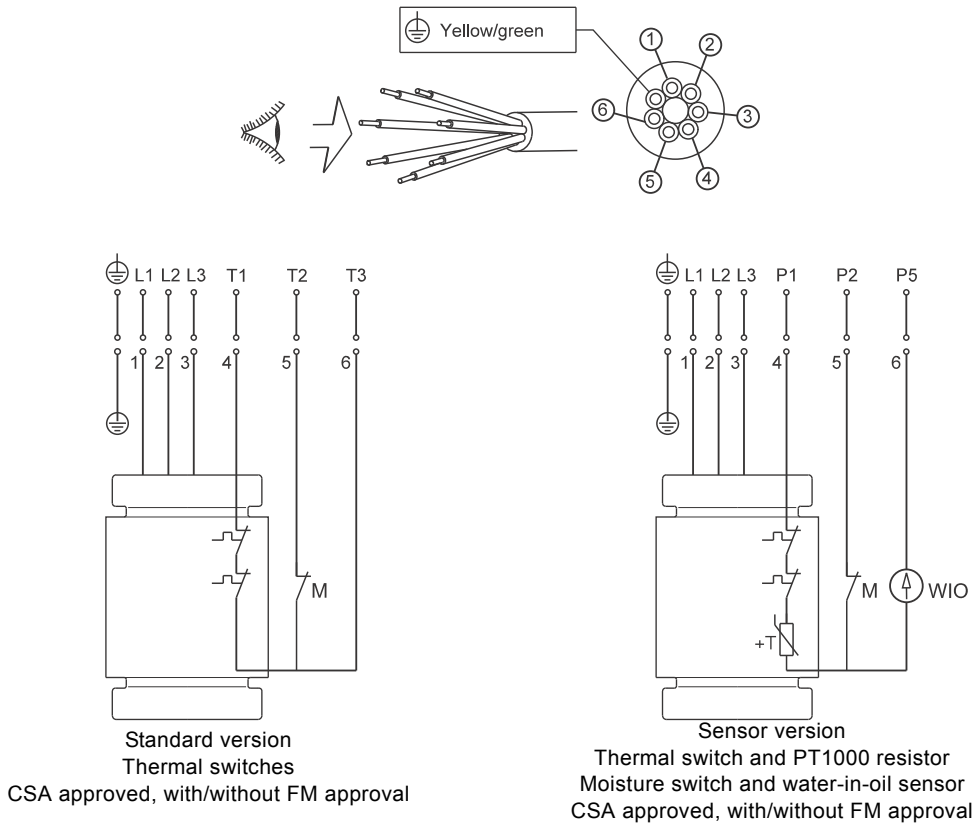

TM04 6689 0314

Fig. 6 Wiring diagram, 7-wire cable, DOL

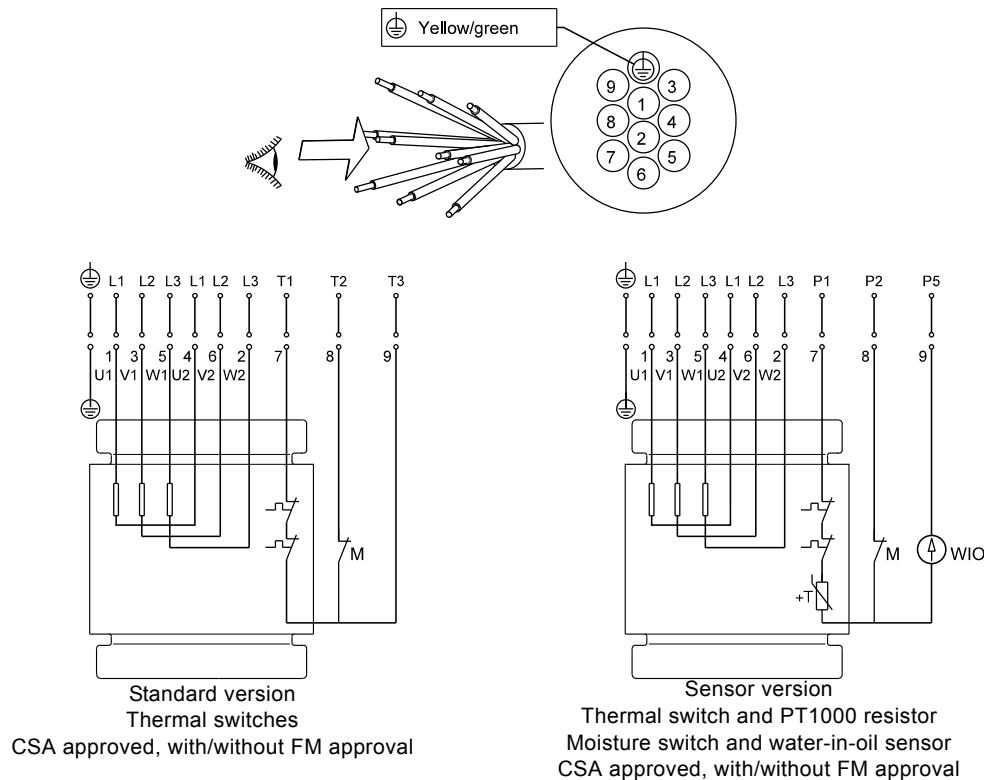

TM04 6690 0314

Fig. 7 Wiring diagram, 10-wire cable, Star/Delta (Y/D)

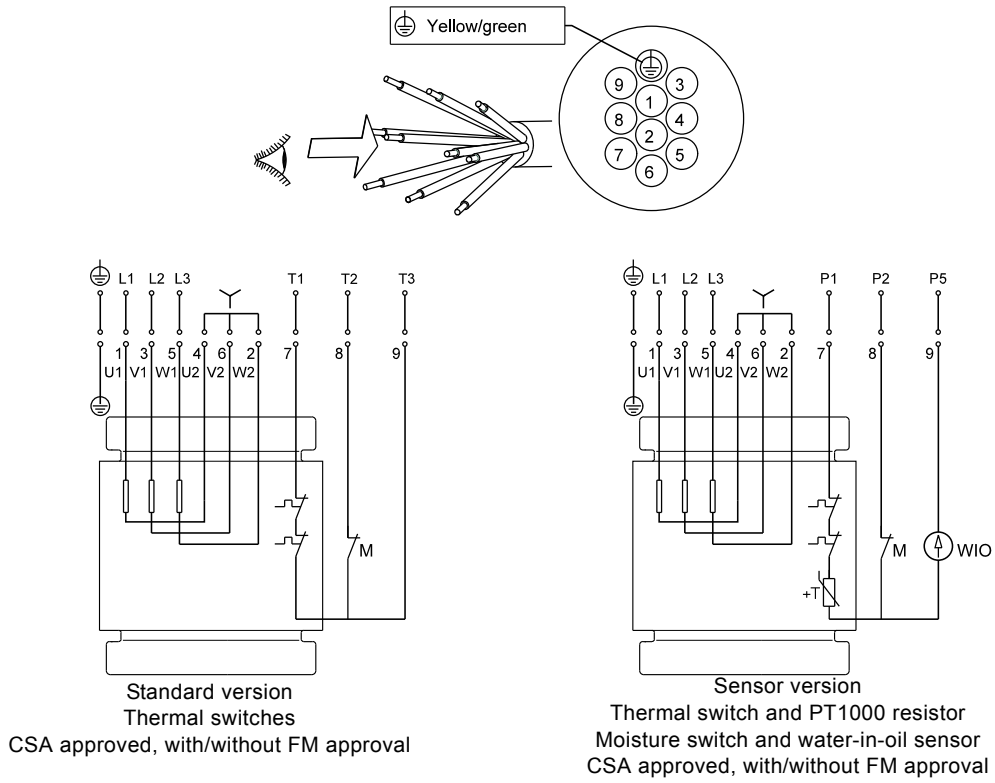

TM04 6691 0314

Fig. 8 Wiring diagram, 10-wire cable, Star connected (Y)

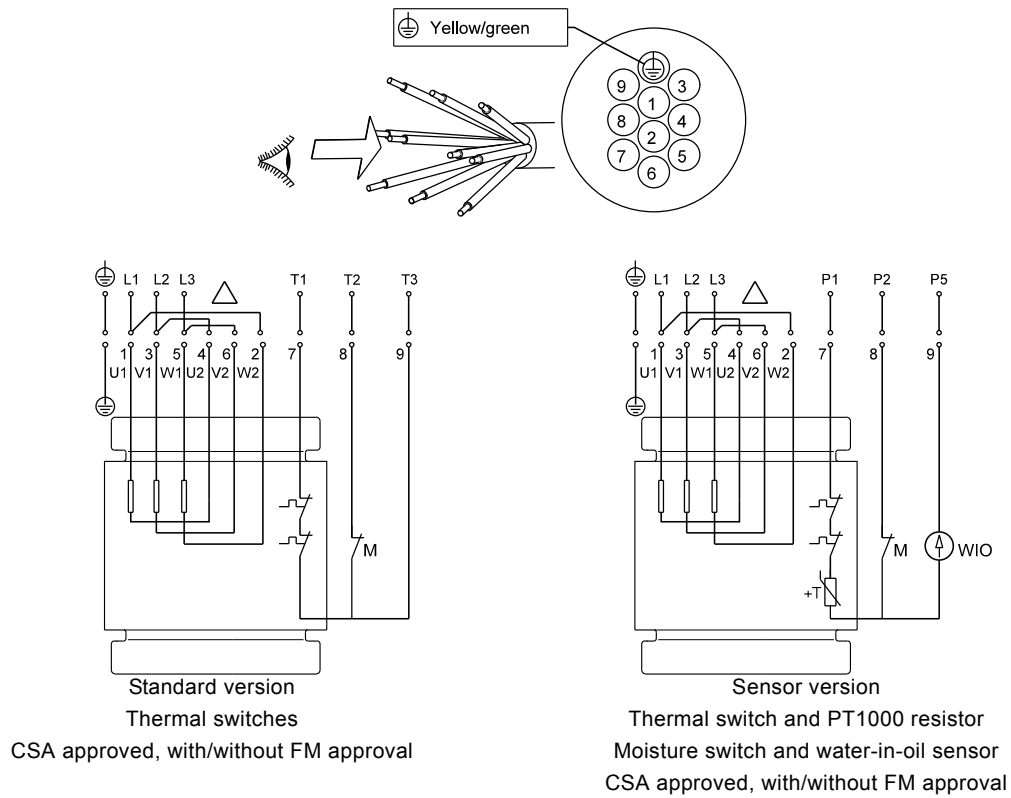

TM04 6692 0314

Fig. 9 Wiring diagram, 10-wire cable, Delta connected (D)

To find out whether the pump is fitted with a thermal switch or a PTC thermistor, measure the motor winding resistance. See table below.

	Without cable	With 10 m cable	With 15 m cable
Thermal switch	< 50 mΩ	< 320 mΩ	< 390 mΩ
PTC thermistor	> 100 mΩ	> 370 mΩ	> 440 mΩ

SL dual voltage concept

To standardize and help minimize part numbers and pump versions of the SL product portfolio, Grundfos created the 61R voltage variant. 61R is a dual-voltage (230 V/460 V), three phase, 60 Hz DOL (Direct-On-Line) connected motor.

- Connect 230 V pumps using the low-voltage (delta) connection.
- Connect 460 V pumps using the high-voltage (star) connection.

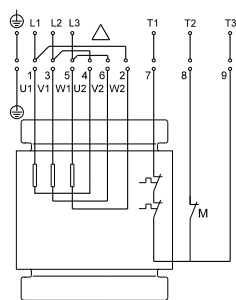

TM05 7155 0514

Fig. 10 61R 230 V DOL wired in low-voltage (delta) connection

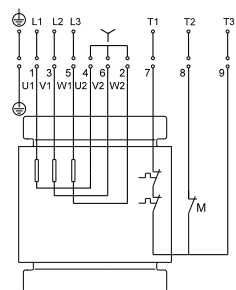

TM05 7156 0514

Fig. 11 61R, 460 V DOL wired in high-voltage (star) connection

The 61R voltage variant provides a large voltage range for supply power.

Stated voltage [V]	Percentage variation	Voltage range [V]
230	+/- 10 %	207-253
460	+/- 10 %	414-506

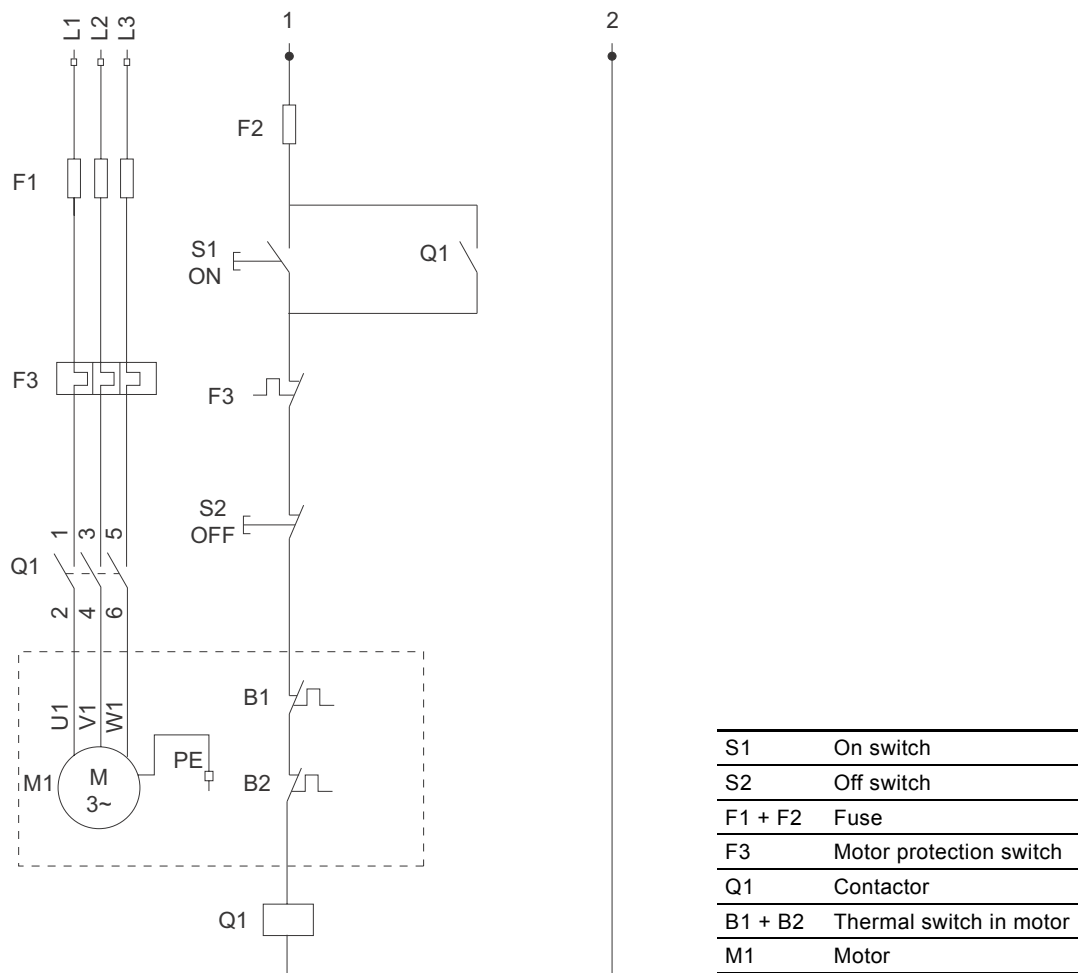

TM06 0523 0514

Fig. 12 Motor protection wiring diagram

9.2 Pump controllers

SL1 and SLV pumps can be connected to a separate controller for level control. Controllers are available as accessories:

- Grundfos DC pump controller for one-pump installations
- Grundfos DCD pump controller for two-pump installations
- Simplex controller, SLC, for one-pump installations
- Duplex controller, DLC, for up to six-pump installations.

For further information on controllers, please see the installation and operation instructions for the selected controller or go to www.us.grundfos.com.

9.3 Thermal switch, Pt1000 and thermistor

All SL1 and SLV pumps have thermal protection incorporated in the stator windings.

Pumps without WIO sensor

Pumps without WIO sensor have a thermal switch.

Via the pump controller safety circuit, the thermal switch will stop the pump by breaking the circuit in case of overtemperature (approx. 302 °F (150 °C)). The thermal switch will reclose the circuit after cooling.

The maximum operating current of the thermal switch is 0.5 A at 500 VAC and $\cos \varphi$ 0.6. The switch must be able to break a coil in the supply circuit.

Pumps with WIO sensor

Pumps with WIO sensor have either a thermal switch and a Pt1000 sensor or a thermistor (PTC) in the windings, depending on the installation site.

Via the pump controller safety circuit, the thermal switch or the thermistor will stop the pump by breaking the circuit in case of overtemperature (approx. 302 °F (150 °C)). The thermal switch or the thermistor will reclose the circuit after cooling.

The maximum operating current of both the Pt1000 and the thermistor is 1 mA at 24 VDC.

Non-explosion-proof pumps

When closing the circuit after cooling, the thermal protection can restart the pump automatically via the controller.

Explosion-proof pumps

Warning

The thermal protection of explosion-proof pumps must not restart the pump automatically. This ensures protection against overtemperature in potentially explosive environments. In pumps with sensor this is done by removing the short-circuit between terminals R1 and R2 in the IO 113. See Electrical data in the IO 113 installation and operating instructions.



Warning

The separate motor-protective circuit breaker/controller must not be installed in potentially explosive environments.

9.4 WIO sensor (water-in-oil sensor)

The WIO sensor measures the water content in the oil and converts the value into an analog current signal. The two sensor leads are for power supply and for carrying the signal to the IO 113. The sensor measures the water content from 0 to 20 %. It also sends a signal if the water content is outside the normal range (warning), or if there is air in the oil chamber (alarm). The sensor is fitted in a stainless steel tube for mechanical protection.

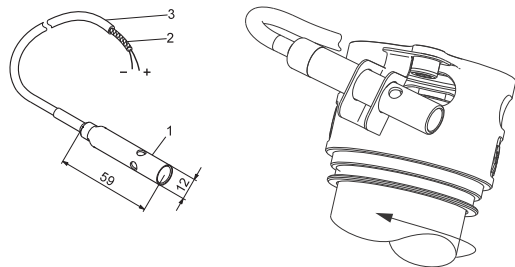

Fig. 13 WIO sensor

9.4.1 Fitting the WIO sensor

Fit the sensor next to one of the shaft seal openings. See fig. 13. The sensor must be tilted into the motor's direction of rotation to ensure that oil is led into the sensor. Make sure that the sensor is submerged in the oil.

9.4.2 Technical data

Input voltage:	12-24 VDC
Output current:	3.4 - 22 mA
Power input:	0.6 W
Ambient temperature:	32 to 158 °F (0 to 70 °C)

See also the installation and operating instructions for IO 113 on www.grundfos.us.

9.5 Moisture switch

All pumps are fitted with a moisture switch as standard, with the moisture switch being connected via the supply cable, see section 9. *Electrical connection*, and connected to a separate circuit breaker.

The moisture switch is positioned in the bottom of the stator housing. If there is moisture in the motor, the switch will break the circuit and send a signal to the IO 113.

The moisture switch is non-reversing and must be replaced after use.

The moisture switch is connected to the monitoring cable, and it must be connected to the safety circuit of the separate pump controller. See section 9. *Electrical connection*.

Caution

The motor-protective circuit breaker of the pump controller must include a circuit which automatically disconnects the power supply in case the protective circuit for the pump is opened.

9.6 IO 113

IO 113 provides an interface between a Grundfos wastewater pump equipped with sensors and the pump controller(s). The most important sensor status information is indicated on the front panel.

One pump can be connected to one IO 113 module.

Together with the sensors, the IO 113 provides a galvanic isolation between the motor voltage in the pump and the connected controller(s).

IO 113 can do the following as standard:

- Protect the pump against overheating.
- Monitor the status of these items:
 - motor winding temperature
 - leakage (WIO)
 - moisture in pump.
- Measure the stator insulation resistance.
- Stop the pump in case of alarm.
- Remotely monitor the pump via RS-485 communication (Modbus or GENIbus).
- Control the pump via a frequency converter.



Warning

IO 113 must not be used for purposes other than those specified above.

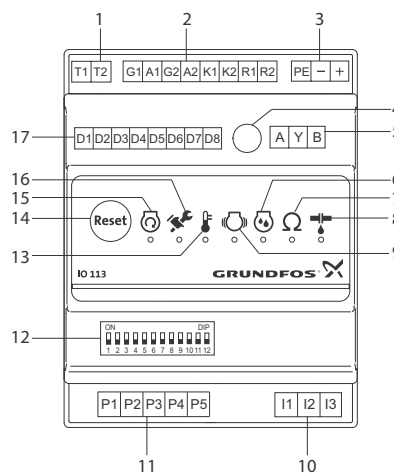

Fig. 14 IO 113 module

TM04 5238 2909 - TM03 1164 1105

TM05 1881 3811

Pos.	Description
1	Terminals for alarm relay
2	Terminals for analog and digital inputs and outputs
3	Terminals for supply voltage
4	Potentiometer for setting the warning limit of stator insulation resistance
5	Terminals for RS-485 for GENIbus or Modbus
6	Indicator light for moisture measurement
7	Indicator light for stator insulation resistance
8	Indicator light for leakage (WIO)
9	Indicator light for vibration in pump
10	Terminals for measurement of stator insulation resistance
11	Terminals for connection of pump sensors
12	DIP switch for configuration
13	Indicator light for motor temperature
14	Button for resetting alarms
15	Indicator light for motor running
16	Indicator light for service
17	Terminals for digital outputs

9.7 Frequency converter operation

All SL1/SLV pump types are designed for frequency converter operation to keep the energy consumption at a minimum.

To avoid the risk of sedimentation in the pipes, we recommend that you operate the speed-controlled pump at a flow rate above 3.28 ft/s (1 m/s).

For frequency converter operation, please observe the following information:

- Requirements must be fulfilled.
See section [9.7.1 Requirements](#)
- Recommendations ought to be fulfilled.
See section [9.7.2 Recommendations](#)
- Consequences should be considered.
See section [9.7.3 Consequences](#)

9.7.1 Requirements

- The thermal protection of the motor must be connected.
- Peak voltage and dU/dt must be in accordance with the table below. The values stated are maximum values supplied to the motor terminals. The cable influence has not been taken into account. See the frequency converter data sheet regarding the actual values and the cable influence on the peak voltage and dU/dt.

Maximum repetitive peak voltage [V]	Maximum dU/dt U _N 400 V [V/μ sec.]
850	2000

- If the pump is an FM-approved pump, check if the FM certificate of the specific pump allows the use of a frequency converter.
- Set the frequency converter U/f ratio according to the motor data.
- Local regulations/standards must be fulfilled.

9.7.2 Recommendations

Before installing a frequency converter, calculate the lowest allowable frequency in the installation in order to avoid zero flow.

- Do not reduce the motor speed to less than 30 % of rated speed.
- Keep the flow velocity above 3.28 ft/s (1 m/s).
- Let the pump run at rated speed at least once a day in order to prevent sedimentation in the piping system.
- Do not exceed the frequency indicated on the nameplate. In this case there is risk of motor overload.
- Keep the motor cable as short as possible. The peak voltage will increase with the length of the motor cable. See data sheet for the frequency converter used.
- Use input and output filters on the frequency converter. See data sheet for the frequency converter used.
- Use screened motor cable if there is a risk that electrical noise can disturb other electrical equipment. See data sheet for the frequency converter used.

9.7.3 Consequences

When operating the pump via a frequency converter, please be aware of these possible consequences:

- The locked-rotor torque will be lower. How much lower will depend on the frequency converter type. See the installation and operating instructions for the frequency converter used for information on the locked-rotor torque available.
- The working condition of bearings and shaft seal may be affected. The possible effect will depend on the application. The actual effect cannot be predicted.
- The acoustic noise level may increase. See the installation and operating instructions for the frequency converter used for advice as to how to reduce the acoustic noise.

10. Start-up



Warning

Before starting work on the pump, make sure that the fuses have been removed or the mains switch has been switched off. It must be ensured that the power supply cannot be accidentally switched on.

Make sure that all protective equipment has been connected correctly.

The pump must not run dry.



Warning

The pump must not be started if the atmosphere in the tank is potentially explosive.



Warning

It may lead to personal injuries or death to open the clamp while the pump is operating.

10.1 General start-up procedure

This procedure applies to new installations as well as after service inspections if start-up takes place some time after the pump was placed in the tank.

1. Remove the fuses and check that the impeller can rotate freely. Turn the impeller by hand.



Warning

The impeller can have sharp edges - wear protective gloves.

2. Check the condition of the oil in the oil chamber.
See also section [11.1 Inspection](#).
3. Check that the system, bolts, gaskets, pipework and valves etc. are in correct condition.
4. Mount the pump in the system.
5. Switch on the power supply.
6. Check whether the monitoring units, if used, are operating satisfactorily.
7. **For pumps with WIO sensor**, switch on the IO 113 and check that there are no alarms or warnings. See section [9.6 IO 113](#).
8. Check the setting of air bells, float switches or electrodes.
9. Check the direction of rotation. See section [10.3 Direction of rotation](#).
10. Open the isolating valves, if fitted.
11. Check that the liquid level is above the motor for S1 operation and above the cable entry for S3 operation. See fig. [15](#).
If the minimum level is not reached do not start the pump.
12. Start the pump and let the pump run briefly, and check if the liquid level is falling.
13. Observe if the discharge pressure and input current are normal. If not there might be air trapped inside the pump.

Note

Trapped air can be removed from the pump housing by tilting the pump by means of the lifting chain when the pump is in operation.

Caution

In case of abnormal noise or vibrations from the pump, other pump failure or power supply failure or water supply failure, stop the pump immediately. Do not attempt to restart the pump until the cause of the fault has been found and the fault corrected.

After one week of operation or after replacement of the shaft seal, check the condition of the oil in the chamber. For pumps without sensor, this is done by taking a sample of the oil, See section [11. Maintenance and service](#) for procedure.

Every time the pump has been removed from the tank, go through the above procedure when starting up again.

10.2 Operating modes

The pumps are designed for intermittent operation (S3). When completely submerged, the pumps can also operate continuously (S1).

S3, intermittent operation:

Operating mode S3 means that within 10 minutes the pump must be in operation for 4 minutes and stopped for 6 minutes. See fig. 15.

In this operating mode, the pump is partly submerged in the pumped liquid, i.e. the liquid level reaches at minimum the top of the cable entry on the stator housing. See fig. 2.

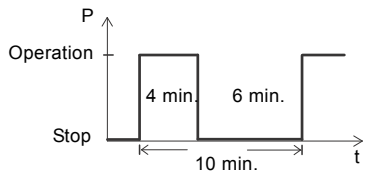

Fig. 15 S3, intermittent operation

S1, continuous operation:

In this operating mode, the pump can operate continuously without being stopped for cooling. See fig. 16. Being completely submerged, the pump is sufficiently cooled by the surrounding liquid. See fig. 2.

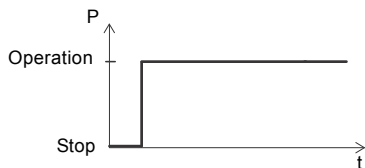

Fig. 16 S1, continuous operation

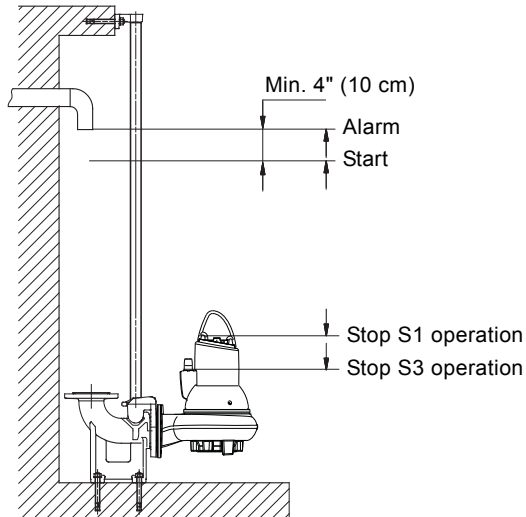

Fig. 17 Start and stop levels

Make sure that the effective volume of the tank does not become so low that the number of starts per hour exceeds the maximum permissible number.

10.3 Direction of rotation

Note The pump may be started for a very short period without being submerged to check the direction of rotation.

Check the direction of rotation before starting up the pump. An arrow on the stator housing indicates the correct direction of rotation. Correct direction of rotation is clockwise when viewed from above.

Checking the direction of rotation

The direction of rotation should be checked in the following way every time the pump is connected to a new installation.

Procedure

1. Let the pump hang from a lifting device, e.g. the hoist used for lowering the pump into the tank.
2. Start and stop the pump while observing the movement (jerk) of the pump. If connected correctly, the pump will rotate clockwise, i.e. it will jerk counter-clockwise. See fig. 18.
3. If the direction of rotation is wrong, interchange any two of the phases in the power supply cable. See fig. 6, 7 or 8, 9.

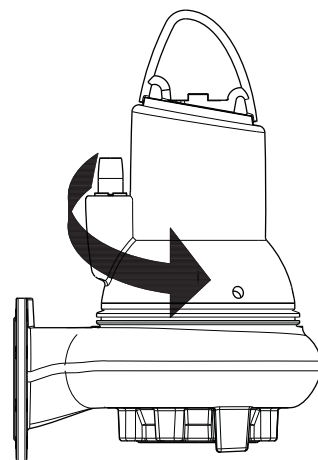

Fig. 18 Jerk direction

TM04 4527 1509

TM04 4528 1509

TM04 2654 2808

TM04 2657 2808

11. Maintenance and service



Warning

During maintenance and service, including transportation to service workshop, always support the pump by means of lifting chains or place it in horizontal position to secure stability.



Warning

Before starting work on the pump, make sure that the fuses have been removed or the mains switch has been switched off. It must be ensured that the power supply cannot be accidentally switched on.

Make sure that all protective equipment has been connected correctly.



Warning

Before starting work on the pump, make sure that the mains switch has been locked in position 0.

All rotating parts must have stopped moving.



Warning

Maintenance work on explosion-proof pumps must be carried out by FM approved service centres.

However, this does not apply to the hydraulic components, such as pump housing, impeller, etc.



Warning

The cable must only be replaced by Grundfos or a service workshop authorized by Grundfos.

Before carrying out maintenance and service, it must be ensured that the pump has been thoroughly flushed with clean water. Rinse the pump parts in water after dismantling.

11.1 Inspection

Pumps running normal operation should be inspected every 3000 operating hours or at least once a year. If the pumped liquid is very muddy or sandy, inspect the pump at shorter intervals.

Check the following points:

- **Power consumption**
See pump nameplate.
- **Oil level and oil condition**
When the pump is new or after replacement of the shaft seal, check the oil level and water content after one week of operation. If there is more than 20 % extra liquid (water) in the oil chamber, the shaft seal is defective. The oil should be changed after 3000 operating hours or once a year. Use Shell Ondina 919 oil or similar type. See section [11.2.1 Oil change](#).
- **Cable entry**
Make sure that the cable entry is watertight (visual inspection) and that the cable is not sharply bent and/or pinched.
- **Pump parts**
Check impeller, pump housing, etc. for possible wear. Replace defective parts. See section [11.2.2 Removing the pump housing and impeller](#).
- **Ball bearings**
Check the shaft for noisy or heavy operation (turn the shaft by hand). Replace defective ball bearings. A general overhaul of the pump is usually required in case of defective ball bearings or poor motor function. This work must be carried out by Grundfos or a service workshop authorized by Grundfos.



Warning

Defective bearings may reduce the explosion protection.

- **O-rings and similar parts**

During service/replacement, it must be ensured that the grooves for the O-rings as well as the seal faces have been cleaned before the new parts are fitted. Grease O-rings and recesses before assembly.

Note

Do not reuse rubber parts.

11.2 Dismantling the pump

Note

See www.grundfos.us for service videos.

11.2.1 Oil change

After 3000 operating hours or once a year, change the oil in the oil chamber as described below.

If the shaft seal has been replaced, the oil must be changed.



Warning

When loosening the screws of the oil chamber, note that pressure may have built up in the chamber. Do not remove the screws until the pressure has been fully relieved.

Draining of oil

1. Place the pump on a plane surface with one oil screw pointing downwards.
2. Place a suitable container (approx. 1 litre), for instance made of transparent plastic material, under the oil screw.

Note

Used oil must be disposed of in accordance with local regulations.

3. Remove the lower oil screw.
4. Remove the upper oil screw.
If the pump has been in operation for a long period of time, if the oil is drained off shortly after the pump has been stopped, and if the oil is greyish white like milk, it contains water. If the oil contains more than 20 % water, it is an indication that the shaft seal is defective and must be replaced. If the shaft seal is not replaced, the motor will be damaged.
If the quantity of oil is smaller than the quantity stated in section [11.4 Oil quantities](#), the shaft seal is defective.
5. Clean the faces for the gaskets for oil screws.

Filling with oil

1. Turn the pump so that the oil filling holes are placed opposite to each other, pointing upwards.

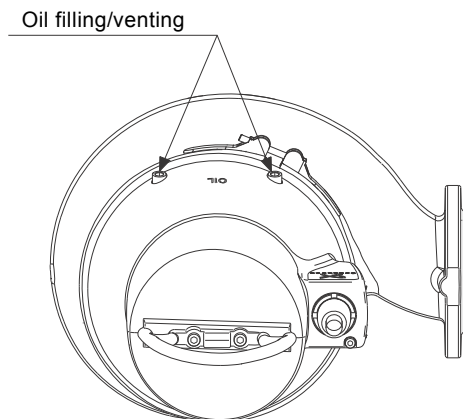

Fig. 19 Oil filling holes

2. Pour oil into the chamber.
For oil quantity, see section [11.4 Oil quantities](#).
3. Fit the oil screws with new gaskets.

11.2.2 Removing the pump housing and impeller

For position numbers, see pages [28](#) and [29](#).

Procedure

1. Loosen the clamp (pos. 92).
2. Remove the screw using your fingers.
3. Remove the pump housing (pos. 50) by inserting two screwdrivers between the stator housing and the pump housing.
4. Remove the screw (pos. 188a). Hold the impeller with a strap wrench.

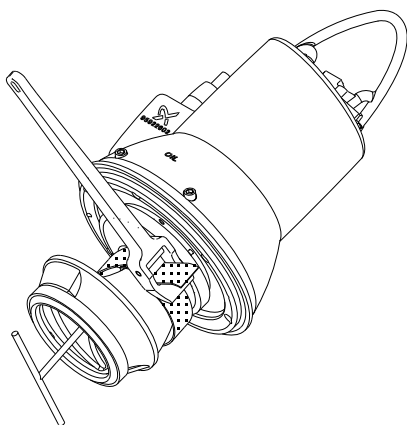

Fig. 20 Removing the impeller

5. Loosen the impeller (pos. 49) with a light blow on the edge. Pull it off.
6. Remove the key (pos. 9a) and the spring for impeller (pos. 157).

TM04 6477 0410

11.2.3 Removing the seal ring and wear ring

Procedure

1. Turn the pump housing upside-down.
2. Knock the seal ring (pos. 46) out of the pump housing using a punch.

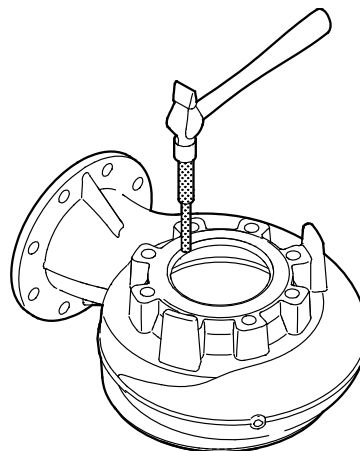

Fig. 21 Removing the seal ring

3. Clean the pump housing where the seal ring was fitted.
4. Remove the wear ring (pos. 49c) using a screwdriver.

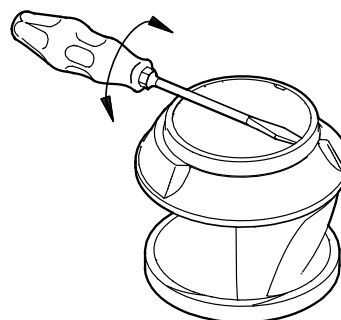

Fig. 22 Removing the wear ring

5. Clean the impeller where the wear ring was fitted.

11.2.4 Removing the shaft seal

Procedure

1. Remove the screws (pos. 188).
2. Remove the cover for oil chamber (pos. 58) using a puller.
3. Remove the screws (pos. 186).
4. Remove the shaft seal (pos. 105) using the puller.
5. Remove the O-ring (pos. 153b).

Procedure (pump with WIO sensor)

1. Remove the screws (pos. 188).
2. Remove the cover for oil chamber (pos. 58) using a puller.
3. Remove the screws (pos. 186).
4. Remove the sensor (pos. 521) and holder (pos. 522) from the shaft seal.
5. Remove the shaft seal (pos. 105) using the puller.
6. Remove the O-ring (pos. 153b).

TM02 8420 5103

TM02 8422 5103

11.3 Assembling the pump

11.3.1 Tightening torques and lubricants

Pos.	Designation	Quantity	Dim.	Torque [ft-lb (Nm)]	Lubricant
92a	Screw	1		8.85 ± 1.5 (12 ± 2)	
118a	Screw	2	M8	14.75 ± 1.5 (20 ± 2)	
			M10	22.15 ± 2.2 (30 ± 3)	
174	Screw	1		2.95 ± 0.74 (4 ± 1)	
181	Union nut	1	7-pole	36.88 ± 3.7 (50 ± 5)	
			10-pole	55.32 ± 3.7 (75 ± 5)	
186	Screw	2		5.2 + 1.5-0 (7+2-0)	
182	Screw	4		14.75 ± 1.5 (20 ± 2)	
187	Screw	4		14.75 ± 1.5 (20 ± 2)	
188	Screw	2	M8	14.75 ± 1.5 (20 ± 2)	
			M10	22.13 ± 2.2 (30 ± 3)	
188a	Screw	2	M10	36.88 + 3.7-0 (50+5-0)	
			M12	55.32 ± 3.7 (75 ± 5)	
193	Screw	2		11.8 ± 1.5 (16 ± 2)	
	O-rings	All			Rocol

Rocol Sapphire Aqua-Sil, product number RM2924 (1 kg).

Shell Ondina X-420 oil product No 96586753 (1 l)

Alternative:

Exxon Mobile Marcol 82 product number 98703313 (1 l)

JAX oil WMO 22 product number 98836788 (1 l)

11.3.2 Fitting the shaft seal

Procedure

1. Fit and lubricate the O-ring (pos. 153b) with oil.
2. Slide the shaft seal (pos. 105) gently over the shaft.
3. Fit and tighten the screws (pos. 186).
4. Fit and lubricate the O-ring (pos. 107) in the cover for oil chamber (pos. 58) with oil.
5. Fit the cover for oil chamber.
6. Fit and tighten the screws (pos. 188).

Procedure (pump with WIO sensor)

1. Fit and lubricate the O-ring (pos. 153b) with oil.
2. Slide the shaft seal (pos. 105) gently over the shaft.
3. Fit the holder (pos. 522) and sensor (pos. 521) with one of the screws (pos. 186).
4. Fit the second screw and tighten both screws (pos. 186).
5. Fit and lubricate the O-ring (pos. 107) in the cover for oil chamber (pos. 58) with oil.
6. Check that the sensor is positioned correctly. See [9.4.1 Fitting the WIO sensor](#) and fig. 13. This is of special importance in horizontal pumps.
7. Fit the cover for oil chamber.
8. Fit and tighten the screws (pos. 188).

11.3.3 Fitting the seal ring and wear ring

Procedure

1. Lubricate the seal ring (pos. 46) with soapy water.
2. Place the seal ring in the pump housing.
3. Knock the seal ring home in the pump housing using a punch or a wooden block.

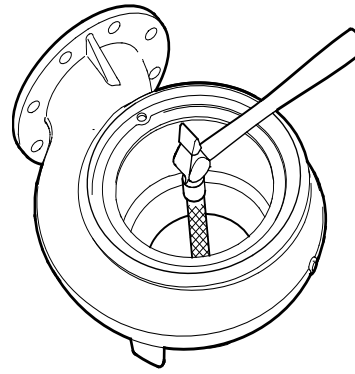

Fig. 23 Fitting the seal ring

4. Place the wear ring (pos. 49c) on the impeller.
5. Knock the wear ring home using a wooden block.

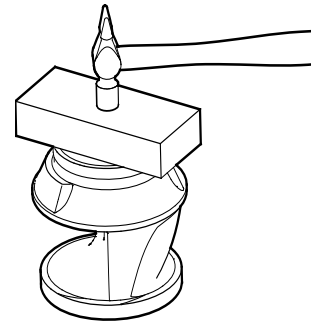

Fig. 24 Fitting the wear ring

11.3.4 Fitting the impeller and pump housing

Procedure

1. Fit the spring (pos. 157) and the key (pos. 9a).
Keep the key in position while the impeller is fitted.
2. Fit the impeller (pos. 49).
3. Fit the washer (pos. 66) and the screw (pos. 188a).
4. Tighten the screw (pos. 188a) to 55 ft-lb (75 Nm).
Hold the impeller with the strap wrench.
5. Mark the position of the pin on the pump housing.
6. Mark the position of the pin hole on the oil chamber.
7. Fit and lubricate the O-ring (pos. 37) with oil.
8. Fit the stator housing in the pump housing (pos. 50).
9. Fit the clamp (pos. 92).
10. Tighten the screw to 9 ft-lb (12 Nm).
11. Check that the impeller rotates freely and without drag.

11.4 Oil quantities

The table shows the quantity of oil in the oil chamber of SL1 and SLV pumps. Oil type: Shell Ondina X-420.

	Power [hp (kW)]	Oil quantity [oz (l)]
2-pole	3.0 (2.2)	20.3 (0.6)
	4.0 (3.0)	20.3 (0.6)
	5.5 (4.0)	33.8 (1.0)
	8.0 (6.0)	33.8 (1.0)
	10.0 (7.5)	33.8 (1.0)
	12.5 (9.2)	40.6 (1.2)
	15.0 (11)	40.6 (1.2)
4-pole	1.5 (1.1)	20.3 (0.6)
	1.8 (1.3)	20.3 (0.6)
	2.0 (1.5)	20.3 (0.6)
	3.0 (2.2)	20.3 (0.6)
	4.0 (3.0)	33.8 (1.0)
	5.5 (4.0)	33.8 (1.0)
	7.5 (5.5)	33.8 (1.0)
	10.0 (7.5)	40.6 (1.2)

Note

Used oil must be disposed of in accordance with local regulations.

11.5 Service kits

For service kits for SL1, SLV, see www.grundfos.us (Grundfos Product Center) or Service Kit Catalogue.

11.6 Contaminated pumps

Note

If a pump has been used for a liquid which is injurious to health or toxic, the pump will be classified as contaminated.

If Grundfos is requested to service the pump, Grundfos must be contacted with details about the pumped liquid, etc. *before* the pump is returned for service. Otherwise Grundfos can refuse to accept the pump for service.

Possible costs of returning the pump are to be paid by the customer.

However, any application for service (no matter to whom it may be made) must include details about the pumped liquid if the pump has been used for liquids which are injurious to health or toxic.

Before a pump is returned, it must be cleaned in the best possible way before it is returned.

Service instruction and service video can be found on www.grundfos.us.

12. Fault finding



Warning

Before attempting to diagnose any fault, make sure that the fuses have been removed or the mains switch has been switched off. It must be ensured that the power supply cannot be accidentally switched on.

All rotating parts must have stopped moving.



Warning

All regulations applying to pumps installed in potentially explosive environments must be observed.

It must be ensured that no work is carried out in potentially explosive atmosphere.

Note

For pumps with sensor, start fault finding by checking the status on the IO 113 front panel. See installation and operating instructions for IO 113.

Fault	Cause	Remedy
1. Motor does not start. Fuses blow or motor-protective circuit breaker trips out immediately. Caution: Do not start again!	a) Supply failure; short-circuit; earth-leakage fault in cable or motor winding.	Have the cable and motor checked and repaired by a qualified electrician.
	b) Fuses blow due to use of wrong type of fuse.	Fit fuses of the correct type.
	c) Impeller blocked by impurities.	Clean the impeller.
	d) Air bells, float switches or electrodes out of adjustment or defective.	Readjust or replace the air bells, float switches or electrodes.
	e) Moisture in the stator housing (alarm).* The IO 113 interrupts the supply voltage.	Replace the O-rings, the shaft seal and moisture switch.
	f) The WIO sensor is not covered by oil (alarm).* The IO 113 interrupts the supply voltage.	Check, and possibly replace, the shaft seal, fill up with oil and reset the IO 113.
	g) * Stator insulation resistance too low.	Reset alarm on IO 113. See installation and operating instructions for IO 113.
2. Pump operates, but motor-protective circuit breaker trips out after a short while.	a) Low setting of thermal relay in motor-protective circuit breaker.	Set the relay in accordance with the specifications on the nameplate.
	b) Increased current consumption due to large voltage drop.	Measure the voltage between two motor phases. Tolerance: - 10 %/+ 6 %. Reestablish correct voltage supply.
	c) Impeller blocked by impurities. Increased current consumption in all three phases.	Clean the impeller.
	d) Wrong direction of rotation.	Check the direction of rotation and possibly interchange any two of the phases in the incoming supply cable. See section 10.3 Direction of rotation .
3. The thermal switch of the pump trips out after a short while.	a) Too high liquid temperature.	Reduce the liquid temperature.
	b) Too high viscosity of the pumped liquid.	Dilute the pumped liquid.
	c) Wrong electrical connection. (If the pump is star-connected to a delta connection, the result will be very low undervoltage).	Check and correct the electrical installation.
4. Pump operates at below-standard performance and power consumption.	a) Impeller blocked by impurities.	Clean the impeller.
	b) Wrong direction of rotation.	Check the direction of rotation and possibly interchange any two of the phases in the incoming supply cable. See section 10.3 Direction of rotation .
5. Pump operates, but gives no liquid.	a) Discharge valve closed or blocked.	Check the discharge valve and possibly open and/or clean it.
	b) Non-return valve blocked.	Clean the non-return valve.
	c) Air in pump.	Vent the pump.
6. High power consumption (SLV).	a) Wrong direction of rotation.	Check the direction of rotation and possibly interchange any two of the phases in the incoming supply cable. See section 10.3 Direction of rotation .
	b) Impeller blocked by impurities.	Clean the impeller.
7. Noisy operation and excessive vibrations (SL1).	a) Wrong direction of rotation.	Check the direction of rotation and possibly interchange any two of the phases in the incoming supply cable. See section 10.3 Direction of rotation .
	b) Impeller blocked by impurities.	Clean the impeller.
8. Pump clogged.	a) The liquid contains large particles.	Select a pump with a larger size of passage.
	b) A float layer has formed on the surface of the liquid.	Install a mixer in the tank.

* Applies only to pumps with sensor and with IO 113.

13. Technical data

Supply voltage

- 3 x 208 V - 10 %/+ 10 %, 60 Hz
- 3 x 230 V - 10 %/+ 10 %, 60 Hz
- 3 x 380 V - 10 %/+ 10 %, 60 Hz
- 3 x 460 V - 10 %/+ 10 %, 60 Hz
- 3 x 575 V - 10 %/+ 10 %, 60 Hz

Enclosure class

IP68. According to IEC 60529.

Insulation class

H (356 °F (180 °C)).

Operating pressure

All pump housings are designed according to ASTM/ANSI B16 125 lb CLASS.

Dimensions

Discharge flanges are ANSI 2.5", ANSI 3", ANSI 4" or ANSI 6".

Pump curves

Pump curves are available via the internet on www.us.grundfos.com.

The curves are to be considered as a guide. They must not be used as guarantee curves.

Test curves for the supplied pump are available on request.

It must be ensured that the pump does not operate outside the recommended operating range during normal operation.

Pump noise emission < 70 dBA

- Sound power measurements were carried out according to ISO 3743.
- Sound power was calculated at a distance of 1 metre according to ISO 11203.

The sound pressure level of the pump is lower than the limiting values stated in the EC Council Directive 2006/42/EC relating to machinery.

2-pole motor					Cable connection	
Power P ₂ [hp (kW)]	Power P ₁ [hp (kW)]	Voltage [V]	Starting method	Thermal protection	Cable cross-section [AWG (mm ²)]	Conductors/pins
3.0 (2.2)	3.6 (2.7)	3 x 460	Y/D	Thermal switch	14 (2.5)	10/10
3.0 (2.2)	3.6 (2.7)	3 x 575	Y/D	Thermal switch	14 (2.5)	10/10
3.0 (2.2)	3.6 (2.7)	3 x 208-230	DOL	Thermal switch	14 (2.5)	10/7
3.0 (2.2)	3.6 (2.7)	3 x 230 / 3 x 460	Y/D	Thermal switch	14 (2.5)	10/10
4.0 (3.0)	4.7 (3.5)	3 x 460	Y/D	Thermal switch	14 (2.5)	10/10
4.0 (3.0)	4.7 (3.5)	3 x 575	Y/D	Thermal switch	14 (2.5)	10/10
4.0 (3.0)	4.7 (3.5)	3 x 208-230	DOL	Thermal switch	14 (2.5)	10/7
4.0 (3.0)	4.7 (3.5)	3 x 230 / 3 x 460	Y/D	Thermal switch	14 (2.5)	10/10
5.5 (4.0)	6.2 (4.6)	3 x 460	Y/D	Thermal switch	14 (2.5)	10/10
5.5 (4.0)	6.2 (4.6)	3 x 575	Y/D	Thermal switch	14 (2.5)	10/10
5.5 (4.0)	6.2 (4.6)	3 x 208-230	DOL	Thermal switch	14 (2.5)	10/7
5.5 (4.0)	6.2 (4.6)	3 x 230 / 3 x 460	Y/D	Thermal switch	14 (2.5)	10/10
8.0 (6.0)	9.1 (6.8)	3 x 460	Y/D	Thermal switch	14 (2.5)	10/10
8.0 (6.0)	9.1 (6.8)	3 x 575	Y/D	Thermal switch	14 (2.5)	10/10
8.0 (6.0)	9.1 (6.8)	3 x 208-230	DOL	Thermal switch	14 (2.5)	10/7
8.0 (6.0)	9.1 (6.8)	3 x 230 / 3 x 460	Y/D	Thermal switch	14 (2.5)	10/10
10 (7.5)	11.1 (8.3)	3 x 460	Y/D	Thermal switch	14 (2.5)	10/10
10 (7.5)	11.1 (8.3)	3 x 575	Y/D	Thermal switch	14 (2.5)	10/10
10 (7.5)	11.1 (8.3)	3 x 208-230	DOL	Thermal switch	14 (2.5)	10/7
10 (7.5)	11.1 (8.3)	3 x 230 / 3 x 460	Y/D	Thermal switch	14 (2.5)	10/10
12.5 (9.2)	13.9 (10.4)	3 x 460	Y/D	Thermal switch	14 (2.5)	10/10
12.5 (9.2)	13.9 (10.4)	3 x 575	Y/D	Thermal switch	14 (2.5)	10/10
12.5 (9.2)	13.9 (10.4)	3 x 208-230	DOL	Thermal switch	14 (2.5)	10/7
12.5 (9.2)	13.9 (10.4)	3 x 230 / 3 x 460	Y/D	Thermal switch	14 (2.5)	10/10
15 (11)	16.2 (12.1)	3 x 460	Y/D	Thermal switch	14 (2.5)	10/10
15 (11)	16.2 (12.1)	3 x 575	Y/D	Thermal switch	14 (2.5)	10/10
15 (11)	16.2 (12.1)	3 x 208-230	DOL	Thermal switch	14 (2.5)	10/7
15 (11)	16.2 (12.1)	3 x 230 / 3 x 460	Y/D	Thermal switch	14 (2.5)	10/10

The resistance in the supply cable depends on the cable diameter.

Resistance per metre of cable: AWG 16 (1.5 mm²) = 0.013 OHM - CSA/FM

Resistance per metre of cable: AWG 14 (2.5 mm²) = 0.00830 OHM - CSA/FM

4-pole motor					Cable connection	
Power P ₂ [hp (kW)]	Power P ₁ [hp (kW)]	Voltage [V]	Starting method	Thermal protection	Cable cross-section [mm ²]	Conductors/pins
1.5 (1.1)	1.7 (1.3)	3 x 575	Y/D	Thermal switch	16 (1.5)	10/10
1.5 (1.1)	1.7 (1.3)	3 x 575	DOL	Thermal switch	16 (1.5)	7/7
1.5 (1.1)	1.7 (1.3)	3 x 208-230	DOL	Thermal switch	16 (1.5)	7/7
1.5 (1.1)	1.7 (1.3)	3 x 230 / 3 x 460	Y/D	Thermal switch	14 (2.5)	10/10
1.8 (1.3)	2.1 (1.6)	3 x 575	Y/D	Thermal switch	16 (1.5)	10/10
1.8 (1.3)	2.1 (1.6)	3 x 575	DOL	Thermal switch	16 (1.5)	7/7
1.8 (1.3)	2.2 (1.7)	3 x 208-230	DOL	Thermal switch	16 (1.5)	7/7
1.8 (1.3)	2.2 (1.7)	3 x 230 / 3 x 460	Y/D	Thermal switch	14 (2.5)	10/10
2.0 (1.5)	2.2 (1.7)	3 x 575	Y/D	Thermal switch	16 (1.5)	10/10
2.0 (1.5)	2.2 (1.7)	3 x 575	DOL	Thermal switch	16 (1.5)	7/7
2.0 (1.5)	2.4 (1.8)	3 x 208-230	DOL	Thermal switch	16 (1.5)	7/7
2.0 (1.5)	2.4 (1.8)	3 x 230 / 3 x 460	Y/D	Thermal switch	14 (2.5)	10/10
3.0 (2.2)	3.4 (2.6)	3 x 460	Y/D	Thermal switch	14 (2.5)	10/10
3.0 (2.2)	3.3 (2.5)	3 x 575	Y/D	Thermal switch	14 (2.5)	10/10
3.0 (2.2)	3.3 (2.5)	3 x 208-230	DOL	Thermal switch	14 (2.5)	10/7
3.0 (2.2)	3.4 (2.6)	3 x 230 / 3 x 460	Y/D	Thermal switch	14 (2.5)	10/10
4.0 (3.0)	4.5 (3.4)	3 x 460	Y/D	Thermal switch	14 (2.5)	10/10
4.0 (3.0)	4.4 (3.3)	3 x 575	Y/D	Thermal switch	14 (2.5)	10/10
4.0 (3.0)	4.4 (3.3)	3 x 208-230	DOL	Thermal switch	14 (2.5)	10/7
4.0 (3.0)	4.5 (3.4)	3 x 230 / 3 x 460	Y/D	Thermal switch	14 (2.5)	10/10
5.5 (4.0)	6.1 (4.6)	3 x 460	Y/D	Thermal switch	14 (2.5)	10/10
5.5 (4.0)	6.0 (4.5)	3 x 575	Y/D	Thermal switch	14 (2.5)	10/10
5.5 (4.0)	6.0 (4.5)	3 x 208-230	DOL	Thermal switch	14 (2.5)	10/7
5.5 (4.0)	6.1 (4.6)	3 x 230 / 3 x 460	Y/D	Thermal switch	14 (2.5)	10/10
7.5 (5.5)	8.1 (6.1)	3 x 460	Y/D	Thermal switch	14 (2.5)	10/10
7.5 (5.5)	8.0 (6.0)	3 x 575	Y/D	Thermal switch	14 (2.5)	10/10
7.5 (5.5)	8.0 (6.0)	3 x 208-230	DOL	Thermal switch	14 (2.5)	10/7
7.5 (5.5)	8.1 (6.1)	3 x 230 / 3 x 460	Y/D	Thermal switch	14 (2.5)	10/10
10 (7.5)	11.1 (8.3)	3 x 460	Y/D	Thermal switch	14 (2.5)	10/10
10 (7.5)	11.0 (8.2)	3 x 575	Y/D	Thermal switch	14 (2.5)	10/10
10 (7.5)	11.0 (8.2)	3 x 208-230	DOL	Thermal switch	14 (2.5)	10/7
10 (7.5)	11.1 (8.3)	3 x 230 / 3 x 460	Y/D	Thermal switch	14 (2.5)	10/10

The resistance in the supply cable depends on the cable diameter.

Resistance per metre of cable: AWG 16 (1.5 mm²) = 0.013 OHM - CSA/FM

Resistance per metre of cable: AWG 14 (2.5 mm²) = 0.00830 OHM - CSA/FM

14. Disposal

This product or parts of it must be disposed of in an environmentally sound way:

1. Use the public or private waste collection service.
2. If this is not possible, contact the nearest Grundfos company or service workshop.

Subject to alterations.

Exploded drawings

SL1

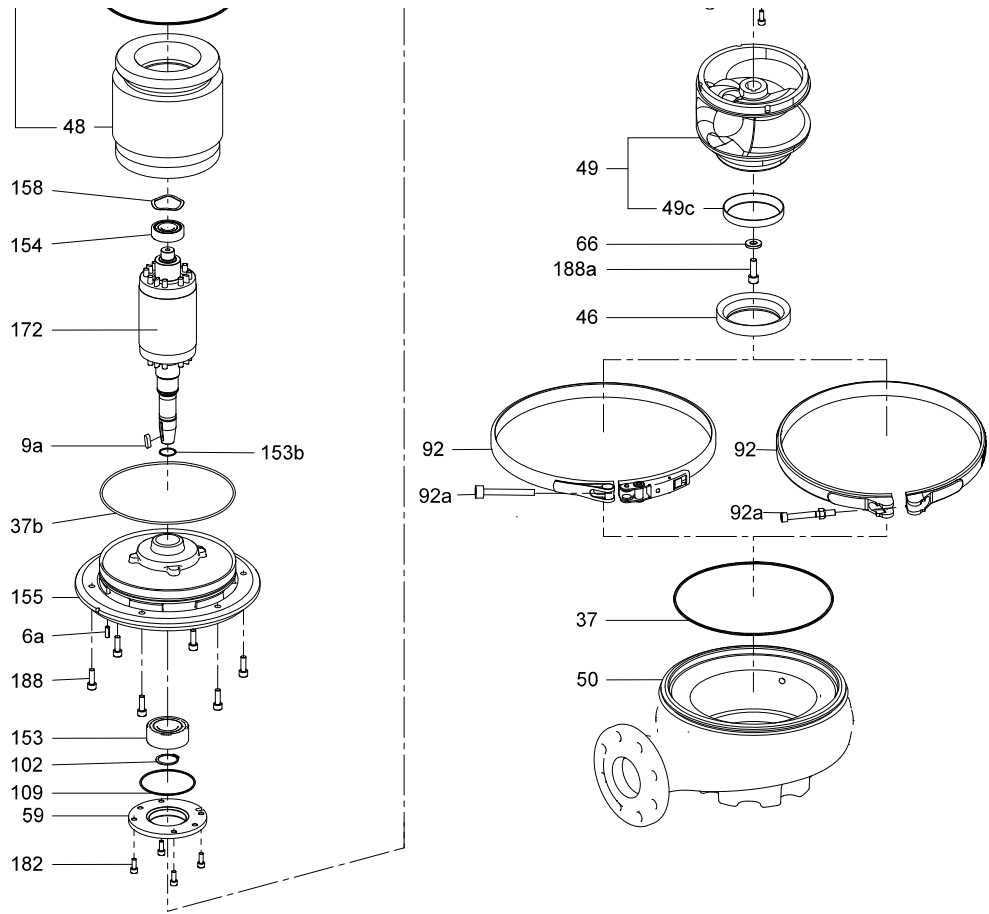

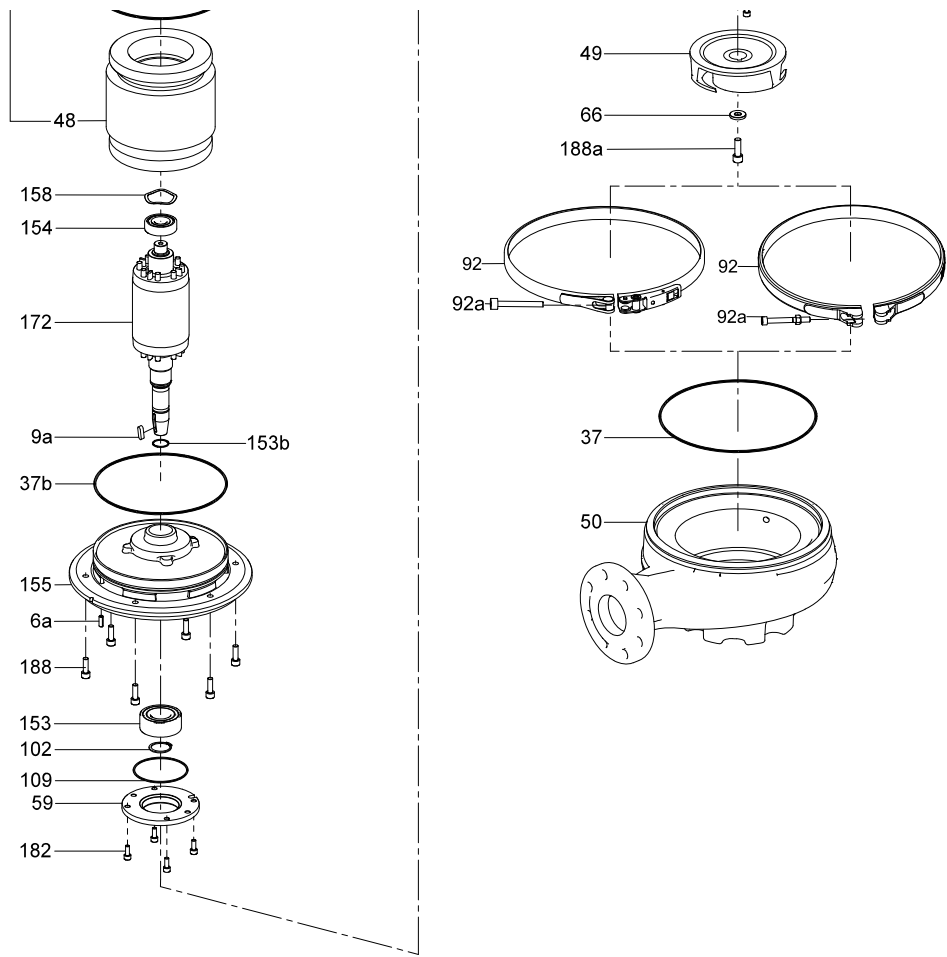

GRUNDFOS Kansas City

17100 West 118th Terrace
Olathe, Kansas 66061
Phone: (913) 227-3400
Fax: (913) 227-3500

www.grundfos.us

GRUNDFOS Canada

2941 Brighton Road
Oakville, Ontario L6H 6C9 Canada
Phone: +1-905 829 9533
Telefax: +1-905 829 9512

www.grundfos.ca

GRUNDFOS México

Boulevard TLC No. 15
Parque Industrial Stiva Aeropuerto
C.P. 66600 Apodaca, N.L. México
Phone: 011-52-81-8144 4000
Fax: 011-52-81-8144 4010

www.grundfos.mx

97640137 0116
ECM: 1173575

The name Grundfos, the Grundfos logo, and be think innovate are registered trademarks owned by Grundfos Holding A/S or Grundfos A/S, Denmark. All rights reserved worldwide. © Copyright Grundfos Holding A/S