



Boiler MicroVision

Programmable Boiler Controller

ORDER ONLINE www.PumpCatalog.com

Pulsafeeder Expertise

Technology is the key to delivering responsible products to the markets that we serve. Leading the way in the development of metering technologies, Pulsafeeder continues to set the standard for accuracy, reliability and safety.

Innovation is another hallmark of Pulsafeeder. Helping customers find a new approach to an old problem is what we do best.



MicroVision Boiler Controller

The MicroVision Boiler Controller delivers comprehensive boiler water control with 'plug & play' simplicity, at an outstanding value. This latest addition to the MicroVision family of controllers is configured specifically for boiler water control, and utilizes intuitive software which provides simple set-up, while providing state of the art maintenance of the water in your boiler. Features of this device include a reliable temperature compensated conductivity probe, 5 output relays with selectable timers, scalable 4-20mA output to report conductivity, hall-effect and pulse water meter inputs, digital drum levels and a boiler interlock input.

Controller Specifications

- Enclosure: NEMA 4X / IP65
- Dimensions: 243.3 x 185 x 132 mm (9.58 x 7.25 x 5.20in)
- Power Supply: 100-240VAC ±10% 5A, 50/60hz
- Control Output: Prewired relay - 5A max; Dry contact - 1A per relay
- Display: LCD

Standard Sensor Specifications

- Max. Temp: 200°C (392°F)
- Max. Pressure: 17 Bar (250 psi)
- Saturated Steam Max.: 14.4 Bar(210 psi)
- Conductivity Range: 0 to 20,000 µS/cm
- Cell Constant and TC: 1.0 PT-1000 RTD
- Wetted Materials: 316 SS and PEEK

Typical Applications

- Comfort Heat Process
- Industrial Boilers

Input and Output Functionality

System Outputs	Blowdown	Timer 1	Timer 2	Timer 3	Alarm/Timer 4
Output Type	Relay 1	Relay 2	Relay 3	Relay 4	Dry Contact
28 Day		X	X	X	X
Pulse		X	X	X	X
Percent		X	X	X	X
Cycle		X	X	X	X
System Alarm					X
Programmable Inputs	Input 1	Input 2	Input 3	Input 4	Input 5
Drum Level		X	X	X	X
Dry Contact Water meter	X	X	X	X	X
Hall effect	X				
Interlock					X

Boiler Controller Technology

Pulsafeeder's line of Boiler Controllers are designed for simplicity and reliability. Offering affordable, high performance Boiler Controllers that are easy to specify and easy to use. Pulsafeeder Boiler Controllers offer versatile solutions to your fluid control problems. With selectable sampling modes, powered relays, selectable timers, and inputs to fit your needs. Pulsafeeder's MicroVision Boiler controller increases energy efficiency, reduces water consumption, reduces manpower and optimizes chemical utilization.

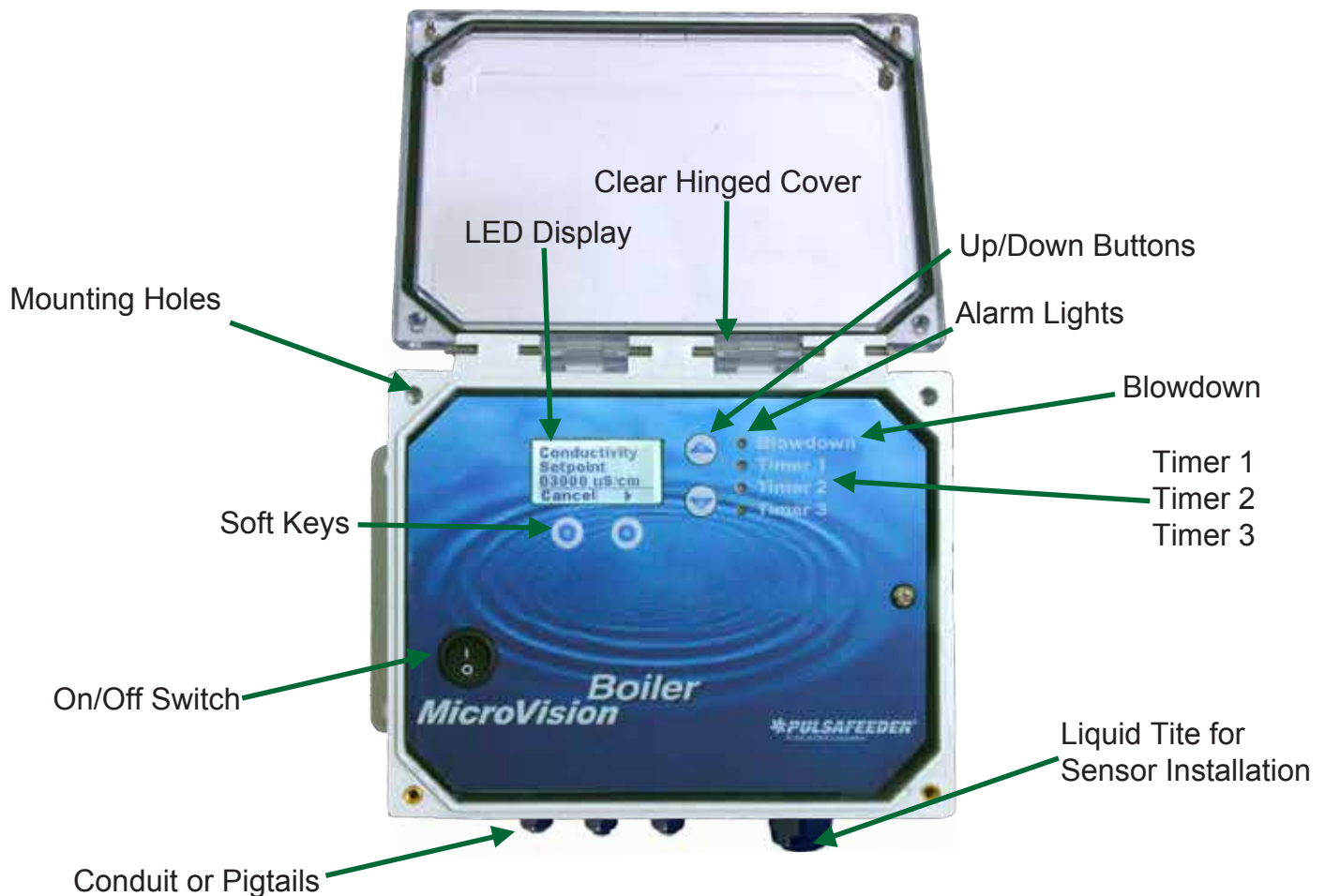

Features & Benefits



Simple Programming

- Factory preset to operate in timed sample mode right out of the box
- Intuitive menus make program alterations easy and understandable

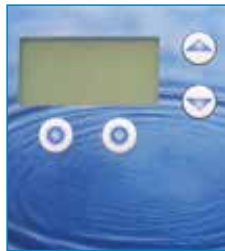

Easy Installation and Easy to Use

- Pre-wired and conduit connections options make easy installation
- Large graphical display with status screen for instant access to system information
- LED function indicators
- Touch pad program keys provide clear and precise system information



Reliable Conductivity Probe

- Standard conductivity probe is rugged and reliable
- Temperature compensated for accurate readings from 0-20,000 μ S



Selectable Sampling Modes

- Continuous
- Timed Sample
- Sample & Hold



5 Output Relays

- 1 powered relay for motorized ball valves or solenoid blowdown valves
- 3 powered relays for chemical metering pumps
- 1 dry contact relay for remote alarm

System Options

Timed Sample

Optional Valves available

- 1/2" Solenoid Valve
- (1) 1" Orifice Union with 4 plates
- 1/2" Motorized Ball Valve
- (1) 1/2" flow throttling valve
- 1/2" Motorized Ball Valve
- (1) 1" Orifice Union with 4 plates

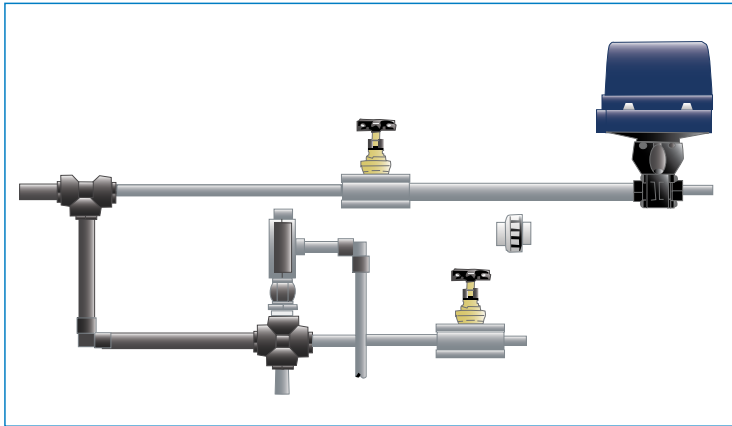
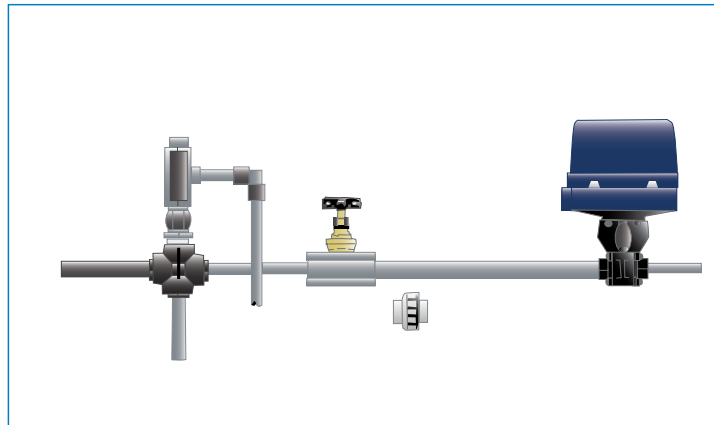

Continuous Sample

Optional Valves available

- 3/4" Motorized Ball Valve,
- (1) 3/4" throttling valve,
- (1) 1/2" throttling valve
- 3/4" Motorized Ball Valve
- (2) 1" Orifice Union with 4 plates

Flow Assembly

- High Pressure Flow Assembly used for cooling tower applications
- 250 psi max

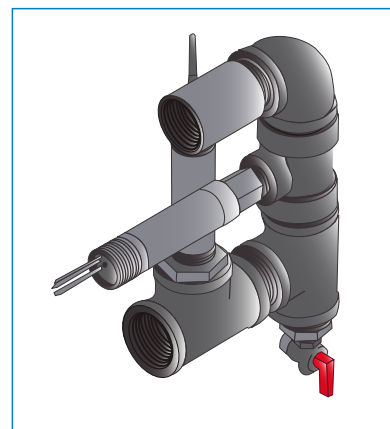

MicroVision Boiler Typical Installation

Typical Installation Includes:

- Ball Valve
- Throttling Valve
- Orifice Union and Plates
- Cross

All Available from Pulsafeeder!

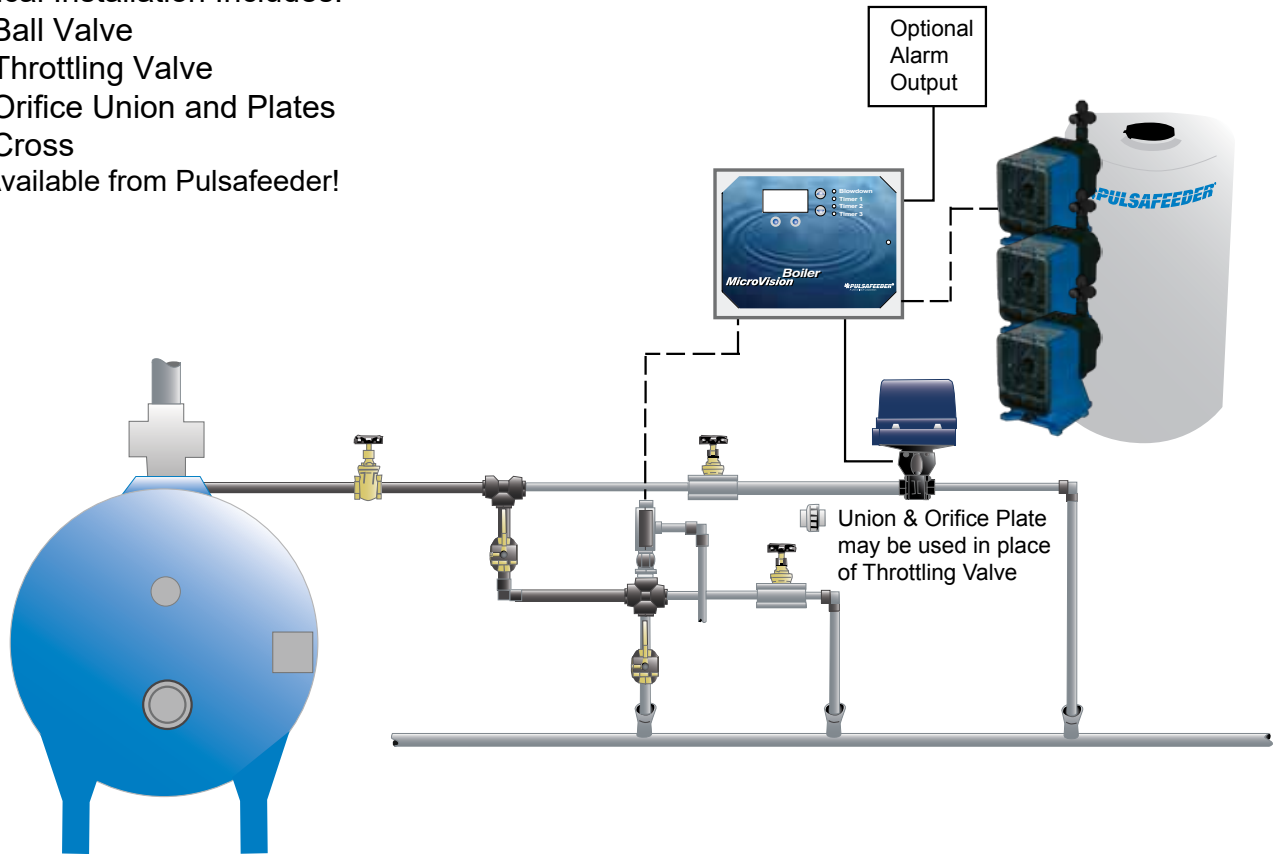

Continuous Sample

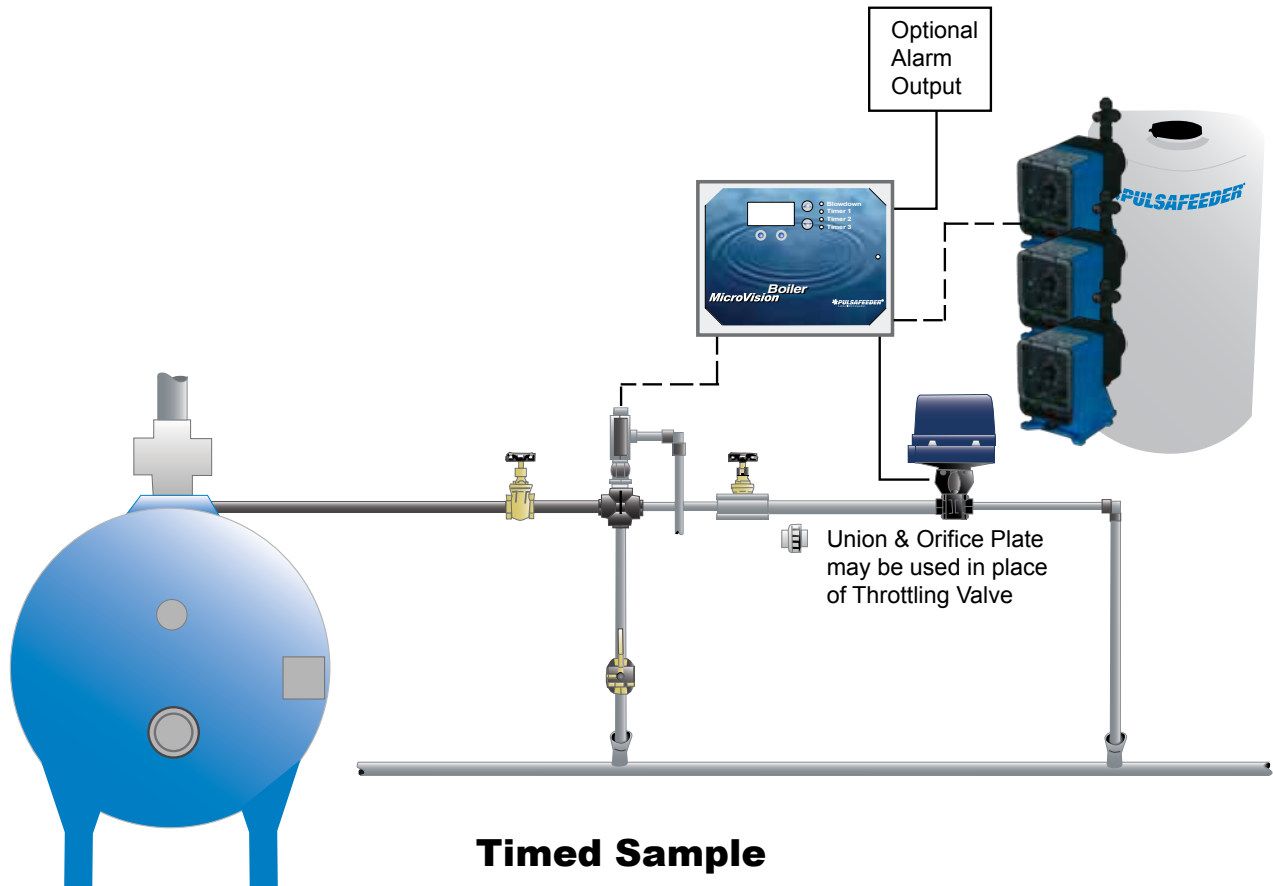

Timed Sample

Parts & Accessories



PULSAtron Series Electronic Metering Pumps

The PULSAtron Series A PLUS and E PLUS electronic metering pumps can be used with the MicroVision Series controller for timer based chemical metering.



A **Sample Cooler** provides a safe method of withdrawing and cooling boiler process water for analysis. Our 304SS coolers are easy to install, and handle sample pressures to 2500 PSI.



Contacting Head Water Meters Multi-Jet Meters

3/4 in. to 2 in., are designed for use in conjunction with a pulse timer to proportionally control pumps, valves etc. The Multi-Jet chamber of the water meter assures accuracy over a wide range of flows with low head loss.



Valve Packages - System Options

Materials of construction: Solenoid Valves are bronze body with stainless steel pilot and valves; Motorized Ball Valves are carbon steel body with 316 stainless steel ball and stem; Throttling Valves are carbon steel body and valve; and Orifice Unions are carbon steel union with stainless steel plates.



Flow Control Valves - Boiler Applications

Flow control valves maintain sufficient back pressure in boiler blowdown lines in order to prevent flashing and to ensure adequate blowdown rates. The orifice union includes four plates, 1/16", 1/8", 1/4" and a 5/16". Flow control valves include an indexed position indicator.