

EOM

Engineering Operation
& Maintenance

Equalizer[®]

Surge Dampeners

Integrated SD Series (ISD)

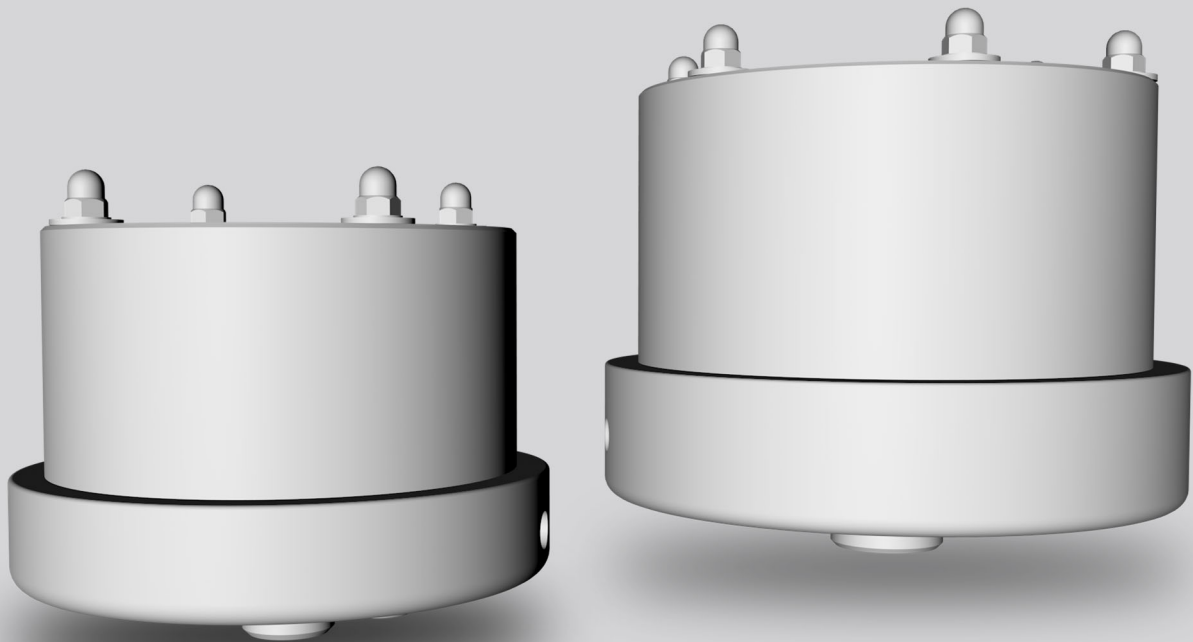

Where Innovation Flows

WILDEN[®]



WIL-19012-E

TABLE OF CONTENTS

SECTION 1	CAUTIONS—READ FIRST!	2
SECTION 2	WILDEN PUMP DESIGNATION SYSTEM	3
SECTION 3	DIMENSIONAL DRAWINGS	
	ISD100 PTFE-Fitted.....	4
	ISD200 PTFE-Fitted.....	4
SECTION 4	PERFORMANCE	
	ISD100 PTFE-Fitted.....	5
	ISD200 PTFE-Fitted.....	6
SECTION 5	SUGGESTED INSTALLATION, OPERATION & MAINTENANCE	7
SECTION 6	TROUBLESHOOTING / WARRANTY INFORMATION	8

CAUTIONS – READ FIRST!

CAUTION: Do not apply compressed air to the exhaust port — pump will not function.

CAUTION: Do not exceed 7 bar (100 psig) air supply pressure.

Temperature Limits:

EPDM	-51°C to 138°C	-60°F to 280°F
Nylon	-18°C to 93°C	0°F to 200°F
IPD PTFE with EPDM-backed	10°C to 137°C	14°F to 280°F
Polyethylene	0°C to 70°C	32°F to 158°F

CAUTION: When choosing dampener materials, be sure to check the temperature limits for all wetted components.

CAUTION: Maximum temperature limits are based upon mechanical stress only. Certain chemicals will significantly reduce maximum safe operating temperatures. Consult the Chemical Resistance Guide for chemical compatibility and temperature limits.

WARNING: Prevent static sparking. If static sparking occurs, fire or explosion could result. Pump, valves and containers must be grounded to a proper grounding point when handling flammable fluids and whenever discharge of static electricity is a hazard.

CAUTION: The process fluid and cleaning fluids must be chemically compatible with all wetted pump components.

CAUTION: Dampener(s) should be thoroughly flushed before installing into process lines.

CAUTION: Always wear safety glasses when operating pump. If diaphragm rupture occurs, material being pumped may be forced out air exhaust.

CAUTION: Before any maintenance or repair is attempted, the compressed air line to the dampener and pump should be disconnected and all air pressure allowed to bleed from system. Disconnect all intake, discharge and air lines. Drain the dampener by turning it upside down and allowing any fluid to flow into a suitable container.

CAUTION: Blow out air line for 10 to 20 seconds before attaching to pump to make sure all pipeline debris is clear. Use an in-line air filter. A 5 μ (micron) air filter is recommended.

CAUTION: Dampeners cannot be used in submersible applications.

CAUTION: Tighten all hardware prior to installation.

EQUALIZER® SURGE DAMPENERS – INTEGRATED SD SERIES (ISD)

WILDEN PUMP DESIGNATION SYSTEM

LEGEND

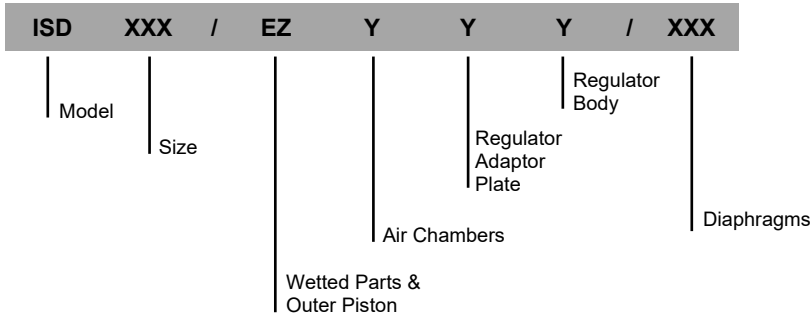

MATERIAL CODES

MODEL

ISD = INTEGRATED SD SERIES

SIZE

100 = 13 mm (1/2")
 200 = 25 mm (1")

WETTED PARTS/OUTER PISTON

EZ = POLYETHYLENE/
 NOT APPLICABLE

AIR CHAMBERS

Y = NYLON

REGULATOR ADAPTOR PLATE

Y = NYLON

REGULATOR BODY

Y = NYLON

DIAPHRAGMS

EPL = EPDM IPD
 LEL = PTFE EPDM BACKED,
 IPD (WHITE)

Note: Most elastomeric materials use colored dots for identification. Not all models are available with all material options.

DIMENSIONAL DRAWINGS – ISD100 PTFE-Fitted

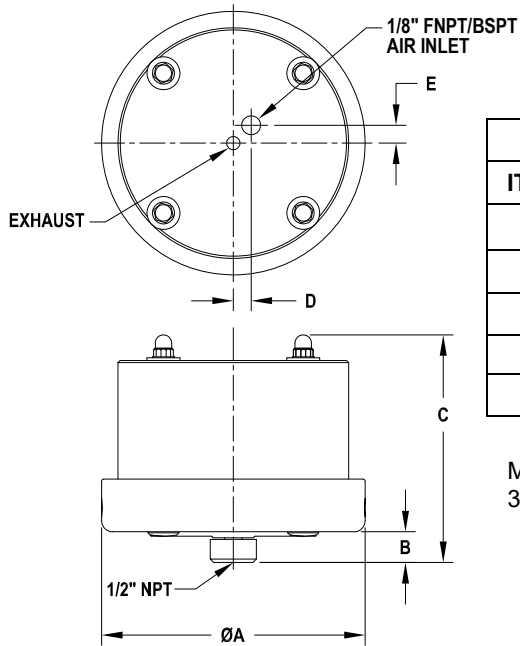

DIMENSIONS – ISD 100 (PLASTIC)		
ITEM	METRIC (mm)	STANDARD (inch)
A	120	4.7
B	14	.6
C	104	4.1
D	8	.3
E	8	.3

LW0486 REV. A

Maximum Torque Specifications
3 N•m (2.2 ft-lbs)

DIMENSIONAL DRAWINGS – ISD200 PTFE-Fitted

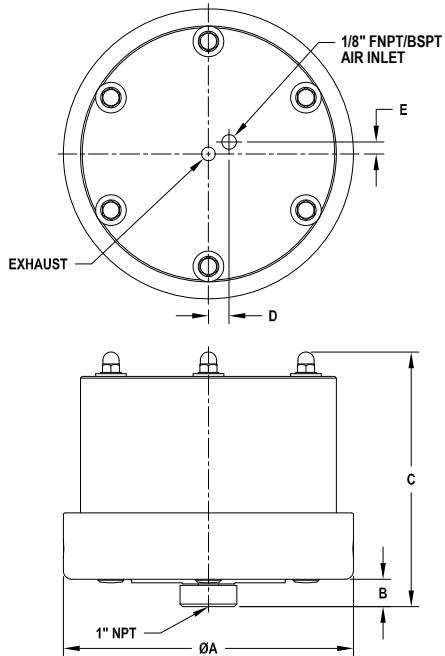

DIMENSIONS – ISD200 (PLASTIC)		
ITEM	METRIC (mm)	STANDARD (inch)
A	170	6.7
B	16	.6
C	149	5.9
D	12	.5
E	7	.3

LW0487 REV. A

Maximum Torque Specifications
6 N•m (4.4 ft-lbs)

PERFORMANCE – ISD100 PTFE-FITTED

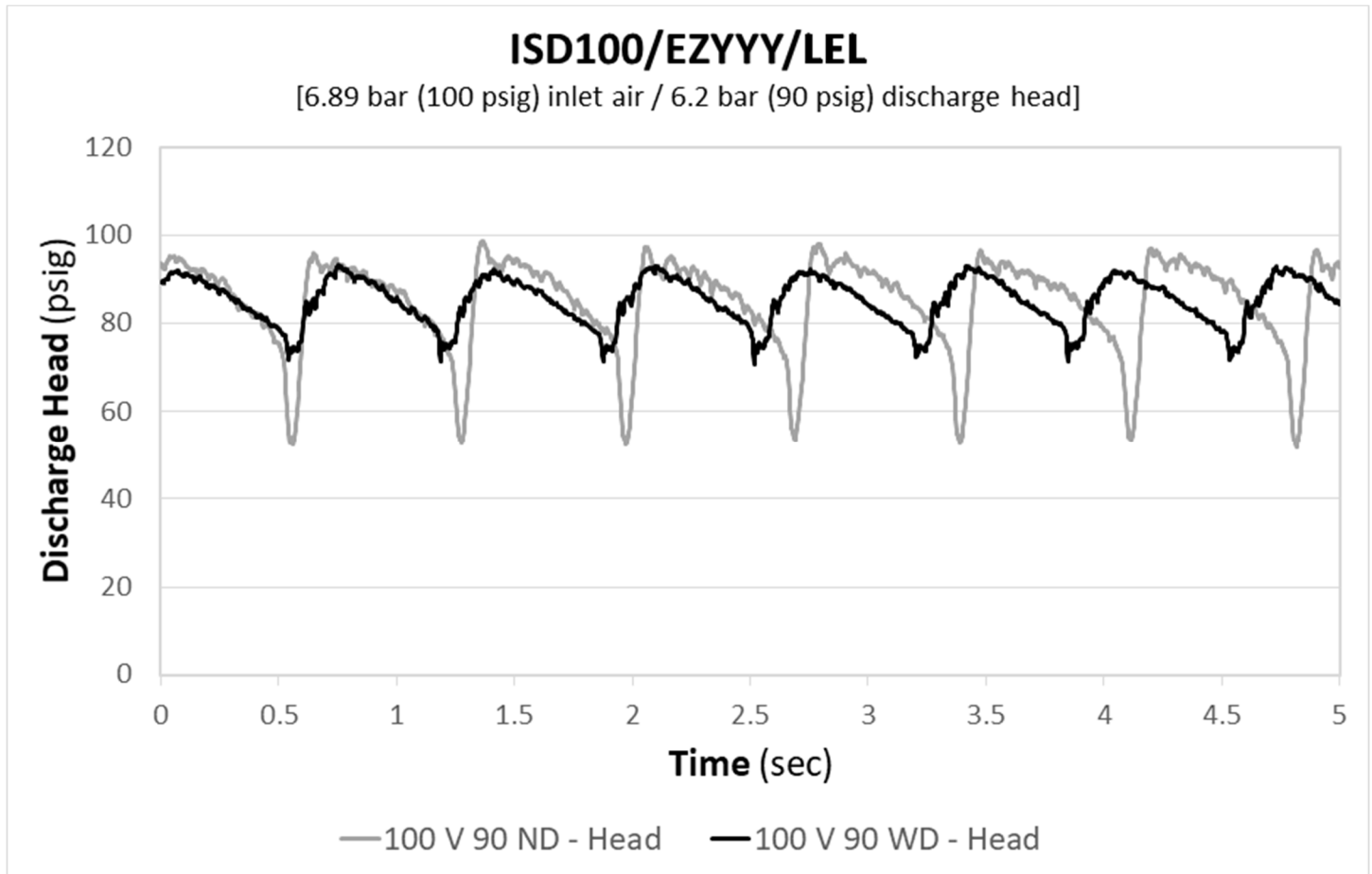

This chart shows discharge head fluctuations for a diaphragm pump with and without a dampener. By reviewing the variation in pressure, the level of dampening can be estimated for an application. For example, the head pressure generated by a 13 mm (1/2") pump operating at 6.89 bar (100 psig) air inlet pressure and 6.2 bar (90 psig) head pressure varies between 3.5 bar (52 psig) and 6.7 bar (98 psig) resulting in a total pressure fluctuation of 3.2 bar (46 psig) for each stroke. When an ISD100/EZYZZY/LEL dampener is installed in the application, the head pressure varies between 4.8 bar (70 psig) and 6.4 bar (93 psig) resulting in a pressure fluctuation of only 1.6 bar (23 psig).

PERFORMANCE – ISD200 PTFE-FITTED

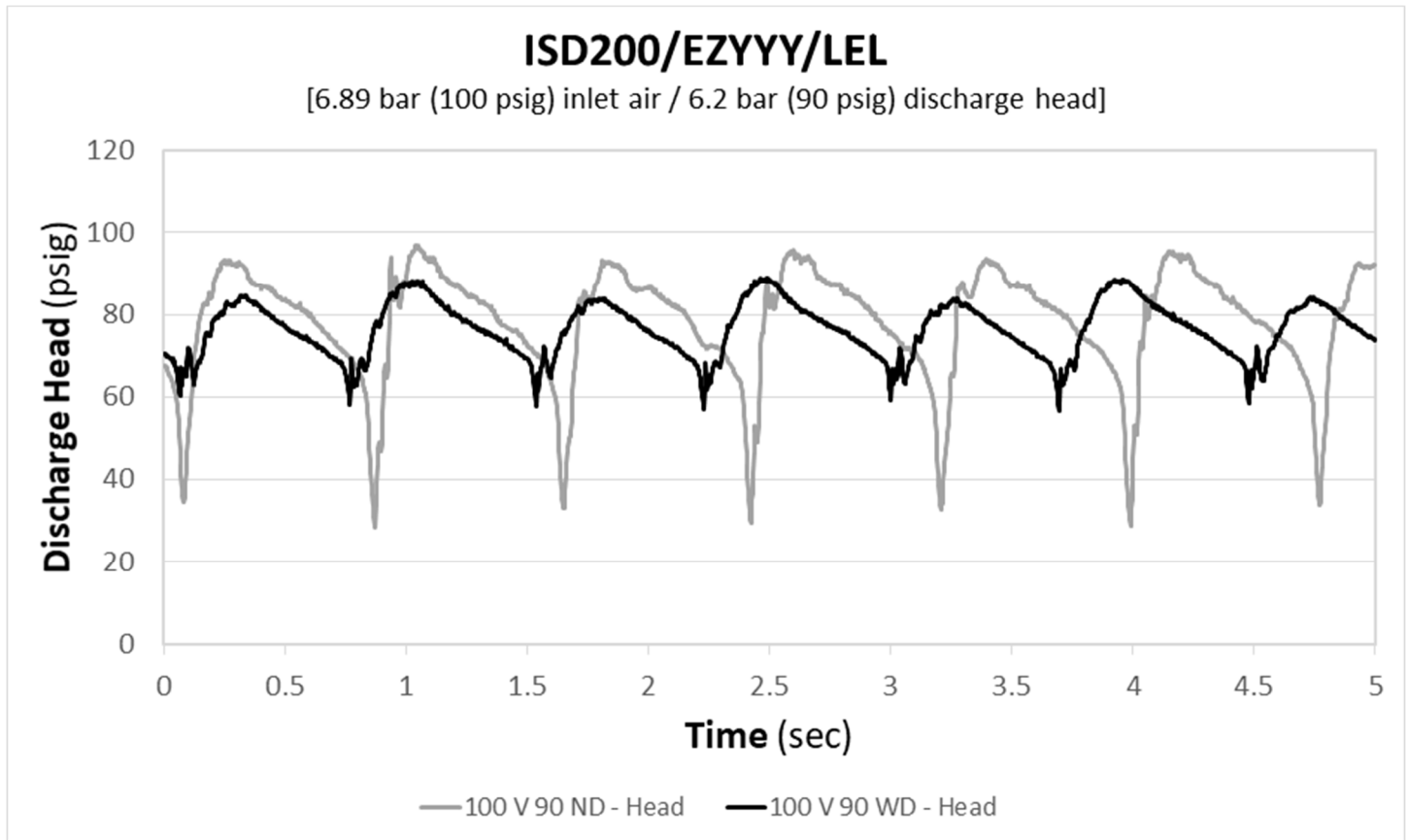

This chart shows discharge head fluctuations for a diaphragm pump with and without a dampener. By reviewing the variation in pressure, the level of dampening can be estimated for an application. For example, the head pressure generated by a 25 mm (1") pump operating at 6.89 bar (100 psig) air inlet pressure and 6.2 bar (90 psig) head pressure varies between 1.9 bar (28 psig) and 6.6 bar (97 psig) resulting in a total pressure fluctuation of 4.7 bar (69 psig) for each stroke. When an ISD200/EZYYY/LEL dampener is installed in the application, the head pressure varies between 6.1 bar (89 psig) and 3.9 bar (56 psig) resulting in a pressure fluctuation of only 2.3 bar (33 psig).

SUGGESTED INSTALLATION, OPERATION & MAINTENANCE

Wilden Equalizer Surge Dampeners minimize pulsation and protects in-line equipment. Integrated SD Series (ISD) dampeners install directly on top of the pump. Model ISD100 is sized 13 mm (1/2") and model ISD200 is sized at 25 mm (1"). The dampeners are designed to fit 13 mm (1/2") and 25 mm (1") Wilden bolted plastic pumps.

INSTALLATION: Before installing an ISD dampener into operation, review cautions and warnings as well as ensure that the materials of construction are suitable for the application. Refer to Wilden's Chemical Resistance Guide for more information.

When installing an ISD dampener in a new Wilden pump, remove the plug from center port of the discharge manifold on the pump. Place ISD dampener in the center port and screw into the thread by hand, carefully, until the dampener is in contact with the pump. Do not over tighten as thread damage can occur. Do not use any thread seal for installation as thread damage could occur. If installing an ISD dampener in a Wilden pump that is already in operation, be sure to remove the pump from service and thoroughly clean it prior to installation.

When installing the pump and dampener in service, remove the yellow blind pugs out of the air inlet located on the top of the dampener head.

OPERATION: Before putting the pulsating dampener into operation, the housing bolts should be tightened as elements of construction tend to "settle".

This illustration is a generic representation of an air-operated double-diaphragm pump.

For correct operation, the dampener will require its own air-supply line, taken from the air supply-of the pump. The pump and dampener are required to be connected to the same air pressure. Note that stop or regulating valves may be placed between the pump and dampener. The driving air has to be oil-free, dry and clean. The dampener requires a minimum counter pressure of at least 1 bar (14.5 psig) for optimal function. At startup, run the pump and dampener slowly prior to full operation. Once adjusted and full of fluid, the dampener self-regulates for all changing operating conditions.

It is recommended to tighten housing bolts after a few hours of operation as well. Fixing bolts is necessary as well after long periods of stoppage, extreme temperature variations, or transport/dismantling.

CAUTION: DO NOT EXCEED 7 BAR (100 PSIG) AIR SUPPLY PRESSURE.

NOTE: In the event of a power failure, the shut-off valve should be closed, if the restarting of the pump is not desirable once power is regained.

MAINTENANCE: When pump disassembly is required, before starting to disassemble the pump, disconnect both the pump and the dampener from service. Thoroughly empty and clean both the pump and dampener before disassembly. Once maintenance is complete, refer to installation guidance prior to putting the pump and dampener back into service.

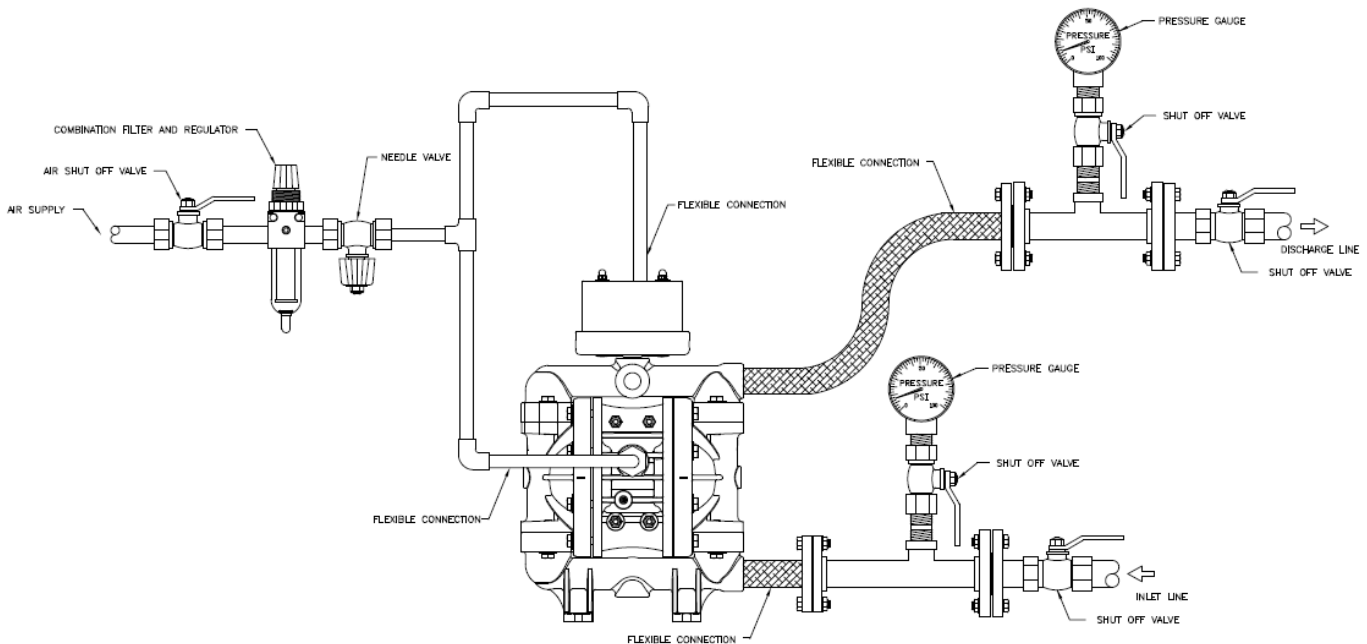

TROUBLESHOOTING

Pump will not run or runs slowly.

1. Ensure that the air inlet pressure is at least 0.4 bar (5 psig) above startup pressure and that the differential pressure (the difference between air inlet and liquid discharge pressures) is not less than 0.7 bar (10 psig).
2. Check air inlet filter for debris (see SUGGESTED INSTALLATION).
3. Check for extreme air leakage (blow by) that would indicate worn seals/bores in the air valve, pilot spool and main shaft.
4. Disassemble pump and check for obstructions in the air passageways or objects that would obstruct the movement of internal parts.
5. Check for sticking ball check valves. If material being pumped is not compatible with pump elastomers, swelling may occur. Replace ball check valves and seals with proper elastomers. Also, as the check valve balls wear out, they become smaller and can become stuck in the seats. In this case, replace balls and seats.
6. Check for broken inner piston that would cause the air valve spool to be unable to shift.
7. Remove plug from pilot spool exhaust.

Pump runs but little or no product flows.

1. Check for pump cavitation; slow pump speed down to allow thick material to flow into liquid chambers.
2. Verify that vacuum required to lift liquid is not greater than the vapor pressure of the material being pumped (cavitation).
3. Check for sticking ball check valves. If material being pumped is not compatible with pump elastomers, swelling may occur. Replace ball check valves and seats with proper elastomers. Also, as the check valve balls wear out, they become smaller and can become stuck in the seats. In this case, replace balls and seats.

Pump air valve freezes.

1. Check for excessive moisture in compressed air. Either install a dryer or hot air generator for compressed air. Alternatively, a coalescing filter may be used to remove the water from the compressed air in some applications.

Air bubbles in pump discharge.

1. Check for ruptured diaphragm.
2. Check tightness of outer pistons (refer to Section 7).
3. Check tightness of fasteners and integrity of O-rings and seals, especially at intake manifold.
4. Ensure pipe connections are airtight.

Product comes out air exhaust.

1. Check for diaphragm rupture.
2. Check tightness of outer pistons to shaft.

WARRANTY

To register your warranty, go to <https://www.psgdover.com/wilden/support/warranty-registration>.

WILDEN[®]

PSG

22069 Van Buren Street

Grand Terrace, CA 92313-5651 USA

P: +1 (909) 422-1730 • F: +1 (909) 783-3440

psgdover.com



Where Innovation Flows

Order Online: www.PumpCatalog.com