

# D SERIES PUMPS

Cleaning / Sanitizing Solution Pumps for CIP & COP Systems  
Efficient Performance – Quiet Operation – Longer Seal Life



Questions? Call **1-800-810-1053**

## TIRED OF CIP RETURN PROBLEMS?

Ampco's DC2 Series has set the standard for CIP supply pumps for over 25 years. The D Series is an affordable solution to your CIP return problems.

The D Series line of pumps is designed primarily for pumping cleaning and sanitizing solutions for the dairy, food, and pharmaceutical industries.

The DV double volute design is available and reduces air binding without an air relief valve.

## FEATURES

- Double volute design is available to reduce air binding
- Optional mechanical seal material
- Enclosed impeller design
- Surface finish better than ACI SIS #1
- Allowable working pressure to 125 psi
- Temperatures to 400° F
- Close coupled to NEMA standard JM motors
- One Week Delivery



The DV Series, with a unique double volute design, is ideally suited for CIP return applications. The double volute design reduces air binding without an air relief valve at half the cost of a self-priming pump.

**Ampco Pumps are manufactured, assembled and tested in Glendale, Wisconsin.**

Ampco Pumps Company  
2045 W. Mill Road  
Glendale, WI 53209  
Phone: 800-737-8671  
sales@ampcopumps.com



www.ampcopumps.com

Ampco Pumps GmbH  
Gewerbepark West II 7  
76863 Herxheim Germany  
Phone: +49 7276 5058515  
info@ampcopumps.de

# AMPCO D SERIES

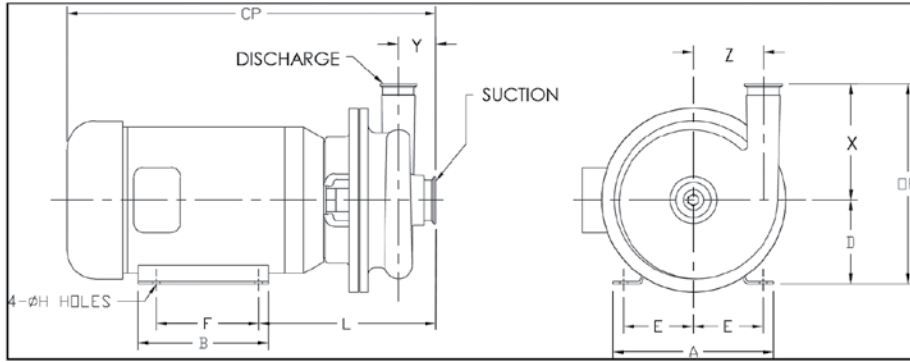

PUMP	MOTOR			DIMENSIONS IN INCHES (not certified for construction)												
	HP	RPM	FRAME	A (max)	B (max)	D	E	F	H	L	CP	OP	X	Y	Z	
2 1/2 x 2	1 1/2 & 2	1750	145JM	6-1/2	6	3-1/2	2-3/4	5	11/32	10-3/4	19	9-3/4	6-1/4	3-11/16	4	
	5	3500	184JM	8-5/8	6-1/2	4-1/2	3-3/4	5-1/2	13/32	11-3/8	21-3/4	10-3/4				
	7 1/2	3500	213JM	9-5/8	8-1/8	5-1/4	4-1/4	5-1/2	13/32	12-3/8	24-5/8	11-1/2				
	10	3500	215JM	9-5/8	8-1/8	5-1/4	4-1/4	7	13/32	12-3/8	24-5/8	11-1/2				
	15 <sup>2</sup>	3500	215JM	9-1/2	8	5-1/4	4-1/4	7	13/32	12-3/8	24-1/2	11-1/2				
3 x 2 1/2	2	1750	145JM	6-1/2	6	3-1/2	2-3/4	5	11/32	11-1/8	19-1/2	9-3/4	6-1/4	3-13/16	4-1/4	
	3	1750	182JM	8-5/8	6-1/2	4-1/2	3-3/4	4-1/2	13/32	11-3/4	20-7/8	10-3/4				
	5	3500	184JM	8-5/8	6-1/2	4-1/2	3-3/4	5-1/2	13/32	11-3/4	22-1/4	10-3/4				
	10	3500	215JM	9-5/8	8-1/8	5-1/4	4-1/4	7	13/32	12-5/8	25-1/8	11-1/2				
	15	3500	254JM	11-1/2	9-3/4	6-1/4	5	8-1/4	17/32	14-1/4	27-1/8	12-1/2				
	20	3500	256JM	11-1/2	11-1/2	6-1/4	5	10	17/32	14-1/4	28-7/8	12-1/2				
3 x 3	2	1750	145JM	6-1/2	6	3-1/2	2-3/4	5	11/32	11-1/4	19/35	10-19/32	7-3/32	4-29/32	5-1/4	
	3	1750	182JM	8-5/8	6-1/2	4-1/2	3-3/4	4-1/2	13/32	11-7/8	21-3/5	11-19/32				
	5	1750	184JM	8-5/8	6-1/2	4-1/2	3-3/4	5-1/2	13/32	11-7/8	22-1/2	11-19/32				
	20	3500	256JM	11-1/2	11-1/2	6-1/4	5	10	17/32	14-1/2	29	13-11/32				
	25	3500	284JM	12-3/4	12-3/4	7	5-1/2	9-1/2	17/32	14-1/2	32-6/7	14-3/32				
	30	3500	286JM	12-3/4	12-3/4	7	5-1/2	11	17/32	14-1/2	32-6/7	14-3/32				
4 x 3	3	1750	182JM	8-5/8	6-1/2	4-1/2	3-3/4	4-1/2	13/32	11-7/8	20-7/8	10-3/4	6-1/4	4-1/4	4-1/4	
	5	1750	184JM	8-5/8	6-1/2	4-1/2	3-3/4	5-1/2	13/32	11-7/8	22-3/8	10-3/4				
	15	3500	254JM	11-1/2	9-3/4	6-1/4	5	8-1/4	17/32	14-3/8	27-1/8	12-1/2				
	20	3500	256JM	11-1/2	11-1/2	6-1/4	5	10	17/32	14-3/8	28-7/8	12-1/2				
	25	3500	284JM	12-3/4	12-3/4	7	5-1/2	9-1/2	17/32	14-3/8	32-3/4	13-1/4				
	30	3500	286JM	12-3/4	12-3/4	7	5-1/2	11	17/32	14-3/8	32-3/4	13-1/4				

<sup>2</sup> Rolled steel motor used

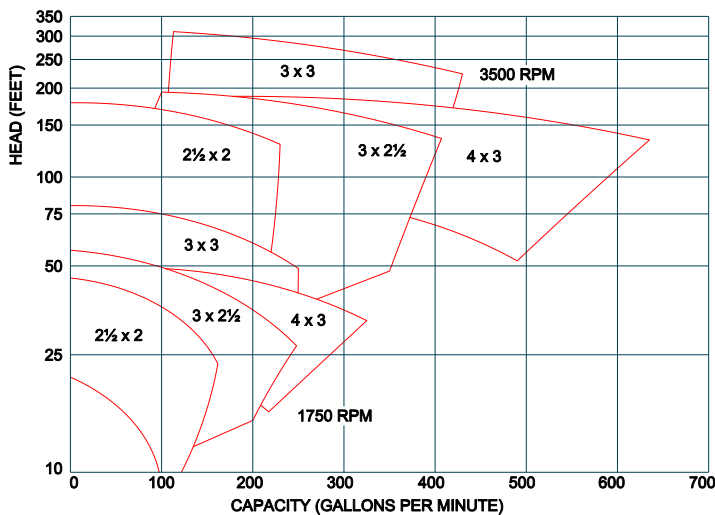

**Ampco Pumps  
Company**



Order Online: [www.PumpCatalog.com](http://www.PumpCatalog.com)