

# **BALDOR**® • *RELIANCE*

## Product Information Packet

# CDPSWD3545

1HP,1750RPM,DC,56C,3536P,TEFC,F1

Part Detail							
Revision:	Q	Status:	PRD/A	Change #:		Proprietary:	No
Type:	DC	Prod. Type:		Elec. Spec:	35WGZ235	CD Diagram:	CD0194
Enclosure:	TEFC	Mfg Plant:		Mech. Spec:	35P634	Layout:	35LYP634
Frame:	56C	Mounting:	F1	Poles:	///	Created Date:	
Base:	RG	Rotation:	R	Insulation:	F	Eff. Date:	09-19-2016
Field Type:		Literature:		Elec. Diagram:		Replaced By:	

Nameplate NP1502	
CAT.NO.	CDPSWD3545
SPEC.	35P634Z235G1
HP	1
RPM	1750
FRAME	56C
ARM V	90
FLD V	
INSUL	F
DUTY	CONT
BRG/DE	6205
BRUSHES	2/BP5000T15
SER.	
BLANK	
APRV-CSA	

ENCL	TEFC
TYPE	3536P
ARM A	9.6
FLD A	
AMB.	40
SUPPLY	K
BRG/ODE	6205
BLANK	
APRV-UL	

Parts List		
Part Number	Description	Quantity
SA018057	SA 35P634Z235G1	1.000 EA
AA003828	AA 35P634Z235G1	1.000 EA
BP5000T15SP	CARBON BRUSH-35P,180VOLTS	1.000 EA
11XW1032G06	10-32 X .38, TAPTITE II, HEX WSHR SLTD U	1.000 EA
HW3001B01	BRASS CUP WASHER, FOR #8 SCREW	1.000 EA
35EP3110A25U	PU ENDPLATE, MACH FOR PAINT FREE S/P#9-2	1.000 EA
HW4600B49	SEAL 0.938 X 1.624 X 0.250 SINGLE LIP DB	1.000 EA
HW4600B46	V-RING SLINGER 0.875 X 1.420 X .24 VITON	1.000 EA
11XB1016S06	90286A240 10-16 X 3/8 HX WSH SLT TY B	3.000 EA
BP5201A18	BRUSH HOLDER - WITHOUT CAP & CONN.	2.000 EA
BP4543A01	BRUSH HOLDER CAP, AE-74-SO W/O'RING	2.000 EA
BP3000A02SP	AMP LEAD CLIP #60812-2 SPL	1.000 EA
HW5100A05	WVY WSHR F/205 & 304 BRGS	1.000 EA
35EP3301A10U	PU ENDPLATE, MACH FOR PAINT FREE S/P#9-4	1.000 EA
HW4606A02	JM CLIPPER/SEAL (LWE-0938-1624-AL23)	1.000 EA
12XN1032S20	10-32 X 1-1/4 HEX M.S. , STAINLESS STEEL	2.000 EA
HA1049A01	DUBO LOK WASHER SIZE 10 (NYLON LOCK SEAL	2.000 EA
11XB1016S06	90286A240 10-16 X 3/8 HX WSH SLT TY B	3.000 EA
80XN1032A03	10-32 X 3/16 SET SCREW	2.000 EA
35FN3002A05	EXFN, PLASTIC, 6.376 OD, .638 ID	1.000 EA
51XB1214A16	12-14X1.00 HXWSSLD SERTYB	1.000 EA
35FH4005A39	IEC FH NO GREASER (#304 SS)CLEAN ONLY	1.000 EA
11XW1032S06	10-32 X .38, TAPTITE II, HEX WSHR SLTD U	3.000 EA
WD4102A01	SR-6L-1 HEYCO STRN RELIEF OR 23MPO6L10 M	1.000 EA

<b>Parts List (continued)</b>		
<b>Part Number</b>	<b>Description</b>	<b>Quantity</b>
WD4100A17	PLUG STIMPSON D4036	1.000 EA
35CB4506A02	CONDUIT BOX LID, STAMPED #304 SS FINISH	1.000 EA
35GS1010A01	GASKET, CONDUIT BOX LID TDR 11640	1.000 EA
59XW0832S07	TAPTITE II,HEX WSHR UNSLTD SER,410 S.S.,	2.000 EA
HW2502D13	SS KEY, 3/16 SQ X 1.375	1.000 EA
HA7000A04	KEY RETAINER 0.625 DIA SHAFTS	1.000 EA
LB1164	LABEL,WARNING AND DRAIN	1.000 EA
MJ1000A02	GREASE, POLYREX EM EXXON (USe 4824-15A)	0.001 LB
MJ5001A23	P.D. GEORGE B-276 AIR DRY VARNISH	0.001 GA
MJ5001A02	732 CL SEALANT 3 OZ DIXIE BEARING 289100	0.001 EA
MJ5004A05	#242-21 LOCTITE GENERAL PURPOSE MED. STR	0.001 EA
10XF0440S02	04-40 X 1/8 TYPE F HEX HD STAINLESS STIC	2.000 EA
HA3101S46	THRUBOLT- 1/4-20 X 10.00 SS	4.000 EA
MN416A01	TAG-INSTAL-MAINT no wire (1200/bx) 11/14	1.000 EA
LC0194	CONNECTION LABEL	1.000 EA
NP1502	WASHDOWN NP "DC MOTORS" UL CSA	1.000 EA
35PA1007	PKG GRP, PRINT PK1034A06	1.000 EA

**DC Motor Performance Data**

Record # 390 - Typical performance - not guaranteed values

<b>Winding:</b> 35WGZ235-R003	<b>Type:</b> 3536P	<b>Enclosure:</b> TEFC
-------------------------------	--------------------	------------------------

Nameplate Data		General Characteristics	
Rated Output (HP)	1	Armature Resistance @ 25°C	0.245 Ω
R.P.M.	1750		
Armature Volts	90		
Armature Amps	9.6		
Field Volts		Armature Inductance	3.789 mH
Field Amps			
Rating - Duty	40C AMB-CONT		
Power Supply Code	K		

Load Characteristics at 90 Armature Volts

Load Point	1	2	3	4	5	6	7
Armature Amps	1	3.3	4.5	8	10.1	12.3	14.8
R.P.M.	1930	1926	1919	1865	1850	1756	1745
Torque ( LB-FT )	0	0.75	1.15	2.25	3	3.75	4.5

Performance Graph at 90.0 Arm V, 1.0HP Typical performance - Not guaranteed values

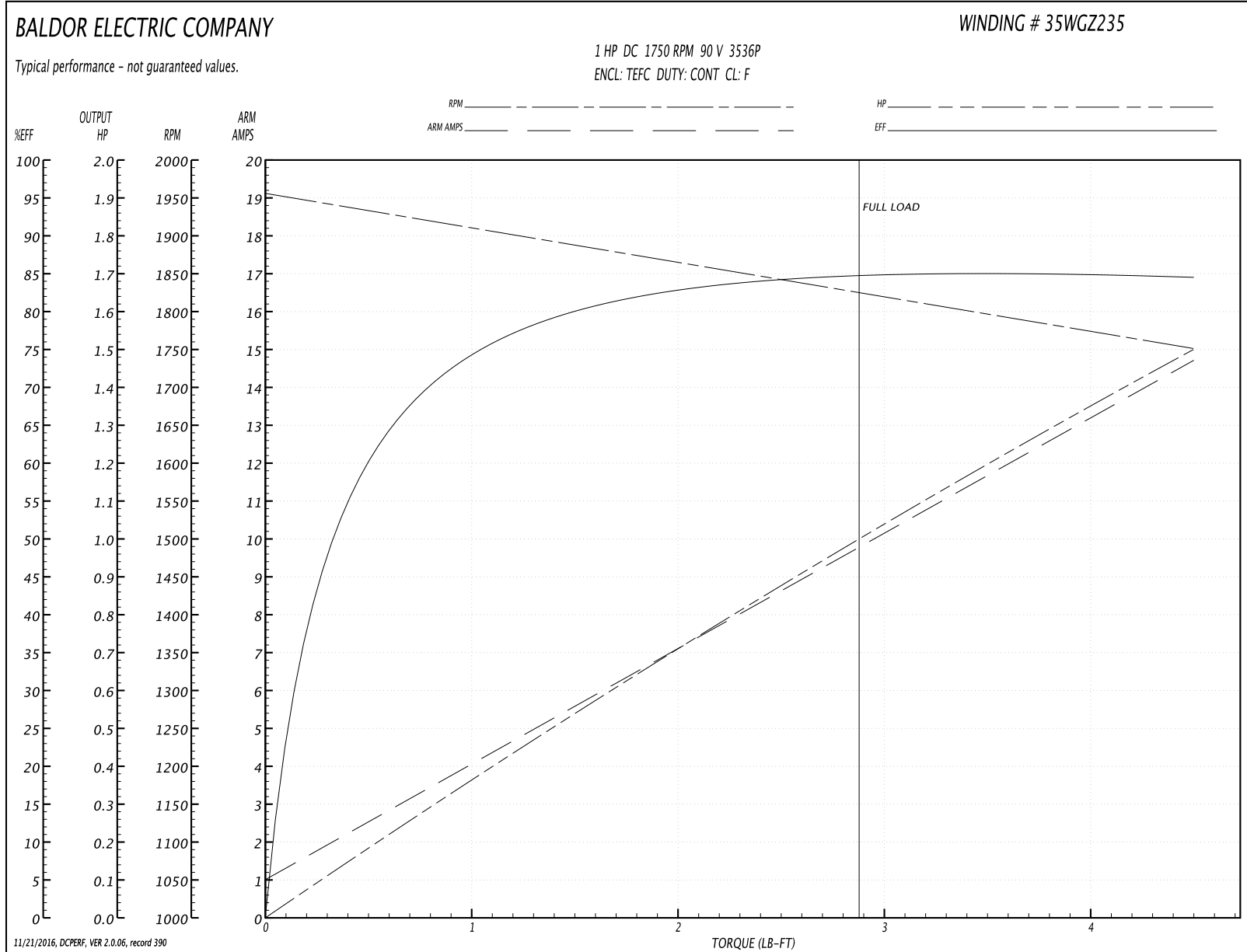

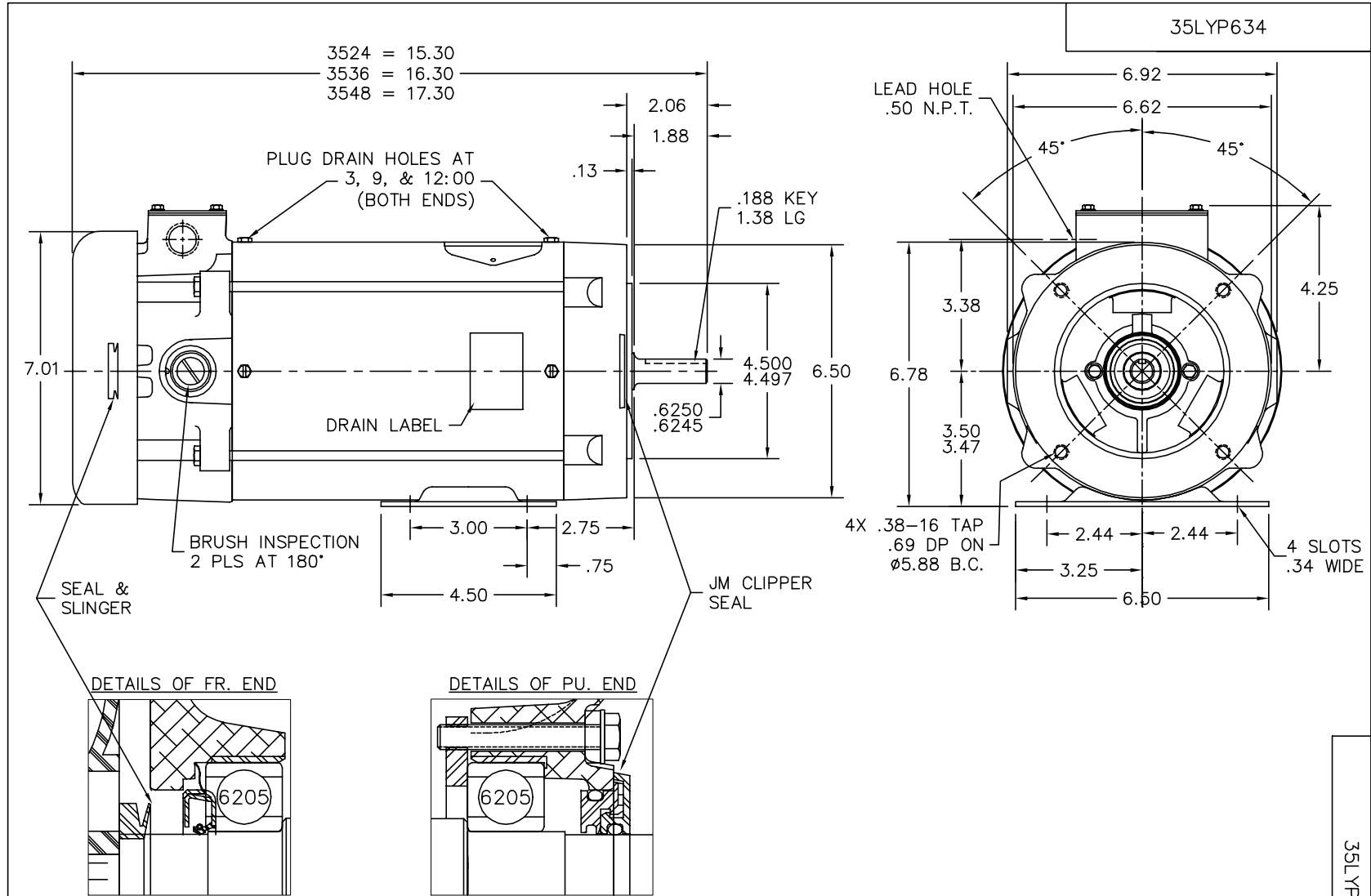

CUSTOMER IS RESPONSIBLE FOR DETERMINING THAT BALDOR'S PRODUCT WILL PERFORM SUITABLY IN THE INTENDED APPLICATION.

REV. DESC: IN DESCRIPTION S/P9-2 WAS S/P9-4		
REV. LTR: E	VERSION: 02	TDR: 000000789549
FILE: \AAA\00043\269		REVISED: 03:16:11 03/08/2013
MTL: -		BY: ENTROEO

<b>BALDOR</b>
STD HORZ 35PM TEFC NEMA 56C PAINT FREE (S/P 9-2)
SH 1 of 1

35LYP634



CD0194

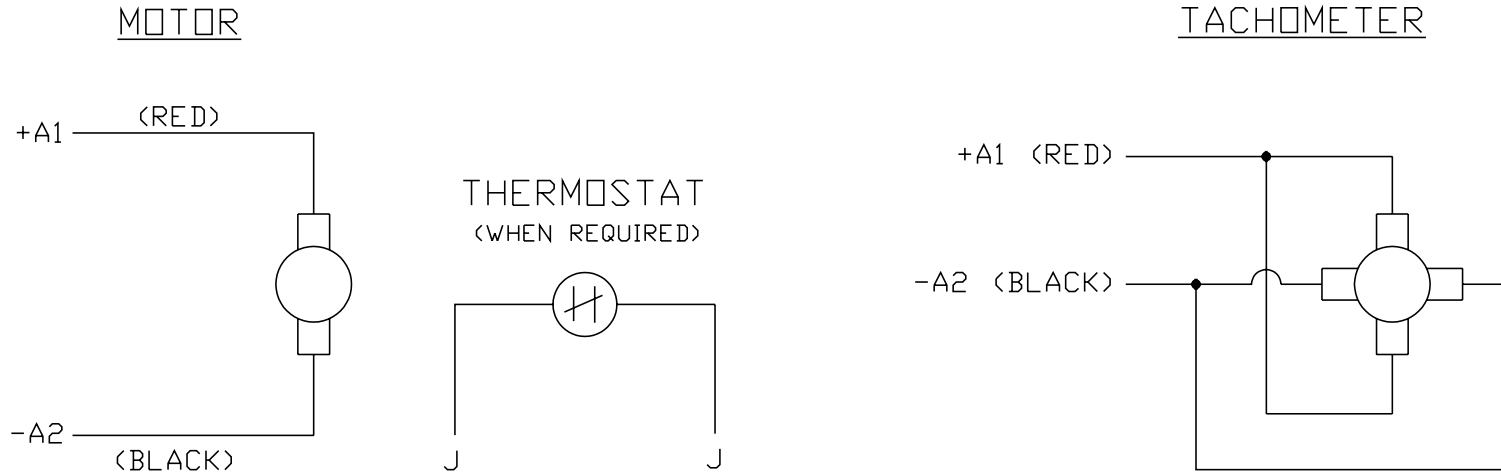

NOTES:

1. CCW ROTATION AS SHOWN FACING COMMUTATOR END. TO REVERSE MOTOR ROTATION OR TACHOMETER OUTPUT POLARITY INTERCHANGE LEADS A1(RED) & A2(BLACK)
2. LEAD COLORS FOR REFERENCE ONLY & NOT SPECIFIED BY THIS DRAWING. LEAD COLORS SPECIFIED BY LAYOUT DRAWING & BILL OF MATERIAL ONLY.

MATL: -			
REV: E	ADDED NOTE "LEAD COLORS FOR REFERENCE ONLY &..."		
CD0194	SCALE: -	BY: CK	REVISED: 07/28/95
	FILE: AAA00004503	TDR: 0078737	

**BALDOR ELECTRIC Co.**

CD TYPE P DC PERMANENT MAGNET MOTORS AND TACHOMETERS

CD0194