

# **BALDOR® • RELIANCE**

## **Product Information Packet**

# **EJMM2543T**

**50HP, 1775RPM, 3PH, 60HZ, 326JM, 4256M, OPSB, F**

Part Detail							
Revision:	T	Status:	PRD/A	Change #:		Proprietary:	No
Type:	AC	Prod. Type:	4256M	Elec. Spec:	42WGW387	CD Diagram:	CD0180
Enclosure:	OPSB	Mfg Plant:		Mech. Spec:	42F59	Layout:	42LYF059
Frame:	326JM	Mounting:	F1	Poles:	04	Created Date:	
Base:	RG	Rotation:	R	Insulation:	F	Eff. Date:	04-06-2016
Leads:	9#8					Replaced By:	
Literature:		Elec. Diagram:					

Nameplate NP2138L											
CAT.NO.	EJMM2543T			P/N				ENCLOSURE	OPSB		
SPEC.	42F059W387G4		CC	010A	FRAME	326JM		S/N			
HP	50			CLASS	F	HZ	60				
RPM	1775		PH	3	DES	A					
VOLT	230/460				KVA-CODE	G		ODE BRG	6311	DE BRG	6312
AMP	114/57			USABLE AT 208V	121						
RATING	40C AMB-CONT			GREASE	POLYREX EM						
NEMA-NOM-EFF	94.5	PF	87	SER.F.	1.15						
HTR-VOLTS			HTR-AMPS			MAX. SPACE HEATER TEMP.					

Parts List		
Part Number	Description	Quantity
SA111841	SA 42F059W387G4	1.000 EA
RA103154	RA 42F059W387G4	1.000 EA
S/P107-000-004	SUPER-E(284 FR. & UP)-CL PLANT,POLYREX E	1.000 EA
HA6360	LIFTING LUG FOR 42 FRAME MOTORS.	2.000 EA
HA6017	CAST ADAPTER, 40,42 KOBX	1.000 EA
19XW3118A12	.31-18 X .75 HEX WASHER HEAD TAPTITE II	2.000 EA
HW1001A31	LOCKWASHER 5/16, ZINC PLT.591 OD, .319 I	2.000 EA
10CB3001	CONDUIT BOX CAST W/2.500 LEAD HOLE	1.000 EA
19XW3118A12	.31-18 X .75 HEX WASHER HEAD TAPTITE II	4.000 EA
HW1001A31	LOCKWASHER 5/16, ZINC PLT.591 OD, .319 I	4.000 EA
WD1000B16	T&B CX70TN TERMINAL	1.000 EA
51XF2520A08	SCREW, HEX SER SLT HD, ZN 1/4-20 X .50 L	1.000 EA
42EP3200A01	FR ENDPLATE, MACH 324-6T	1.000 EA
HA1108A01	RODENT SCREEN	1.000 EA
HA4051A00	PLASTIC CAP FOR GREASE FITTING	1.000 EA
51XW1032A06	10-32 X .38, TAPTITE II, HEX WSHR SLTD S	4.000 EA
HW5100A13	W4627-047 WVY WSHER	1.000 EA
42EP1300A16	PU ENDPLATE, MACH	1.000 EA
HA4051A00	PLASTIC CAP FOR GREASE FITTING	1.000 EA
HA1165A01	RODENT SCREEN FOR 42 PU. C-FACE EP (INSI	1.000 EA
51XW1032A06	10-32 X .38, TAPTITE II, HEX WSHR SLTD S	4.000 EA
10XN3118K40	5/16-18 X 2.50" HEX HD, GRADE 5	4.000 EA
HW1001A31	LOCKWASHER 5/16, ZINC PLT.591 OD, .319 I	4.000 EA
XY5013A12	NUT,1/2-13,HEX,STEEL,ZINCPLATED	8.000 EA

<b>Parts List (continued)</b>		
<b>Part Number</b>	<b>Description</b>	<b>Quantity</b>
10CB3500SP	CONDUIT BOX LID, CAST	1.000 EA
51XW2520A12	.25-20 X .75, TAPTITE II, HEX WSHR SLTD	4.000 EA
HW4600B41	V-RING SLINGER 2.125 X 2.880 X 0.280	1.000 EA
HW2501E22	KEY, 1/4 SQ X 2.500	1.000 EA
LB1115N	LABEL,LIFTING DEVICE (ON ROLLS)	1.000 EA
MN416A01	TAG-INSTAL-MAINT no wire (1000/bx) 11/14	1.000 EA
HW4500A03	GREASE FITTING, .125 NPT 1610(ALEMITE) 8	1.000 EA
HW4500A17	317400 ALEMITE GREASE RELIEF	1.000 EA
MJ1000A02	GREASE, POLYREX EM EXXON (USe 4824-15A)	0.030 LB
HW4500A03	GREASE FITTING, .125 NPT 1610(ALEMITE) 8	1.000 EA
HW4500A17	317400 ALEMITE GREASE RELIEF	1.000 EA
MG1000Y03	MUNSELL 2.53Y 6.70/ 4.60, GLOSS 20,	0.080 GA
85XU0407S04	4X1/4 U DRIVE PIN STAINLESS	4.000 EA
42AD2001A01	BAFFLE PLATE 42 OPEN, SLOTTED BAND MTRS	1.000 EA
42AD2001A01	BAFFLE PLATE 42 OPEN, SLOTTED BAND MTRS	1.000 EA
HA3151A03	THRUBOLT STUD 1/2-13 X 20.5	4.000 EA
LB1119N	WARNING LABEL	1.000 EA
LC0181	CONNECTION LABEL	1.000 EA
NP2138L	ALUM SUPER-E UL CSA-EEV PREM CC (300	1.000 EA
42PA1000	PACKAGING GROUP PRINT PK1024A06	1.000 EA

**AC Induction Motor Performance Data**

Record # 53755 - Typical performance - not guaranteed values

<b>Winding:</b> 42WGW387-R001	<b>Type:</b> 4256M	<b>Enclosure:</b> OPSB
-------------------------------	--------------------	------------------------

Nameplate Data				460 V, 60 Hz: High Voltage Connection	
Rated Output (HP)	50			Full Load Torque	149 LB-FT
Volts	230/460			Start Configuration	direct on line
Full Load Amps	114/57			Breakdown Torque	420 LB-FT
R.P.M.	1775			Pull-up Torque	217 LB-FT
Hz	60	Phase	3	Locked-rotor Torque	311 LB-FT
NEMA Design Code	B	KVA Code	G	Starting Current	373 A
Service Factor (S.F.)	1.15			No-load Current	20.2 A
NEMA Nom. Eff.	94.5	Power Factor	87	Line-line Res. @ 25°C	0.12266 Ω
Rating - Duty	40C AMB-CONT			Temp. Rise @ Rated Load	39°C
S.F. Amps				Temp. Rise @ S.F. Load	47°C

Load Characteristics 460 V, 60 Hz, 50 HP

% of Rated Load	25	50	75	100	125	150	S.F.
Power Factor	54	75	83	87	88	88	88
Efficiency	92	94.5	94.9	94.7	94.2	93.4	94.4
Speed	1791	1786.1	1781.1	1775.2	1769.2	1762.1	1772
Line amperes	24.4	33.4	44.7	57.4	71	85.6	65.6

Performance Graph at 460V, 60Hz, 50.0HP Typical performance - Not guaranteed values

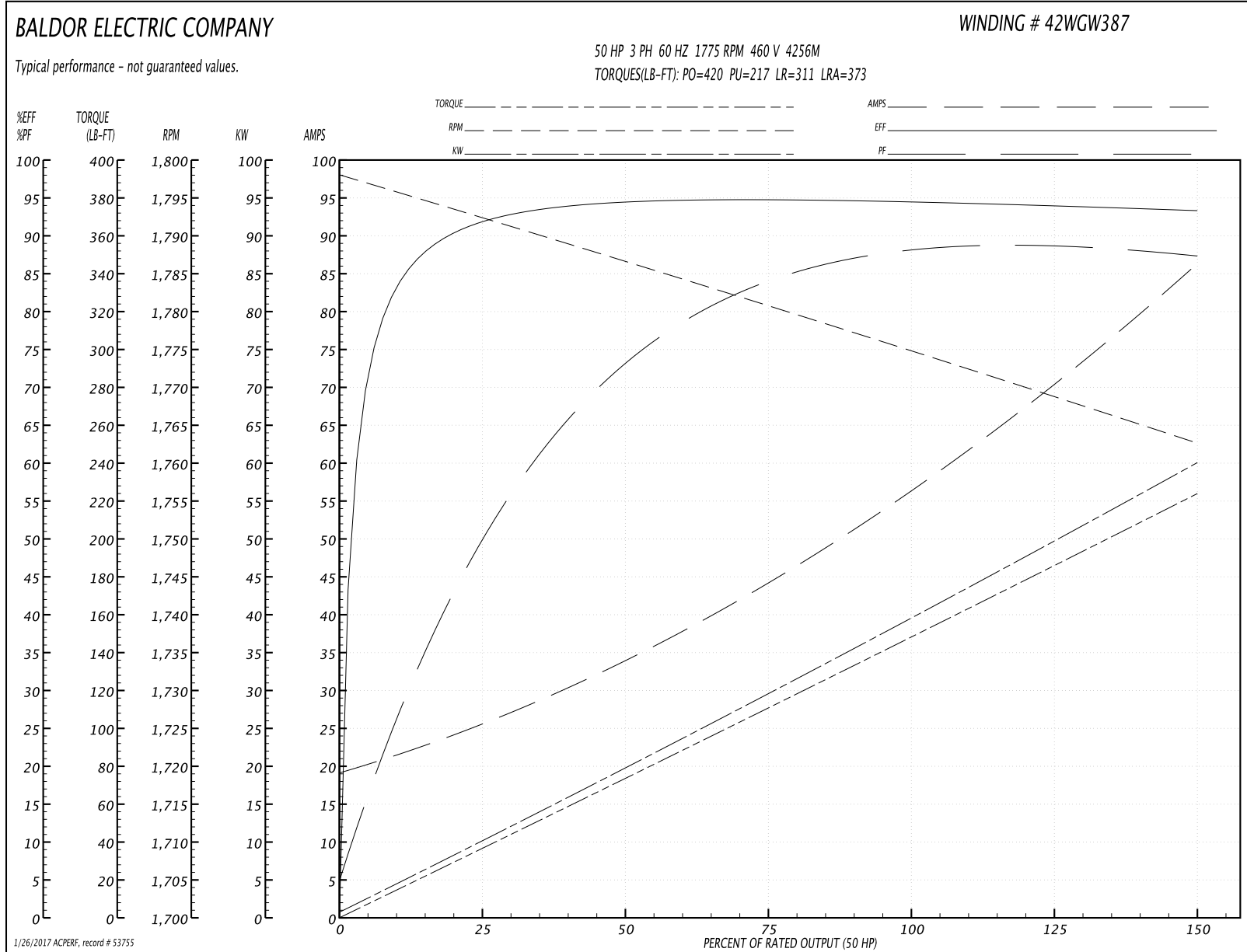

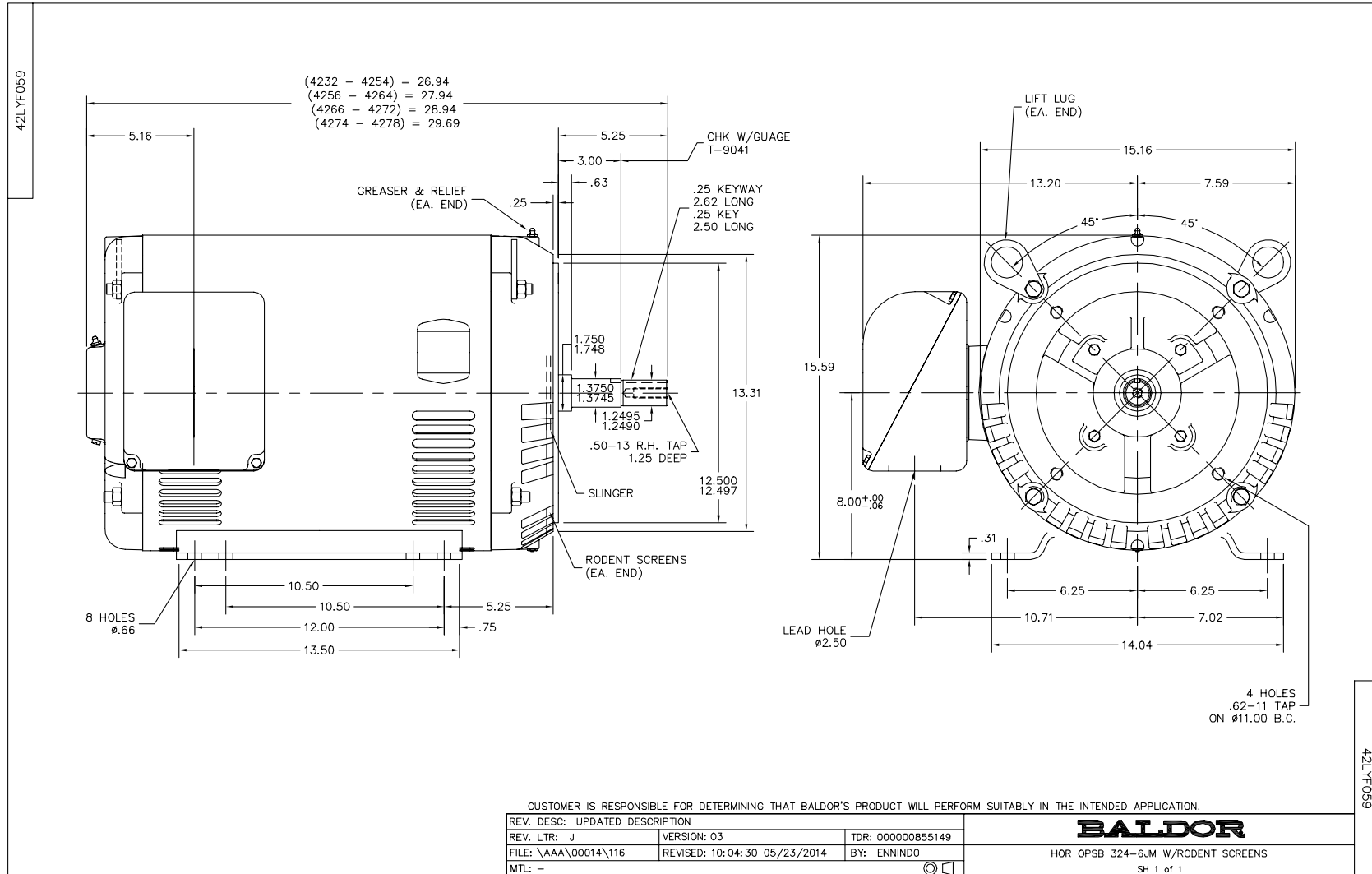

CD0180



LOW VOLTAGE  
(2D)



LINE

HIGH VOLTAGE  
(1D)

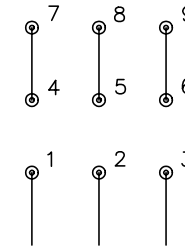

LINE

NOTES:

1. INTERCHANGE ANY TWO LINE LEADS TO REVERSE ROTATION.
2. OPTIONAL THERMOSTATS ARE PROVIDED WHEN SPECIFIED.
3. ACTUAL NUMBER OF INTERNAL PARALLEL CIRCUITS MAY BE A MULTIPLE OF THOSE SHOWN ABOVE.
4. LEAD COLORS ARE OPTIONAL. LEADS MUST ALWAYS BE NUMBERED AS SHOWN.

REV. DESC: REVISE TO SHOW OPTIONAL COLORS			
REV. LTR: C	BY: JLP	REVISED: 01/21/99 2:28	TDR: 0171435
0810D0		FILE: AAA00005148	MDL: -
		MTL: -	

**BALDOR ELECTRIC Co.**

3PH, DV, 9 LEADS, DELTA CONNECTION

CD0180