

BALDOR® • ***RELIANCE***

Product Information Packet

EJMM3211T

3HP,1765RPM,3PH,60HZ,182JM,3630M,OPSB,F1

Part Detail							
Revision:	E	Status:	PRD/A	Change #:		Proprietary:	No
Type:	AC	Prod. Type:	3630M	Elec. Spec:	36WGS658	CD Diagram:	CD0005
Enclosure:	OPSB	Mfg Plant:		Mech. Spec:	36G687	Layout:	36LYG687
Frame:	182JM	Mounting:	F1	Poles:	04	Created Date:	06-01-2011
Base:	RG	Rotation:	R	Insulation:	F	Eff. Date:	11-07-2016
Leads:	9#16					Replaced By:	
Literature:		Elec. Diagram:					

Nameplate NP1259L													
CAT.NO.	EJMM3211T												
SPEC.	36G687S658G1												
HP	3												
VOLTS	230/460												
AMP	8.4/4.2												
RPM	1765												
FRAME	182JM					HZ	60			PH	3		
SER.F.	1.15					CODE	K		DES	B		CL	F
NEMA-NOM-EFF	89.5					PF	74						
RATING	40C AMB-CONT												
CC	010A									USABLE AT 208V	8.5		
DE	6207					ODE	6205						
ENCL	OPSB					SN							

Parts List		
Part Number	Description	Quantity
SA224435	SA 36G687S658G1	1.000 EA
RA211546	RA 36G687S658G1	1.000 EA
36CB3004	36 CB CASTING W/1.09 DIA LEAD HOLE @ 6:0	1.000 EA
51XB1016A08	10-16X 1/2HXWSSLD SERTYB	2.000 EA
11XW1032G06	10-32 X .38, TAPTITE II, HEX WSHR SLTD U	1.000 EA
HW3001B01	BRASS CUP WASHER, FOR #8 SCREW	1.000 EA
36FE3200A25	FREP ASSEMBLY FOR ROUTING PURPOSES	1.000 EA
HA1103A08	RODENT SCREEN, 36 FRAME, OPEN, FRONT END	1.000 EA
51XW1032A06	10-32 X .38, TAPTITE II, HEX WSHR SLTD S	4.000 EA
HW1000A10	#10 FLAT WASHER (SAE)	4.000 EA
HW4500A01	1641B(ALEMITE)400 UNIV, GREASE FITT	1.000 EA
HW4500A17	317400 ALEMITE GREASE RELIEF	1.000 EA
HW5100A05	WVY WSHR F/205 & 304 BRGS	1.000 EA
36PE3405A04	PUEP 182-4C OPEN 207 BRG W/ TSLV, GRGR	1.000 EA
HA1102A07	RODENT SCREEN 36 OPEN FACE	2.000 EA
51XW1032A06	10-32 X .38, TAPTITE II, HEX WSHR SLTD S	4.000 EA
HW1000A10	#10 FLAT WASHER (SAE)	4.000 EA
HW4500A01	1641B(ALEMITE)400 UNIV, GREASE FITT	1.000 EA
HW4500A17	317400 ALEMITE GREASE RELIEF	1.000 EA
10XN2520A24	1/4-20X 1 1/2 HEX HD X	4.000 EA
HW1001A25	LOCKWASHER 1/4, ZINC PLT .493 OD, .255 I	4.000 EA
36CB4516	36 LIPPED CB LID	1.000 EA
51XW0832A07	8-32 X .44, TAPTITE II, HEX WSHR SLTD SE	4.000 EA
HA1005A07	SLINGER, OD 2.25, ID 1.344, 307 BRG	1.000 EA

Parts List (continued)		
Part Number	Description	Quantity
HW2501D13	KEY, 3/16 SQ X 1.375	1.000 EA
HA7000A01	KEY RETAINER 7/8" DIA SHAFT	1.000 EA
85XU0407S04	4X1/4 U DRIVE PIN STAINLESS	2.000 EA
MJ1000A02	GREASE, POLYREX EM EXXON (USe 4824-15A)	0.050 LB
MG1000Y03	MUNSELL 2.53Y 6.70/ 4.60, GLOSS 20,	0.022 GA
HA3101A25	THRUBOLT 1/4-20 X 11.000 OHIO ROD	4.000 EA
36AD2004A01	BAFFLE PLATE,MOD 36-SLTD BAND MTRS DELTA	2.000 EA
LC0005E01	CONN.DIA./WARNING LABEL (LC0005/LB1119N)	1.000 EA
NP1259L	ALUM SUPER-E UL CSA-EEV CC NEMA PREMIUM	1.000 EA
G7PA1000	PKG GRP, PRINT PK1034A06	1.000 EA
MN416A01	TAG-INSTAL-MAINT no wire (1000/bx) 11/14	1.000 EA

AC Induction Motor Performance Data

Record # 33604 - Typical performance - not guaranteed values

Winding: 36WGS658-R001	Type: 3630M	Enclosure: OPSB
-------------------------------	--------------------	------------------------

Nameplate Data				460 V, 60 Hz: High Voltage Connection	
Rated Output (HP)	3			Full Load Torque	8.87 LB-FT
Volts	230/460			Start Configuration	direct on line
Full Load Amps	8.4/4.2			Breakdown Torque	37.4 LB-FT
R.P.M.	1765			Pull-up Torque	17.3 LB-FT
Hz	60	Phase	3	Locked-rotor Torque	21.2 LB-FT
NEMA Design Code	B	KVA Code	K	Starting Current	32.3 A
Service Factor (S.F.)	1.15			No-load Current	2.43 A
NEMA Nom. Eff.	89.5	Power Factor	74	Line-line Res. @ 25°C	3.8716 Ω
Rating - Duty	40C AMB-CONT			Temp. Rise @ Rated Load	24°C
S.F. Amps				Temp. Rise @ S.F. Load	28°C
				Locked-rotor Power Factor	43
				Rotor inertia	0.279 LB-FT ²

Load Characteristics 460 V, 60 Hz, 3 HP

% of Rated Load	25	50	75	100	125	150	S.F.
Power Factor	33	53	66	73	79	81	77
Efficiency	80.2	87.5	89.5	89.7	89.5	88.7	89.6
Speed	1791.1	1783	1774.5	1765.5	1755.7	1744.8	1760
Line amperes	2.6	2.99	3.54	4.25	4.97	5.83	4.68

Performance Graph at 460V, 60Hz, 3.0HP Typical performance - Not guaranteed values

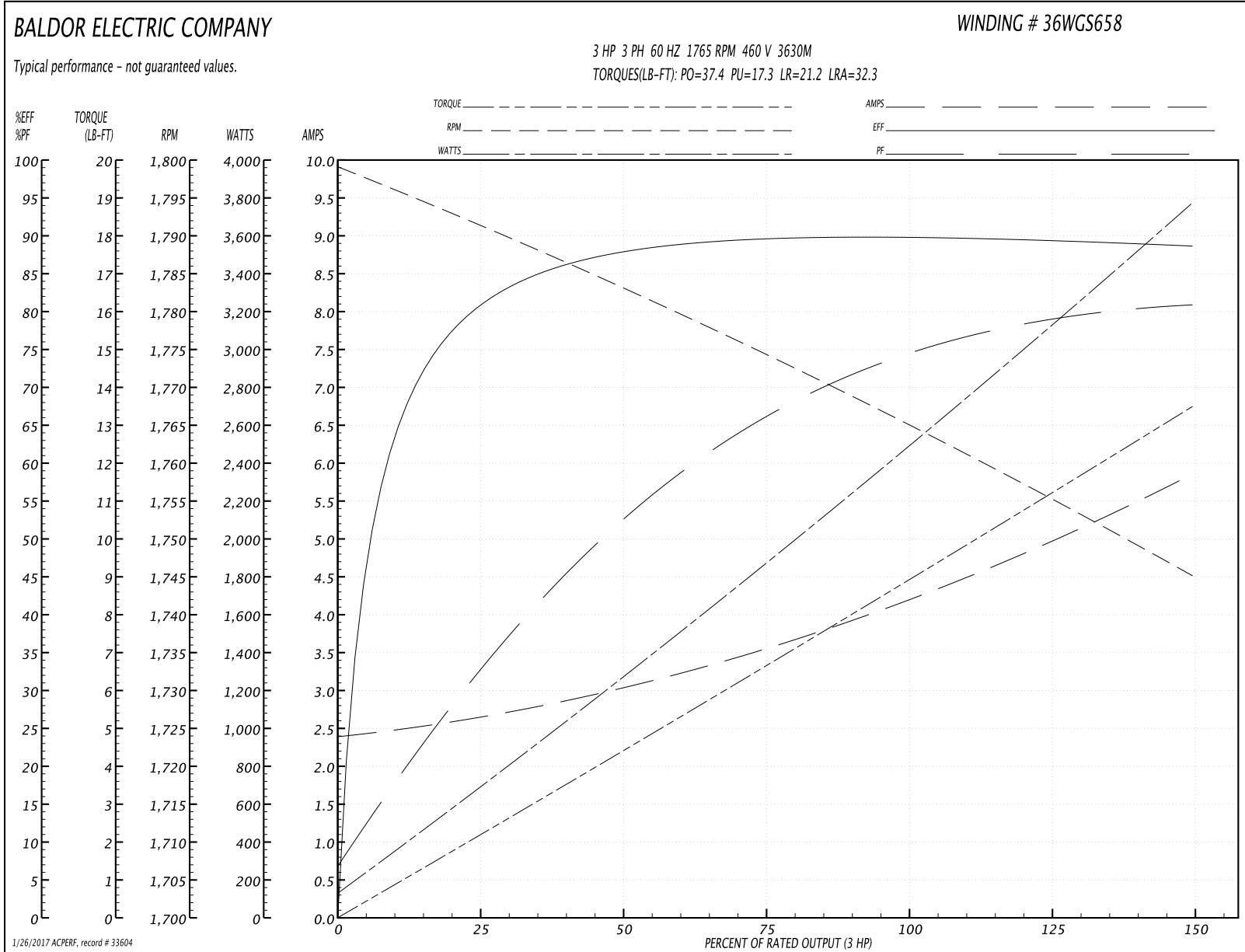

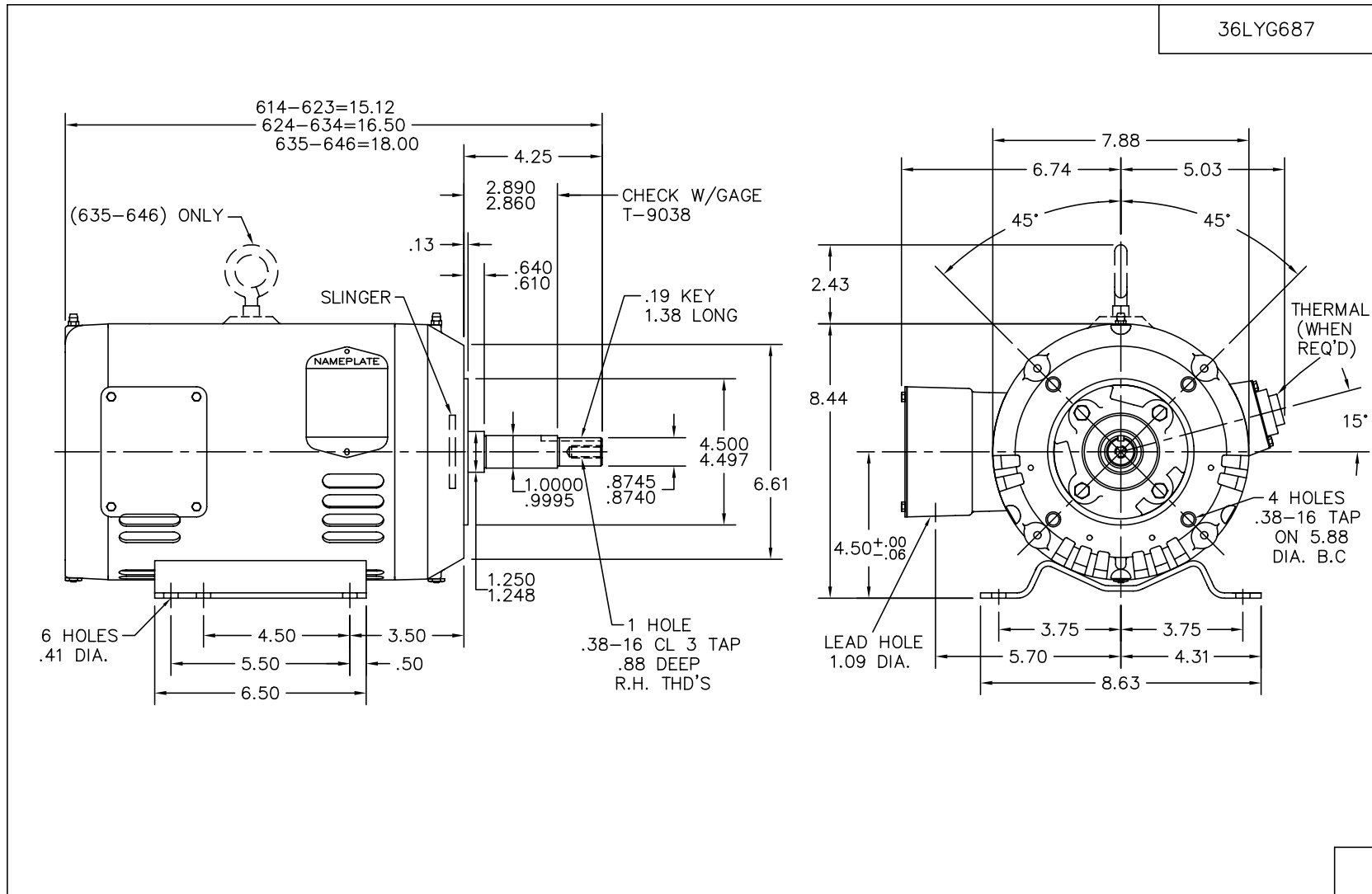

CUST. NAME		CUST. P.O.		CERTIFIED BY		MODEL		INSUL		AMB		
H.P.		MTG		TYPE		R.P.M.		VOLTS		ENCL		
PHASE		FREQ		FRAME		REV. DESC: CHG'D CONDUIT BOX AND LID (SEE EC09)						
REV. LTR: D		BY: JED		REVISED: 02/23/99 8:11		TDR: 0171565						
FILE: AAA00004132		MDL: -						BALDOR ELECTRIC Co. STD HORZ 182-4JM OPSB 36M W/SCREENS				
MTL: -												

36LYG687

CD0005



LOW VOLTAGE
(2Y)



LINE

HIGH VOLTAGE
(1Y)



LINE

NOTES:

1. INTERCHANGE ANY TWO LINE LEADS TO REVERSE ROTATION.
2. OPTIONAL THERMOSTATS ARE PROVIDED WHEN SPECIFIED.
3. ACTUAL NUMBER OF INTERNAL PARALLEL CIRCUITS MAY BE A MULTIPLE OF THOSE SHOWN ABOVE.
4. LEAD COLORS ARE OPTIONAL. LEADS MUST ALWAYS BE NUMBERED AS SHOWN.

REV. DESC: REVISE TO SHOW OPTIONAL COLORS			
REV. LTR: E	BY: JLP	REVISED: 01/19/99 10:15	TDR: 0171435
90000		FILE: AAA00005140	MDL: -
		MTL: -	

BALDOR ELECTRIC Co.

3PH, DV, 9 LEADS

CD0005