

BALDOR® • **RELIANCE**

Product Information Packet

IDXM7544T

5HP,1760RPM,3PH,60HZ,213TC,0728M,XPFC,F1

Part Detail							
Revision:	E	Status:	PRD/A	Change #:		Proprietary:	No
Type:	AC	Prod. Type:	0728M	Elec. Spec:	07WGY967	CD Diagram:	CD0005
Enclosure:	XPFC	Mfg Plant:		Mech. Spec:	07H867	Layout:	07LYH867
Frame:	213TC	Mounting:	F1	Poles:	04	Created Date:	11-16-2012
Base:	RG	Rotation:	R	Insulation:	F	Eff. Date:	07-09-2015
Leads:	9#14					Replaced By:	
Literature:		Elec. Diagram:					

Nameplate NP0890XPSLEV									
NO.					CC	010A			
S/N					TEMP CODE	T2B			
SPEC.	07H867Y967G1				INV. TYPE	PWM			
CAT.NO.	IDX7544T				C HP FR	60		C HP TO	90
HP	5				CT HZ FROM	6		CT HZ TO	60
VOLTS	230/460				VT HZ FROM	6		VT HZ TO	60
AMPS	13.4/6.7				MAG CUR	7/3.5			
RPM	1760				MX RPM	2700			
HZ	60	PH	3	CL	F	NOM.EFF.	90.2		
SER.F.	1.00		DES	B	SL HZ	1.2	WK2	0.69	
FRAME	213TC		RATING	40C AMB-CONT					

Parts List		
Part Number	Description	Quantity
SA254422	SA 07H867Y967G1	1.000 EA
RA241229	RA 07H867Y967G1	1.000 EA
37FN3002C01	EXFN, PLASTIC, 6.00 OD, 1.155 ID	1.000 EA
HA3210E08	.250X 7/8 PIN 312-57	1.000 EA
HW3201A05	3/8-16 EYEBOLT	1.000 EA
07CB1000A01	CONDUIT BOX MACH	1.000 EA
10XN3118A16	5/16-18X1 HEX HD CAP	4.000 EA
HW1001A31	LOCKWASHER 5/16, ZINC PLT .591 OD, .319 I	4.000 EA
11XW1032G06	10-32 X .38, TAPTITE II, HEX WSHR SLTD U	1.000 EA
WD1000B17	T&B CX35TN TERMINAL	1.000 EA
07EP1707A01	STD FRONT ENDPLATE EXPLOSION PROOF	1.000 EA
HW4500A19	1/4-28X1/4 SLOTTED PLUG F/S	2.000 EA
10XN3816K28	3/8-16 X 1.75 HEX HD CAP SCREW, GRADE 5	4.000 EA
HW1001A38	LOCKWASHER 3/8, ZINC PLT .688 OD, .382 I	4.000 EA
HW5100A06	W2420-025 WVY WSHR (WB)	1.000 EA
07EP1708A01	STANDARD FACE MOUNTED ENDPLATE EXPLOSEIO	1.000 EA
HW4500A19	1/4-28X1/4 SLOTTED PLUG F/S	2.000 EA
10XN3816K28	3/8-16 X 1.75 HEX HD CAP SCREW, GRADE 5	4.000 EA
HW1001A38	LOCKWASHER 3/8, ZINC PLT .688 OD, .382 I	4.000 EA
10XN2520A32	1/4 X 2 HEX HEAD CAP SCR, GRADE 2	4.000 EA
HW1001A25	LOCKWASHER 1/4, ZINC PLT .493 OD, .255 I	4.000 EA
07FH1003A01	STANDARD 307 EXPLOSION PROOF FAN HOUSING	1.000 EA
10XN2520A12	O1/4-20X 3/4 HEX HEAD CAP	4.000 EA
07CB1502A01	CONDUIT BOX LID MACH (DUCTILE IRON)	1.000 EA

Parts List (continued)		
Part Number	Description	Quantity
10XN2520A16	1/4-20 X 1 HEX HEAD CAP SCR, ZINC PLATED	4.000 EA
HW1001A25	LOCKWASHER 1/4, ZINC PLT .493 OD, .255 I	4.000 EA
HW2501F21	KEY, 5/16 SQ X 2.375	1.000 EA
HA7000A02	KEY RETAINER RING, 1 1/8 DIA, 1 3/8 DIA	1.000 EA
85XU0407S04	4X1/4 U DRIVE PIN STAINLESS	4.000 EA
LB1081F	ALUM XP CAUTION LABEL (FS PLANT ONLY-	1.000 EA
LB1115N	LABEL,LIFTING DEVICE (ON ROLLS)	1.000 EA
MJ1000A02	GREASE, POLYREX EM EXXON (USe 4824-15A)	0.050 LB
51XB1214A20	12-14X1.25 HXWSSLD SERTYB	1.000 EA
MG1025G29	WILKOFASST, 789.229, DARK CHARCOAL GRAY	0.036 GA
LB1119N	WARNING LABEL	1.000 EA
LC0145B01	CONNECTION LABEL	1.000 EA
NP0890XPSLEV	SS XP INV UL CSA-EEV CC CL-I GP-D	1.000 EA
07PA1011	PKG GRP, 07 CAST IRON PK1181	1.000 EA
MN416A01	TAG-INSTAL-MAINT no wire (1200/bx) 11/14	1.000 EA

AC Induction Motor Performance Data

Page 1 of 1



AC Induction Motor Performance Data

Record # 40469

Typical performance - not guaranteed values

Winding: 07WGY967	Type: 0728M	Enclosure: XPFC
--------------------------	--------------------	------------------------

Nameplate Data			General Characteristics at 460 V, 60 Hz: High Volt Connection		
Rated Output (HP)	5		Full Load Torque	14.9 LB-FT	
Volts	230/460		Start Configuration	DOL	
Full Load Amps	13.4/6.7		Break Down Torque	48.7 LB-FT	
R.P.M.	1760		Pull-Up Torque	26.6 LB-FT	
Hz	60	Phase	3	Locked-rotor Torque	31.1 LB-FT
NEMA Design Code	B	KVA Code	J	Starting Current	46.2 Amps
Service Factor	1		No-load Current	3.37 Amps	
NEMA Nom. Eff.	90.2	P.F.	77	Line-line Res. @ 25°C.	2.1704 Ohms
Rating - Duty	40C AMB-CONT		Temp. Rise @ Rated Load	38°C	
S.F. Amps			Temp. Rise @ S.F. Load		

Load Characteristics at 460 Volts, 60 Hz, 5 HP

% of Rated Load	25	50	75	100	125	150	S.F.
Power Factor	38	60	71	78	80	82	
Efficiency	83.8	89.4	90.6	90.4	89.7	88.7	
Speed	1791.7	1782.7	1773.6	1763.3	1753.2	1741.8	
Line Amperes	3.69	4.42	5.45	6.7	8.08	9.62	

Baldor Electric Company Fort Smith, Arkansas



2/28/2013

Catalog	IDXM7544T	NP VOLTS	230/460	ENCLOSURE	XPFC	WYE CONN EQ CKT OHMS PER PHASE (BASE RATING, 20C)
FRAME	213TC	NP AMPS	13.4/6.7	Base Volts	460	R1 1.050 X1 3.451
HP	5 HP	DUTY	Cont	Base AMPS	6.7	R2 0.740 X2 2.433
BASE SPEED	1800	MAX SAFE RPM	2700	Slip Hz	1.23	XM1 71.506
PHASE/HZ	3/60	AMB ⁰ /INSUL	40/F	WK ² (lb-ft ²)	0.689	

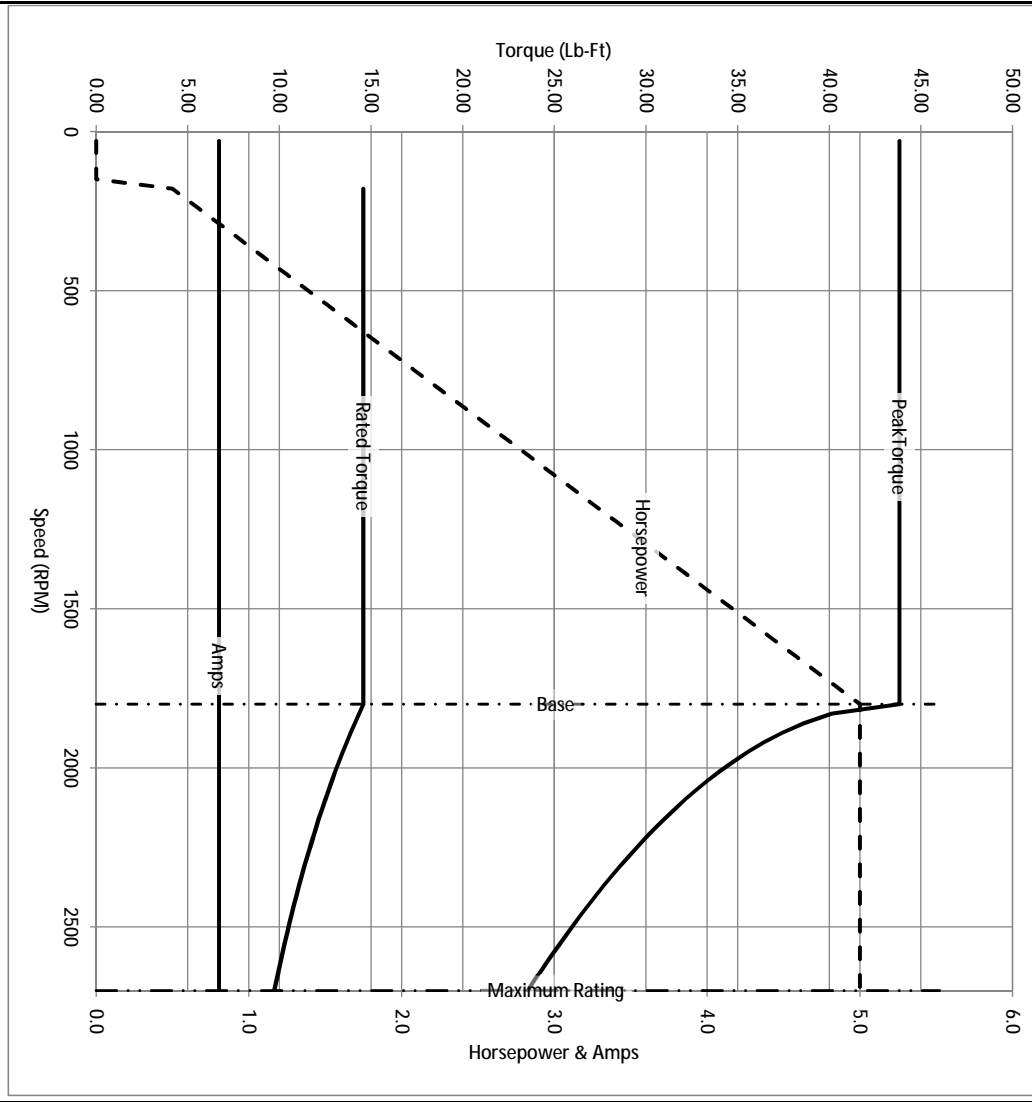

Remarks: Calculated Data

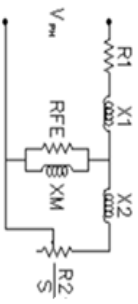

BALDOR
A MEMBER OF THE ABB GROUP

DR BY ENR
CK BY
APP BY ENR
DATE 2/28/2013

A-C MOTOR
PERFORMANCE CURVES

07H867Y967G1
ISSUE DATE 2/28/2013

07H867

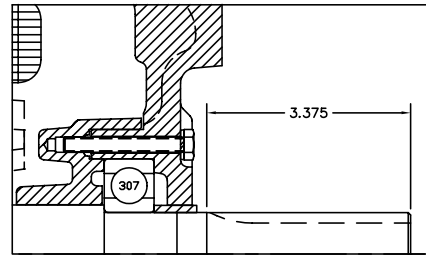
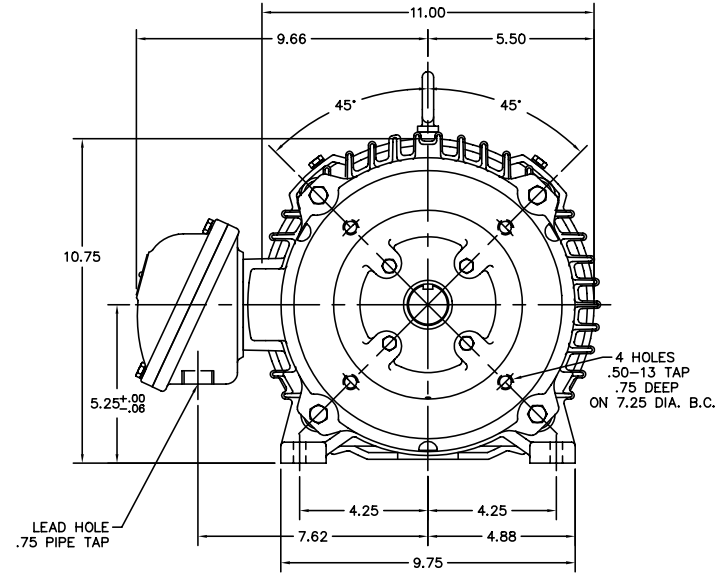
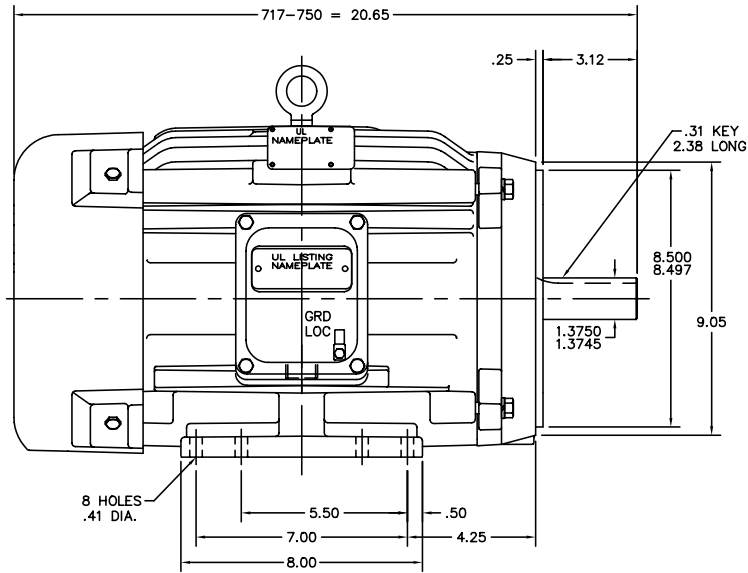

PULLEY END DETAIL

CUST. NAME	CUST. P.O.			REMARKS:		
MODEL	INSUL	AMB	H.P.	MTG	REV: -	NEW
R.P.M.	VOLTS	ENCL	PHASE	FREQ	SCALE: .3	BY: OD
FRAME	TYPE	CERTIFIED BY			FILE: AAA00055447	REVISED: 06/01/98
					TDR: 0153232	

BALDOR ELECTRIC Co.

HOR 213-5TC XPFC 07M CL-I GP-D (INVERTER DUTY)

07H867

CD0005



LOW VOLTAGE
(2Y)



LINE

HIGH VOLTAGE
(1Y)



LINE

NOTES:

1. INTERCHANGE ANY TWO LINE LEADS TO REVERSE ROTATION.
2. OPTIONAL THERMOSTATS ARE PROVIDED WHEN SPECIFIED.
3. ACTUAL NUMBER OF INTERNAL PARALLEL CIRCUITS MAY BE A MULTIPLE OF THOSE SHOWN ABOVE.
4. LEAD COLORS ARE OPTIONAL. LEADS MUST ALWAYS BE NUMBERED AS SHOWN.

REV. DESC: REVISE TO SHOW OPTIONAL COLORS			
REV. LTR: E	BY: JLP	REVISED: 01/19/99 10:15	TDR: 0171435
900003		FILE: AAA00005140	MDL: -
		MTL: -	

BALDOR ELECTRIC Co.

3PH, DV, 9 LEADS

CD0005