

BALDOR® • ***RELIANCE***

Product Information Packet

ZDFRPM21204C

20HP, 1750RPM, 3PH, 60HZ, 2162C, TEFC, FOOT

Part Detail							
Revision:	-	Status:	PRD/A	Change #:		Proprietary:	No
Type:	AC	Prod. Type:		Elec. Spec:	L3308A	CD Diagram:	422927-001
Enclosure:	TEFC	Mfg Plant:		Mech. Spec:		Layout:	617517-023
Frame:	FL2162C	Mounting:	F3	Poles:	04	Created Date:	04-10-2015
Base:		Rotation:	R	Insulation:	H	Eff. Date:	04-13-2015
Leads:						Replaced By:	
Literature:		Elec. Diagram:					

Parts List		
Part Number	Description	Quantity
WS286736	WS P21T0400	1.000 EA
RA282944	RA P21T0400	1.000 EA
000613006NN	RPM AC WITH CERTIFIED LOGOS	1.000 EA
000692000FP	NP, WARNING LIFT INSTRUCTIONS	1.000 EA
036170004EA	ROUND HEAD DRIVE SCREW	4.000 EA
418018079A	LABEL	1.000 EA
418018122A	LABEL	2.000 EA
422927001	C/D LABEL	1.000 EA
036100080KA	M10-1.50X 80MM HXSOCHDCS	3.000 EA
036500010AB	METRIC NUT M10-1.5PLTD400	4.000 EA
036500010AB	METRIC NUT M10-1.5PLTD400	4.000 EA
036610010AB	MHSLW M10 PLATED	4.000 EA
400638001AB	WASHER SPRING - 210	1.000 EA
418057491A	LIFTING LUG	2.000 EA
602018077A	DRAIN	1.000 EA
602018077A	DRAIN	1.000 EA
609830005AN	TBOLT PURGE MTR	4.000 EA
807581003BAA	BRKT,FL210,DE 807581-1WCB	1.000 EA
807581004AAB	BRKT,FL210,DE 807581-2WCB	1.000 EA
032018004AK	HHCS 1/4-20X1/2 PLATED	2.000 EA
034180010DA	KEY 1/4X1/4X1-1/4L	1.000 EA
036000020HB	HHCS M6-1.0X20MM PLATED	4.000 EA
036321020HB	HEXSOCKET FLAT SCREW M	3.000 EA
036620008AB	M6 METRIC EXT LOCKWASHER	1.000 EA

Parts List (continued)		
Part Number	Description	Quantity
065564000B	GASK 250-280	1.000 EA
075452000B	C/BOX, PAINTED 210-250	1.000 EA
075453000A	CBOXC, PAINTED 250-280	1.000 EA
078547001P	FAN 210	1.000 EA
406673002C	.75 CAP PLUG	1.000 EA
415000103A	T/LUG #14AWG-#4AWG W/HOLE FOR .250 BOLT	1.000 EA
415072001B	CLAMP	1.000 EA
417733004T	GASKET CONDUIT BOX	2.000 EA
418018074A	GROUND LABEL G100 METRIC 160 D.C.	1.000 EA
418057373A	SCREW SHEET METAL	7.000 EA
422962051B	STUB SHAFT	1.000 EA
607980163C	TETHER KIT	1.000 EA
607980163D	TETHER KIT	1.000 EA
607980192A	RF,BEI,HS35,TWISTLOCK	1.000 EA
708533003A	PLATE, BTM FAN/BLOWER	2.000 EA
708533050A	COVER, FAN	1.000 EA
708533051A	GRILL, FAN COVER	1.000 EA
000640000P	TAG WINDING THERMOST	1.000 EA
004824007K	SPECIAL PAINT	0.100 EA
034180022FA	KEY 3/8X3/8X2-3/4 L	1.000 EA

REL. S.O. - VOLTS 460 ENCLOSURE TEFC WYE CONN EQ CKT OHMS PER PHASE
 FRAME FL2162 AMPS 27 MAX SAFE RPM 5000 (AT BASE RATING, 25 °C)
 HP 20 DUTY CONT IM (AMPS) 15 R1 .179 X1 .845
 BASE SPEED 1775 S.F. 1.0 P.F.@NL/FL .066/.777 R2 .122 X2 1.09
 PHASE/HERTZ 3/60 AMB °C/INSUL 40/H MK² (LB-FT²) 1.92 XM 18.1

RATED FULL LOAD DATA



	RPM	HP	TORQUE LB-FT	FUND VOLTS	FREQ-HZ	AMPS
BASE SPEED	1774	20.0	59	460	60	26.9
MAX SPEED	3543	20.0	30	460	120	24.4
MIN SPEED	0	0	59	13.8	.874	26.9

LOAD PERFORMANCE AT BASE SPEED

	RPM	HP	TORQUE LB-FT	FUND VOLTS	FREQ-HZ	AMPS
NO LOAD	1800	0	0	460	60	14.4
1/4	1794	5.01	15	460	60	15.7
1/2	1787	10.0	29	460	60	18.6
3/4	1781	15.0	44	460	60	22.4
FULL LOAD	1774	20.0	59	460	60	26.9
O/L	1742	39.3	119	460	60	48.5

BLOWER DATA	VOLTS	PH/HZ	FL AMPS	LR AMPS	FRAME	CFM

REMARKS: TYPICAL DATA
CORRELATED DATA

	DR. BY B. GRANT	
	CK. BY T. CUER	
APP. BY 6-6-06	DATE 6-6-06	ISSUE DATE 6-6-06

1

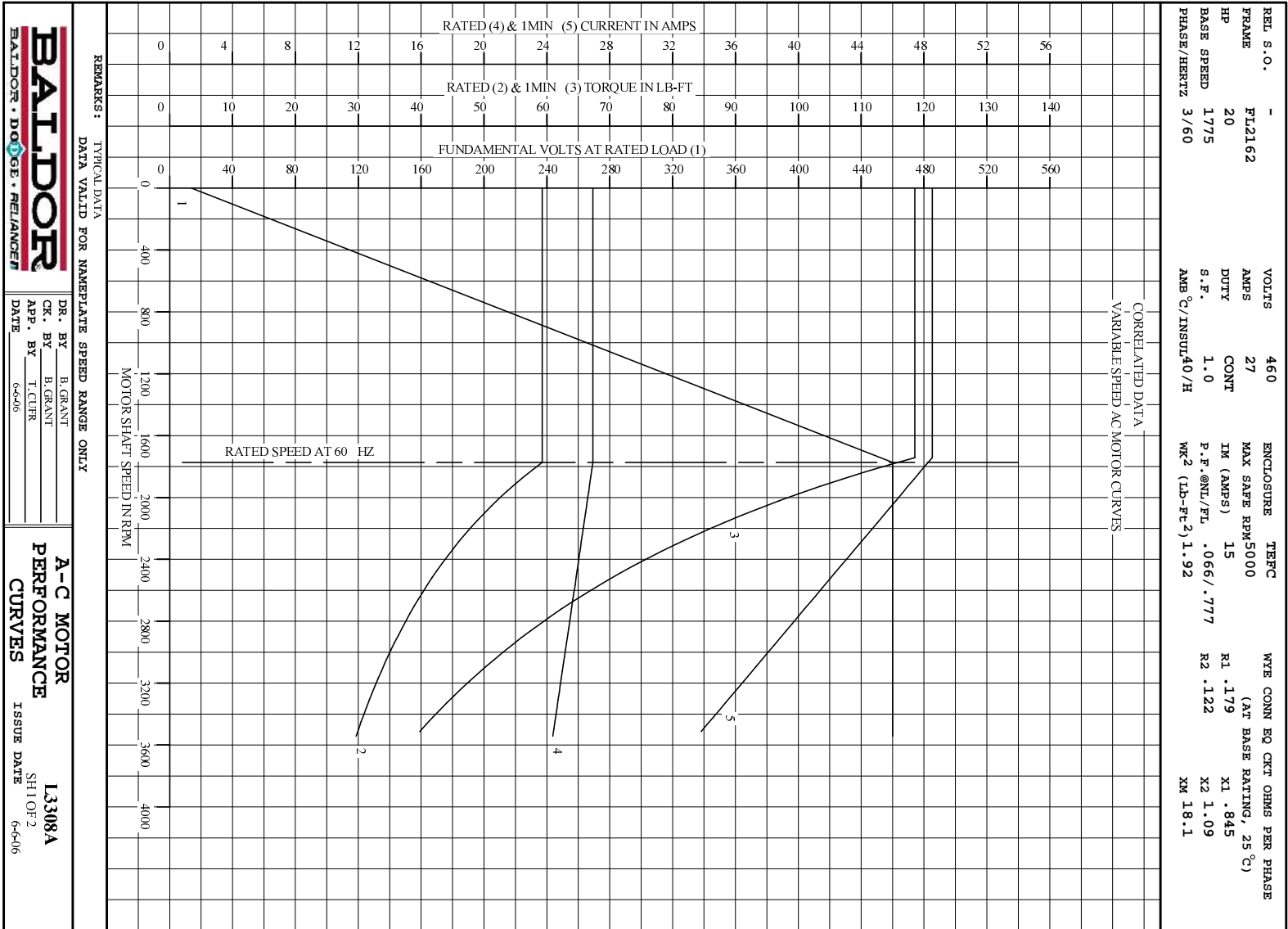

REMARKS: TYPICAL DATA
DATA VALID FOR NAMEPLATE SPEED RANGE ONLY

BALDOR
BALDOR • DOUGLASS • RELIANCE

DR. BY B. GRANT
CK. BY B. GRANT
APP. BY T. CURR
DATE 6-6-06

A-C MOTOR
PERFORMANCE
CURVES

L3308A
SH 1 OF 2
ISSUE DATE 6-6-06

1

REL S.O.	-	VOLTS	460	ENCLOSURE	TEFC	WYE CONN EQ CKT OHMS PER PHASE
FRAME	FL2162	AMPS	27	MAX SAFE RPM	5000	(AT BASE RATING, 25°C)
HP	20	DUTY	CONT	IM (AMPS)	15	R1 .179 X1 .845
BASE SPEED	1775	S.F.	1.0	P.F.@NL/FL	.066/.777	R2 .122 X2 1.09
PHASE/HERTZ	3/60	AMB C/INSUL	40/H	WK ² (LB-FC ²)	1.92	XN 18.1

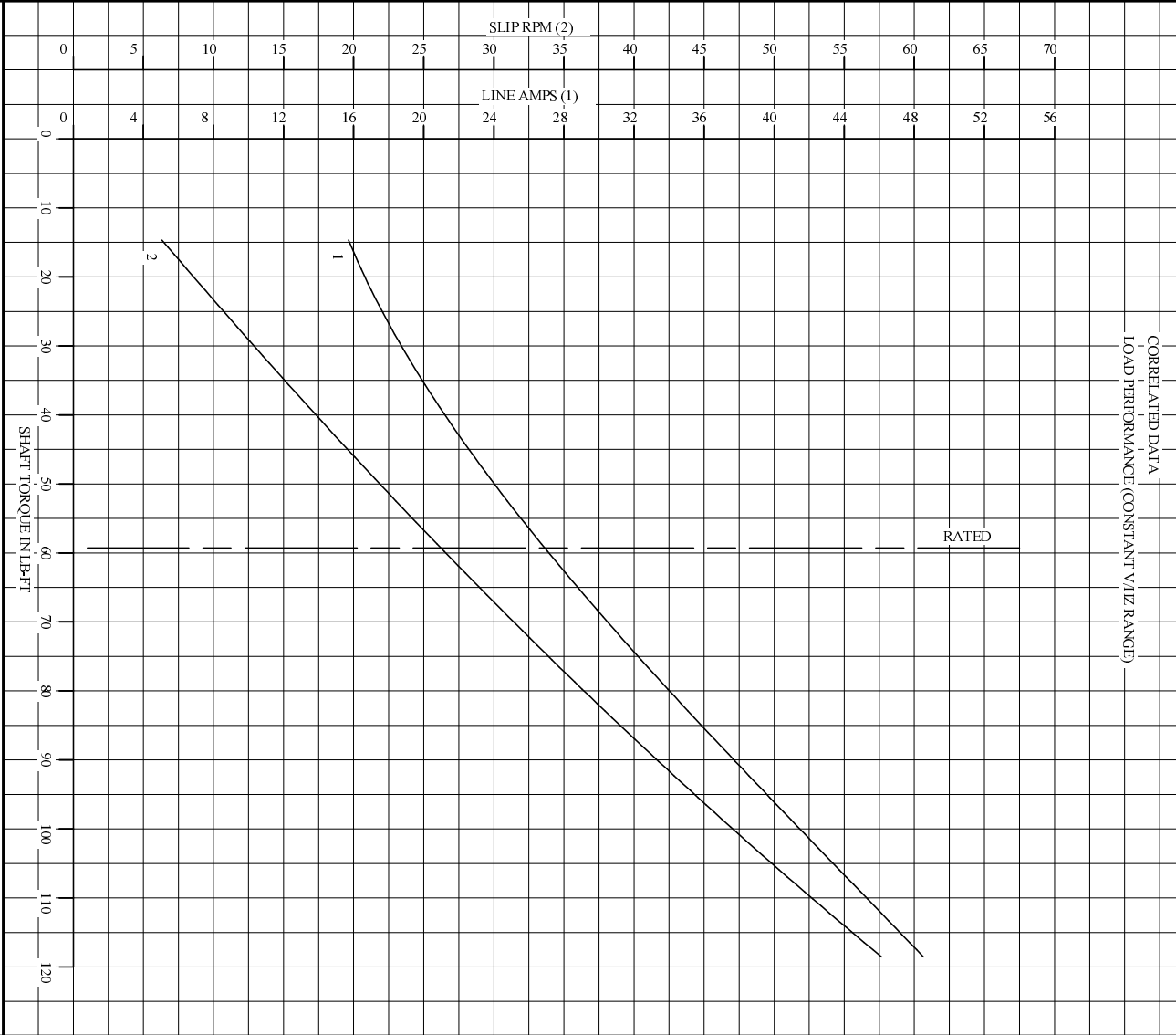

REMARKS: TYPICAL DATA
DATA VALID FOR NAMEPLATE SPEED RANGE ONLY

BALDOR BALDOR • DOUG • RELIANCE	DR. BY	B. GRANT	A-C MOTOR PERFORMANCE CURVES	L3308A SH20F2 ISSUE DATE 6-6-06
	CK. BY	T. CURR		
APP. BY		6-6-06		
DATE				

617517-023

RPM-AC FINNED FRAME VARIABLE SPEED ALTERNATING
CURRENT MOTOR
FL2162CZ

ENCLOSURE: TOTALLY ENCLOSED
MOUNTING: FOOT / NEMA 250TC C-FACE
DRIVE METHOD: COUPLED OR BELTED

COOLING: BLOWER COOLED or
FAN COOLED
ACCESSORIES: PROVISIONS FOR
TACHOMETER MOUNTING
ONLY WHEN SPECIFIED

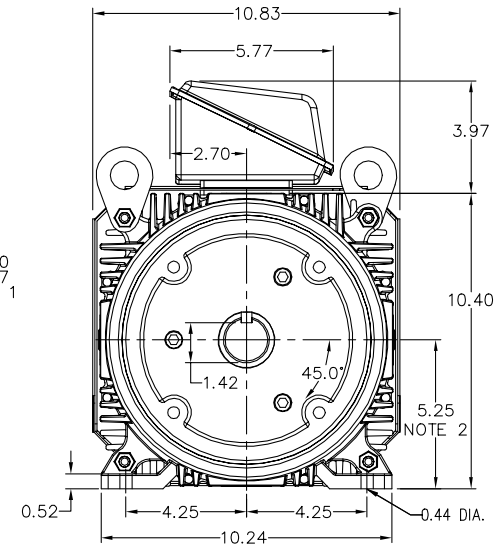
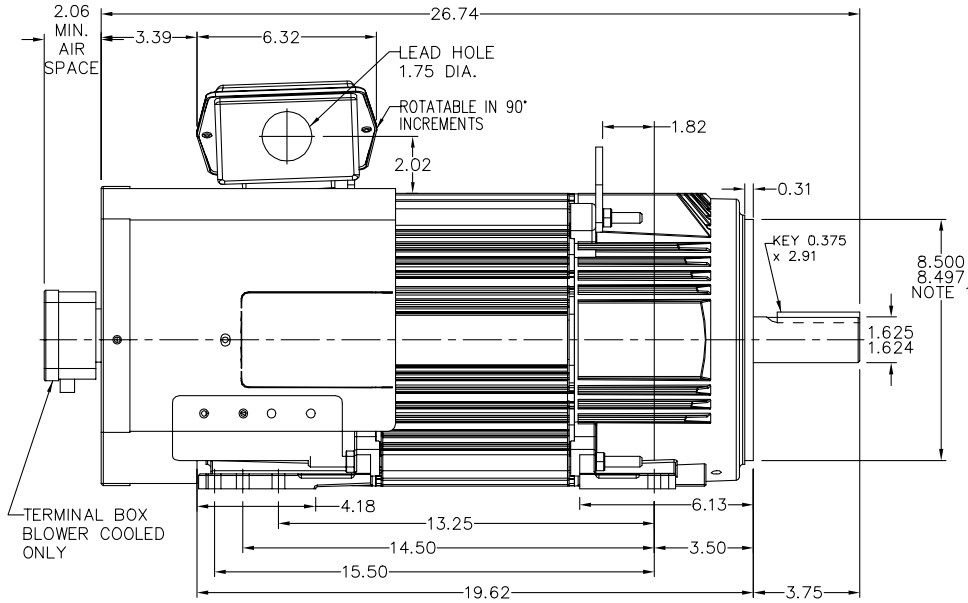

NOTE 1: C-FACE & TACHOMETER MOUNTING
1/2-13 TAP, 1.00 DEEP, ON A 7.25 DIA. BOLT CIRCLE
FACE RUNOUT AND ECCENTRICITY 0.004 MAX. T.I.R.

NOTE 2: SHAFT HEIGHT WILL NOT BE EXCEEDED
SHIMS UP TO 0.03 INCHES IN THICKNESS ARE USUALLY
REQUIRED FOR COUPLED OR GEARED MACHINES

TERMINAL BOX MAY BE LOCATED F1 OR F2 IF SPECIFIED
61 AMP STEEL TERMINAL BOX SHOWN
REFER TO 616779-50 FOR SPECIFIED TERMINAL BOX DIMENSIONS
REFER TO 616779-55 FOR SPECIFIED TACHOMETER DIMENSIONS

MOTOR WEIGHT: 290 LBS. (MAY VARY 15%)
DIMENSIONS ARE IN INCHES SCALE: 1.00

617517-023

CUSTOMER IS RESPONSIBLE FOR DETERMINING THAT BALDOR'S PRODUCT WILL PERFORM SUITABLY IN THE INTENDED APPLICATION.

REV. DESC: ADDED C-FACE DEPTH DIMENSION	VERSION: 01	TDR: 000000493632
REV. LTR: A	REVISED: 13:20:53 03/13/2009	BY: CONDLM
FILE: \RGG\00003\195		
MTL: -		

BALDOR • DODGE • RELIANCE
DIM SHT RPMAC TEFC/FC FL2162CZ FT MT PROV FOR TACH
SH 1 of 1

618779-050

INDUSTRIAL ALTERNATING CURRENT MOTORS

RPM AC

STEEL, CAST IRON, MILL AND TERMINAL BOARD CONDUIT BOX DIMENSIONS
 NEMA FRAMES FL210 thru RL280 and IEC FRAMES RDL132 thru RDL180
 NEMA FRAMES FL180 thru FL280 and IEC FRAMES FDL112 thru FDL180

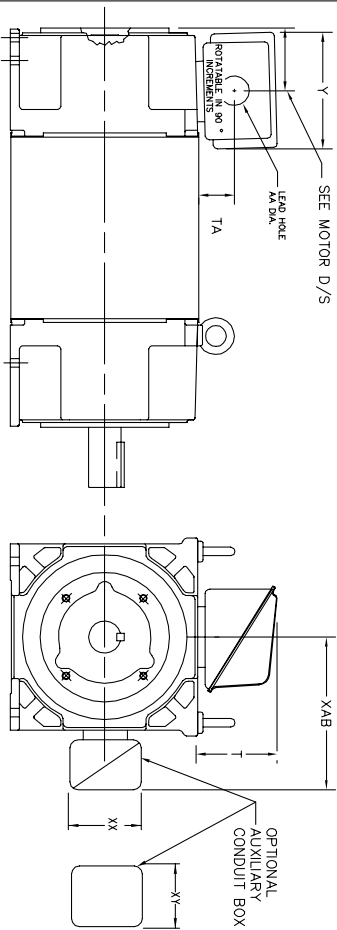

TERMINAL BOX	Y	TA	T	AA	MAX AMP	REMARKS
706310-63B	14.39	7.43	12.15	--	400	TERMINAL STRIP
706310-226R	9.00	3.06	5.40	Pg36 & Pq16	160	TERMINAL STRIP
706310-225R	7.25	2.30	4.40	Pg29 & Pq16	100	TERMINAL STRIP
706310-56B	9.00	3.06	5.40	Pg36 & Pq16	160	TERMINAL STRIP
706310-56A	7.75	2.30	4.40	Pg29 & Pq16	100	TERMINAL STRIP
706320-14D	15.00	7.56	12.81	5	510	CAST IRON
706320-13A	10.50	4.88	9.00	4.0 TAP	210	CAST IRON
706320-12B	9.25	4.81	8.56	3	140	CAST IRON
75460-62B	7.25	2.50	5.25	1.5 TAP	110	CAST IRON
706320-4C	5.75	2.38	4.38	1.0 TAP	60	CAST IRON FL180 ONLY
706310-3E	16.00	4.40	7.81	3	590	MILL
706310-3X	8.00	2.38	5.00	--	160	MILL
702658-1G	14.62	7.56	12.70	5	500	STEEL
706320-16A	9.00	4.12	8.44	4.59	305	STEEL
706320-9A	7.25	3.50	7.06	2.50	160	STEEL
75454-1AJ	7.69	2.38	5.25	1.94	121	STEEL
75452-B	6.34	2.00	4.12	1.75	61	STEEL
75452-G	6.34	2.00	4.12	--	61	SPECIAL
706320-5A	6.12	2.38	4.38	1.75/2.00	75	STEEL FL180 ONLY
706320-3A	5.00	1.62	3.00	1.12	40	STEEL FL180 ONLY
706320-7A	7.62	2.00	7.00	2.5/3.0	208	STEEL FL180 ONLY

FRAME SIZE	XAB	OPTIMAL AUXILIARY CONDUIT BOX DIMENSIONS (MAXIMUM)				PART NUMBER			
		XX	XY	XZ	XY				
FL210/FL132/RL210/RL132	7.38	4.25	4.25	6.0200-26-A	FL210/FL132/RL210/RL132	10.88	8.00	8.00	706310-3-B
FL230/FL180/RL230/RL180	8.44	4.23	4.23	6.0200-26-A	FL230/FL180/RL230/RL180	11.88	8.00	8.00	706310-3-B
FL280/FL180/RL280/RL180	9.12	4.23	4.23	6.0200-26-A	FL280/FL180/RL280/RL180	12.62	8.00	8.00	706310-3-B

- (1) 'AA' CONDUIT.
- (2) 'AA' PIPE TAP.
- (3) CUSTOMER TO PROVIDE HOLE FOR CONDUIT.
- (4) Z DIA -3A or 1 TAP DIA -4C

TERMINAL BOX CAN BE ROTATED FOR LEAD OUTLET AT TOP, SIDES OR BOTTOM.
 TERMINAL BOX LOCATED ON OPPOSITE SIDE WHEN F-2, W-1, W-4, W-5, W-7,
 OR C-1 MOUNTING IS SPECIFIED. BOX LOCATED ON TOP WHEN SPECIFIED.

050-60761919

CUSTOMER IS RESPONSIBLE FOR DETERMINING THAT BALDOR'S PRODUCT WILL PERFORM SUITABLY IN THE INTENDED APPLICATION.

REV. DESC: BOX # 706320-9A, CHANGE AA DIM FROM 2 TO 2.50	TDR: 000000785386
REV. LTR: C	VERSION: 03
FILE: \RGG\00003\692	REVISED: 08:40:55 02/11/2013
MTL: -	BY: RGGWT

BALDOR

DIM SHT NEMA RL210-RL280 FL180-FL280 IEC RDL132-RDL180

SH 1 of 1

616779-055

RPM AC TACHOMETER DIMENSIONS
NEMA FRAMES FL180 thru FL440 and IEC FRAMES FDL112 thru FDL280
 DIMENSIONS ARE IN INCHES(mm)

DPFV, DPSV, TEPV, TESV, TENV & TEAO-PB
 IC06, IC17, IC37, IC410, & IC416-PB

TACH MODEL	XL Inchest(mm)	LBS.
BEI DE DYNAPAR HS35	2.88 (74)	5
DYNAPAR H20	7.50 (191)MAX	10
NORTHSTAR HS35M	3.31 (84)	10
NORTHSTAR ST67	2.88 (74)	5
DYNAPAR H56	10.56 (268)	40
AVTRON M3 DR M4	3.62 (92)	10
TAMAGAWA TS5013(17)	6.00 (152)	10
NORTHSTAR ST56	2.88 (74)	5
NORTHSTAR ST85	2.00 (51)	5
BEI H38D	10.17 (259)	15
TAMAGAWA TS2151	2.64 (67)	15
BEI H23	7.50 (191)	15
DYNAPAR H20	2.00 (50.8)	5
DYNAPAR H25	12.88 (327)	10
STEGMANN SRS25	7.25 (184.4)	10
NORTHSTAR HS135	3.00 (76.2)	10
HEIDENHAIN ERM425	2.5 (63.5)	5
AVTRON HS35M	4.19 (106.4)	5
HEIDENHAIN ERN480	5.00 (127.0)	5
DYNAPAR H125	7.00 (177.8)	10
DYNAPAR H22	3.62 (92.1)	5
AVTRON H255	2.54 (64.5)	9
AVTRON AV950	2.54 (64.5)	9
AVTRON AV56	4.50 (115)	15
HS138	3.30 (84)	5
HS125	3.30 (84)	2
NORTHSTAR RT8	3.25 (82)	15
DYNAPAR H4625	5.88 (150)	10
AVTRON AV485	5.50 (141)	18

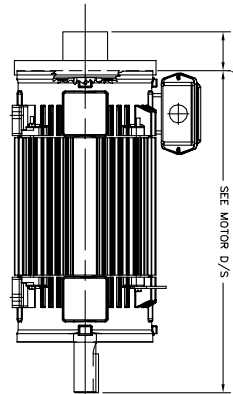

* THIS DIMENSION INCLUDES COVER FOR X/7 MOTOR.

TEAO-BC, IC416-BC

TACH MODEL	XL Inchest(mm)	LBS.
BEI DE DYNAPAR HS35	4.50 (115)	15
DYNAPAR H20	4.50 (115)	10
AVTRON M3 DR M4	4.50 (115)	10
NORTHSTAR HS35M	4.50 (115)	15
NORTHSTAR ST56	4.50 (115)	10
NORTHSTAR ST67	4.50 (115)	10
NORTHSTAR ST85	4.50 (115)	5
TAMAGAWA TS5008 TS5013	4.50 (115)	10
DYNAPAR H20	4.50 (115)	15
STEGMANN SRS25	4.50 (115)	10
STEGMANN SRS25/SH50	4.50 (115)	3
STEGMANN SRS360	4.50 (115)	15
H20 & H2E	4.50 (115)	15
AVTRON HS35M	4.50 (115)	10
AVTRON AV85	4.50 (115)	10
AVTRON M56	4.50 (115)	5
AVTRON AV67	4.50 (115)	10
HS138	4.50 (115)	5
TS2014	4.50 (115)	10
AVTRON HS45	4.50 (115)	15
DYNAPAR HS138M	4.50 (115)	15

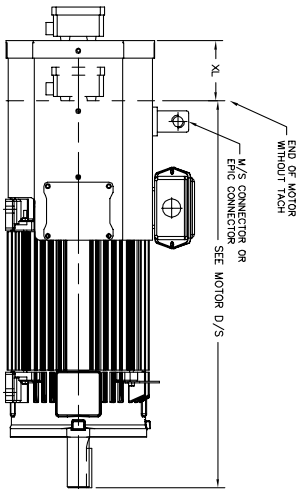

CUSTOMER IS RESPONSIBLE FOR DETERMINING THAT BALDOR'S PRODUCT WILL PERFORM SUITABLY IN THE INTENDED APPLICATION.

REV. DESC: ADD TAMAGAWA TS5008 (B1248085)	TDR: 000000895710
REV. LTR: U	VERSION: 19
FILE: \RGG\00003\694	REVISED: 08:00:14 03/06/2015
MTL: -	BY: RGGWT

BALDOR

DIM SHT TACH DIM NEMA FL180 - FL440 IEC FDL112 - FDL280

SH 1 of 1

TEFC, IC411

TACH MODEL	XL Inchest(mm)	LBS.
BEI HS35	2.88 (74)	7
NORTHSTAR HS35M	3.31 (84)	10
DYNAPAR H20	3.75 (95)	15
DYNAPAR HS35, HS138	2.88 (74)	7
H20(X1)	9.75 (248)	35
ERM425	7.50 (201)	35
AVTRON HS35M	4.19 (106)	2
STEGMANN SRS50	3.75 (95)	1
DYNAPAR H20	2.00 (51)	1
NORTHSTAR HS135	2.81 (71)	2
NORTHSTAR HS138	3.30 (84)	5

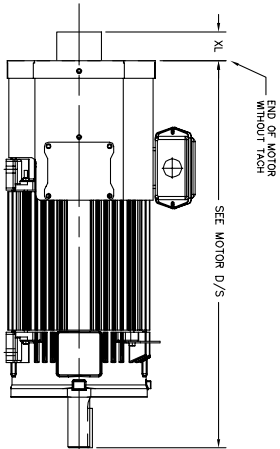

055-6179-6

422927-001

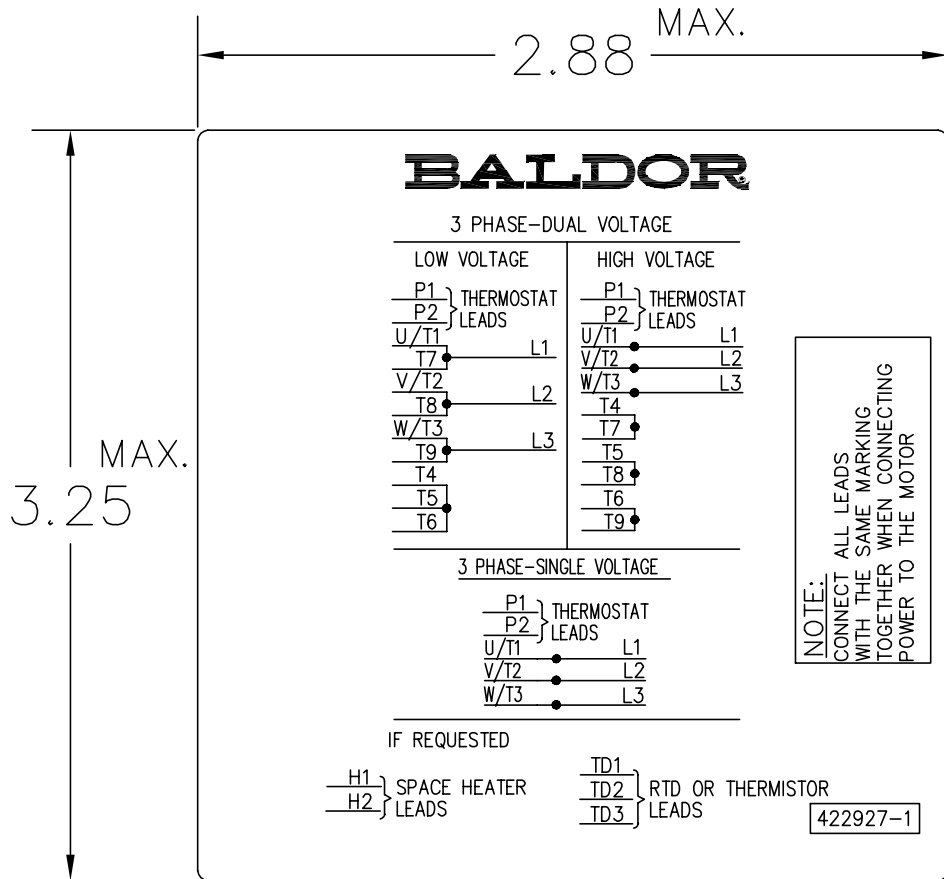

NOTE:
DATA TO BE SIZED SO THAT IT FITS INTO MATERIAL DECAL DIMENSIONS. MAKE LETTERS & NUMBERS AS LARGE AS POSSIBLE.

MATERIAL: CERAMATIC DGF-P4
PERMA GRIP ADHESIVE

ALL LETTERS, NUMBERS AND LINES TO BE BLACK ON WHITE BACKGROUND.

422927-001

REV. DESC: CHANGE BACKGROUND COLOR FROM GOLD TO WHITE		
REV. LTR: B	VERSION: 02	TDR: 000000788708
FILE: \RGG\00000\203	REVISED: 08:09:29 03/04/2013	
MTL: -	BY: RGGWT	

BALDOR

EXTERNAL CONNECTION LABEL

SH 1 of 1

Marketing maintained PDF of MN406:

<http://www.baldor.com/support/Literature/Load.ashx/MN406?ManNumber=MN406>