

SE and SL pumps, 12-42 Hp

12-42 hp

60 Hz, ANSI



1. Introduction	3	11. Grundfos Product Center	169
Applications	3	Grundfos GO	170
Hydraulic variants	3		
Product features	4		
2. Performance range	5		
Performance range, SE, SL and S pumps	5		
Performance range, SE and SL pumps, 12-42 hp	5		
3. Pump options	6		
4. Identification	7		
Nameplate	7		
FM warning plate with restrictions	7		
Type key	8		
5. Product selection	9		
Hydraulics selection	9		
Basic pump configuration	13		
Variants of customized pumps	13		
Flange forces	15		
6. Construction	16		
Sectional drawings, motors	16		
Sectional drawings, pumps	22		
Exploded views	30		
Components and material specification	38		
7. Product description	40		
Features	40		
Operating conditions	43		
Level controllers	45		
Wiring diagrams	47		
Sensor wiring	49		
8. Performance curves and technical data	55		
How to read the performance curves	55		
Curve conditions	56		
Performance tests	56		
Certificates	56		
Witness test	56		
SuperVortex impeller	57		
Closed S-tube [®] impeller	65		
Open S-tube [®] impeller	112		
9. Accessories	136		
Installation systems	136		
10. Dimensions	142		
Recommendation for pump foundations	142		
Pump installation dimensions	143		

1. Introduction

This data booklet describes Grundfos SE and SL heavy-duty wastewater pumps, 12-42 hp.



TM077249

SE and SL pumps

The 12-42 hp SE and SL pumps are a range of SuperVortex and S-tube® impeller pumps specifically designed for transferring sewage and wastewater in a wide range of municipal, private and industrial applications.

SE pumps are equipped with an internal closed-loop cooling system, which enables dry installation.

SL pumps do not have a cooling system as they are used for submersible installations only.

The pumps are made of resistant materials, such as cast iron and stainless steel. These materials ensure proper operation.

The pumps are fitted with IEC, IE3, and NEMA premium efficiency motor components.

The free passage in the pumps is 1.5"-5" (35-125 mm).

The pumps are available for:

- submersible installation on an auto-coupling with completely submerged motor
- submersible installation on an auto-coupling with liquid covering the pump housing
- vertical, dry installation
- horizontal, dry installation.

Applications

- drainage and surface water
- domestic wastewater
- municipal wastewater
- industrial wastewater
- process and cooling water.

SE and SL pumps are ideal for pumping the above liquids from places such as:

- municipal network pumping stations
- inlet pumping stations in wastewater treatment plants
- primary and secondary clarification tanks in wastewater treatment plants
- stormwater pumping stations
- public buildings
- residential buildings
- factories and industry.

Hydraulic variants

To meet customer demands, Grundfos SE and SL pumps are offered with three different hydraulic platforms depending on hydraulic variant and pump size.

SE and SL wastewater pumps are available with:

- Open S-tube® (semi-open impeller) hydraulics (SE and SL).
- Closed S-tube® (channel impeller) hydraulics (SE1/SE2 and SL1/SL2).
- SuperVortex (free flow impeller) hydraulics (SEV and SLV).

SE/SL pumps with open S-tube® hydraulics

Grundfos SE/SL pumps with open S-tube® hydraulics are the ideal choice when there is a need for a wastewater pump with high wire-to-water efficiency and must operate over a wider Allowable Operating Range (AOR). Open S-tube® impellers can be trimmed to meet a specific duty-point

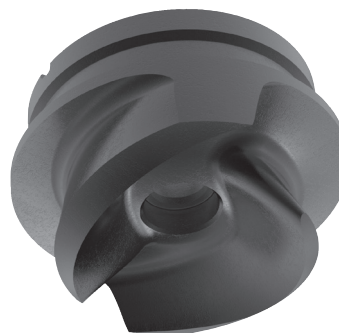

TM078832



TM078833

Pumps are available in the following material variants:

- Cast iron (standard solution) - Applicable for the vast majority of wastewater applications.
- Stainless steel – Q material variant (standard solution) - Applicable for the vast majority of wastewater applications with larger volume of abrasives.
- White cast iron - W material variant (customized solution) - Ideal when the pumped liquid contains a high amount of abrasive solids.

SE/SL pumps are available in super-high – and high head variants.

SE1/SE2 and SL1/SL2 pumps with closed S-tube® hydraulics



TM078831

Grundfos SE/SL pumps with closed S-tube® (1- or 2-channel impellers, depending on pump size) hydraulics are the ideal choice when there is a need for a wastewater pump with large free passage and must operate with a wide and flat efficiency curve.

Pumps are available in the following material variants:

- Cast iron (standard solution)
Applicable for the vast majority of wastewater applications.
- Stainless steel – Q material variant (standard solution)
Applicable for the vast majority of wastewater applications with larger volume of abrasives.
- Duplex stainless steel (customized solution)
Ideal when the pumped liquid contains a high amount of abrasive solids.

SEV/SLV pumps with SuperVortex hydraulics



TM078834

Grundfos SEV/SLV pumps with SuperVortex hydraulics are the ideal choice when you require a wastewater pump that has a free-flow impeller for higher efficiency, a large and uncompromized free spherical passage and is optimized for applications balancing a high solids content and relatively low operating hours. SuperVortex impellers can be trimmed to meet a specific duty-point.

Pumps are available in the following material variants:

- Cast iron (standard solution)
Applicable in the vast majority of wastewater applications.
- Stainless steel – Q material variant (standard solution)
Applicable for the vast majority of wastewater applications for a larger volume of abrasives.
- Duplex stainless steel (customized solution)
Ideal when the pumped liquid contains a higher content of abrasive solids.

SEV/SLV pumps are available in super-high head variant.

Product features

Grundfos SE and SL pumps offer the following benefits:

- optimized high-efficiency and self-cleaning hydraulics to minimize the risk of clogging
- moisture-tight sealed cable entry at the motor top compartment made of corrosion-resistant stainless steel
- double mechanical cartridge shaft seals, fully assembled and tested at the factory, for reliable sealing between the liquid in the pump housing and the motor
- integrated sensors for continuous monitoring and protection of the pump during operation
- SmartTrim system allowing easy adjustment of the impeller clearance without disassembly of the pump, maintaining maximum performance throughout the life of the pump
- high-efficiency electrical motors built on IE3 motor components and fulfilling the latest standards
- explosion-proof pumps for applications involving a high risk of ignition.

2. Performance range

Performance range, SE, SL and S pumps

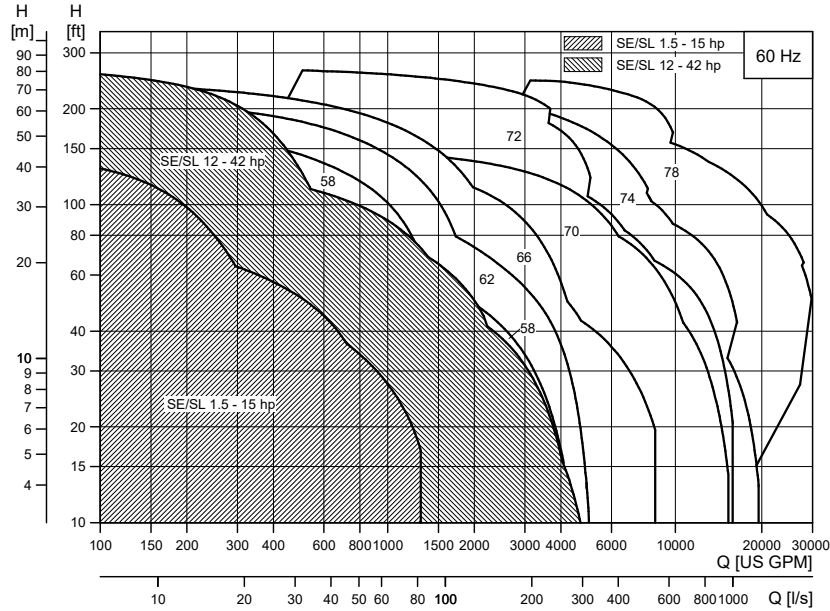

TM054845

Performance range, SE and SL pumps, 12-42 hp

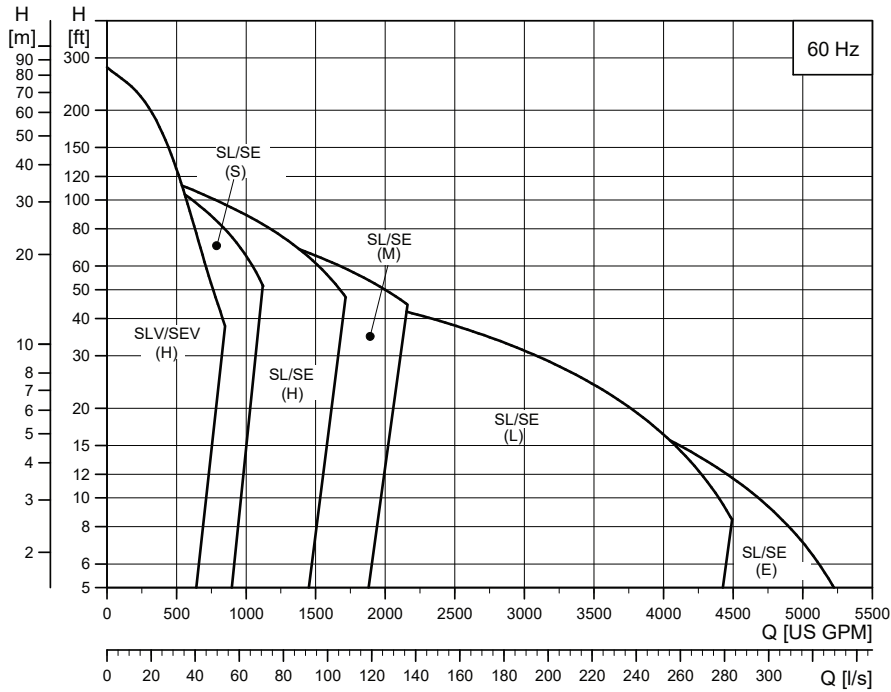

TM075961

3. Pump options

The SE and SL pumps can be customized to meet individual requirements. The following pump features and options are available:

- Sensor variant
 - Standard: pump fitted with standard sensors
 - A: pump fitted with sensor version 1 ¹⁾
 - B: pump fitted with sensor version 2 ¹⁾
- Pressure range
 - 52S: super-high head
 - 52H: high head
 - 52M: medium head
 - 52L: low head
 - 52E: extra-low head
- Material for closed S-tube[®] hydraulics
 - Standard: cast iron pump housing, cast iron impeller, cast iron motor housing
 - Stainless steel (Q variant): cast iron pump housing, stainless steel impeller, cast iron motor housing
- Material for open S-tube[®] hydraulics
 - Standard: cast iron pump housing, cast iron impeller, cast iron suction cover, cast iron motor housing
 - Stainless steel (Q variant): cast iron pump housing, stainless steel impeller, cast iron suction cover, cast iron motor housing
 - White iron (WI - customised solution): cast iron pump housing, white iron impeller, white iron suction cover, cast iron motor housing
- Material for SuperVortex hydraulics
 - Standard: cast iron pump housing, cast iron impeller, cast iron motor housing
 - Stainless steel (Q variant): cast iron pump housing, stainless steel impeller, cast iron motor housing
- Pump version
 - N: pump without FM approval
 - Ex: pump with FM approval
- Supply voltage
 - 61F: 3 x 220-230 V (D), 380-400 V (Y)
 - 61G: 3 x 380-480 V (D), 660-690 V (Y)
 - 61M: 3 x 575-600 V (D)
 - 611: 3 x 460 V (D)
 - 615: 3 x 380 V (D), 660 V (Y)
 - 60S: 208 V (D)
 - 61R: 230 V (D), 460 V (Y)
 - 60R: 230 V (D)
- Thermal protection
 - Standard: thermal switches
 - T: thermistor (PTC), including 49 ft power cable.

¹⁾ Use screened cables to ensure optimal data communication with the pump.

For variants see Variants of customised pumps. For requirements or designs not included in the list, contact Grundfos.

4. Identification

Nameplate

The pumps can be identified from the nameplate on the motor top cover.

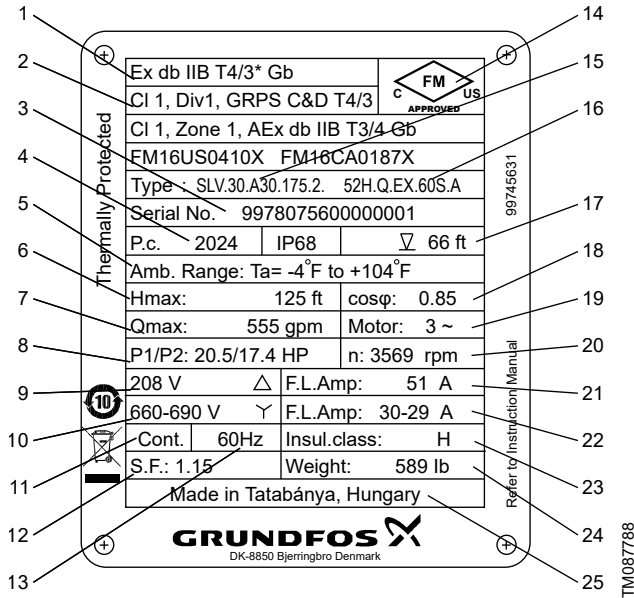

Nameplate example for FM approved pumps made in Hungary

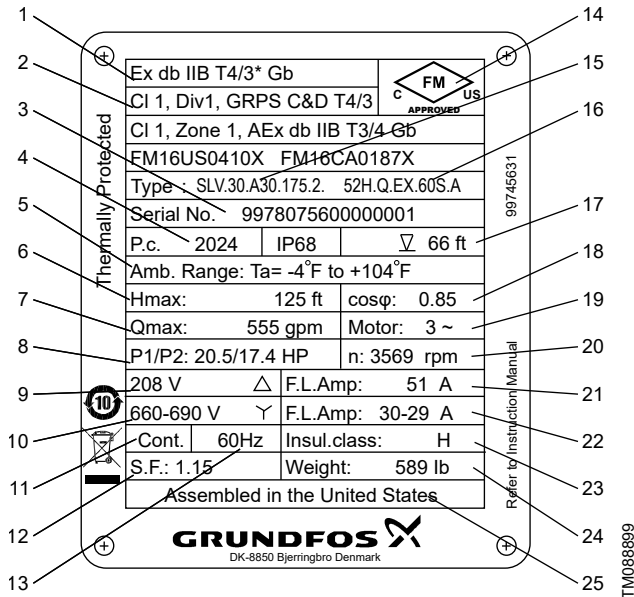

Nameplate example for FM approved pumps assembled in the United States

FM warning plate with restrictions



FM warning plate

Pos.	Description
1	Explosion-protection classification
2	Explosion-protection classification
3	Serial number
4	Production code, year and week
5	Maximum ambient temperature
6	Maximum head
7	Maximum flow rate
8	Rated power input/output (P1/P2)
9	Rated voltage, delta connection
10	Rated voltage, star connection
11	Continuously operated motor
12	Service factor
13	Frequency
14	Approval marking
15	Type designation (part 1)
16	Type designation (part 2)
17	Maximum installation depth
18	Power factor
19	Number of phases
20	Rated speed
21	Rated current, delta connection
22	Rated current, star connection
23	Insulation class
24	Weight without cable
25	Country of production

Type key

Example: **SE1.45.A80.270.4.52.M.EX.6.1G.A**

Code	Explanation	Designation
SE	Sewage pump with cooling jacket	Pump type
SL	Sewage pump without cooling jacket	
[]	Open S-tube® impeller (semi-open)	Impeller type
1	Closed single-channel S-tube® impeller	
2	Closed two-channel S-tube® impeller	
V	SuperVortex (free-flow) impeller	
[]		Pump free passage [in]
30	3" (80 mm)	
35	3.5" (85 mm)	
40	4" (105 mm)	
45	4.5" (110 mm)	
50	5" (125 mm)	
A80	8": Pump outlet nominal diameter/10	Pump outlet [ANSI (in)]
270	27.0 hp: P2/10	Shaft power P2 [hp]
[]	Standard pump or standard Ex pump without additional sensors	Sensor version
A	Sensor version 1 or sensor version 1, Ex/FM pump	
B	Sensor version 2 or sensor version 2, Ex/FM pump	
2	2-pole motor	Number of poles
4	4-pole motor	
6	6-pole motor	
52.S	Super-high pressure	Frame size of the pump (52.) and head class
52.H	High pressure	
52.M	Medium pressure	
52.L	Low pressure	
52.E	Extra-low pressure	
[]	Cast iron pump housing, cast iron impeller, cast iron suction cover, cast iron motor housing	Material code for pump, impeller, suction cover and motor housing
Q	Cast iron pump housing, stainless steel impeller, cast iron suction cover, cast iron motor housing	
W	Cast iron pump housing, heavy-duty wear-resistant impeller, heavy-duty wear-resistant suction cover, cast iron motor housing	
N	Pump without Ex, FM or UL approval	Pump version
Ex	Pump with Ex or FM approval	
UL	Pump with UL approval	
6	60 Hz	Frequency
1F	3 x 220-230D/380-400Y	Voltage
1G ²⁾	3 x 380-480D/660-690Y (Standard)	
11 ³⁾	3 x 460D (Standard)	
15 ³⁾	3 x 380D/660Y	
1M	3 x 575-600D	
0S	3 x 208D	
1R	3 x 230D/460Y	
0R	3 x 230D	

Code	Explanation	Designation
[]	1st generation	Generation code
A	2nd generation	
Z	Custom-built product	Customization
[]	Thermal switches	Thermal protection
T	PTC thermistor	

2) Only for 2- and 4-pole motors.

3) Only for 6-pole motors.

5. Product selection

Consider the following:

- Liquid type
- Inflow requirement
- Total head requirement
 - After a few months, the typical surface roughness in pipes is 0.02 to 0.04 inch.
- Size of the pipe on the discharge side of the pump
 - For a self-cleaning effect in the pipes, the flow velocity must exceed 3.3 ft/s.
- Standby pump requirements
 - To avoid sedimentation, the pumps must be started at least twice a day.
- Inlet conditions to avoid cavitation
- Installation type
- Customization
- Accessories

If sizing and selection is done via Grundfos Product Center in www.grundfos.com, the selection recommendations may list one or more standard pumps, for example:

Product name: SE1.45.A80.270.4

- To identify the pump, use the [Features of a standard pump](#):

Hydraulics selection

Use the following tables to identify the most suitable pump hydraulics type.

Liquid description	Recommended material grade	Open S-tube® hydraulics without guide vane (standard)	Open S-tube® hydraulics with guide vane (optional)	Closed S-tube® hydraulics	Supervortex hydraulics	Recommendations
Surface water						
Drainage water	Grey cast iron	x		x	x	
	Stainless steel (Q variant)	x		x	x	
	White cast iron (W variant)		x			
River water	Grey cast iron	x		x	x	Observe operating conditions when selecting optimal hydraulic variant.
	Stainless steel (Q variant)	x		x	x	Observe content of abrasives in the pumped liquid.
	White cast iron (W variant)		x			Observe free passage through pump or consider pre-screening of water.
Storm water	Grey cast iron	x		x	x	
	Stainless steel (Q variant)	x		x	x	
	White cast iron (W variant)		x			

Liquid description	Recommended material grade	Open S-tube® hydraulics without guide vane (standard)	Open S-tube® hydraulics with guide vane (optional)	Closed S-tube® hydraulics	Supervortex hydraulics	Recommendations
Wastewater						
Domestic wastewater from buildings	Grey cast iron	x		x	x	
	Stainless steel (Q variant)	x		x	x	
	White cast iron (W variant)		x			
Untreated municipal wastewater	Grey cast iron	x		x	x	
	Stainless steel (Q variant)	x		x	x	
	White cast iron (W variant)		x			
High head/low flow wastewater handling	Grey cast iron	x		x	x	Observe and consider: Local legislation and free passage through pump e.g. EN 12050.
	Stainless steel (Q variant)	x		x	x	
	White cast iron (W variant)		x			Open S-tube® hydraulics available with guide vane to swipe fibers away (optional solution).
Wastewater with long fibrous material	Grey cast iron	x		x	x	Content of abrasives in the pumped liquid.
	Stainless steel (Q variant)	x		x	x	Operational time and hydraulic efficiency.
	White cast iron (W variant)		x			The need for ceramic-coated pumps (optional).
Wastewater with abrasive/unsuspended solids (dry matter content up to 3%)	Grey cast iron	x		x	x	
	Stainless steel (Q variant)	x		x	x	
	White cast iron (W variant)		x			
Wastewater with abrasive/unsuspended solids (dry matter content up to 5%)	Grey cast iron	x		-	x	
	Stainless steel (Q variant)	(x)		-	x	
	White cast iron (W variant)		x			
Sludge						
Raw sludge with dry matter content up to 4% (un-screened)	Grey cast iron			x	x	x
	Stainless steel (Q variant)			x	x	x
	White cast iron (W variant)				x	
Digested sludge with dry matter content up to 4-5% depending on screening	Grey cast iron			x	x	x
	Stainless steel (Q variant)			x	x	x
	White cast iron (W variant)				x	
Activated sludge with dry matter content up to 4-5% depending on screening	Grey cast iron			x	x	x
	Stainless steel (Q variant)			x	x	x
	White cast iron (W variant)				x	

Liquid description	Recommended material grade	Open S-tube® hydraulics without guide vane (standard)	Open S-tube® hydraulics with guide vane (optional)	Closed S-tube® hydraulics	Supervortex hydraulics	Recommendations
Industrial wastewater containing:						
Suspensions like paint, lacquer and varnish	Grey cast iron	x		x	x	Observe and consider: Operating conditions when selecting optimal hydraulic variant. Open S-tube® hydraulics available with guide vane to swipe fibers away (optional solution).
	Stainless steel (Q variant)	x		x	x	
	White cast iron (W variant)		x			
Acidic wastewater (down to pH 6.5)	Grey cast iron	x		x	x	Operational time and hydraulic efficiency. Content of abrasives in the pumped liquid The need for ceramic-coated pumps (optional).
	Stainless steel (Q variant)	x		x	x	
	White cast iron (W variant)		x			
Basic wastewater (up to pH 14)	Grey cast iron	x		x	x	The need for alternative seal face materials in shaft seals, contact Grundfos.
	Stainless steel (Q variant)	x		x	x	
	White cast iron (W variant)		x			
Highly abrasive industrial effluent causing wear						
Lime water	Grey cast iron			(x)	(x)	x
	Stainless steel (Q variant)			(x)	(x)	x
	White cast iron (W variant)				(x)	
Lime milk containing quartz and pigment suspensions	Grey cast iron			(x)	(x)	x
	Stainless steel (Q variant)			(x)	(x)	x
	White cast iron (W variant)				(x)	
Effluent industrial wastewater containing solids	Grey cast iron			(x)	(x)	x
	Stainless steel (Q variant)			(x)	(x)	x
	White cast iron (W variant)				(x)	
Effluent industrial wastewater containing high content of dust and ashes	Grey cast iron			(x)	(x)	x
	Stainless steel (Q variant)			(x)	(x)	x
	White cast iron (W variant)				(x)	

Additional water types					
Brackish water	Grey cast iron	x	x	x	Material variants depend on both temperature and chloride content of brackish water, see brochure titled "GRUNDFOS SL, SE, S PUMP VARIANTS, 1.1 - 520 kW (Product brochure)" (publication no. 97745765) available in Grundfos Product Center.
	Stainless steel (Q variant)	x	x	x	
	White cast iron (W variant)		x		
Sea water	Grey cast iron	x	x	x	Observe the need for cathodic protection and coating of the pump.
	Stainless steel (Q variant)	x	x	x	
	White cast iron (W variant)		x		

Legend

x	Recommended choice
(x)	Optional, contact Grundfos.

Basic pump configuration

- See Type Key to identify the pump specification.

Example: Product name	
Pump type: Sewage pump with cooling jacket	SE
Impeller type: 1-channel, closed S-tube®	1.
Pump free passage: 4.5"	45.
Pump outlet: 8"	A80.
Power: 27.0 hp	270.
Sensor version: Standard pump or standard Ex pump	
Number of poles: 4-pole motor	4

Features of a standard pump:

- 49 ft cable
- paint: NCS 9000N, RAL 9005 (black), average thickness 150 µm

- three thermal switches, one in each phase, or three thermal sensors (PTC)
- one moisture switch below the motor top cover
- one level switch in the leakage chamber for standard pumps
- one leakage switch in the stator housing for standard Ex pumps
- tested according to centrifugal pump test ANSI/HI 11.6:2022, 3B.

For selection of a standard pump see Performance curves and technical data .

Note: For further information on technical data, visit the Grundfos Product Center.

Variants of customized pumps

Motor		
Various cable lengths	Cable length depends on motor size and power supply.	49 ft, standard
		82 ft
		98 ft
		164 ft
		33 ft
EMC power cables	Screened power cables for variable-speed drives. Cable length depends on motor size and power supply. See the notification on the EMC cables in the Product description.	49 ft
		82 ft
		98 ft
		164 ft
Special motor	Special voltage is available on request.	Contact Grundfos.
PTC thermistors in windings		

Motor protection	
Thermal switch/PTC + moisture switch + level switch	Standard
Thermal switch/PTC + moisture switch + leakage switch	Standard Ex. version
Thermal switch/PTC + moisture switch + Pt1000 + level switch	Sensor version 1
Thermal switch/PTC + moisture switch + Pt1000 + leakage switch	Sensor Ex. version 1
Thermal switch/PTC + moisture switch + Pt1000 + PVS3 + SM 113 and IO 113 ⁴⁾ + level switch	Sensor version 2
Thermal switch/PTC + moisture switch + Pt1000 + PVS3 + SM 113 and IO 113 ⁴⁾ + leakage switch	Sensor Ex. version 2

4) IO 113 is not part of the pump delivery. It must be ordered separately.

Tests ⁵⁾	
Test at specified duty point based on standard impeller/curve	
Trimmed impeller for specified duty test	Only for SuperVortex and Open S-tube® impellers
Duty point verification report (according to ANSI/HI 11.6:2022 grade 3B)	Duty point verification test guaranteed by Grundfos
Duty point verification report (according to ANSI/HI 11.6:2022 grade 2B and 2U)	Duty point verification test guaranteed by Grundfos
Duty point verification report (according to ANSI/HI 11.6:2022 grade 1B and 1U)	Duty point verification test guaranteed by Grundfos
Performance test report (according to grade 3B)	12-42 hp

Tests ⁵⁾	
Performance test report (according to grade 2B and 2U)	12-42 hp
Performance test report (according to grade 1B, 1E and 1U)	12-42 hp
Witness test	

⁵⁾ For tests and test reports, contact Grundfos.

Note: Test requests must be specified upon ordering.

Certificates ⁶⁾		
FM-approved-pump report	Special Grundfos report	
Certificate of compliance with order	According to EN10204 2.1	According to ANSI/HI 11.6:2022 3B
Impeller balancing certificate		
Pump certificate	According to EN10204 2.2	According to ANSI/HI 11.6:2022 3B
Inspection certificate	According to EN10204 3.1	According to ANSI/HI 11.6:2022 3B
Material specification report	According to EN10204 3.1B	
Material report with certificate	According to EN10204 3.2	Material supplier information
Hydrostatic pressure test certificate		According to ANSI/HI 11.6:2022 3B
Painting certificate (including verification of painting thickness)		
Electric motor test report certificate		
Inspection certificate, Lloyds Register	According to EN10204 3.2	
Inspection certificate, DNV (Det Norske Veritas)	According to EN10204 3.2	
Inspection certificate, Germanischer Lloyd	According to EN10204 3.2	
Inspection certificate, American Bureau of Shipping	According to EN10204 3.2	
Inspection certificate, Bureau Veritas	According to EN10204 3.2	
Registro Italiano Navale Agenture	According to EN10204 3.2	
Other third-party test certificates		

⁶⁾ For certificates, contact Grundfos.

Miscellaneous ⁷⁾	
Duplex stainless-steel impeller according to AISI 316 (EN1.4517)	Increased resistance to abrasive liquids
FKM sealing (optional)	Resistant to acids
	Resistant to mineral- and vegetable oils Resistant to most solvents, such as toluene, petrol, trichloroethylene
Cable protection hose	Resistant to acids
	Resistant to most oils
	Resistant to most solvents
Ceramic coating of impeller ⁸⁾ and pump housing	Reduced wear rate of cast iron parts
	Increased corrosion resistance
	Beneficial in case of low number of operating hours
Extra epoxy coating, 300 µm or 450 µm	Increased corrosion resistance
Top coating (black RAL 9005, red RAL 3000 and other colors)	
Special packaging	
Special nameplate	
Other variants	

⁷⁾ For miscellaneous variants, contact Grundfos.

⁸⁾ Only available for Closed S-tubes.

Flange forces

The flange forces and moments comply with EN ISO 5199. See forces for both horizontal and vertical installations in EN ISO 5199, Table B.3 by selecting the correct flange dimension. Forces cannot be used directly for end-suction wastewater pumps without using a coefficient. See it in EN ISO 5199, Table B.5 by selecting the correct pump family. For Grundfos wastewater pumps, the pump families and coefficients are stated below.

Horizontally installed pumps	
Pump family A4	coefficient 0.35
Vertically installed pumps	
Pump family 10A	coefficient 0.30

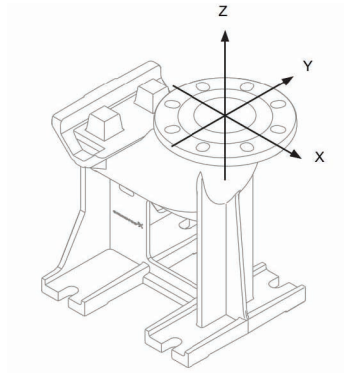

TM079281

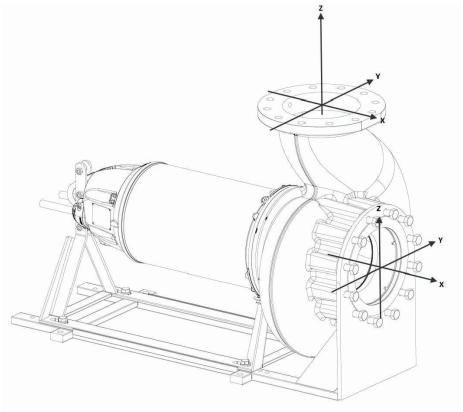

TM079279

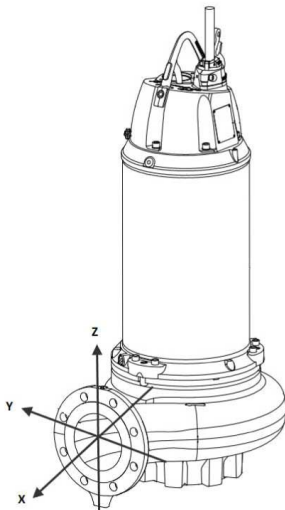

TM079280

6. Construction

Sectional drawings, motors

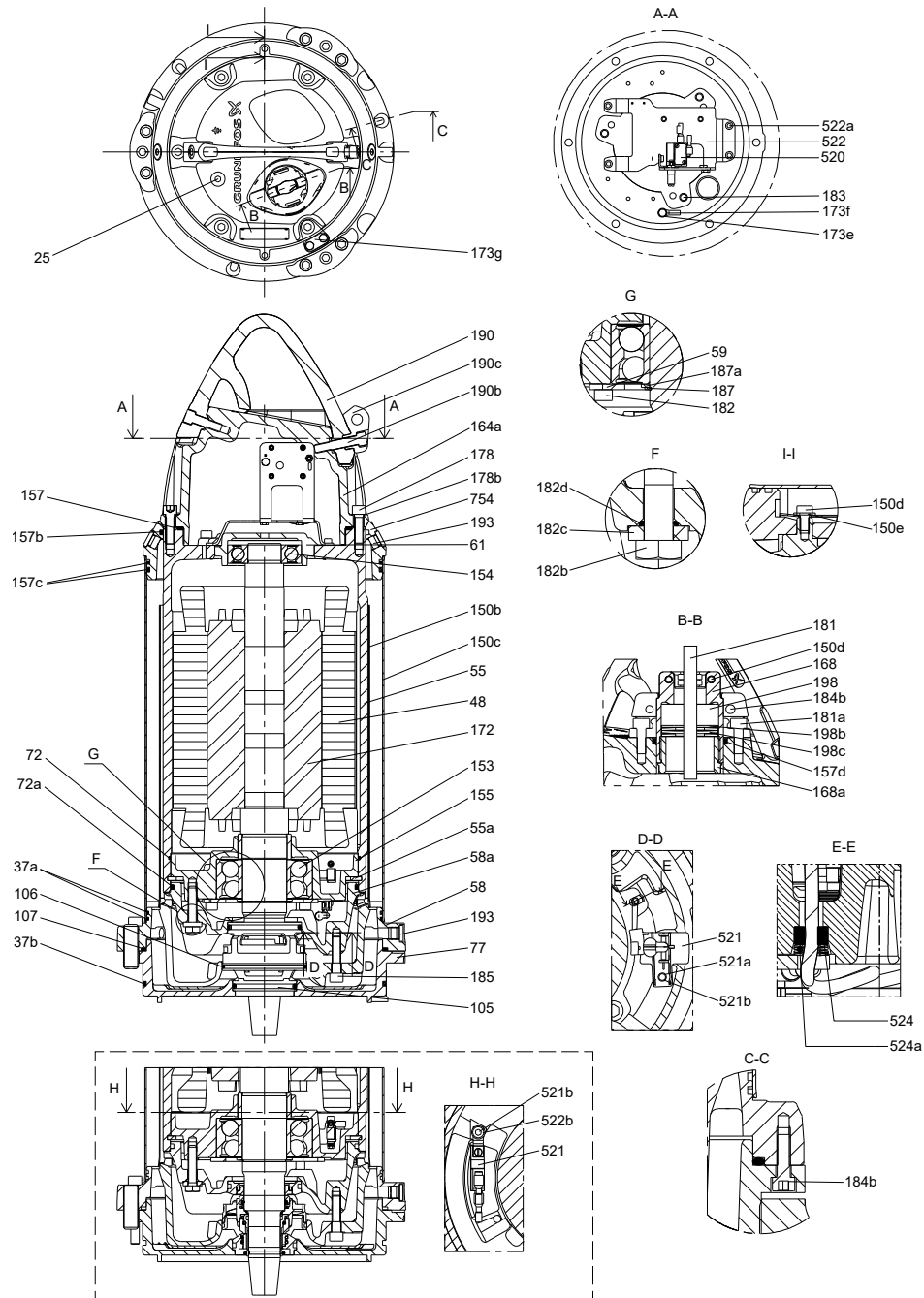

SE pump with cooling jacket (2- and 4-pole motors) (H-H: Explosion proof version)

TM088900

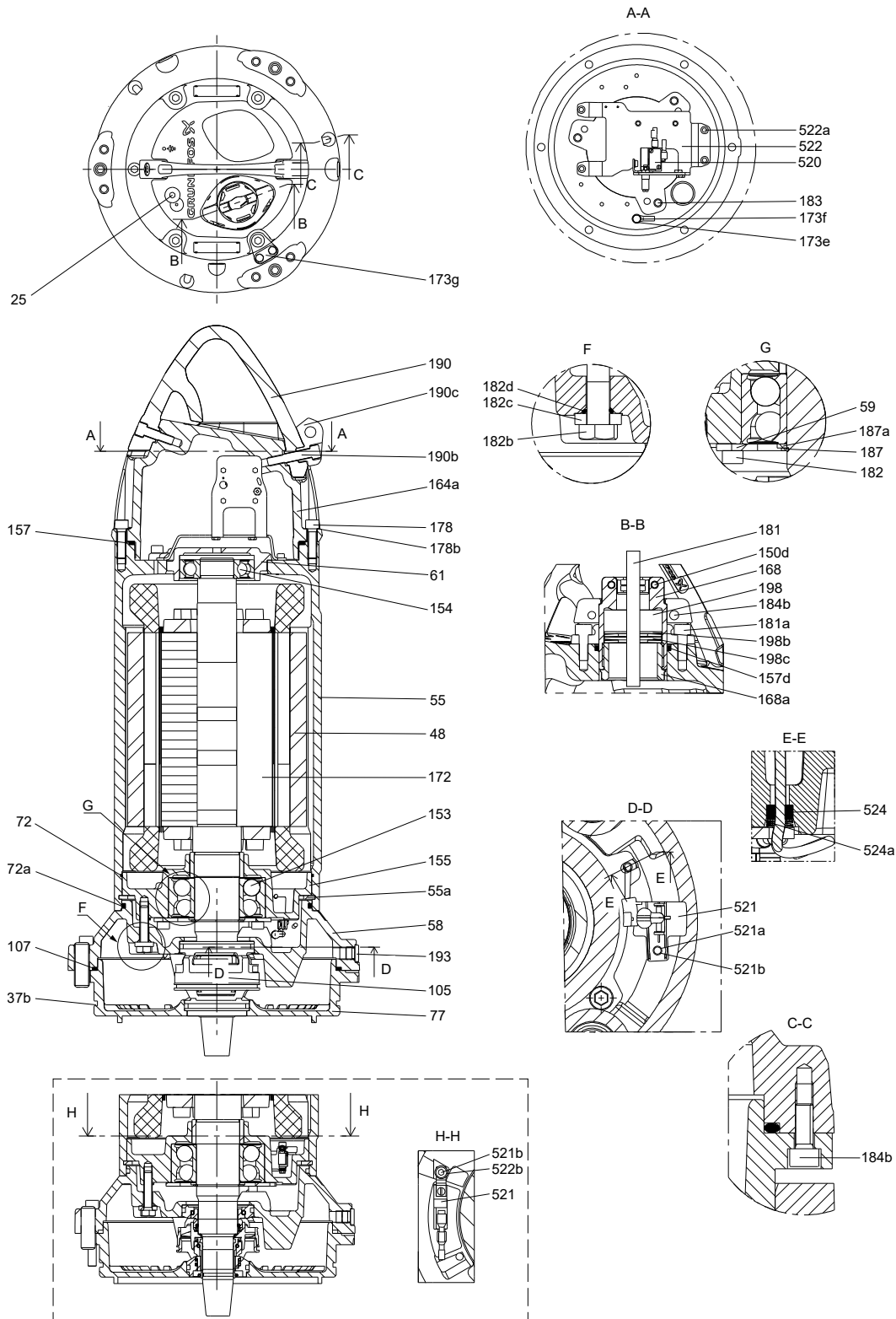

TM088901

SL pump without cooling jacket (2- and 4-pole motors) (H-H: Explosion proof version)

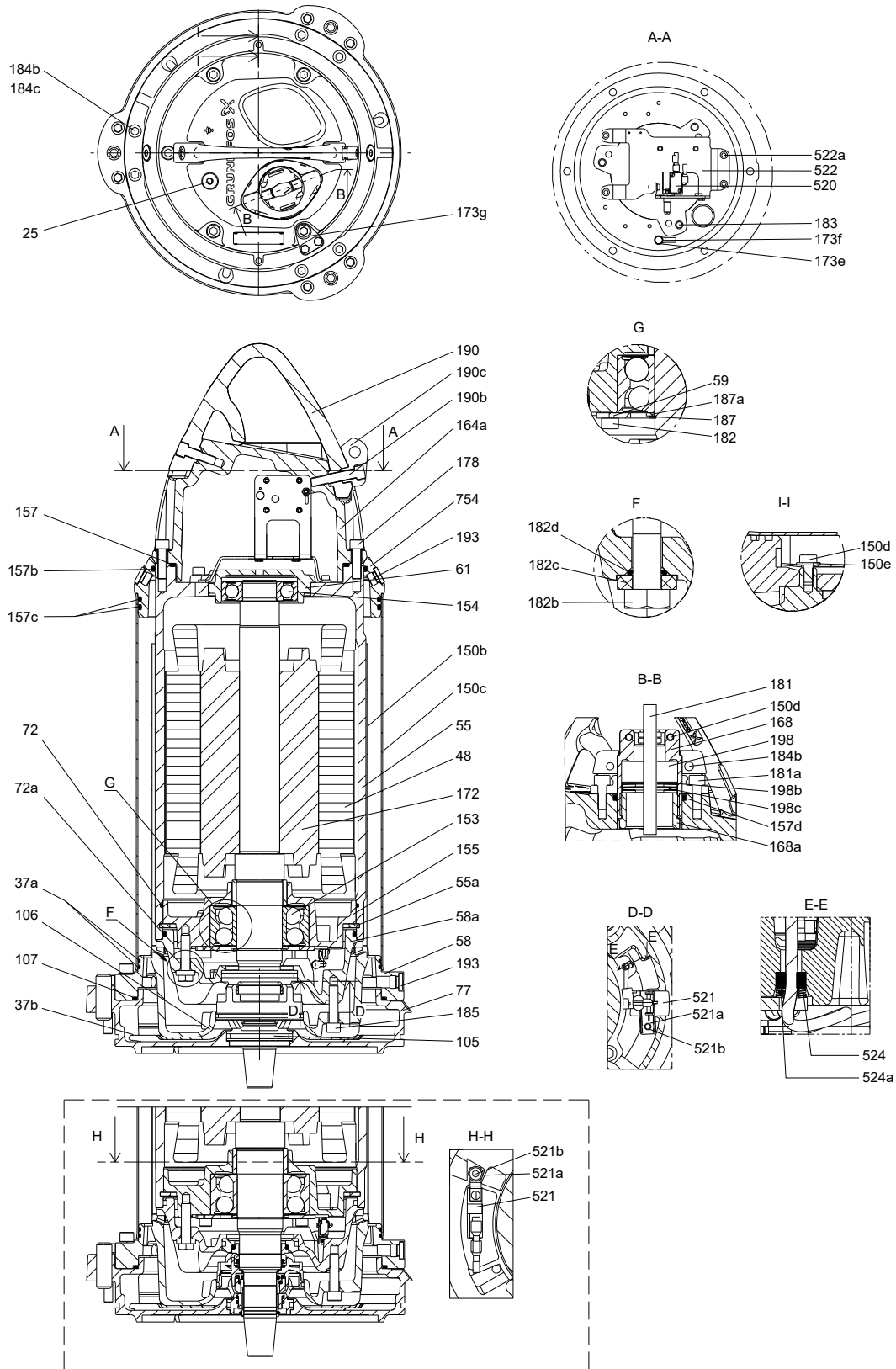

TM088902

SE pump with cooling jacket (6-pole motors) (H-H: Explosion proof version)

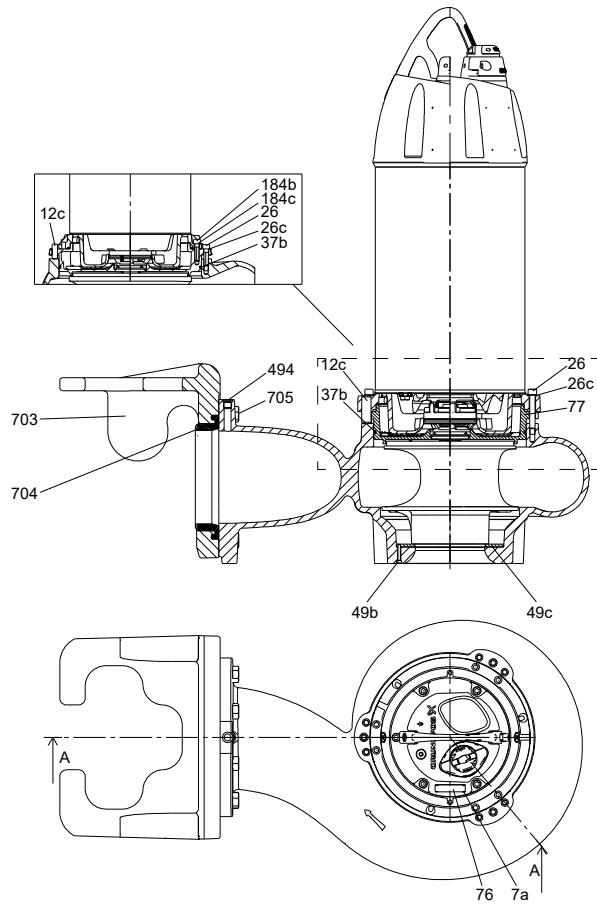

SE pump with guide claw (6-pole motors)

TM076051

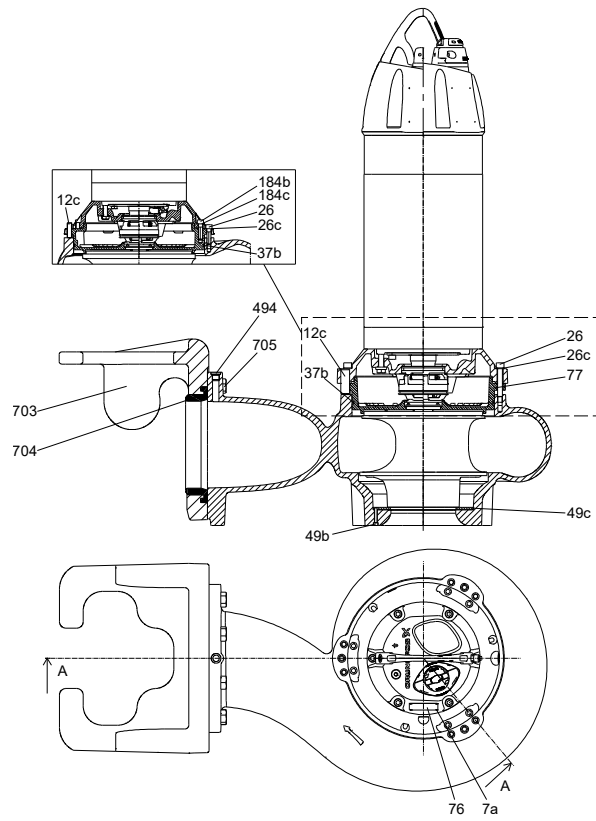

TM076052

SL pump with guide claw (6-pole motors)

Sectional drawings, pumps

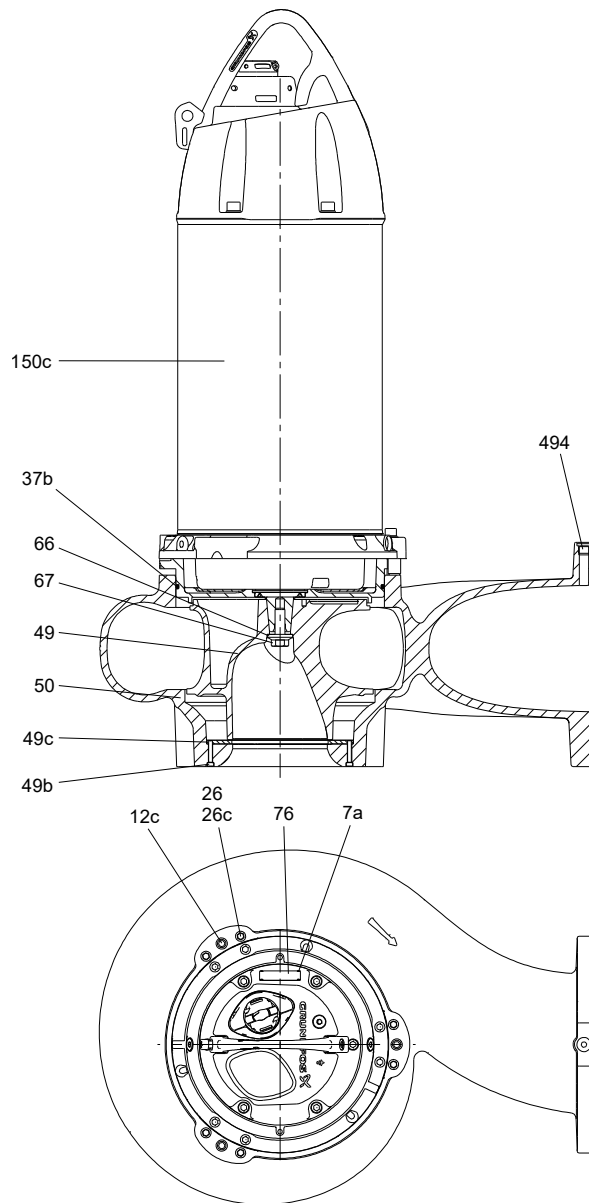

SE pump, with closed S-tube® impeller

TM076040

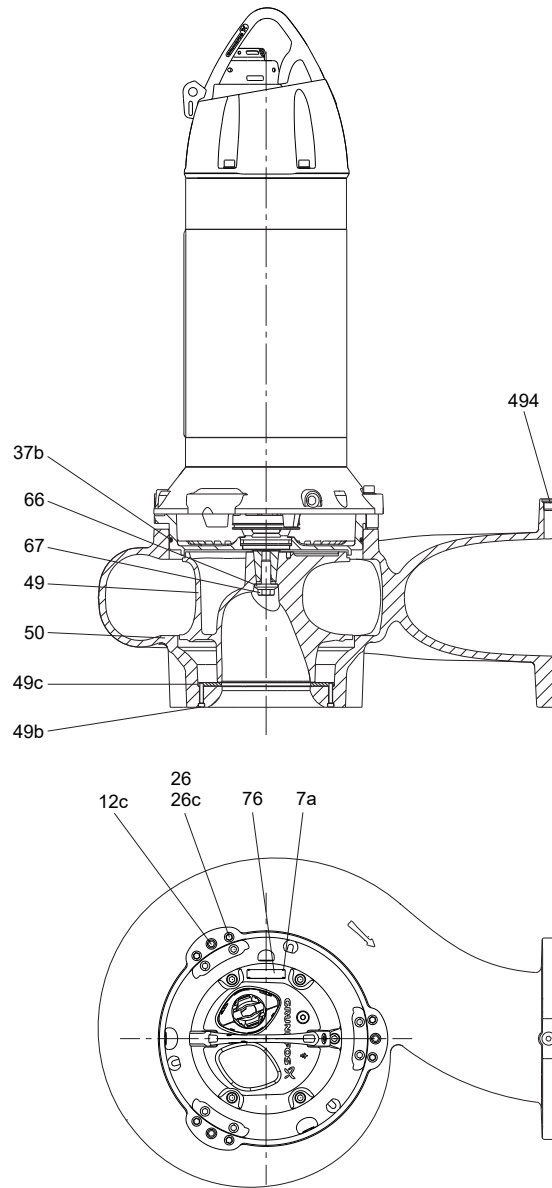

TM076041

SL pump, with closed S-tube[®] impeller

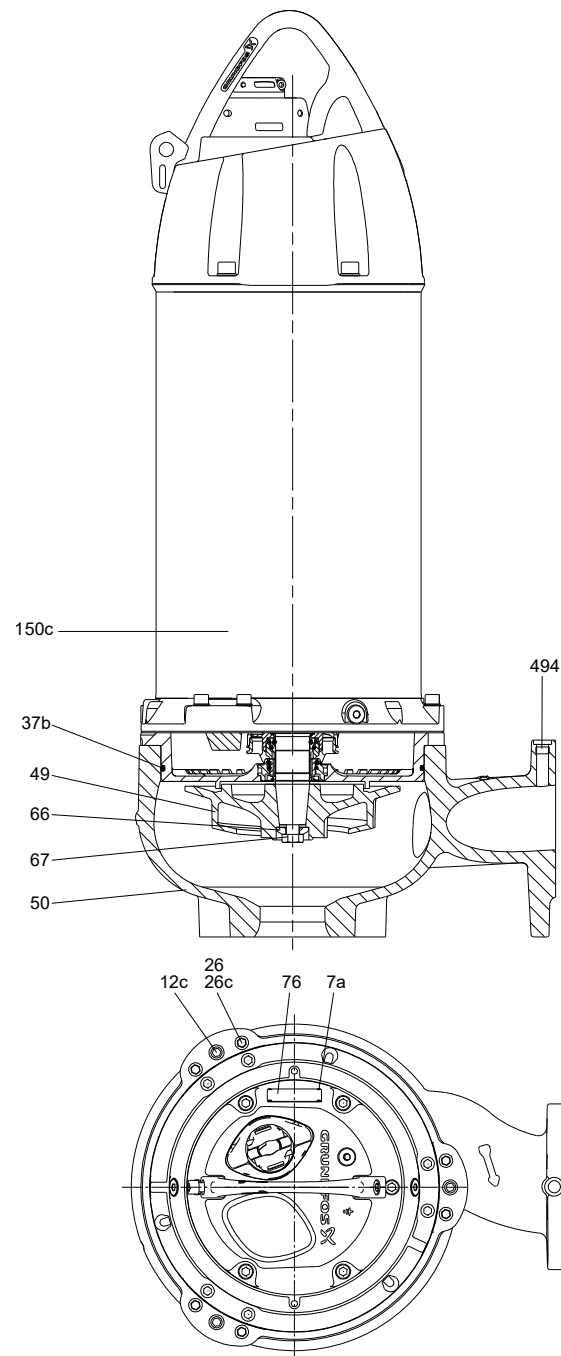

SE pump, with SuperVortex impeller

TM076042

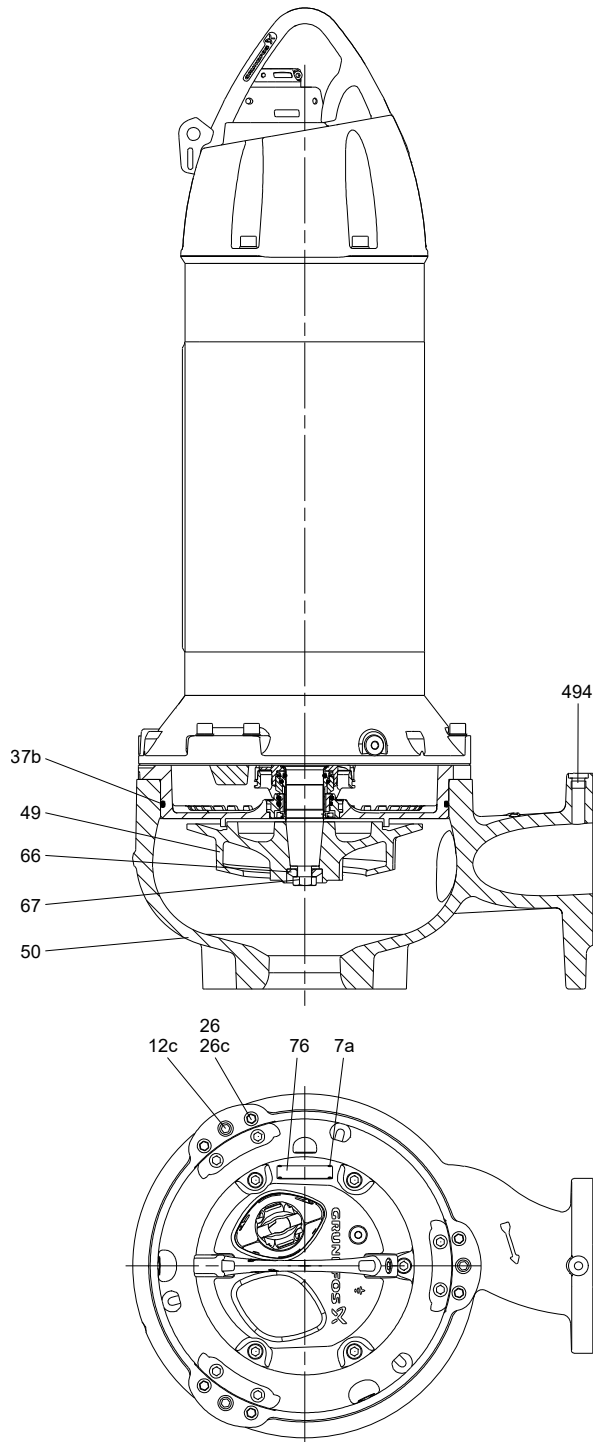

SL pump, with SuperVortex impeller

TM076043

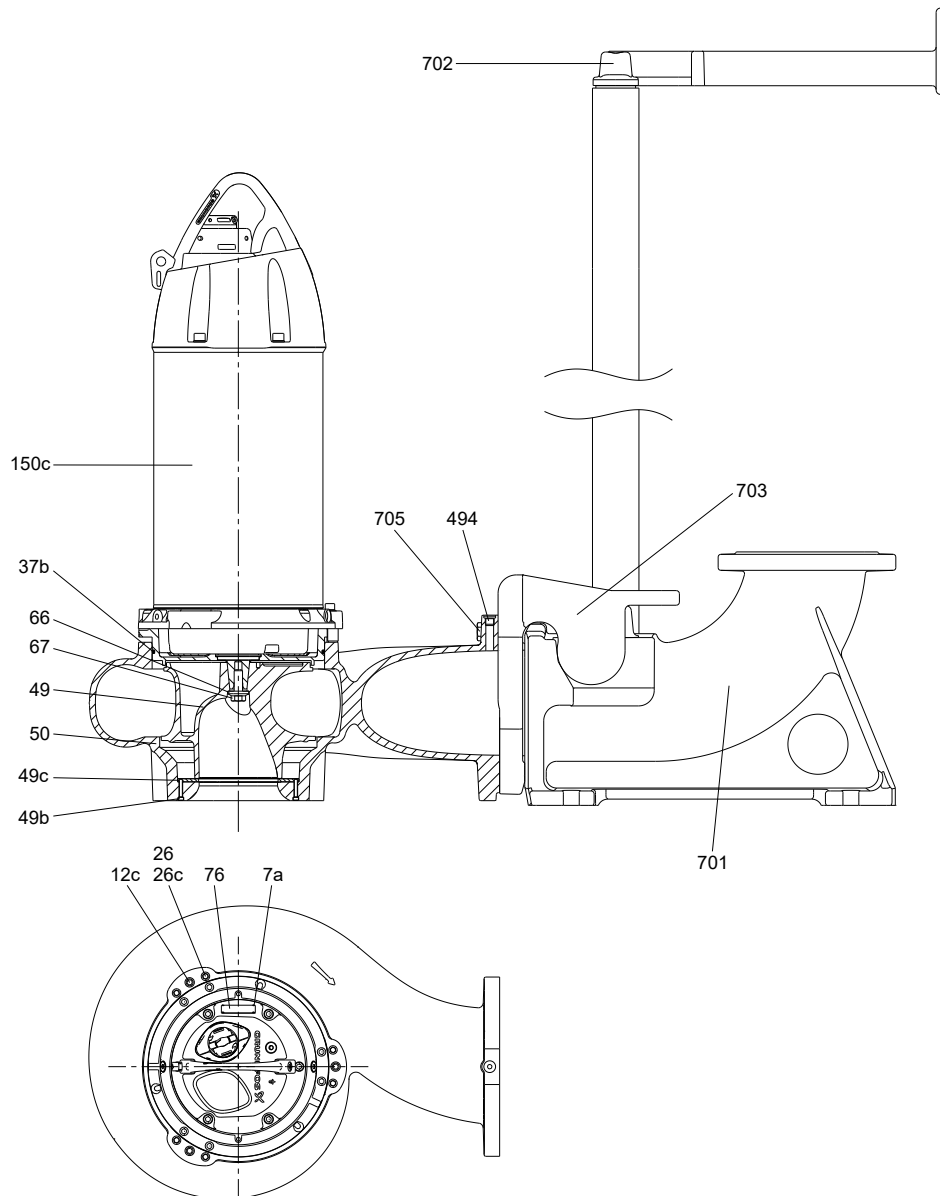

SE pump, with guide claw for auto-coupling

TM076044

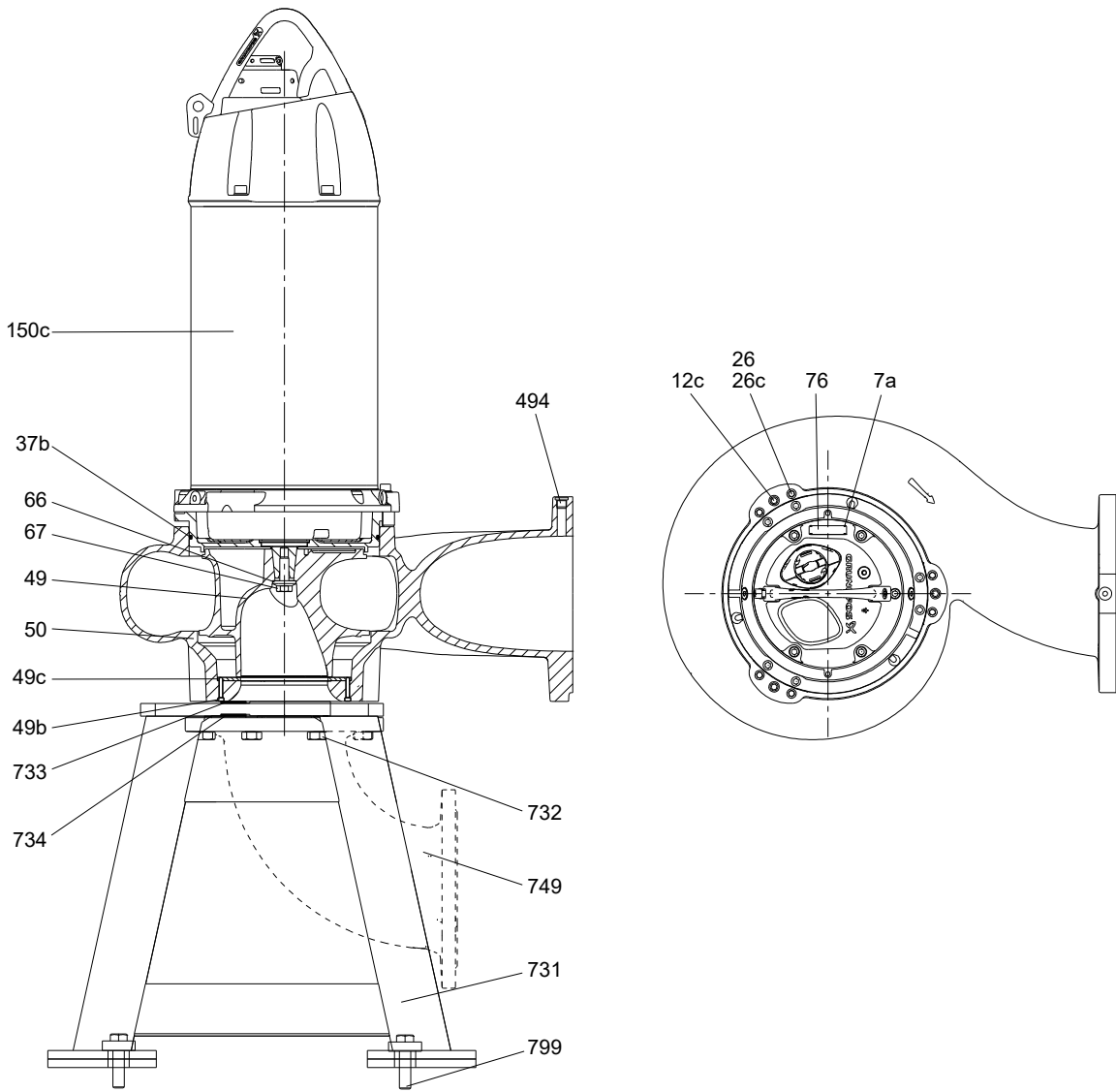

SE pump, dry installation on vertical base stand (recommended for SE pumps below 20 Hp)

TM076045

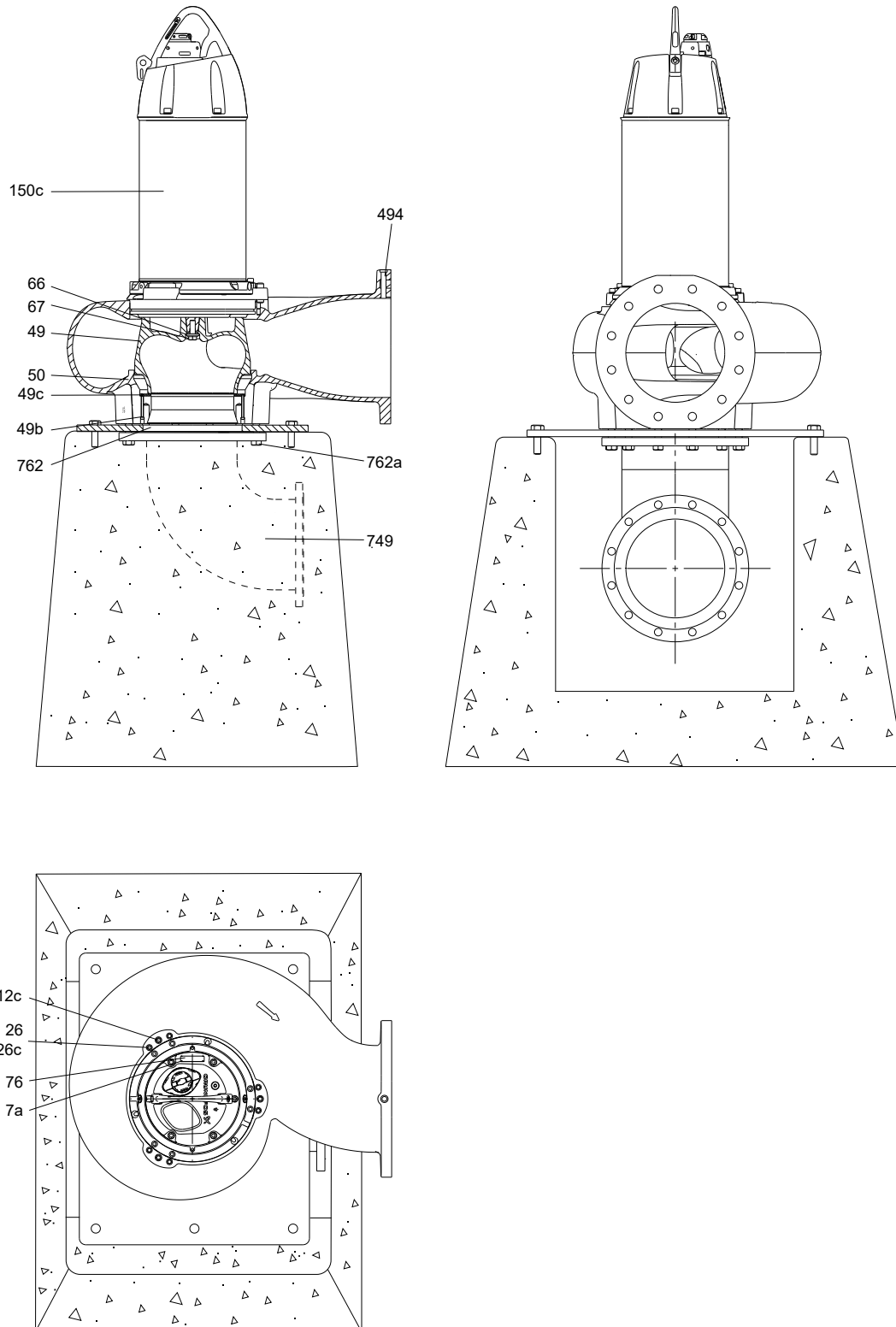

SE pump, dry installation on concrete foundation (recommended for SE pumps from 20 Hp and above)

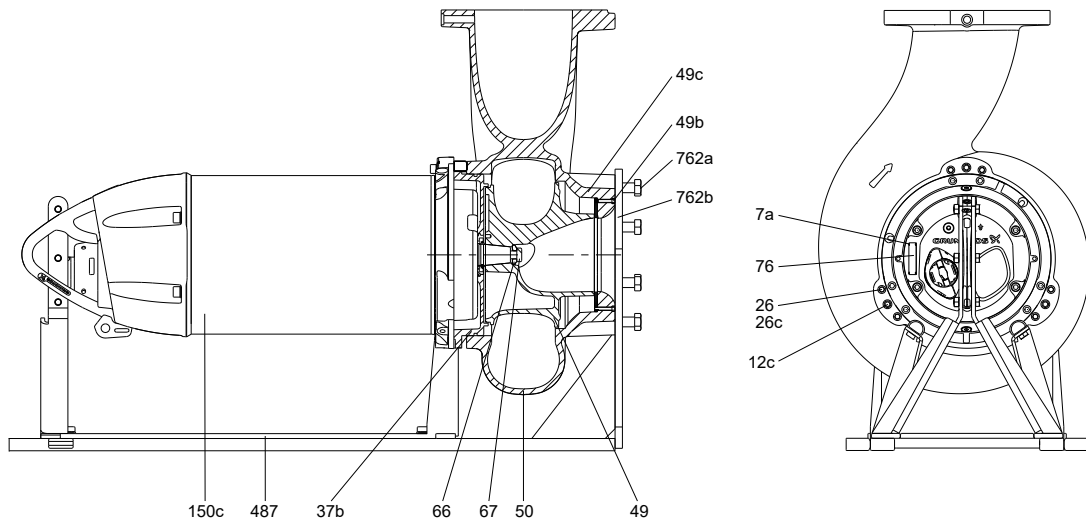

TM076047

SE pump, dry installation on horizontal base stand

Exploded views

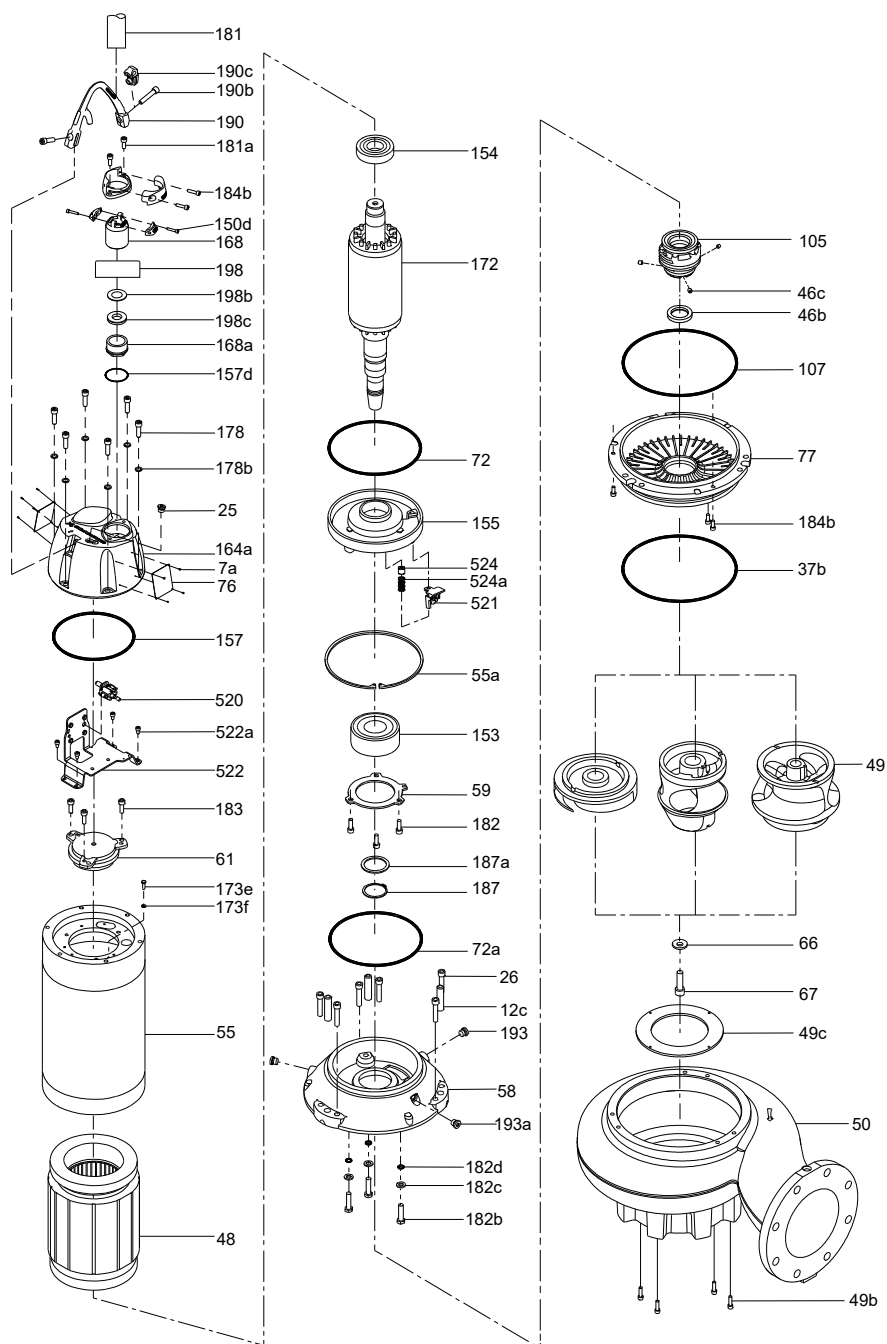

SLV, SL, SL1, SL2 pumps, 2-4 poles

TM075456

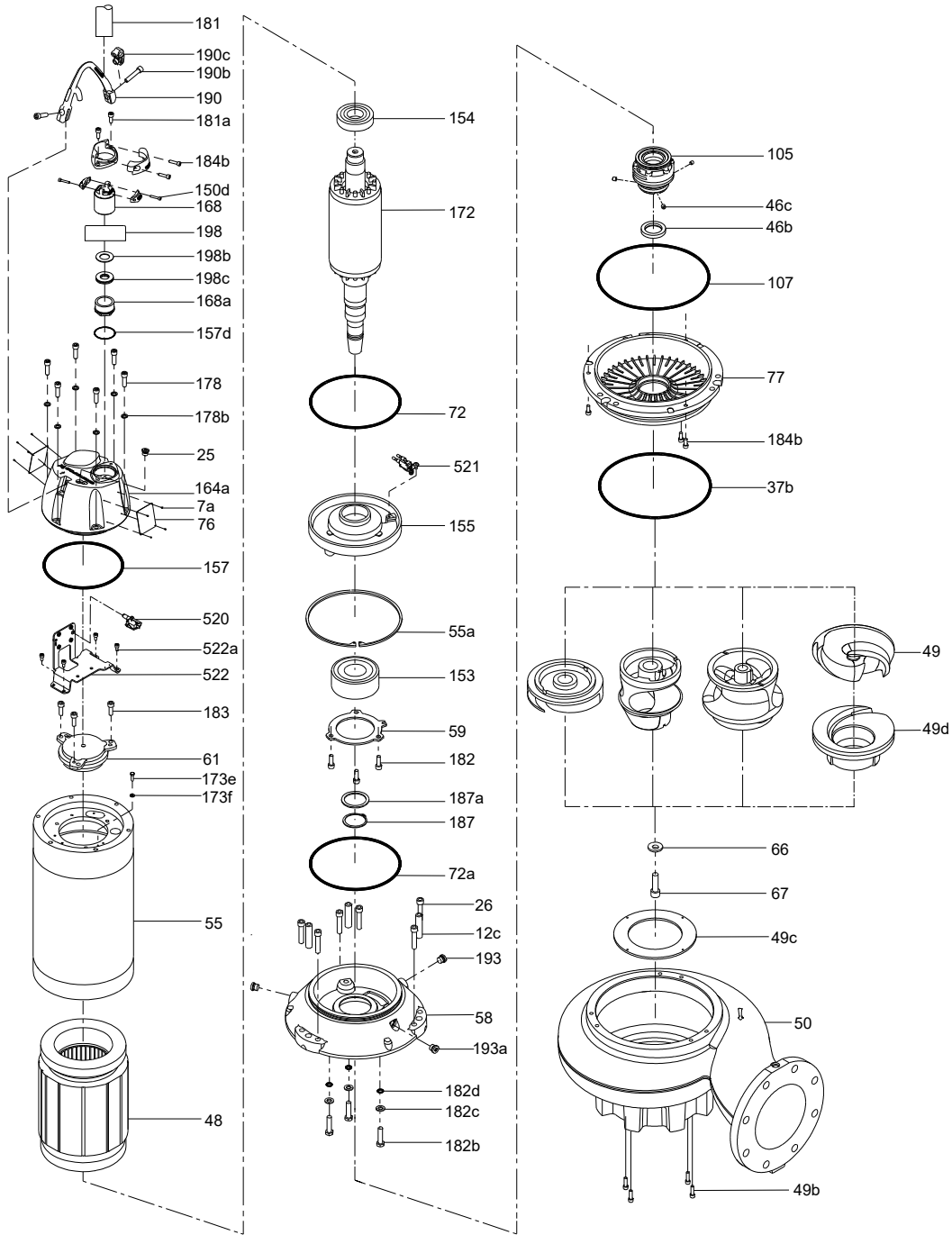

TM088888

SLV Ex, SL Ex, SL1 Ex, SL2 Ex pumps, 2-4 poles

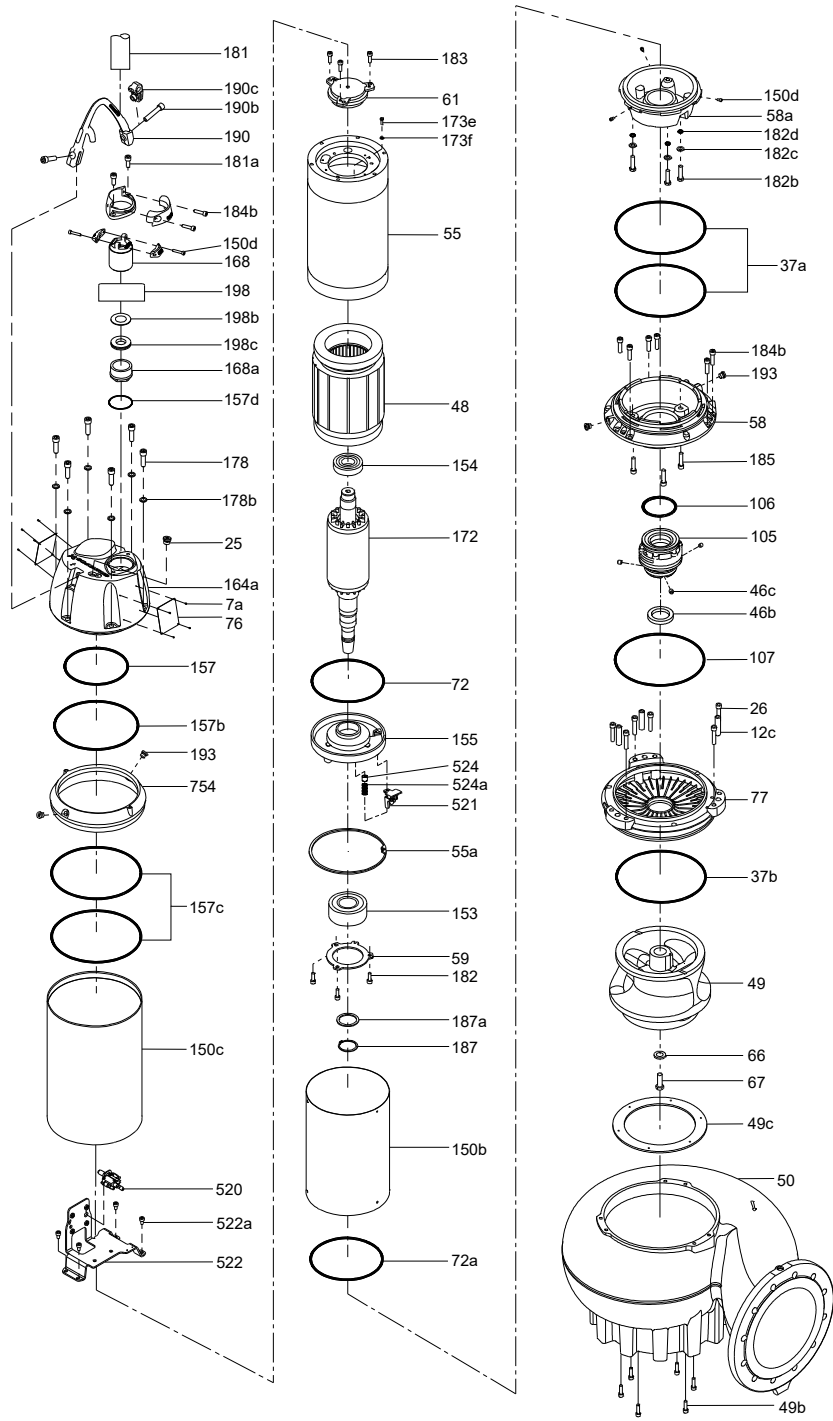

SE2 pumps, 6 poles

TM075458

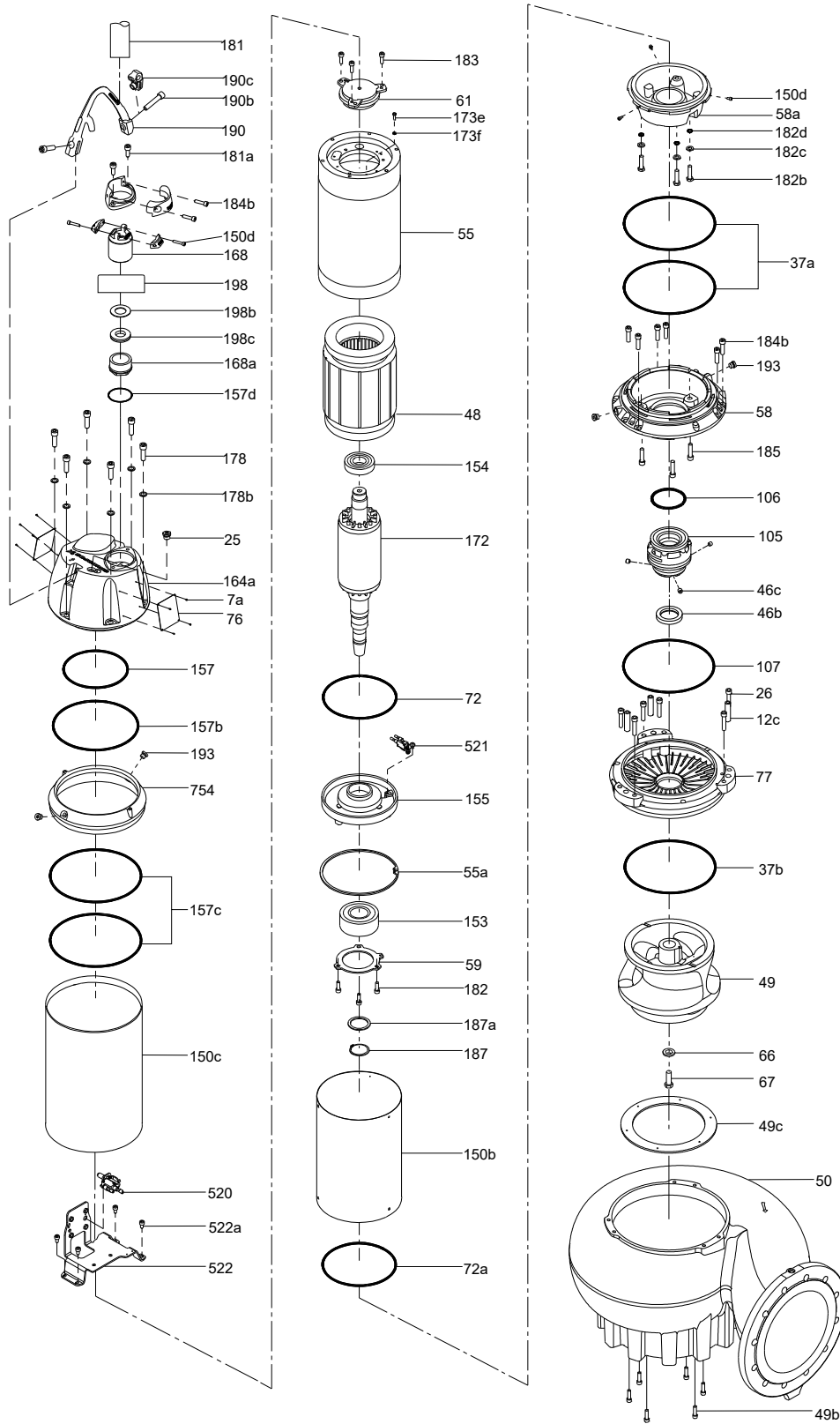

SE2 Ex pumps, 6 poles

TM088889

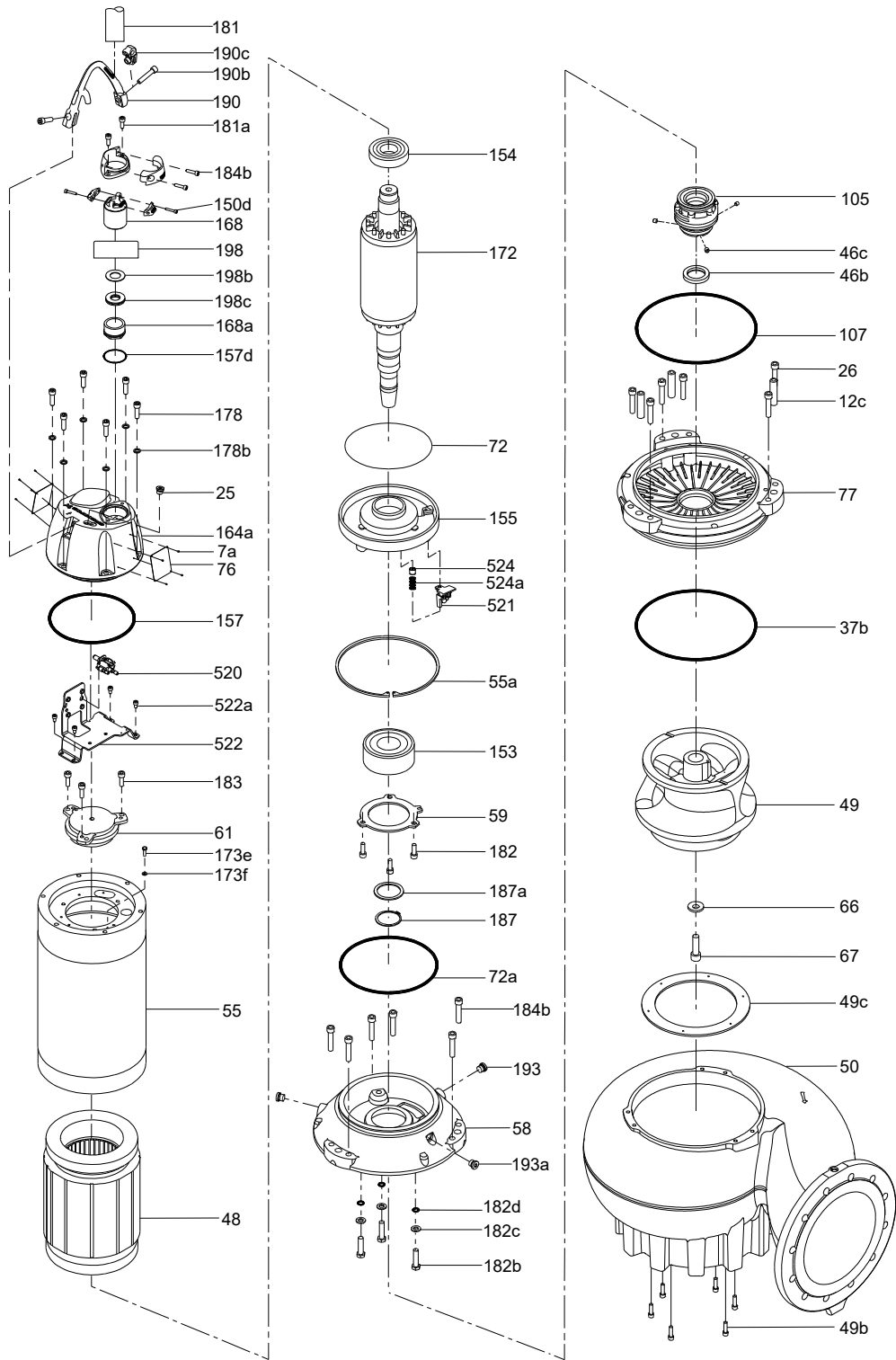

SL2 pumps, 6 poles

TM075460

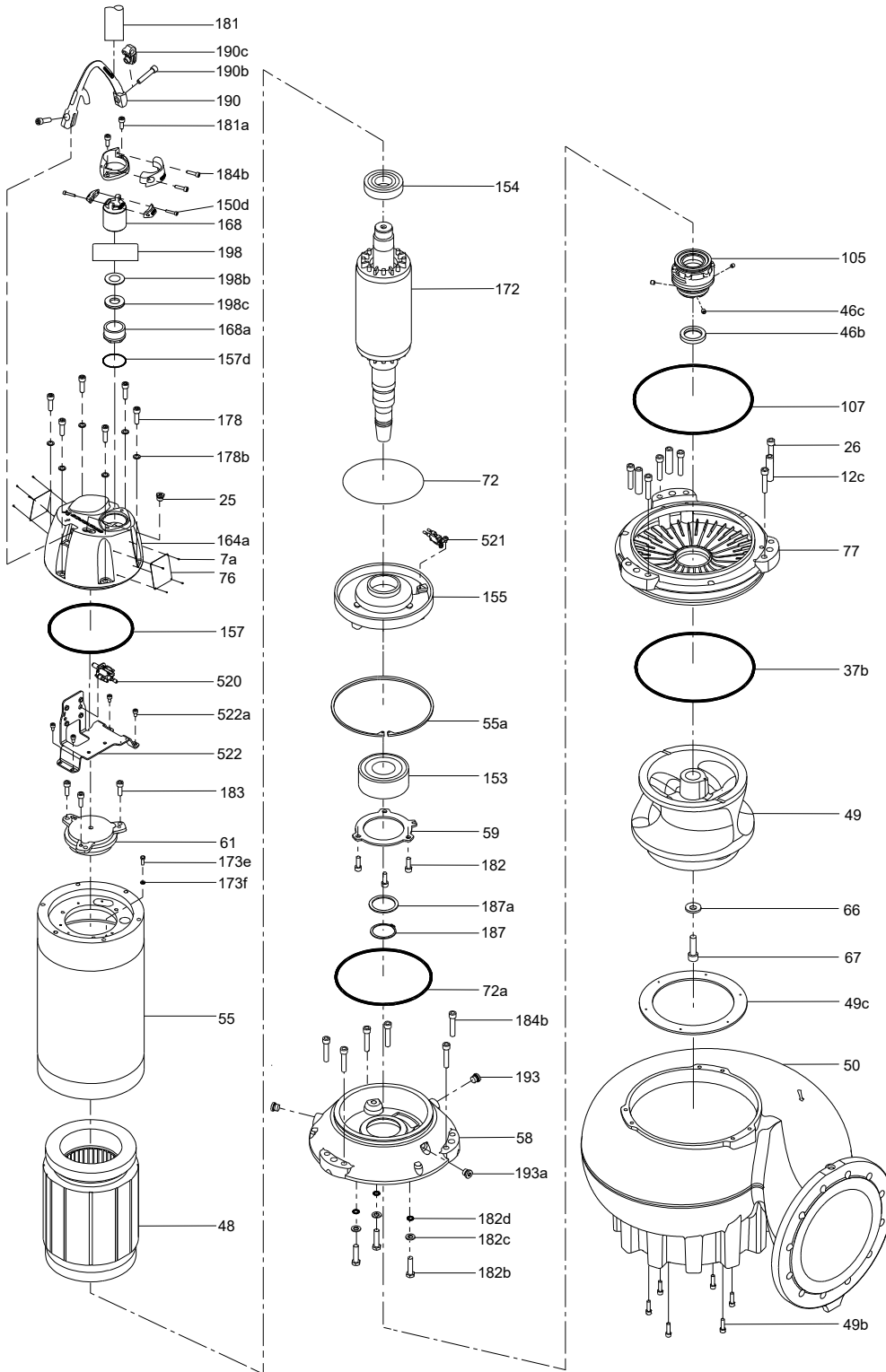

SL2 Ex pumps, 6 poles

TM088690

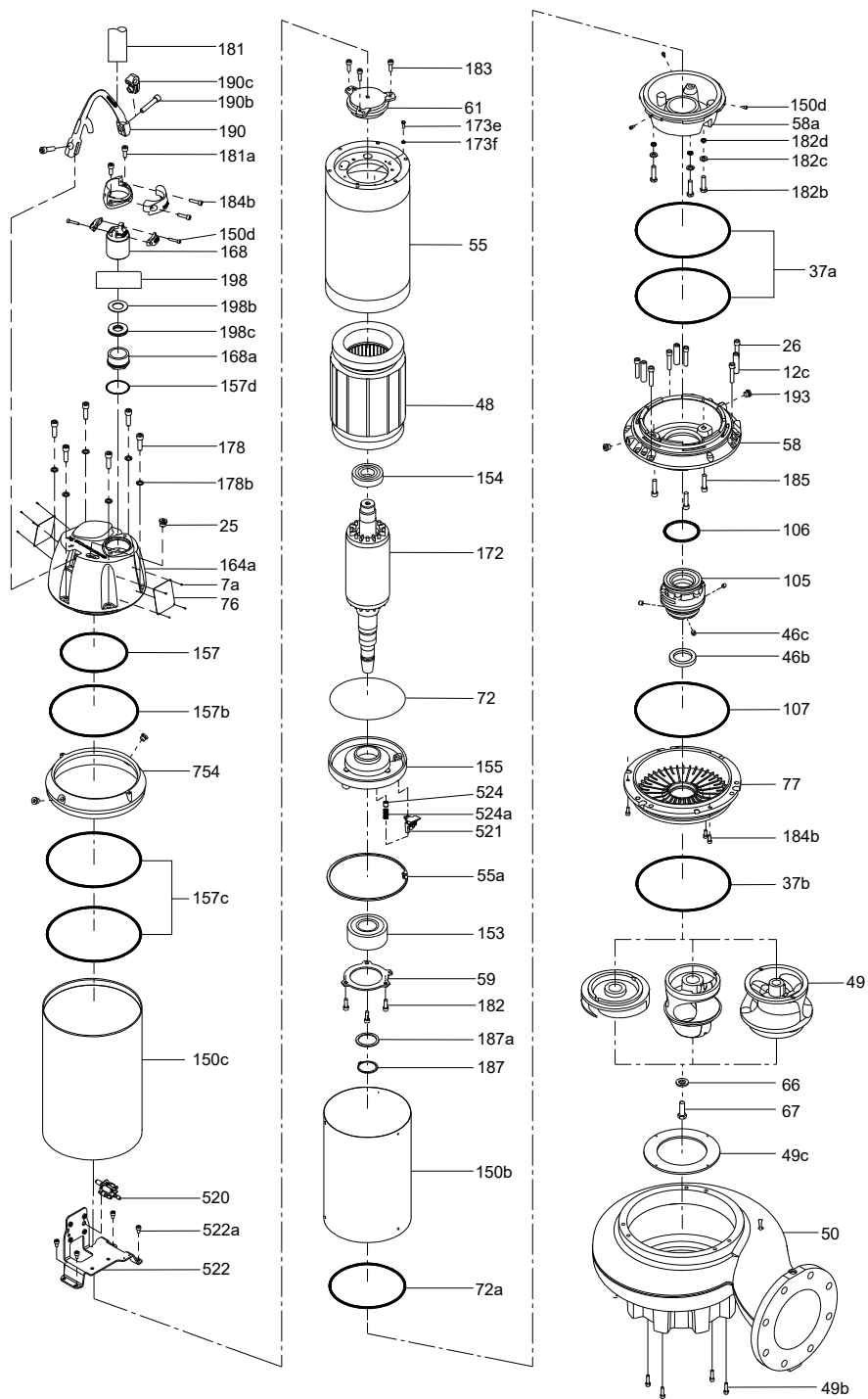

SEV, SE, SE1, SE2 pumps, 2-4 poles

TM075462

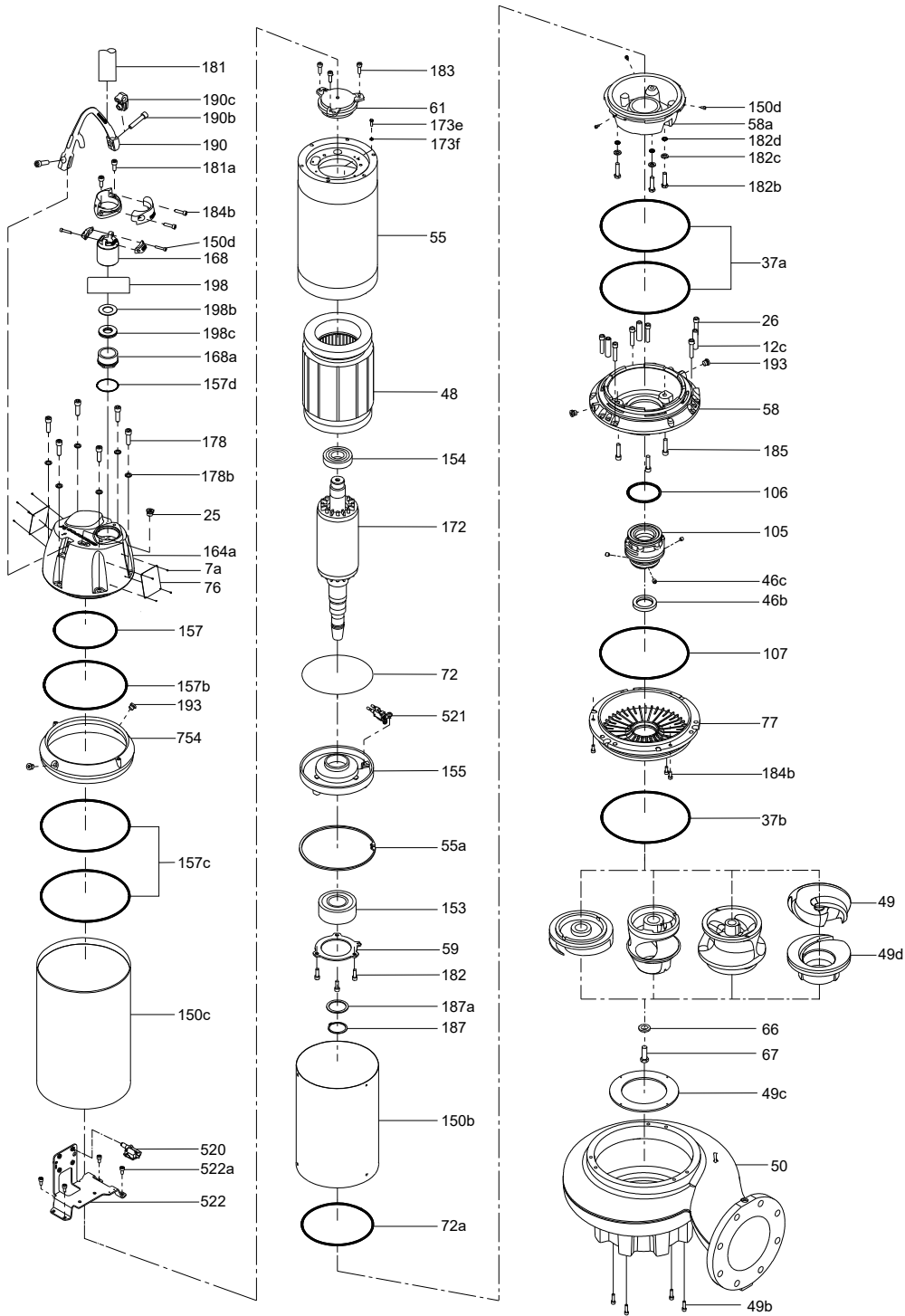

TMO88891

SEV Ex, SE Ex, SE1 Ex, SE2 Ex pumps, 2-4 poles

Components and material specification

The position numbers in the table below refer to the sectional drawings on the previous pages.

Motor components

Pos.	Component	Material	DIN W.-No./ EN standard	AISI/ ASTM
12c	Adjusting screw	Stainless steel	1.4436	316
25	Pressure test plug	Stainless steel	1.4436	316
25a	Screw	Stainless steel	1.4436	316
25b	Lock washer	Stainless steel	1.4436	316
26	Screw	Stainless steel	1.4436	316
26c	Washer	Stainless steel	DIN 433	
37a	O-ring	NBR rubber		
37b	O-ring	NBR rubber		
46b	Lip seal			
46c	Screw			
48	Stator lamination			
55	Stator housing	Cast iron	EN-JL-1040	ASTM A48 Class 40B
55a	Circlip	DIN 472		
58	Intermediate seal housing (SE) Upper seal housing (SL)	Cast iron	EN-JL-1040	ASTM A48 Class 40B
58a	Upper seal housing cover	Cast iron	EN-JL-1040	ASTM A48 Class 40B
59	Bearing bracket cover	Cast iron	EN-JL-1040	ASTM A48 Class 40B
61	Upper bearing bracket	Cast iron	EN-JL-1040	ASTM A48 Class 40B
66	Impeller washer	Stainless steel	1.4436	316
67	Impeller screw	Stainless steel	1.4436	316
72a	O-ring	NBR rubber		
77	Lower seal housing			
105	Shaft seal cartridge cpl.	SiC/SiC or SiC/ carbon A		
106	O-ring for shaft seal			
107	O-ring	NBR rubber		
150b	Inner cooling jacket			
150d	Screw			
150e	Washer	Stainless steel	DIN 433	
153	Ball bearing	Stainless steel		
154	Ball bearing	Stainless steel		
155	Lower bearing bracket	Cast iron	EN-JL-1040	ASTM A48 Class 40B
157	O-ring	NBR rubber		
157b	O-ring	NBR rubber		
157d	O-ring	NBR rubber		
157c	O-ring	NBR rubber		
164a	Motor top cover	Cast iron	EN-JL-1040	ASTM A48 Class 40B
168	Cable entry	PA or cast iron		
168a	Cable entry lower			
168b	Cover for connector			

Pos.	Component	Material	DIN W.-No./ EN standard	AISI/ ASTM
172	Shaft with rotor	Stainless steel	1.4462	UNS31803
173e	Screw	Stainless steel	1.4436	316
173f	Spring washer	Stainless steel	1.4436	316
173g	External ground connector	Stainless steel	1.4436	316
176a	Terminal block			
176c	Plug housing			
178	Screw	Stainless steel	1.4436	316
178b	Washer	Stainless steel	DIN 433	
181a	Screw	Stainless steel	1.4436	316
181	Cable			
181b	EMC cable/shield			
182	Screw	Stainless steel	1.4436	316
182b	Hexagon socket head cap screw	Stainless steel	1.4436	316
182c	Washer			
182d	O-ring			
183	Screw			
184b	Screw	Stainless steel	1.4436	316
184c	Washer	Stainless steel	DIN 433	
185	Screw			
187	Circlip			
187a	Washer	Stainless steel	1.4436	316
190b	Screw	Stainless steel	1.4408	CF8M
190	Lifting bracket	Stainless steel	1.4408	CF8M
193	Plug	Stainless steel	1.4408	CF8M
198	Rubber seal			
198b	Washer			
198a	Washer			
198c	Disc spring			
520a	Screw	Stainless steel	1.4436	316
520	Upper moisture switch			
520c	Screw			
521	Level/Leakage switch			
521a	Washer	Zn DIN 127		
521b	Screw			
522	Bracket for moisture switch			
522b	Washer			
522c	Washer lock			
524	Rubber bush			
524a	Disc spring			
754	Cooling jacket ring			

Material declaration:

- Grey cast iron is manufactured according to EN 1561:1997.
- Cast stainless steel is manufactured according to EN 10283:2010.
- Conversion to other standards such as AISI/ASTM is normative, and products are not manufactured according to these.

Pump components

Pos.	Component	Material	DIN W.-No./EN standard	AISI/ASTM	
7a	Rivet				
12c	Adjusting screw	Stainless steel	1.4436	316	
26	Screw	Stainless steel	1.4436	316	
37	O-ring	NBR rubber			
37b	O-ring	NBR rubber			
49	Impeller (closed S-tube®)	Cast iron	EN-GJL-250	A48 35B	
		Stainless steel	1.4408	A351 CF8M	
			1.4517	316	
			1.4408	A351 CF8M	
		Impeller (open S-tube®)	Cast iron	EN-GJL-250	A48 35B
			Stainless steel	1.4408	A351 CF8M
	1.4517			316	
	White iron			EN 12513 EN-GJN-HB555 (XCr18)	A532 Class II B
	Impeller (SuperVortex)		Cast iron	EN-GJS-500-7	A536 grade 70-50-05
			Stainless steel	1.4408	A351 CF8M
		1.4517		316	
	49b	Screw			
49c	Wear ring	Carbon steel			
		Cast iron	EN-GJL-250	A48 35B	
		Stainless steel	1.4408	A351 CF8M	
		White iron	EN 12513 EN-GJN-HB555 (XCr18)	A532 Class II B	
50	Pump housing	Cast iron	EN-JL-1040	ASTM A48 Class 40B	
66	Impeller washer	Stainless steel	1.4436	316	
67	Impeller screw	Stainless steel	1.4436	316	
76	Nameplate				
150c	Outer cooling jacket	Stainless steel	1.4301	304	
494	Plug	Stainless steel	1.4436	316	

Material declaration:

- Grey cast iron is manufactured according to EN 1561:1997.
- Cast stainless steel is manufactured according to EN 10283:2010.
- Conversion to other standards such as AISI/ASTM is normative, and products are not manufactured according to these.

Accessories

Pos.	Component	Material	DIN W.-No./EN standard	AISI/ASTM
487	Horizontal base stand	Galvanized steel		
701 ⁹⁾	Auto-coupling base unit	Cast iron or stainless steel		
702	Guide-rail bracket	Cast iron or stainless steel		
703 ⁹⁾	Guide claw	Cast iron or stainless steel		
704	Rubber seal	Neoprene 60		
705	Screw	Steel 8.8	DN933	316
731	Vertical base stand	Galvanized steel		
732	Screw for base stand	Steel 8.8	DN933	316
733	Upper flange seal for base stand			
734	Lower flange seal for base stand			
749	Bend	Cast iron		
761	Hose connector	Cast iron or stainless steel		
762	Screw for hose connector	Steel 8.8	DN933	316
763	Flange seal for hose connector			

⁹⁾ Available in stainless steel (custom-built option).

7. Product description

Features

SmartTrim

All Grundfos heavy-duty S-tube® impeller pumps are equipped with the unique SmartTrim impeller clearance adjustment system. This enables easy restoration of the factory-set impeller clearance and ensures peak pumping efficiency. Only the adjustment screws on the exterior of the impeller housing need to be tightened, which can be done quickly and easily on-site, without dismantling the pump or using special tools. For a video presenting the SmartTrim assembly, click here: (<https://youtu.be/QZ6AodFNPBM>)

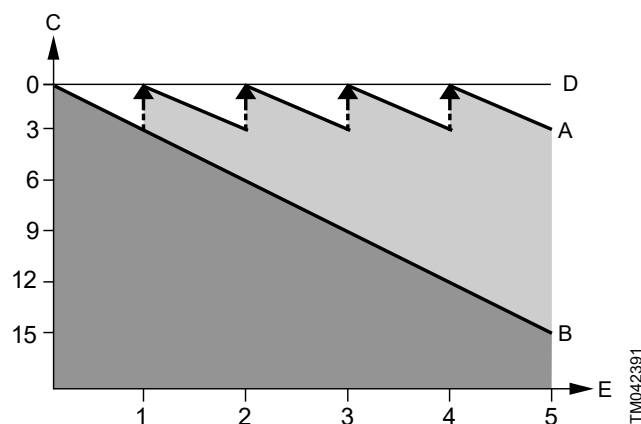

Pos.	Description
A	With Grundfos SmartTrim impeller clearance adjustment system.
B	Without impeller clearance adjustment system.
C	Efficiency drop in percent (%)
D	Factory-set impeller clearance
E	Years

SmartSeal

The Grundfos SmartSeal auto-coupling gasket mounted on the pump outlet flange provides a completely leak-proof connection between the pump and the base unit of the auto-coupling system. This optimizes the efficiency of the entire pumping system and keeps operating costs at a minimum.

Ball bearings

The bearings are greased for life.

- Main bearings: Double-row angular sealed contact ball bearing.
- Support bearing: Single-row deep-groove ball bearing.

Shaft seal



TM083097

The shaft seal consists of two mechanical seals. It separates the motor from the pumped liquid. The shaft seal is a cartridge seal for easy service. The combination of the primary and secondary seals in a cartridge results in a shorter assembly length compared to conventional shaft seals. Furthermore, this design minimizes the risk of incorrect fitting.

The seal faces of the primary shaft seal are SiC/SiC, and the seal faces of the secondary shaft seal are carbon A/ ceramic.

Motor

SE and SL 12-42 hp motor components are compatible with the IEC, IE3, and NEMA premium efficiency standards.

The motor is watertight and enclosed.

insulation class	H [356 °F]
temperature rise class	B [80 K]
enclosure class	IP68

Power cables

Standard (S1BN8-F)

Cable type [mm ²]	Outer cable diameter [in. (mm)]		Minimum bending radius [in. (mm)]
	Min.	Max.	
7 x 4 + 5 x 1.5	0.83 (21.2)	0.9 (22.8)	2.76 (70)
7 x 6 + 5 x 1.5	0.96 (24.5)	1.03 (26.1)	3.15 (80)
7 x 10 + 5 x 1.5	0.99 (25.2)	1.06 (26.8)	4.33 (110)

EMC (S1BC4N8-F)

Cable type [mm ²]	Outer cable diameter [in. (mm)]		Minimum bending radius [in. (mm)]
	Min.	Max.	
3 x 6 + 4 x 2.5 + 5 x 0.5	1.04 (26.3)	1.11 (28.3)	3.54 (90)
3 x 10 + 4 x 2.5 + 5 x 0.5	1.04 (26.3)	1.11 (28.3)	4.72 (120)
3 x 16 + 4 x 4 + 5 x 0.5	1.04 (26.3)	1.11 (28.3)	5.51 (140)

Pumps with the following voltage codes and motor power are installed with dual EMC cables:

2 pole motors

Motor power [hp]	Voltage code	
	60S (208D)	61R (230D/460Y)
Cable type [mm ²]		
30	2x (3 x 10 + 4 x 2.5 + 5 x 0.5)	-
33,5	2x (3 x 10 + 4 x 2.5 + 5 x 0.5)	2x (3 x 10 + 4 x 2.5 + 5 x 0.5)
39	2x (3 x 16 + 4 x 4 + 5 x 0.5)	2x (3 x 10 + 4 x 2.5 + 5 x 0.5)
42	2x (3 x 16 + 4 x 4 + 5 x 0.5)	2x (3 x 16 + 4 x 4 + 5 x 0.5)

4 pole motors

Motor power [hp]	Voltage code	
	60S (208D)	61R (230D/460Y)
Cable type [mm ²]		
30	2x (3 x 10 + 4 x 2.5 + 5 x 0.5)	-
33	2x (3 x 10 + 4 x 2.5 + 5 x 0.5)	2x (3 x 10 + 4 x 2.5 + 5 x 0.5)

6 pole motors

Motor power [hp]	Voltage code	
	60S (208D)	
Cable type [mm ²]		
25,5	2x (3 x 10 + 4 x 2.5 + 5 x 0.5)	

In case of a pump with EMC cable, indicate the main supply voltage as the connections for the correct voltage are inside the motor.

The standard cable length is 49 ft. Other cable lengths are available on request.

For further information see Variants of customised pumps.

The cable dimension depends on the motor size.

Surface treatment

Grundfos pumps receive the following surface treatments:

- Cathodisation treatment of all cast iron parts
- Powder painting: NCS 9000N, RAL 9005 (black), gloss code 30, thickness average 150 µm.

Motor liquid

The motor is factory-filled with Grundfos motor liquid SML-3, which is frostproof up to -4 °F.

Specification of SML-3:

- Corrosion protection
Grundfos motor liquid protects metals and alloys in the equipment against all forms of corrosion. The combination of low toxicity and FDA-approved ingredients with a high level of corrosion protection makes Grundfos motor liquid unique on the market. The anti-corrosion performance is demonstrated according to ASTM D 1384.
- Compatibility and miscibility
Grundfos motor liquid is compatible with most other heat transfer fluids based on mono-propylene glycol.

- Toxicity and safety

Grundfos motor liquid consists of FDA-approved components for heat transfer fluids with incidental food contact. Grundfos motor liquid is classified according to the European Dangerous Preparations Directive.

Cable entry

The watertight, stainless-steel cable entry has soft shape and sealing rings to prevent cable damage or leaks. The cable entry has a user-friendly design, which allows fast and easy cable disconnection.

Sensors

SE/SL pumps are available with built-in sensors.

Built-in sensors reduce the risk of downtime and severe damage to the pump.

Sensors can be used for different purposes depending on pump type and connection. For instance, moisture, leakage or level switches cut out power in case of water leaking through the cable entry, cable or shaft seal. Bearing temperature sensors are used for monitoring the temperatures in the bearings.

Built-in sensors:

- three thermal switches, one in each phase
- one moisture switch below the motor top cover
- one level switch in the leakage chamber for standard pumps
- one leakage switch in the stator housing for Ex pumps

Sensor version 1 pump sensors:

- all built-in sensors
- Pt1000 sensor in the stator winding for temperature measurement.

Sensor version 2 pump sensors:

- Pt1000 sensor in the stator winding for temperature measurement
- Pt1000 sensor in the upper and lower bearing for temperature measurement
- SM 113 sensor module.

Switch and sensor specifications

	Standard pump	Sensor version 1	Sensor version 2	Standard Ex	Sensor version 1 Ex	Sensor version 2 Ex
Thermal switches or PTC	•	•	•	•	•	•
Moisture switch	•	•	•			
Level switch in leakage chamber for standard motors	•	•	•			
Leakage switch in stator housing for Ex motors				•	•	•
Pt1000 in stator winding		•	•		•	•
Pt1000 in upper bearing				•		•
Pt1000 in lower bearing				•		•
PVS3 vibration sensor				•		•
SM 113 module ¹⁰⁾				•		•
IO 113 module ¹¹⁾				•		•

¹⁰⁾ For pumps fitted with two power supply cables, the SM 113 module must be ordered separately and installed in the control cabinet. SM113 needs to be fitted with a resistor.

¹¹⁾ The IO 113 with communication functionality has to be chosen and ordered separately.



Ex pumps manufactured from 1st of March 2025 will be installed with a leakage switch instead of a level switch. This Data Booklet only contains wiring diagrams for pumps with a leakage switch. The Installation and Operating Instructions contains wiring diagrams for pumps with a level switch, and pumps with a leakage switch.

IO 113 module with communication functionality



The IO 113 with communication functionality is a protection module for Grundfos wastewater pumps.

It has inputs for digital and analog pump sensors and can stop the pump if a sensor indicates a fault.

If the IO 113 with communication functionality is connected to the Dedicated Controls (DC) system, it allows the following advanced monitoring functions:

- motor temperature
- moisture in motor

- insulation resistance.

SM 113 sensor module



GR-1014621

The SM 113 sensor module is used for collecting and transferring sensor data. The SM 113 sensor module works together with the IO 113 through power line communication using the Grundfos GENIbus protocol.

The SM 113 sensor module collects data from:

- 3 current sensors, 4-20 mA
- 3 Pt1000 thermal sensors
- 1 PTC thermal sensor
- 1 digital input.

PVS 3 (pump vibration sensor)

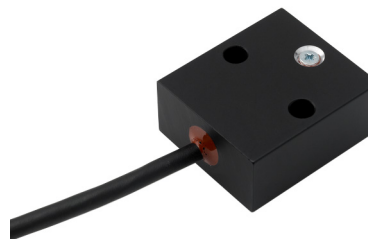

TM077106

The pump vibration sensor monitors the vibration level of the pump in three axes. Change in the vibration level indicates an irregular situation, which can be caused by a clogged impeller, worn bearings or a closed outlet valve. Carry out a service inspection to protect the pump and the pipe system from damage.

MP 204



GR-1015249

The MP 204 can be used as a stand-alone motor protector or it can be incorporated in a Grundfos Dedicated Controls system, where it functions as a motor protector. The pump is protected secondarily by measuring the temperature with a Pt100 sensor and a PTC sensor or thermal switch.

Customized sensor options

1. Each motor winding has three built-in thermistors (PTC), which can be used instead of the normal thermal switches (PTO). If used, a relay is needed to disconnect power in case of excess temperature.
2. The stator temperature sensor is an analogue sensor. Especially for versions without a cooling jacket, a temperature sensor in the stator can be used to give a warning before the stator/ bearings or other parts would reach a harmful temperature and the built-in thermal protection cuts-out the motor on overtemperature. In this way, the pump operates with the stator housing above liquid level, for short periods and with long intervals.
3. The upper and lower bearing temperature are monitored by Pt1000 type sensors.
4. The vibration level of the pump is monitored by a Grundfos PVS3 sensor (4 20 mA analogue sensor). A change in the vibration level indicates an abnormal situation. This can be caused by a clogged impeller, worn bearings or a closed outlet valve. It indicates that service inspection must be carried out to protect the pump or the pipe system from being damaged.
5. The winding resistance can be measured with/through the Grundfos IO 113 module with communication functionality.

Testing

Pumps are tested before leaving the factory. The factory test report is based on centrifugal pump test ANSI-HI 11.6:2022, acceptance level 3B. Test reports can be ordered directly together with the pump or separately with the pump serial number.

Operating conditions

SL, SL1, SL2 and SLV pumps without cooling jacket, submerged installation

- Continuous operation: The pump is completely submerged to the top of the motor.
- Intermittent operation: The pump is submerged to the middle of the motor and with short periods of operation down to the top of the pump housing (maximum 20 starts per hour).

Note: Explosion-proof pumps must always be completely submerged.

SL pump installation types

Grundfos SL pumps can permanently be installed vertically and submerged on an auto-coupling system.

SE, SE1, SE2 and SEV pumps with cooling jacket, submerged or dry installation

- Both continuous and intermittent operation are allowed.

SE pump installation types

Grundfos SE pumps can be installed:

- permanently vertically and submerged on an auto-coupling system
- vertically and dry, on a vertical base stand, or on a concrete foundation with base plate, according to Standard ANSI/HI 1.4
- horizontally and dry, on a horizontal base stand.

Frequency converter, CUE



TM084173

Grundfos SE and SL pumps are designed for speed-controlled operation to keep the energy consumption at a minimum.

To avoid the risk of sedimentation in the pipes, operate the speed-controlled pump within a speed range of 30 to 100 % and at a flow rate above 3.3 ft/s.

A frequency converter that is connected to a wastewater pump must be able to deliver a high and constant start torque.

Grundfos offers a range of dedicated Grundfos CUE frequency converters up to 340 hp designed to run wastewater pumps.

A frequency converter offering the possibility to run the wastewater pump in reverse operation is preferable.

For more information, see the installation and operating instructions for the selected frequency converter at www.grundfos.com (Grundfos Product Center).

Pumped liquids

- pH value: 6.5 - 14
- Fluctuating pH values: pH 4 - 14.
- Liquid temperature: 32 - 104 °F.

When pumping liquids with a density and/or a kinematic viscosity higher than water, use motors with correspondingly higher outputs.

For short periods (maximum 3 minutes), a temperature of up to 140 °F is permissible (non-Ex versions only).

Sound pressure

The sound pressure level, in some cases, may exceed 70dB.

Motor range

Shaft power [hp]	Number of poles
11	6
12	4
13.5	6
15	4
16	6
17.5	2, 4
19	6
20	2, 4
21.5	6
23	2
24	4
25	2
25.5	6
27	4
29	2, 4, 6
33	4
34	2
36	2
39	2
42	2

Approvals (cFMus)

The standard pumps are approved by FM Approvals. The explosion-proof versions have the following Certificates of Conformity:

- FM16US0410X¹²⁾
- FM16CA0187X¹²⁾

¹²⁾ The letter X in the certificate number indicates that the equipment is subject to special conditions for safe use. The conditions are described in the certificate and the installation and operating instructions.

Approval standards

The pumps are approved by FM Approvals according to CSA C22.2 No. 60079-0, CSA C22.2 No. 60079-1, CSA C22.2 No. 0.4, CSA C22.2 No. 100, CSA C22.2 No. 145, CSA C22.2 No. 157, and CSA C22.2 No. 60529, CSA C22.2 No. 60079-11, and FM 3600, FM3610, FM 3615, FM 3650, and ANSI/IEC 60529, ANSI/UL 60079-0, ANSI/UL 60079-1, ANSI/UL 60079-11.

Explanation of FM approval

The pumps have the following explosion-protection classification with an ambient temperature rating of -4 to 104 °F (-20 to +40 °C):

Standards	Code	Description
FM 3600	XP	Explosion Proof type of protection
FM 3610	Class I	Explosive atmosphere caused by gas or vapors
FM 3615		
FM 3650	Division 1	Area classification
ANSI/IEC 60529	Groups C and D	Classification of gases
CSA C22.2 No. 0.4		
CSA C22.2 No. 100	T4/T3 ¹³⁾	Maximum surface temperature is 275 °F (135 °C) and 392 °F (200 °C)
CSA C22.2 No. 145		
CSA C22.2 No. 157	IP68	Enclosure class according to IEC 60529
	Ex	Marking of explosion protection
	db	Flame-proof enclosure
CSA C22.2 No. 60079-0	IIB	Classification of gases, gas group B includes gas group A.
CSA C22.2 No. 60079-1		
CSA C22.2 No. 60079-11	T4, T3 ¹³⁾	maximum surface temperature of the motor is 392 °F (200 °C).
ANSI/UL 60079-0		
ANSI/UL 60079-1		
ANSI/UL 60079-11	Gb	Equipment for explosive gas with "high" level of protection.

¹³⁾ When operated by a frequency converter.

Level controllers

Grundfos offers dedicated pump controllers for monitoring liquid levels in the wastewater collecting tanks to ensure correct operation and protection of the pumps.

The following pump controllers are available:

- Grundfos Dedicated Controls (DC)
- Grundfos LC controllers.

Grundfos DC Controllers



TM084174

Grundfos Dedicated Controls control cabinet

Grundfos Dedicated Controls (DC) is a control system designed for installation in municipal wastewater transportation, commercial buildings or network pumping stations with up to six wastewater pumps and an optional mixer or a flush valve.

Advanced control and data communication are also possible with the Grundfos DC system. The control cabinets are delivered with a built-in main switch and thermal-magnetic circuit breaker.

Features and benefits:

- Advanced Flow Calculation
- automatic energy optimization
- easy installation and configuration
- configuration wizard
- electrical overview
- advanced data communication
- advanced alarm and warning priority
- supports several languages

- daily emptying
- mixer control or flush valve
- user-defined functions
- anti-blocking
- start level variation
- advanced pump alternation with pump groups
- SMS scheduling
- communication to SCADA, BMS, GRM or cell phone.

Dedicated Controls is ordered either with or without a built-in communication interface module (CIM).

The communication module enables the possibility for fieldbus protocol (PROFIBUS DP, Modbus RTU and PROFINET IO/Modbus TCP) and the communication line.

For further information about Grundfos Dedicated Controls, see Grundfos Product Center:

- Grundfos Dedicated Controls, brochure <http://net.grundfos.com/qr/i/96925597>
- Grundfos iSolutions, brochure (L-IND-SL-05) <http://net.grundfos.com/qr/i/99249771>
- Grundfos Controls Guide, product guide <http://net.grundfos.com/qr/i/97954965>
- Grundfos Dedicated Controls, data booklet <http://net.grundfos.com/qr/i/98672840>.

Additional features, CUE or VFD

Grundfos variable frequency drive CUE or a general variable frequency drive (VFD) offers better pump protection and a more steady flow through the pipe system.

In addition, Grundfos CUE or variable frequency drive VFD offers the following features and benefits:

- anti-blocking
- automatic energy optimization
- specific-energy test
- output frequency
- monitoring of:
 - voltage*
 - current*
 - phase sequence*
 - power*
 - energy*
 - torque*
- reverse start**
- run flushing
- stop flushing
- PID control.

*These functions are only available with a Grundfos CUE.

** Reversing at full speed is not recommended. When reduced reverse operation settings are set, make sure constant torque is enabled in VFD (Grundfos CUE, Siemens Simatic, ABB, Schneider Electric etc.) to have maximum torque available when reversing.

Grundfos LC controllers

The LC 231 pump controller is designed for level control, monitoring and protection of Grundfos pumping stations featuring one or two pumps, starting direct-on-line. The LC 231 controller is built into a polymer cabinet.

The LC 241 is a modular pump controller that has a metal or polymer cabinet and can be customised.

The LC 231 and 241 controllers are designed for level control, monitoring and protection of Grundfos pumping stations featuring one or two pumps, starting direct-on-line with 0-23 A, star-delta with 0-59 A or soft starter with 0-72 A.



TM074000

LC 231 and LC 241 controller units

Wiring diagrams

Cable connection

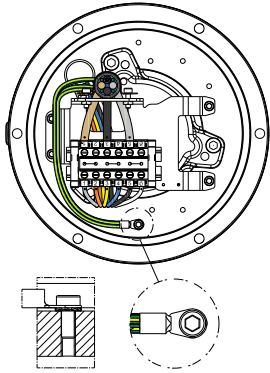

Earthing screw, single cable, EMC

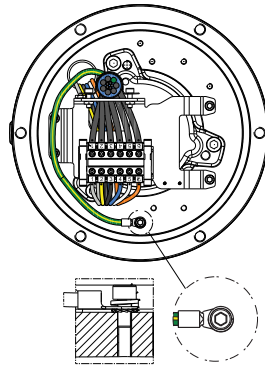

Earthing screw, standard

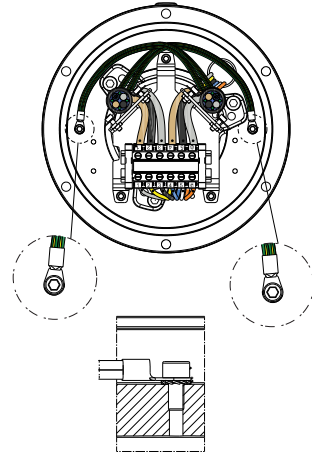

Earthing screw, dual cable EMC

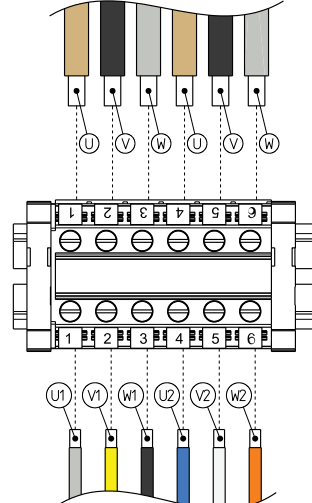
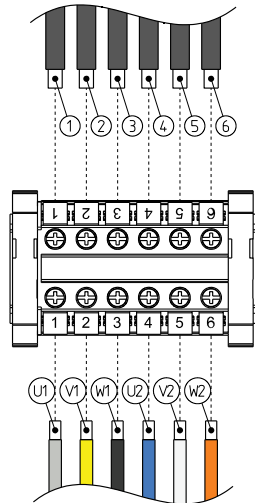
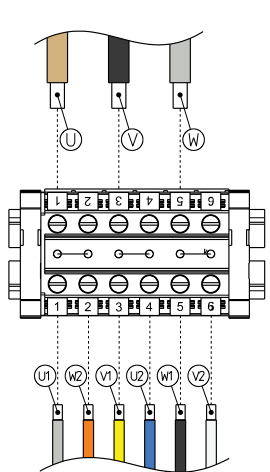

Single cable, star-delta connection

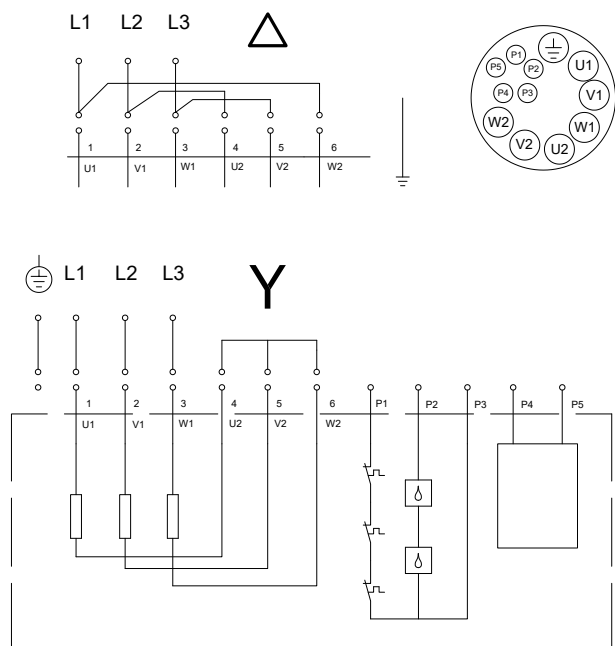

12-wire, star-delta connections (Y/D): D: connections for 3 x 460 V (1G), 3 x 208 V (0S) or 3 x 230 V (1R) Y: connections for 3 x 460 V (1R)

Position	Description
P1, P3	PTC/PTO circuit
P2, P3	Moisture / leakage / level switch circuit
P4, P5	Pt1000 circuit for sensor version 1, or SM113 circuit for sensor version 2

Electromagnetic cable (EMC) single cable



Main supply voltage must be stated since the pump will be connected according to this from factory.

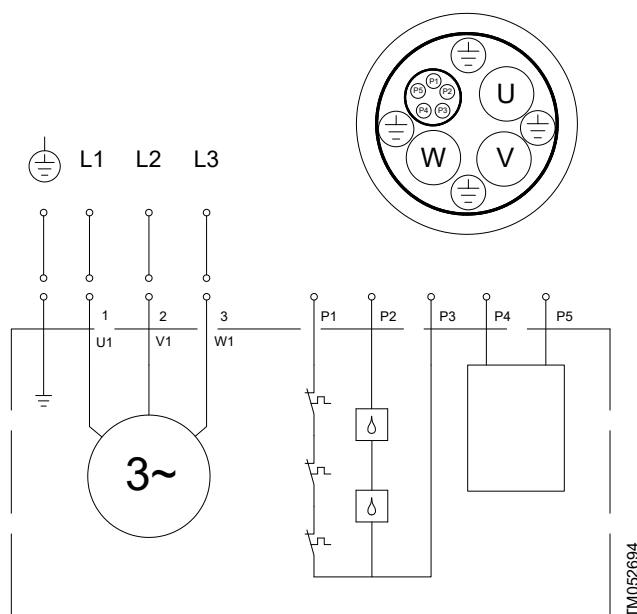

8-wire, EMC cable

Position	Description
P1, P3	PTC/PTO circuit
P2, P3	Moisture / leakage / level switch circuit
P4, P5	Pt1000 circuit for sensor version 1, or SM113 circuit for sensor version 2

Electromagnetic cable (EMC) double-cable

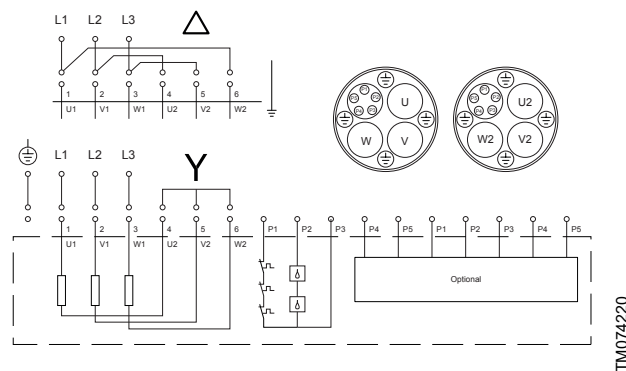

18-wire / EMC double cable

Position	Description
P1, P3	PTC/PTO circuit
P2, P3	Moisture / leakage / level switch circuit
Optional	Pt1000 circuit for sensor version 1, or SM113 circuit for sensor version 2

Sensor wiring

Sensor wiring schematics for single cable pumps

Standard, single cable

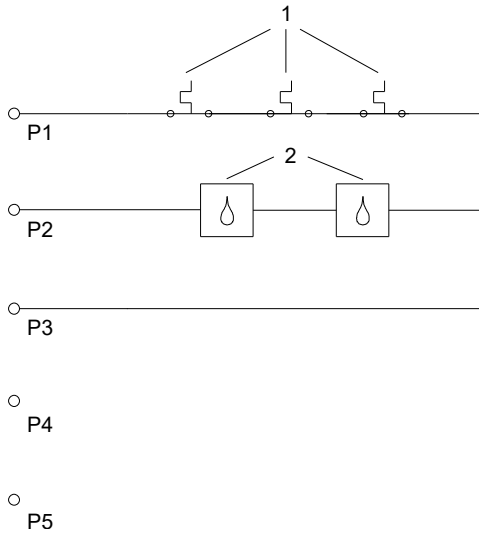

TM088893

Standard and Standard Ex, single cable

Pos.	Description
1	Thermal switches / Thermistor
2	Moisture/Leakage/Level switch

Sensor version 1, single cable

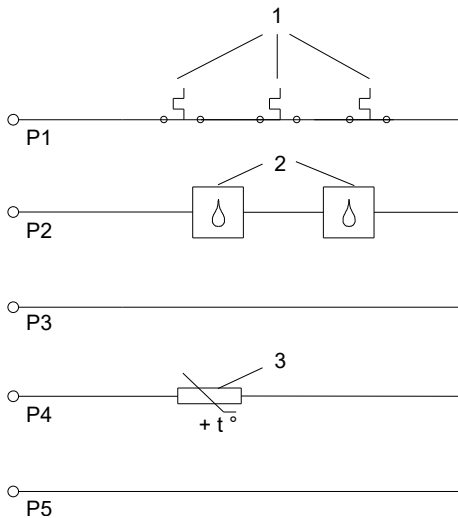

TM088894

Sensor version 1 and Sensor version 1 Ex, single cable

Pos.	Description
1	Thermal switches / Thermistor
2	Moisture/Leakage/Level switch
3	Pt1000

Sensor version 2, single cable

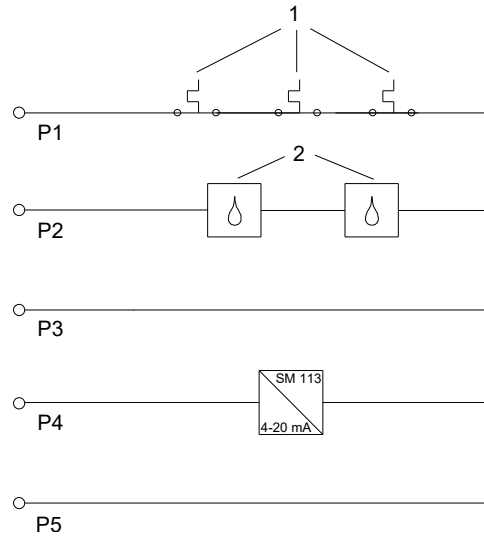

TM088895

Sensor version 2 and Sensor version 2 Ex, single cable

Pos.	Description
1	Thermal switches / Thermistor
2	Moisture/Leakage/Level switch

Sensor version 2 Ex PTC single-cable

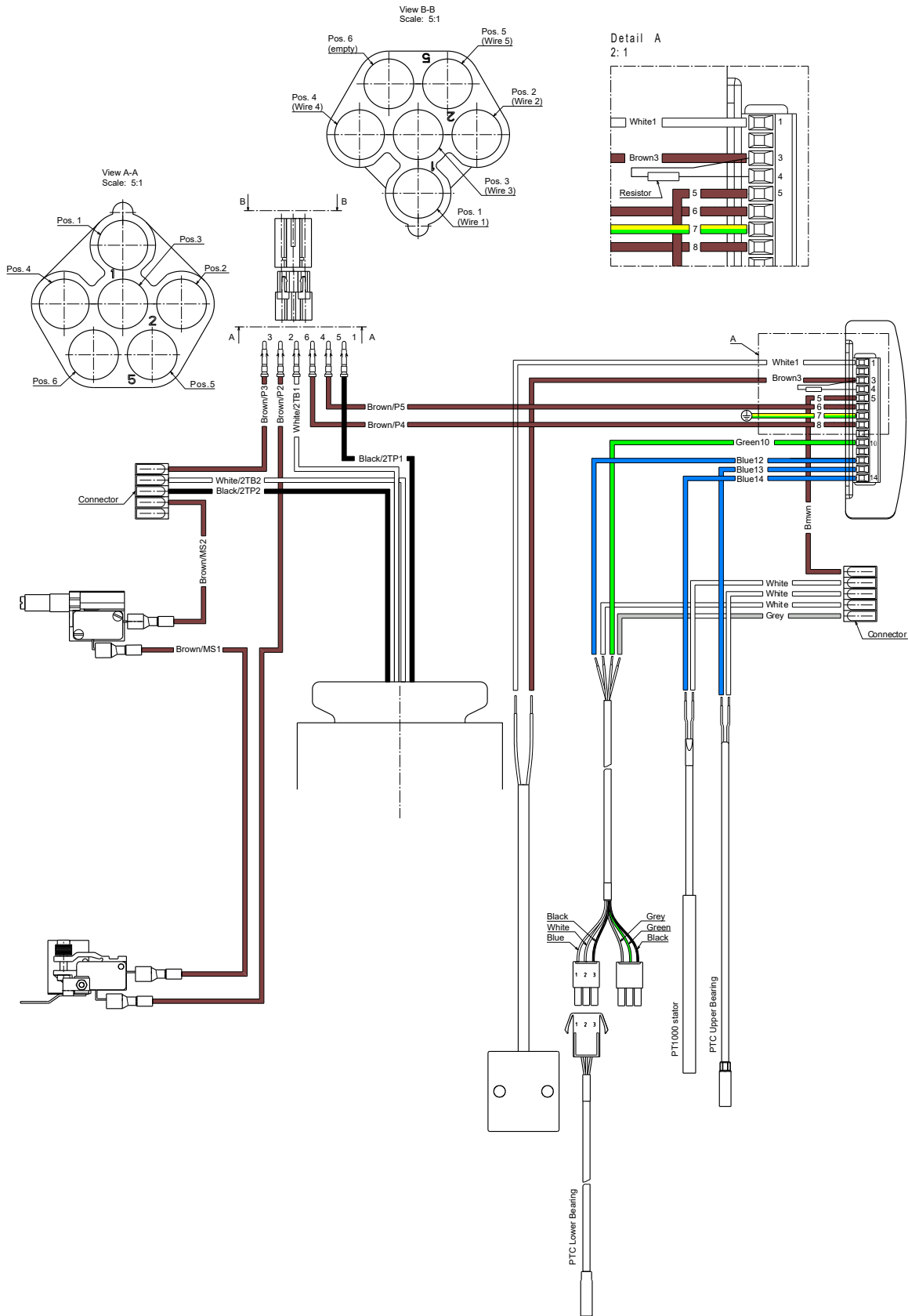

Sensor wiring schematics for double cable pumps

Standard, double cable

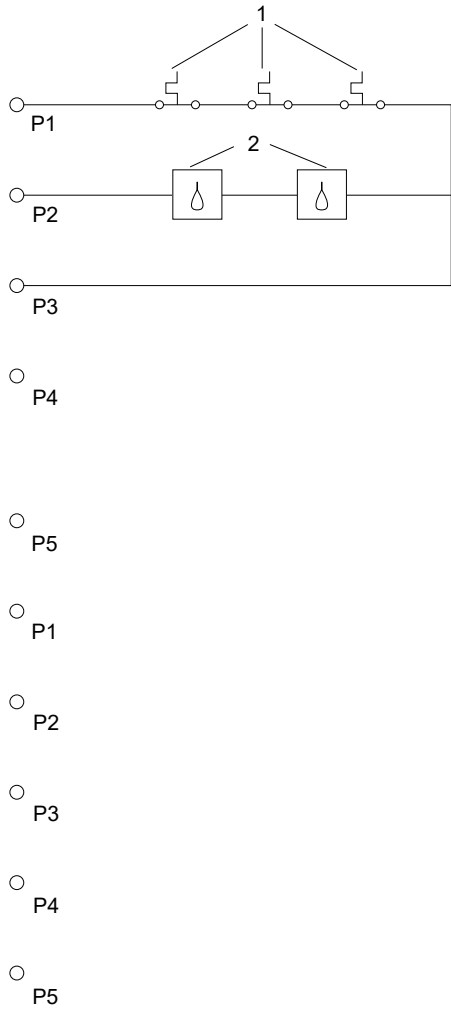

TM088896

Standard and Standard Ex, double cable

Pos.	Description
1	Thermal switches / Thermistor
2	Moisture/Leakage/Level switch

Sensor 1, double cable

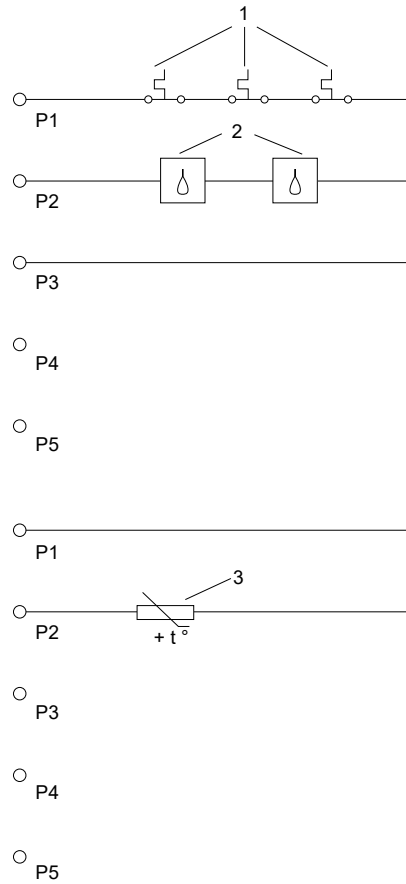

TM088898

Sensor 1 and Sensor 1 Ex, double cable

Pos.	Description
1	Thermal switches / Thermistor
2	Moisture/Leakage/Level switch
3	Pt1000 stator

Sensor 2, double cable

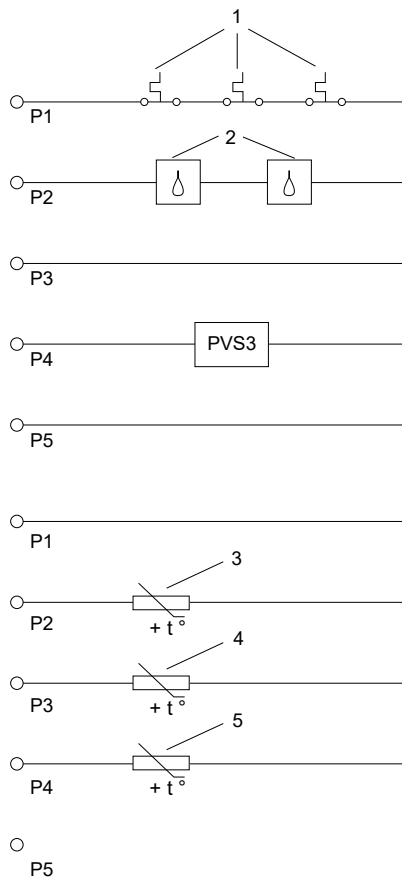

Sensor 2 and Sensor 2 Ex, double cable

Pos.	Description
1	Thermal switches / Thermistor
2	Moisture/Leakage/Level switch
PVS3	Vibration sensor
3	Pt1000 stator
4	Pt1000 upper bearing
5	Pt1000 lower bearing

TM088897

Sensor version 2 Ex PTC double-cable

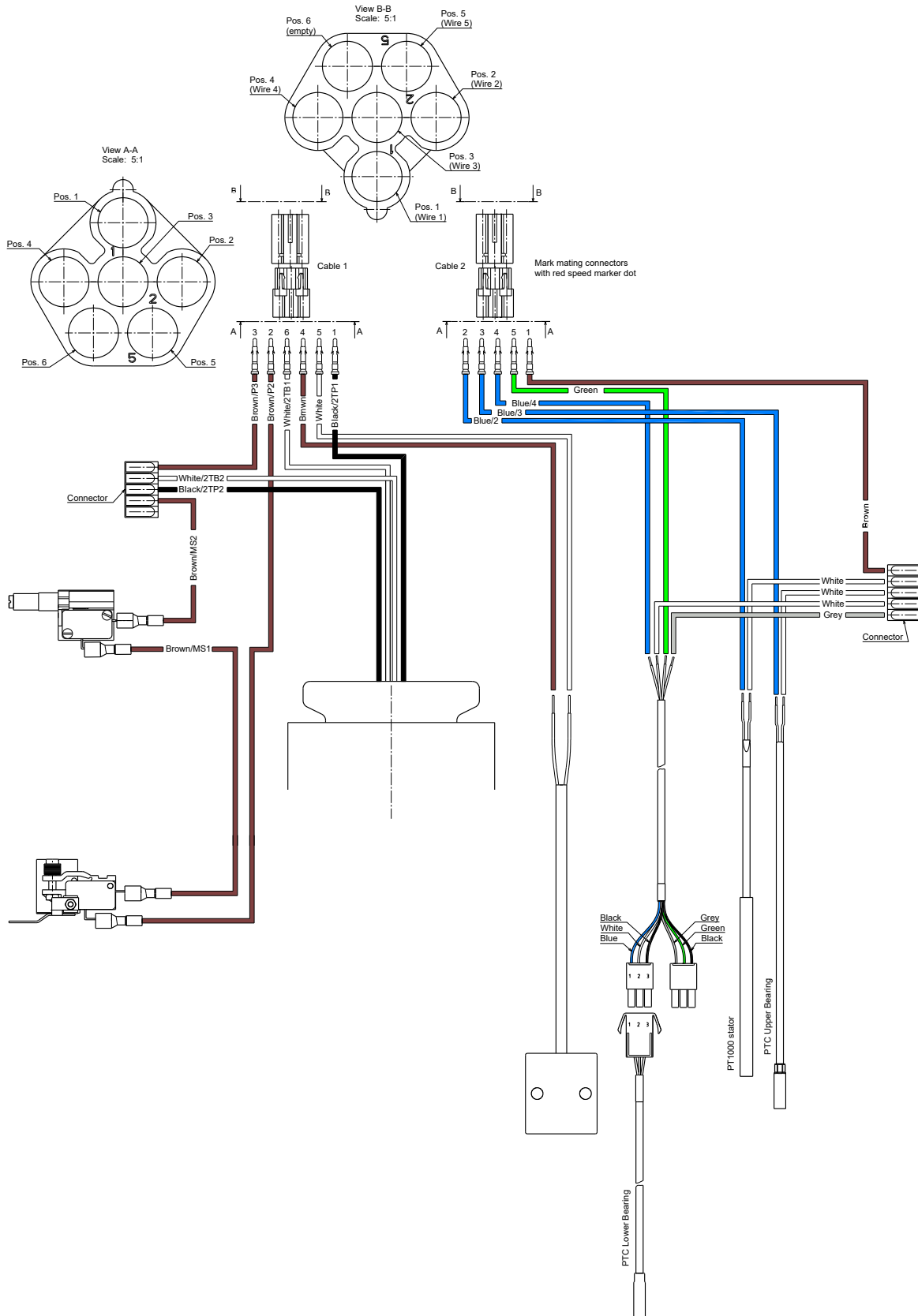

TM088937

Switch and sensor positions - Level or Leakage Switch

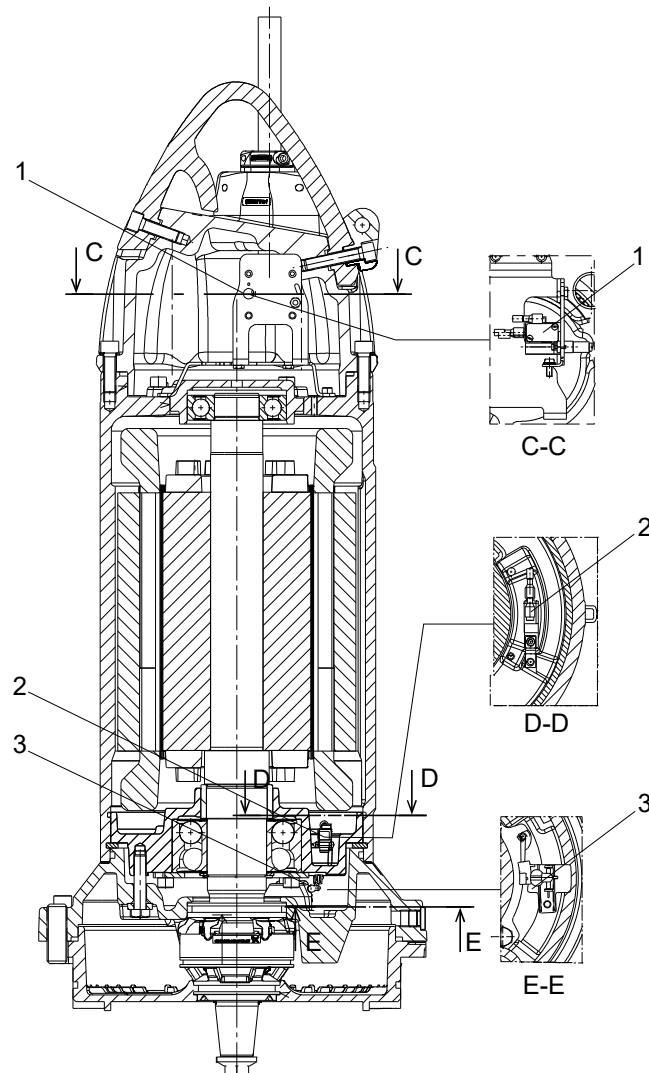

TM087800

Pumps installed with leakage or level switch

Pos.	View	Description
1	C-C	Moisture switch
2	D-D	Leakage switch in stator housing, for Ex motors
3	E-E	Level switch in leakage chamber for standard motors

8. Performance curves and technical data

How to read the performance curves

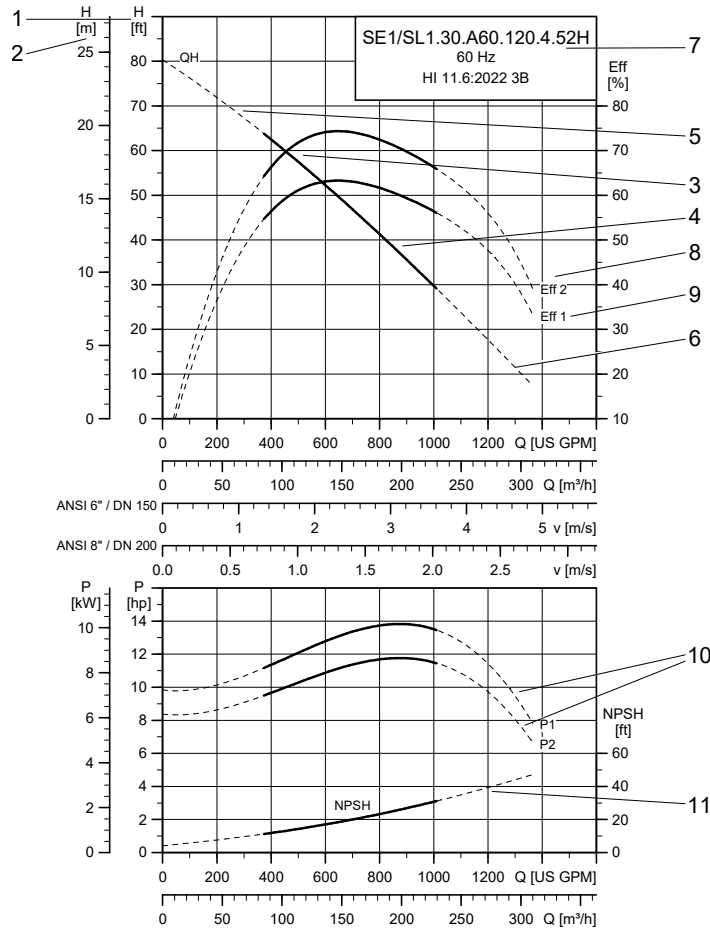

TM079083

Pos.	Description
1	Total pump head
2	$H = H_{total}$
3	QH curve
4	The solid line represents the allowed operating range.
5	The dotted line represents the range within which the pump is not designed to operate.
6	The pump should not operate outside the solid line or against a closed valve (shut-off valve).
7	Pump type
8	Eff2: the hydraulic efficiency (pump)
9	Eff1: the total efficiency (pump + motor)
10	Power curve indicates input power [P ₁] and output power [P ₂] of the pump.
11	The shown NPSH curve for all variants is defined as maximum NPSH curves according to ANSI/HI 11.6:2022 3B.

Note: Pumps are tested according to ANSI/HI 11.6:2022, 3B tolerances. Testing equipment and measuring instruments are designed and calibrated according to the standards mentioned. The pumps are approved according to the tolerances for the entire curve, specified in grade 3B.

Curve conditions

The guidelines below apply to the curves indicated in the performance curves section.

- Tolerances according to: ANSI/HI 11.6:2022, 3B.
- The curves show pump performance with different impeller diameters at rated speed.
- The curves apply to the pumping of airless water at a temperature of 68 °F and a kinematic viscosity of 1 mm²/s (1 cSt).
- **ETA:** The lines show the hydraulic efficiency values of the pump for different impeller diameters.
- **NPSH:** The curves show maximum NPSH values according to ANSI/HI 11.6:2022, 3B.
- In case of densities other than 133.5 ounces/gallon, the outlet pressure is proportional to the density.
- When pumping liquids with a density higher than 133.5 ounces/gallon (1000 kg/m³), use motors with correspondingly higher outputs.

Calculation of total head

The total pump head consists of the height difference between the measuring points, the differential head and the dynamic head.

H_{total}	=	$H_{geo} + H_{stat} + H_{dyn}$
H_{geo} :		height difference between measuring points
H_{stat} :		differential head between the inlet and the outlet side of the pump
H_{dyn} :		calculated values based on the velocity of the pumped liquid on the inlet and the outlet side of the pump

Performance tests

All the pumps are factory tested to a Grundfos testing standard that is similar to the Hydraulic Institute ANSI/HI 11.6:2022, grade 3B. These Grundfos standard curves are provided with each pump.

The testing equipment and measuring instruments are designed and calibrated in accordance with the mentioned standards.

For customized duty point or other grades with a 5-point test certificate, contact Grundfos.

Certificates

Certificates are available on request and have to be confirmed for each order.

Witness test

According to ANSI/HI 11.6:2022, 3B, the customer can witness the testing procedure.

The witness test is not a certificate and will not result in a written statement from Grundfos. The witness test itself is the only guarantee that everything is carried out as prescribed in the testing procedure.

If a witness test is required, the request must be stated on the order.

SuperVortex impeller

SEV/SLV.30.A30.175.2.52H

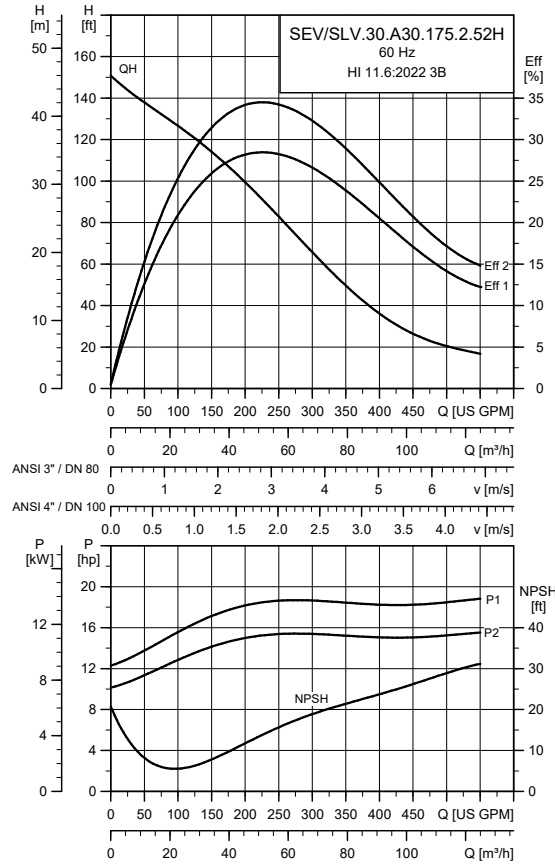

TM062268

Note: Performance grade 3B is the minimum standard to which any pump is tested before shipping from the factory. See, [Variants of customized pumps - Tests](#), for testing options. See, [How to read the performance curves](#).

Electrical data

Pump type	Voltage variant	P1 [hp (kW)]	P2 [hp (kW)]	Number of poles	RPM	Starting method	I _N			I _{start}			η _{motor} [%]			Cos φ			Moment of inertia [lbf·ft ² (kgm ²)]	Breakdown torque M _{max} [lbf·ft (Nm)]
							[A]	[A]	[A]	1/2	3/4	1/1	1/2	3/4	1/1	1/2	3/4	1/1		
SEV/ SLV.30.A30.175.2.52H	60S 3 x 208 V	20.5 (15)	17.4 (13)	2	3569	D	51	270	78	82	85	0.73	0.80	0.85	1.16	(0.0490)	59	(80)		
	61R 3 x 230/460 V	20.5 (15)	17.4 (13)	2	3569	Y/D	46/ 23	308/ 213	78	82	85	0.73	0.80	0.85	1.16	(0.0490)	74	(100)		
	61M 3 x 575-600 V	20.5 (15)	17.4 (13)	2	3569	D	19-18	155	78	82	85	0.73	0.80	0.85	1.16	(0.0490)	99	(134)		

Pump data

Pump type	Impeller diameter	Max. solids size	Outlet flange pressure (according to ASME B 16.5)	Max. installation depth
	[in. (mm)]	[in. (mm)]	[PSI (PN)]	[ft (m)]
SEV/SLV.30.A30.175.2.52H	7.4 (189)	3.0 (80)	145 (10)	66 (20)

Note: Pumps with stainless steel SuperVortex impellers have the same performance curves as the corresponding cast iron versions.

SEV/SLV.30.A30.200.2.52H

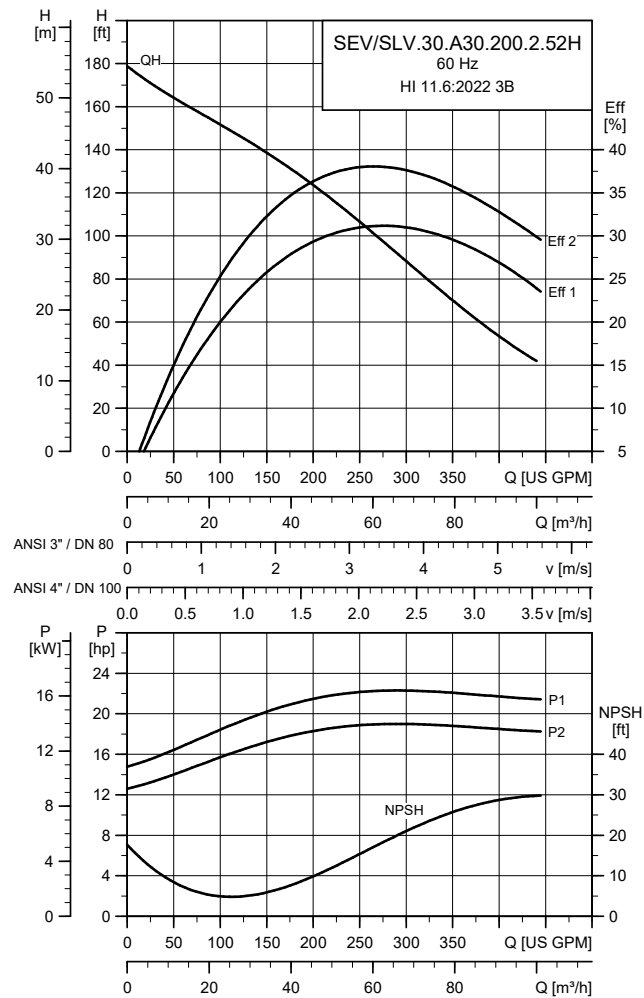

TM062269

Note: Performance grade 3B is the minimum standard to which any pump is tested before shipping from the factory. See, [Variants of customized pumps - Tests](#), for testing options. See, [How to read the performance curves](#).

Electrical data

Pump type	Voltage variant	P1	P2	Number of poles	RPM	Starting method	I_N			η_{motor} [%]			Cos ϕ			Moment of inertia [lbft ² (kgm ²)]	Breakdown torque M_{max} [lbft ² (Nm)]
		[hp (kW)]	[hp (kW)]				[A]	[A]	1/2	3/4	1/1	1/2	3/4	1/1			
SEV/ SLV.30.A30.200.2.52H	60S 3 x 208 V	23.5 (18)	20.1 (15)	2	3564	D	57	270	80	84	86	0.75	0.83	0.86	1.16 (0.0490)	59 (80)	
	61R 3 x 230/460 V	23.5 (18)	20.1 (15)	2	3564	Y/D	51/26	308/213	80	84	86	0.75	0.83	0.86	1.16 (0.0490)	74 (100)	
	61M 3 x 575-600 V	23.5 (18)	20.1 (15)	2	3564	D	21-20	155	80	84	86	0.75	0.83	0.86	1.16 (0.0490)	99 (134)	

Pump data

Pump type	Impeller diameter	Max. solids size	Outlet flange pressure (according to ASME B 16.5)	Max. installation depth
	[in. (mm)]	[in. (mm)]	[PSI (PN)]	[ft (m)]
SEV/SLV.30.A30.200.2.52H	7.8 (199)	3.0 (80)	145 (10)	66 (20)

Note: Pumps with stainless steel SuperVortex impellers have the same performance curves as the corresponding cast iron versions.

SEV/SLV.30.A30.230.2.52H

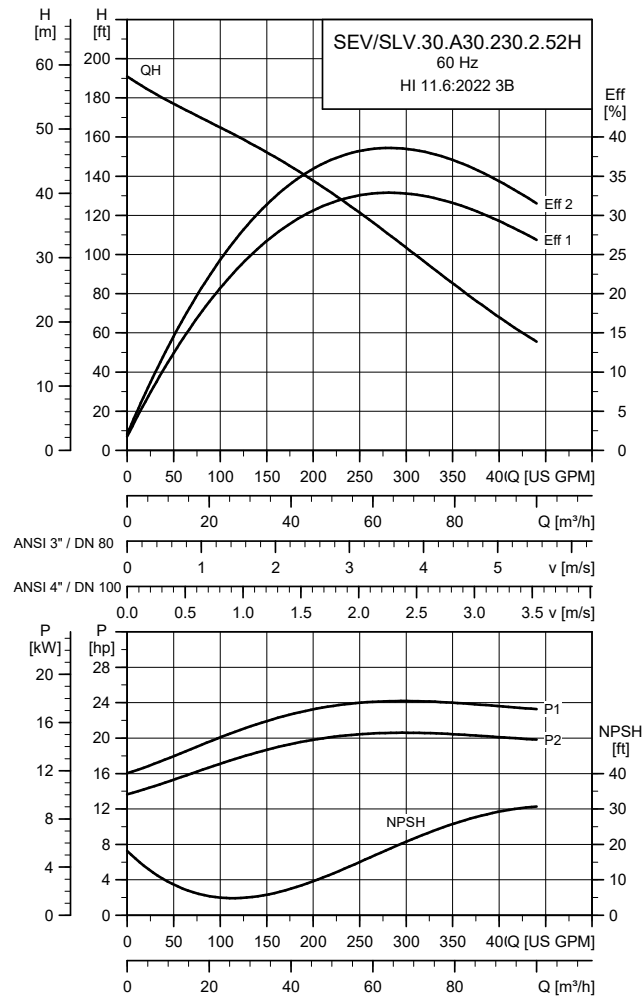

TM062270

Note: Performance grade 3B is the minimum standard to which any pump is tested before shipping from the factory. See, [Variants of customized pumps - Tests](#), for testing options. See, [How to read the performance curves](#).

Electrical data

Pump type	Voltage variant	P1	P2	Number of poles	RPM	Starting method	I _N [A]	I _{start} [A]	η _{motor} [%]			Cos φ			Moment of inertia [lbft ² (kgm ²)]	Breakdown torque M _{max} [lb*ft (Nm)]
		[hp (kW)]	[hp (kW)]						1/2	3/4	1/1	1/2	3/4	1/1		
SEV/ SLV.30.A30.230.2.52H	60S 3 x 208 V	26.2 (20)	22.8 (17)	2	3567	D	63	477	82	85	87	0.73	0.82	0.86	1.38 (0.0580)	137 (186)
	61R 3 x 230/460 V	26.2 (20)	22.8 (17)	2	3567	Y/D	57/29	373/258	82	85	87	0.73	0.82	0.86	1.38 (0.0580)	104 (141)
	61M 3 x 575-600 V	26.2 (20)	22.8 (17)	2	3567	D	23-22	207	82	85	87	0.75	0.84	0.88	1.38 (0.0580)	130 (176)

Pump data

Pump type	Impeller diameter	Max. solids size	Outlet flange pressure (according to ASME B 16.5)	Max. installation depth
	[in. (mm)]	[in. (mm)]	[PSI (PN)]	[ft (m)]
SEV/SLV.30.A30.230.2.52H	8.0 (204)	3.0 (80)	145 (10)	66 (20)

Note: Pumps with stainless steel SuperVortex impellers have the same performance curves as the corresponding cast iron versions.

SEV/SLV.30.A30.250.2.52H

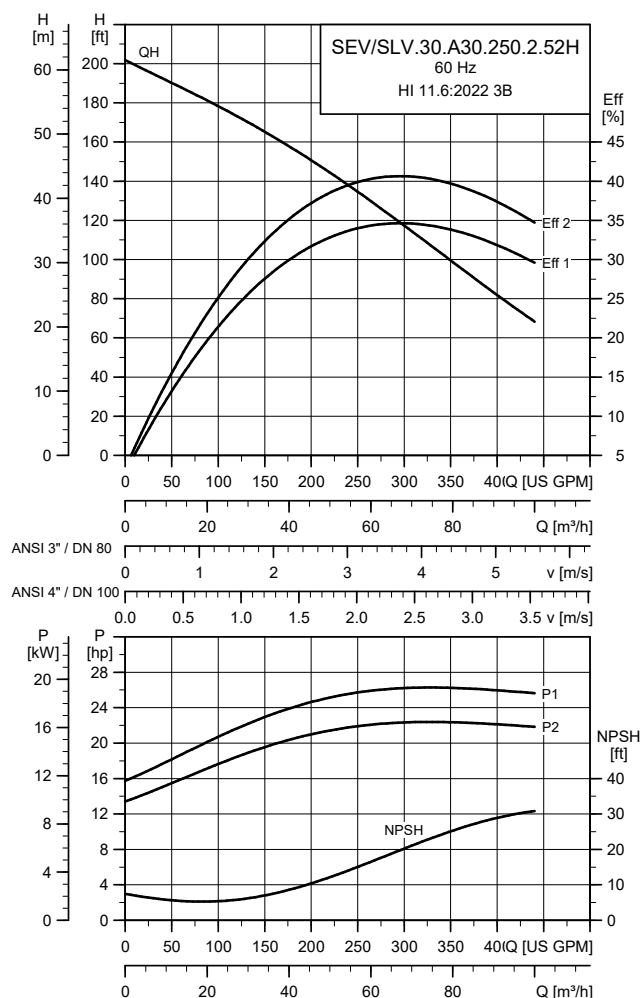

TM062271

Note: Performance grade 3B is the minimum standard to which any pump is tested before shipping from the factory. See, [Variants of customized pumps - Tests](#), for testing options. See, [How to read the performance curves](#).

Electrical data

Pump type	Voltage variant	P1	P2	Number of poles	RPM	Starting method	I_N			$\eta_{\text{motor}} [\%]$			$\text{Cos } \varphi$			Moment of inertia [lbft ² (kgm ²)]	Breakdown torque M_{max} [lbft ² (Nm)]
		[hp (kW)]	[hp (kW)]				[A]	[A]	1/2	3/4	1/1	1/2	3/4	1/1			
SEV/ SLV.30.A30.250.2.52H	60S 3 x 208 V	28.4 (21)	24.8 (18.5)	2	3565	D	69	477	83	86	87	0.75	0.84	0.86	1.38 (0.0580)	137 (186)	
	61R 3 x 230/460 V	28.4 (21)	24.8 (18.5)	2	3565	Y/D	62/31	373/ 258	83	86	87	0.75	0.84	0.86	1.38 (0.0580)	104 (141)	
	61M 3 x 575-600 V	28.4 (21)	24.8 (18.5)	2	3565	D	25-24	207	83	86	87	0.77	0.86	0.88	1.38 (0.0580)	130 (176)	

Pump data

Pump type	Impeller diameter	Max. solids size	Outlet flange pressure (according to ASME B 16.5)	Max. installation depth
	[in. (mm)]	[in. (mm)]	[PSI (PN)]	[ft (m)]
SEV/SLV.30.A30.250.2.52H	8.3 (210)	3.0 (80)	145 (10)	66 (20)

Note: Pumps with stainless steel SuperVortex impellers have the same performance curves as the corresponding cast iron versions.

SLV/SEV.30.A30.300.2.52H

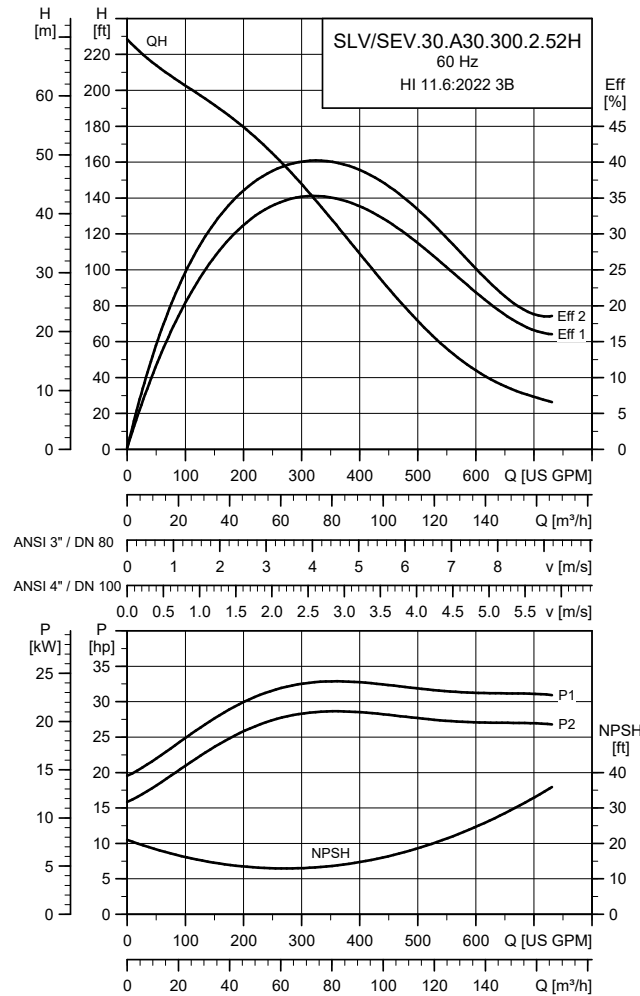

TM054120

Note: Performance grade 3B is the minimum standard to which any pump is tested before shipping from the factory. See, [Variants of customized pumps - Tests](#), for testing options. See, [How to read the performance curves](#).

Electrical data

Pump type	Voltage variant	P1	P2	Number of poles	RPM	Starting method	I _N		η _{motor} [%]			Cos φ			Moment of inertia [lbf ² (kgm ²)]	Breakdown torque M _{max} [lbf ² ft (Nm)]
		[hp (kW)]	[hp (kW)]				[A]	[A]	1/2	3/4	1/1	1/2	3/4	1/1		
SLV/ SEV.30.A30.300.2.52H	60R 3 x 230 V	33.2 (25)	29.5 (22)	2	3551	D	75	723	85	87	89	0.62	0.75	0.84	1.54 (0.0650)	181 (245)
	61G 3 x 380-480/660-690 V	33.2 (25)	29.5 (22)	2	3551	Y/D	50-39/29-28	572/262	85	87	89	0.55	0.68	0.77	1.54 (0.0650)	171 (232)
	61M 3 x 575-600 V	33.2 (25)	29.5 (22)	2	3551	D	31-30	405	85	87	89	0.59	0.72	0.81	1.54 (0.0650)	239 (324)

Pump data

Pump type	Impeller diameter	Max. solids size	Outlet flange pressure (according to ASME B 16.5)	Max. installation depth
	[in. (mm)]	[in. (mm)]	[PSI (PN)]	[ft (m)]
SLV/SEV.30.A30.300.2.52H	8.7 (222)	3.0 (80)	145 (10)	66 (20)

Note: Pumps with stainless steel SuperVortex impellers have the same performance curves as the corresponding cast iron versions.

SLV/SEV.30.A30.335.2.52H

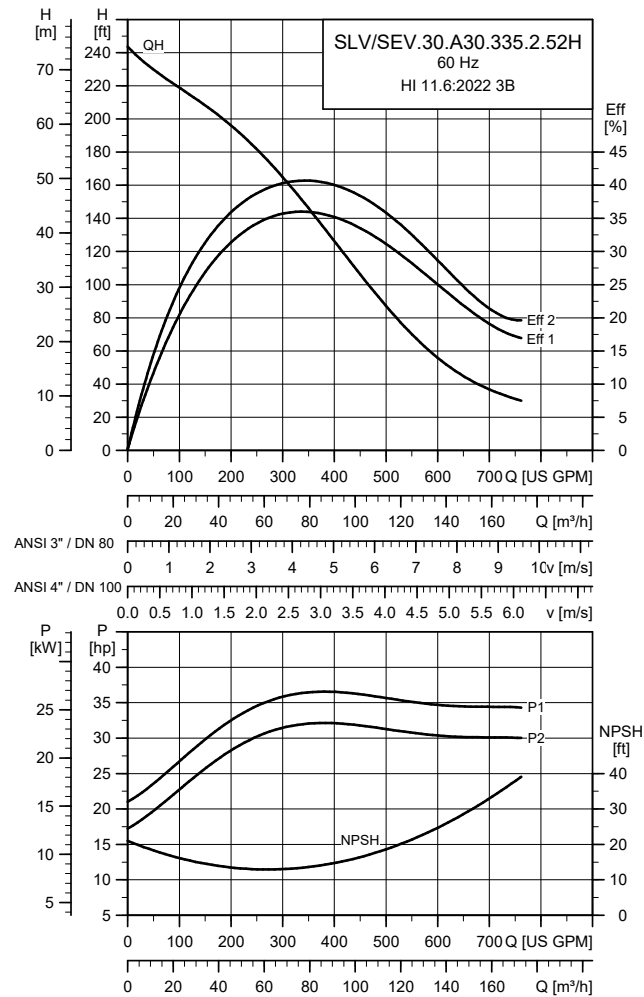

TM054121

Note: Performance grade 3B is the minimum standard to which any pump is tested before shipping from the factory. See, [Variants of customized pumps - Tests](#), for testing options. See, [How to read the performance curves](#).

Electrical data

Pump type	Voltage variant	P1	P2	Number of poles	RPM	Starting method	I_N			$\eta_{\text{motor}} [\%]$			$\text{Cos } \phi$			Moment of inertia [lbf ² (kgm ²)]	Breakdown torque M_{max} [lbf*ft (Nm)]
		[hp (kW)]	[hp (kW)]				[A]	[A]	1/2	3/4	1/1	1/2	3/4	1/1			
SLV/ SEV.30.A30.335.2.52H	60R 3 x 230 V	37.6 (28)	33.5 (25)	2	3551	D	82	723	86	88	89	0.66	0.79	0.86	1.54 (0.0650)	181 (245)	
	61G 3 x 380-480/ 660-690 V	37.6 (28)	33.5 (25)	2	3551	Y/D	54-43/ 31-30	572/ 262	86	88	89	0.59	0.72	0.79	1.54 (0.0650)	171 (232)	
	61M 3 x 575-600 V	37.6 (28)	33.5 (25)	2	3551	D	34-33	405	86	88	89	0.63	0.76	0.83	1.54 (0.0650)	239 (324)	

Pump data

Pump type	Impeller diameter	Max. solids size	Outlet flange pressure (according to ASME B 16.5)	Max. installation depth
	[in. (mm)]	[in. (mm)]	[PSI (PN)]	[ft (m)]
SLV/SEV.30.A30.335.2.52H	9 (228)	3.0 (80)	145 (10)	66 (20)

Note: Pumps with stainless steel SuperVortex impellers have the same performance curves as the corresponding cast iron versions.

SLV/SEV.30.A30.390.2.52H

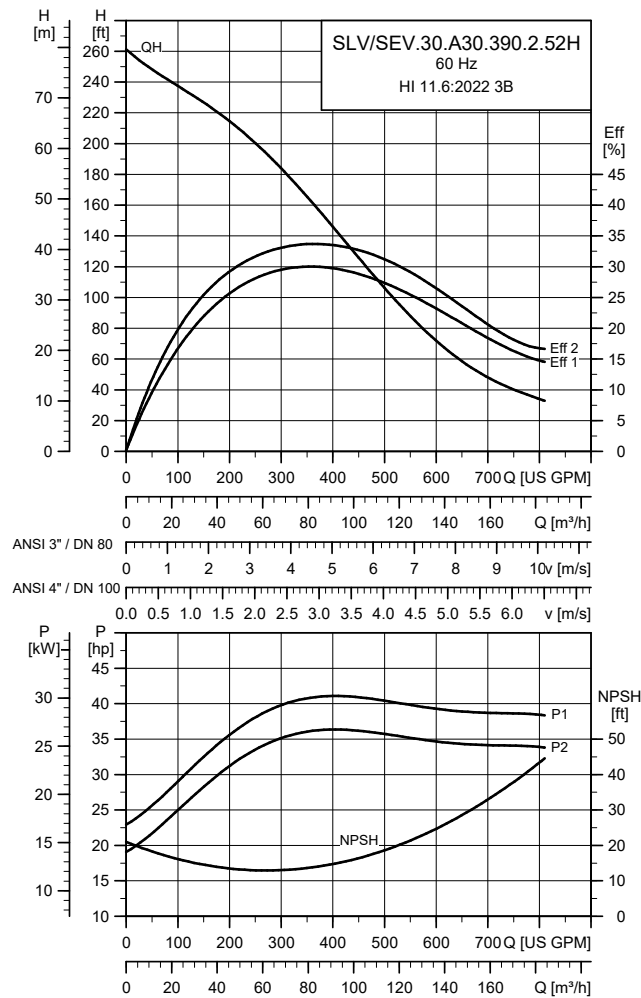

TM054122

Note: Performance grade 3B is the minimum standard to which any pump is tested before shipping from the factory. See, [Variants of customized pumps - Tests](#), for testing options. See, [How to read the performance curves](#).

Electrical data

Pump type	Voltage variant	P1	P2	Number of poles	RPM	Starting method	I _N		η _{motor} [%]			Cos φ			Moment of inertia [lbf ² (kgm ²)]	Breakdown torque M _{max} [lbf ² ft (Nm)]
		[hp (kW)]	[hp (kW)]				[A]	[A]	1/2	3/4	1/1	1/2	3/4	1/1		
SLV/SEV.30.A30.390.2.52H	61G 3 x 380-480/660-690 V	43.6 (33)	38.9 (29)	2	3551	Y/D	61-49/36-34	572/262	87	89	89	0.64	0.76	0.81	1.54 (0.0650)	171 (232)
	61M 3 x 575-600 V	43.6 (33)	38.9 (29)	2	3551	D	39-37	405	87	89	89	0.68	0.80	0.85	1.54 (0.0650)	239 (324)

Note: 39 hp motors, voltage variant 61G must be operated at 460 V to prevent excessive current.

Pump data

Pump type	Impeller diameter	Max. solids size	Outlet flange pressure (according to ASME B 16.5)	Max. installation depth
	[in. (mm)]	[in. (mm)]	[PSI (PN)]	[ft (m)]
SLV/SEV.30.A30.390.2.52H	9.3 (235)	3.0 (80)	145 (10)	66 (20)

Note: Pumps with stainless steel SuperVortex impellers have the same performance curves as the corresponding cast iron versions.

SLV/SEV.30.A30.420.2.52H

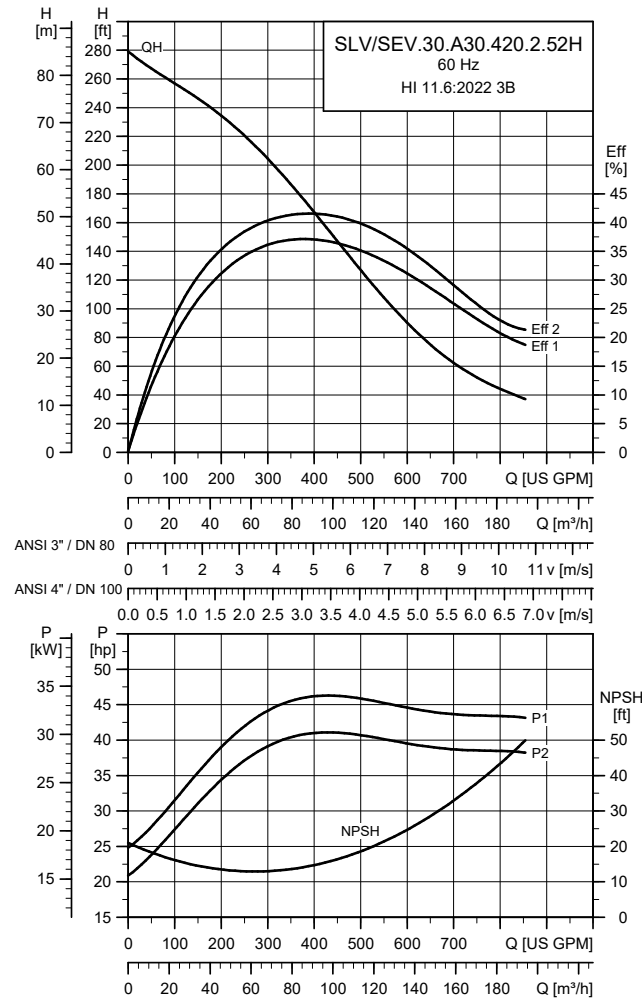

TM054123

Note: Performance grade 3B is the minimum standard to which any pump is tested before shipping from the factory. See, [Variants of customized pumps - Tests](#), for testing options. See, [How to read the performance curves](#).

Electrical data

Pump type	Voltage variant	P1	P2	Number of poles	RPM	Starting method	I_N	I_{start}	η_{motor} [%]			$\cos \phi$			Moment of inertia [lbft ² (kgm ²)]	Breakdown torque M_{max} [lb*ft (Nm)]
		[hp (kW)]	[hp (kW)]						1/2	3/4	1/1	1/2	3/4	1/1		
SLV/SEV.30.A30.420.2.52H	61G 3 x 380-480/660-690 V	46.7 (35)	41.6 (31)	2	3551	Y/D	66-52/38-36	572/262	87	89	89	0.66	0.78	0.81	1.54 (0.0650)	171 (232)
	61M 3 x 575-600 V	46.7 (35)	41.6 (31)	2	3551	D	42-40	405	87	89	89	0.70	0.82	0.85	1.54 (0.0650)	239 (324)

Note: 42 hp motors, voltage variant 61G must be operated at 460 V to prevent excessive current.

Pump data

Pump type	Impeller diameter	Max. solids size	Outlet flange pressure (according to ASME B 16.5)	Max. installation depth
	[in. (mm)]	[in. (mm)]	[PSI (PN)]	[ft (m)]
SLV/SEV.30.A30.420.2.52H	9.5 (242)	3.0 (80)	145 (10)	66 (20)

Note: Pumps with stainless steel SuperVortex impellers have the same performance curves as the corresponding cast iron versions.

Closed S-tube® impeller

SL1/SE1.30.A40.175.2.52S

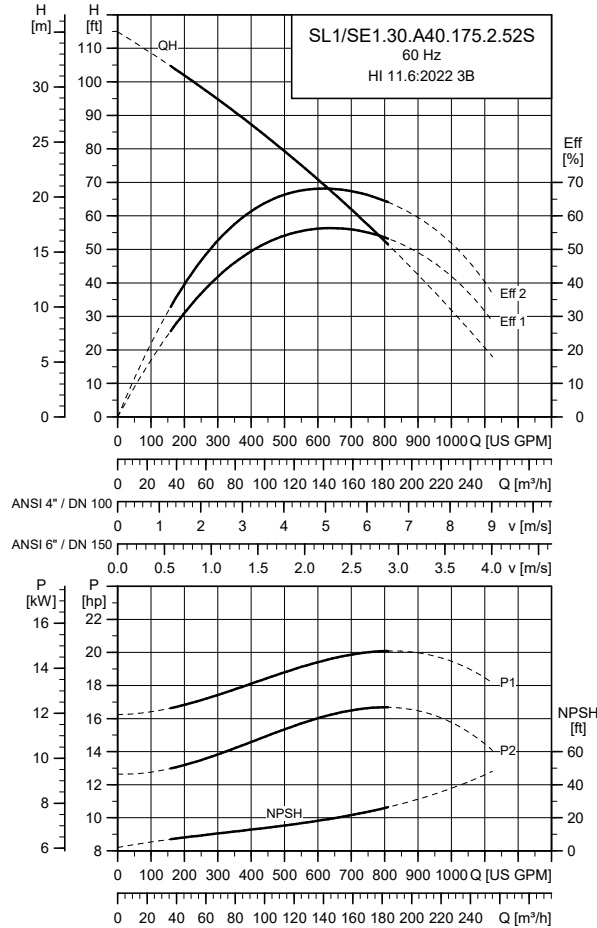

TM066821

Note: Performance grade 3B is the minimum standard to which any pump is tested before shipping from the factory. See, [Variants of customized pumps - Tests](#), for testing options. See, [How to read the performance curves](#).

Electrical data

Pump type	Voltage variant	P1 P2		Number of poles	RPM	Starting method	I _N I _{start} η _{motor} [%]			Cos φ			Moment of inertia [lbf ² (kgm ²)]	Breakdown torque M _{max} [lbf ² (Nm)]
		[hp (kW)]	[hp (kW)]				[A]	[A]	1/2 3/4 1/1	1/2 3/4 1/1				
SL1/ SE1.30.A40.175.2.52S	60S 3 x 208 V	20.5 (15)	17.4 (13)	2	3569	D	51	270	78 82 85	0.73 0.80 0.85	1.16 (0.0490)	59 (80)		
	61R 3 x 230/460 V	20.5 (15)	17.4 (13)	2	3569	Y/D	46/23	308/213	78 82 85	0.73 0.80 0.85	1.16 (0.0490)	74 (100)		
	61M 3 x 575-600 V	20.5 (15)	17.4 (13)	2	3569	D	19-18	155	78 82 85	0.73 0.80 0.85	1.16 (0.0490)	99 (134)		

Pump data

Pump type	Impeller diameter	Max. solids size	Outlet flange pressure (according to ASME B 16.5)	Max. installation depth
	[in. (mm)]	[in. (mm)]	[PSI (PN)]	[ft (m)]
SL1/SE1.30.A40.175.2.52S	6 (153)	3.0 (80)	145 (10)	66 (20)

Note: Pumps with stainless steel closed S-tube® impellers have the same performance curves as the corresponding cast iron versions.

SL1/SE1.30.A40.200.2.52S

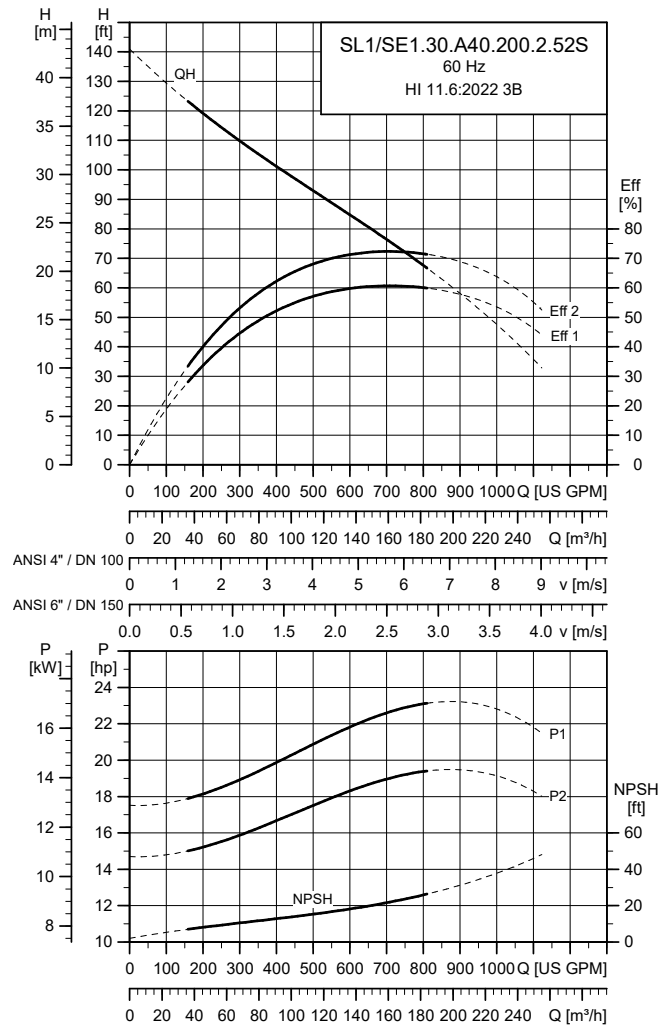

TM066822

Note: Performance grade 3B is the minimum standard to which any pump is tested before shipping from the factory. See, [Variants of customized pumps - Tests](#), for testing options. See, [How to read the performance curves](#).

Electrical data

Pump type	Voltage variant	P1	P2	Number of poles	RPM	Starting method	I _N			I _{start}			η _{motor} [%]			Cos φ			Moment of inertia [lbf ² (kgm ²)]	Breakdown torque M _{max} [lbf ² (Nm)]
		[hp (kW)]	[hp (kW)]				[A]	[A]	[A]	1/2	3/4	1/1	1/2	3/4	1/1					
SL1/ SE1.30.A40.200.2.52S	60S 3 x 208 V	23.5 (18)	20.1 (15)	2	3564	D	57	270	80	84	86	0.75	0.83	0.86	1.16 (0.0490)	59 (80)				
	61R 3 x 230/460 V	23.5 (18)	20.1 (15)	2	3564	Y/D	51/26	308/213	80	84	86	0.75	0.83	0.86	1.16 (0.0490)	74 (100)				
	61M 3 x 575-600 V	23.5 (18)	20.1 (15)	2	3564	D	21-20	155	80	84	86	0.75	0.83	0.86	1.16 (0.0490)	99 (134)				

Pump data

Pump type	Impeller diameter	Max. solids size	Outlet flange pressure (according to ASME B 16.5)	Max. installation depth
	[in. (mm)]	[in. (mm)]	[PSI (PN)]	[ft (m)]
SL1/SE1.30.A40.200.2.52S	6.3 (160)	3.0 (80)	145 (10)	66 (20)

Note: Pumps with stainless steel closed S-tube[®] impellers have the same performance curves as the corresponding cast iron versions.

SL1/SE1.30.A40.230.2.52S

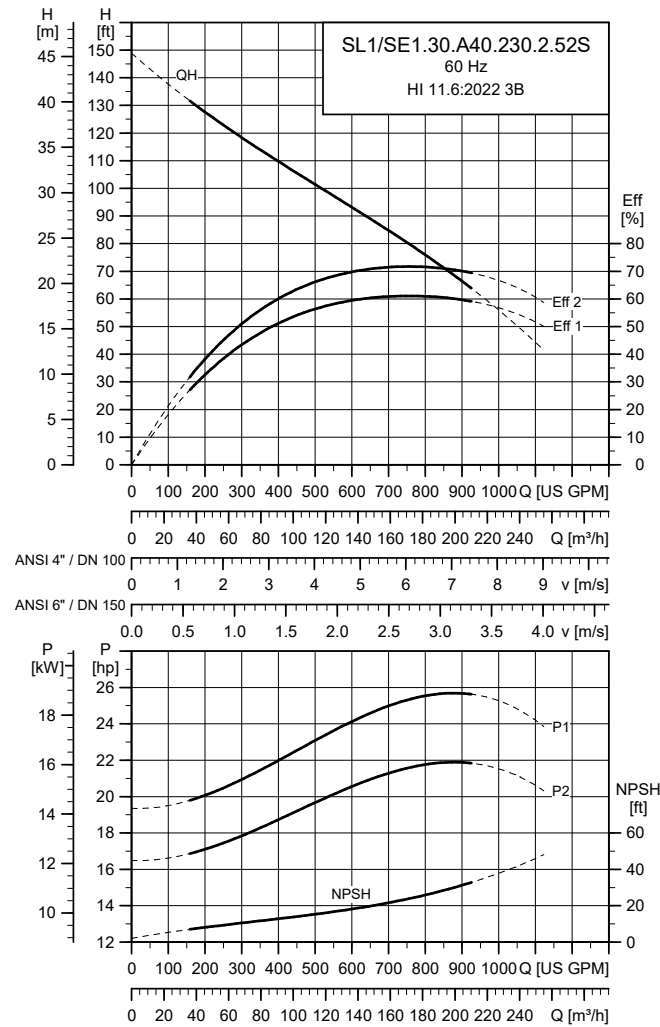

TM066823

Note: Performance grade 3B is the minimum standard to which any pump is tested before shipping from the factory. See, [Variants of customized pumps - Tests](#), for testing options. See, [How to read the performance curves](#).

Electrical data

Pump type	Voltage variant	P1	P2	Number of poles	RPM	Starting method	I_N	I_{start}	η_{motor} [%]			$\cos \varphi$			Moment of inertia [lbf ² (kgm ²)]	Breakdown torque M_{max} [lbf ² (Nm)]
		[hp (kW)]	[hp (kW)]						1/2	3/4	1/1	1/2	3/4	1/1		
SL1/ SE1.30.A40.230.2.52S	60S 3 x 208 V	26.2 (20)	22.8 (17)	2	3567	D	63	477	82	85	87	0.73	0.82	0.86	1.38 (0.0580)	137 (186)
	61R 3 x 230/460 V	26.2 (20)	22.8 (17)	2	3567	Y/D	57/29	373/ 258	82	85	87	0.73	0.82	0.86	1.38 (0.0580)	104 (141)
	61M 3 x 575-600 V	26.2 (20)	22.8 (17)	2	3567	D	23-22	207	82	85	87	0.75	0.84	0.88	1.38 (0.0580)	130 (176)

Pump data

Pump type	Impeller diameter	Max. solids size	Outlet flange pressure (according to ASME B 16.5)	Max. installation depth
	[in. (mm)]	[in. (mm)]	[PSI (PN)]	[ft (m)]
SL1/SE1.30.A40.230.2.52S	6.4 (163)	3.0 (80)	145 (10)	66 (20)

Note: Pumps with stainless steel closed S-tube[®] impellers have the same performance curves as the corresponding cast iron versions.

SL1/SE1.30.A40.250.2.52S

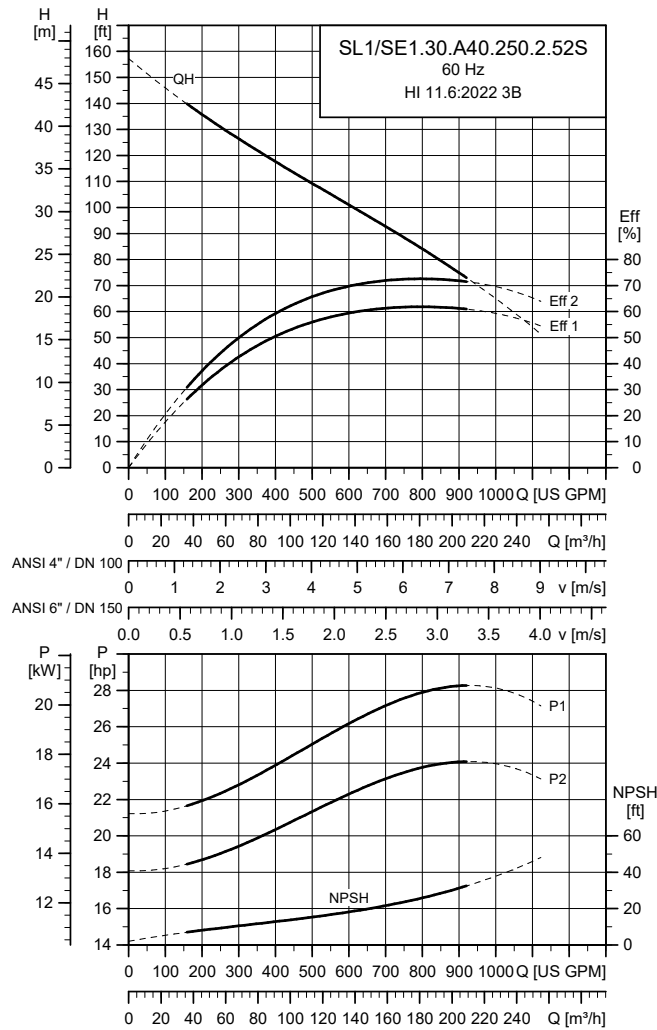

TM066824

Note: Performance grade 3B is the minimum standard to which any pump is tested before shipping from the factory. See, [Variants of customized pumps - Tests](#), for testing options. See, [How to read the performance curves](#).

Electrical data

Pump type	Voltage variant	P1 P2		Number of poles	RPM	Starting method	I _N I _{start} η _{motor} [%]			Cos φ			Moment of inertia [lbf ² (kgm ²)]	Breakdown torque M _{max} [lbf ² ft (Nm)]
		[hp (kW)]	[hp (kW)]				[A]	[A]	1/2 3/4 1/1	1/2 3/4 1/1				
SL1/ SE1.30.A40.250.2.52S	60S 3 x 208 V	28.4 (21)	24.8 (18.5)	2	3565	D	69	477	83 86 87	0.75 0.84 0.86	1.38 (0.0580)	137 (186)		
	61R 3 x 230/460 V	28.4 (21)	24.8 (18.5)	2	3565	Y/D	62/31	373/258	83 86 87	0.75 0.84 0.86	1.38 (0.0580)	104 (141)		
	61M 3 x 575-600 V	28.4 (21)	24.8 (18.5)	2	3565	D	25-24	207	83 86 87	0.77 0.86 0.88	1.38 (0.0580)	130 (176)		

Pump data

Pump type	Impeller diameter	Max. solids size	Outlet flange pressure (according to ASME B 16.5)	Max. installation depth
	[in. (mm)]	[in. (mm)]	[PSI (PN)]	[ft (m)]
SL1/SE1.30.A40.250.2.52S	6.7 (169)	3.0 (80)	145 (10)	66 (20)

Note: Pumps with stainless steel closed S-tube[®] impellers have the same performance curves as the corresponding cast iron versions.

SE1/SL1.30.A40.120.4.52H

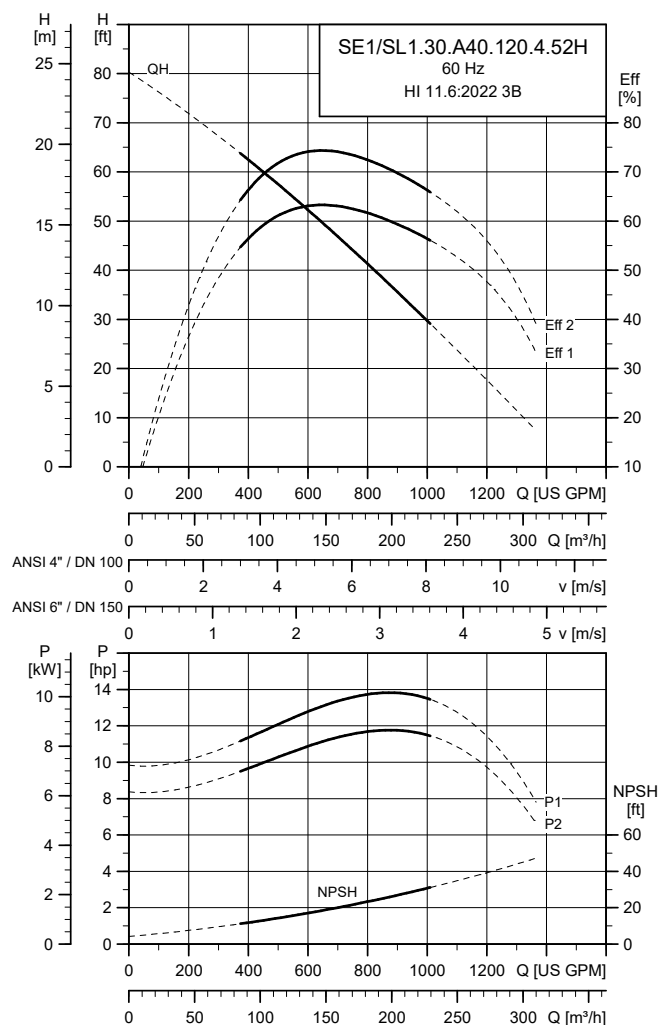

TM066708

Note: Performance grade 3B is the minimum standard to which any pump is tested before shipping from the factory. See, [Variants of customized pumps - Tests](#), for testing options. See, [How to read the performance curves](#).

Electrical data

Pump type	Voltage variant	P1	P2	Number of poles	RPM	Starting method	I_N			$\eta_{\text{motor}} [\%]$			$\text{Cos } \varphi$			Moment of inertia [lbf ² (kgm ²)]	Breakdown torque M_{max} [lbf ² (Nm)]
		[hp (kW)]	[hp (kW)]				[A]	[A]	1/2	3/4	1/1	1/2	3/4	1/1			
SE1/ SL1.30.A40.120.4.52H	60S 3 x 208 V	13.8 (10)	12.1 (9)	4	1785	D	37	332	82	85	88	0.68	0.73	0.78	1.38 (0.0580)	166 (225)	
	61R 3 x 230/460 V	13.8 (10)	12.1 (9)	4	1785	Y/D	32/16	279/192	82	85	88	0.72	0.77	0.82	1.38 (0.0580)	121 (164)	
	61M 3 x 575-600 V	13.8 (10)	12.1 (9)	4	1785	D	14-13	155	82	85	88	0.69	0.74	0.79	1.38 (0.0580)	179 (243)	

Pump data

Pump type	Impeller diameter	Max. solids size	Outlet flange pressure (according to ASME B 16.5)	Max. installation depth
	[in. (mm)]	[in. (mm)]	[PSI (PN)]	[ft (m)]
SE1/SL1.30.A40.120.4.52H	8.9 (226)	3.0 (80)	145 (10)	66 (20)

Note: Pumps with stainless steel closed S-tube[®] impellers have the same performance curves as the corresponding cast iron versions.

SE1/SL1.30.A40.150.4.52H

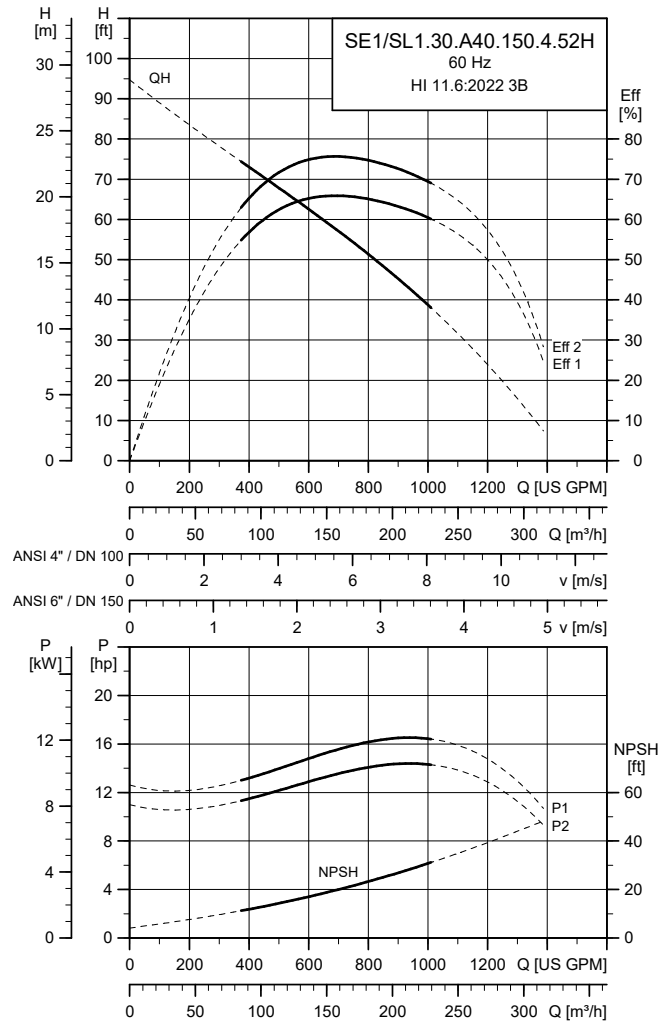

TM066709

Note: Performance grade 3B is the minimum standard to which any pump is tested before shipping from the factory. See, [Variants of customized pumps - Tests](#), for testing options. See, [How to read the performance curves](#).

Electrical data

Pump type	Voltage variant	P1	P2	Number of poles	RPM	Starting method	I_N			η_{motor} [%]			$\cos \phi$			Moment of inertia [lbft ² (kgm ²)]	Breakdown torque M_{max} [lbft (Nm)]
		[hp (kW)]	[hp (kW)]				[A]	[A]	[A]	1/2	3/4	1/1	1/2	3/4	1/1		
SE1/ SL1.30.A40.150.4.52H	60S 3 x 208 V	16.6 (12)	14.8 (11)	4	1782	D	43	332	84	87	89	0.70	0.76	0.82	1.38 (0.0580)	166 (225)	
	61R 3 x 230/460 V	16.6 (12)	14.8 (11)	4	1782	Y/D	37/19	279/192	84	87	89	0.74	0.80	0.86	1.38 (0.0580)	121 (164)	
	61M 3 x 575-600 V	16.6 (12)	14.8 (11)	4	1782	D	16-15	155	84	87	89	0.71	0.77	0.83	1.38 (0.0580)	179 (243)	

Pump data

Pump type	Impeller diameter	Max. solids size	Outlet flange pressure (according to ASME B 16.5)	Max. installation depth
	[in. (mm)]	[in. (mm)]	[PSI (PN)]	[ft (m)]
SE1/SL1.30.A40.150.4.52H	9.4 (238)	3.1 (80)	145 (10)	66 (20)

Note: Pumps with stainless steel closed S-tube[®] impellers have the same performance curves as the corresponding cast iron versions.

SE1/SL1.30.A40.175.4.52H

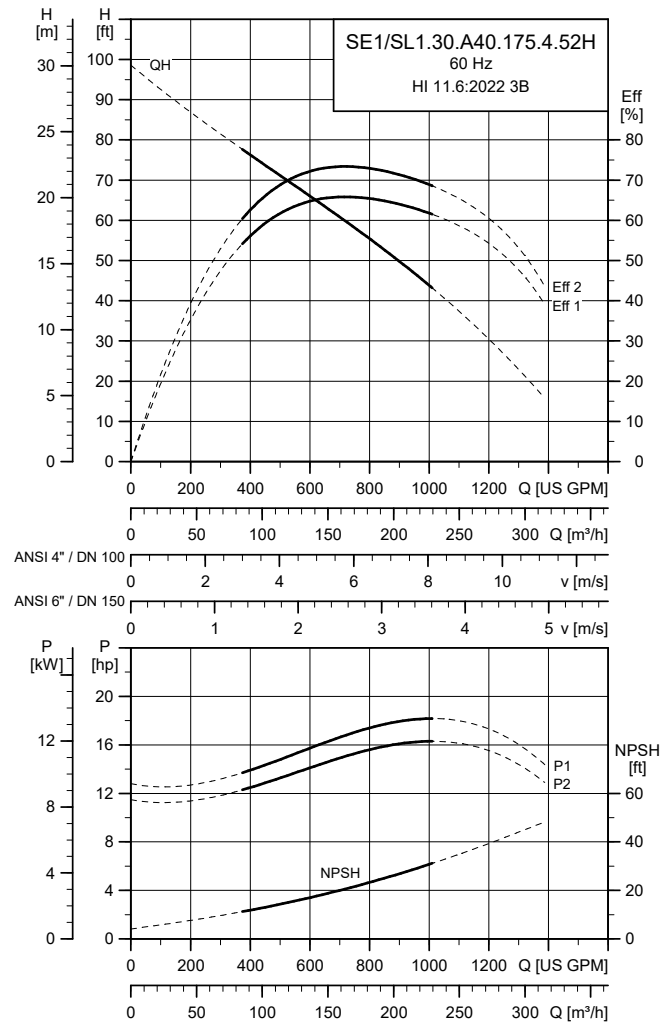

TM066710

Note: Performance grade 3B is the minimum standard to which any pump is tested before shipping from the factory. See, [Variants of customized pumps - Tests](#), for testing options. See, [How to read the performance curves](#).

Electrical data

Pump type	Voltage variant	P1	P2	Number of poles	RPM	Starting method	I_N			$\eta_{\text{motor}} [\%]$			$\text{Cos } \phi$			Moment of inertia [lbft ² (kgm ²)]	Breakdown torque M_{max} [lbft (Nm)]
		[hp (kW)]	[hp (kW)]				[A]	[A]	1/2	3/4	1/1	1/2	3/4	1/1			
SE1/ SL1.30.A40.175.4.52H	60S 3 x 208 V	19.3 (14)	17.4 (13)	4	1785	D	50	420	86	89	90	0.64	0.75	0.81	1.78 (0.0750)	260 (353)	
	61R 3 x 230/460 V	19.3 (14)	17.4 (13)	4	1785	Y/D	44/22	420/ 290	86	89	90	0.66	0.77	0.83	1.78 (0.0750)	184 (249)	
	61M 3 x 575-600 V	19.3 (14)	17.4 (13)	4	1785	D	18-17	207	86	89	90	0.66	0.77	0.83	1.78 (0.0750)	144 (195)	

Pump data

Pump type	Impeller diameter	Max. solids size	Outlet flange pressure (according to ASME B 16.5)	Max. installation depth
	[in. (mm)]	[in. (mm)]	[PSI (PN)]	[ft (m)]
SE1/SL1.30.A40.175.4.52H	9.5 (242)	3.0 (80)	145 (10)	66 (20)

Note: Pumps with stainless steel closed S-tube[®] impellers have the same performance curves as the corresponding cast iron versions.

SE1/SL1.30.A40.200.4.52H

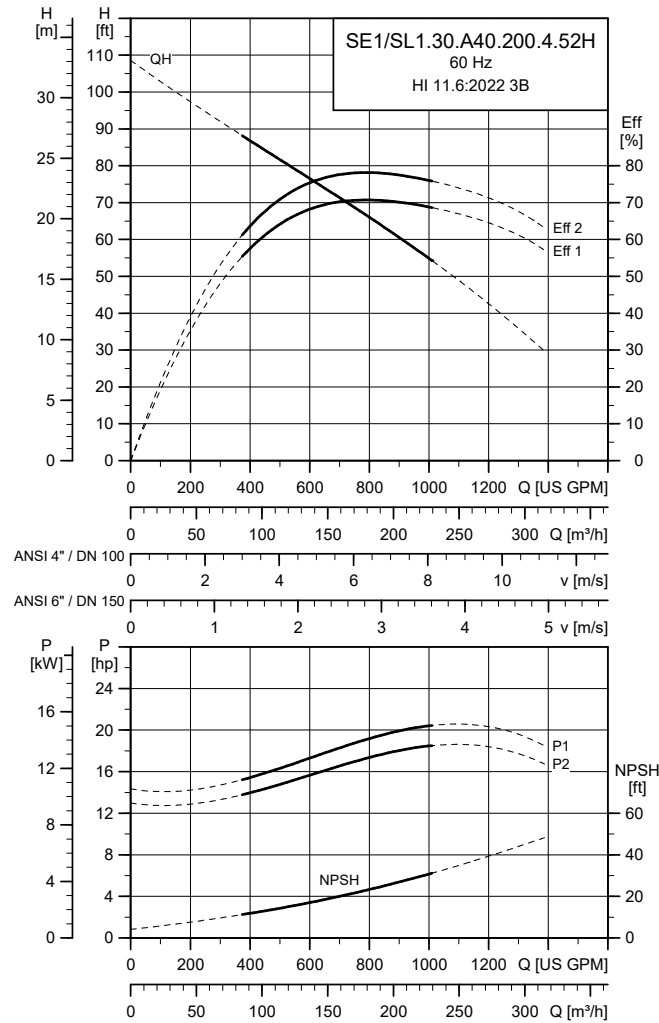

TM066711

Note: Performance grade 3B is the minimum standard to which any pump is tested before shipping from the factory. See, [Variants of customized pumps - Tests](#), for testing options. See, [How to read the performance curves](#).

Electrical data

Pump type	Voltage variant	P1	P2	Number of poles	RPM	Starting method	I _N			η _{motor} [%]			Cos φ			Moment of inertia [lbft ² (kgm ²)]	Breakdown torque M _{max} [lbft ² (Nm)]
		[hp (kW)]	[hp (kW)]				[A]	[A]	1/2	3/4	1/1	1/2	3/4	1/1			
SE1/ SL1.30.A40.200.4.52H	60S 3 x 208 V	22.3 (17)	20.1 (15)	4	1783	D	57	420	87	90	90	0.68	0.78	0.82	1.78 (0.0750)	260 (353)	
	61R 3 x 230/460 V	22.3 (17)	20.1 (15)	4	1783	Y/D	50/25	420/290	87	90	90	0.70	0.80	0.84	1.78 (0.0750)	184 (249)	
	61M 3 x 575-600 V	22.3 (17)	20.1 (15)	4	1783	D	20-20	207	87	90	90	0.70	0.80	0.84	1.78 (0.0750)	144 (195)	

Pump data

Pump type	Impeller diameter	Max. solids size	Outlet flange pressure (according to ASME B 16.5)	Max. installation depth
	[in. (mm)]	[in. (mm)]	[PSI (PN)]	[ft (m)]
SE1/SL1.30.A40.200.4.52H	9.9 (251)	3.0 (80)	145 (10)	66 (20)

Note: Pumps with stainless steel closed S-tube[®] impellers have the same performance curves as the corresponding cast iron versions.

SL1/SE1.35.A40.245.4.52H

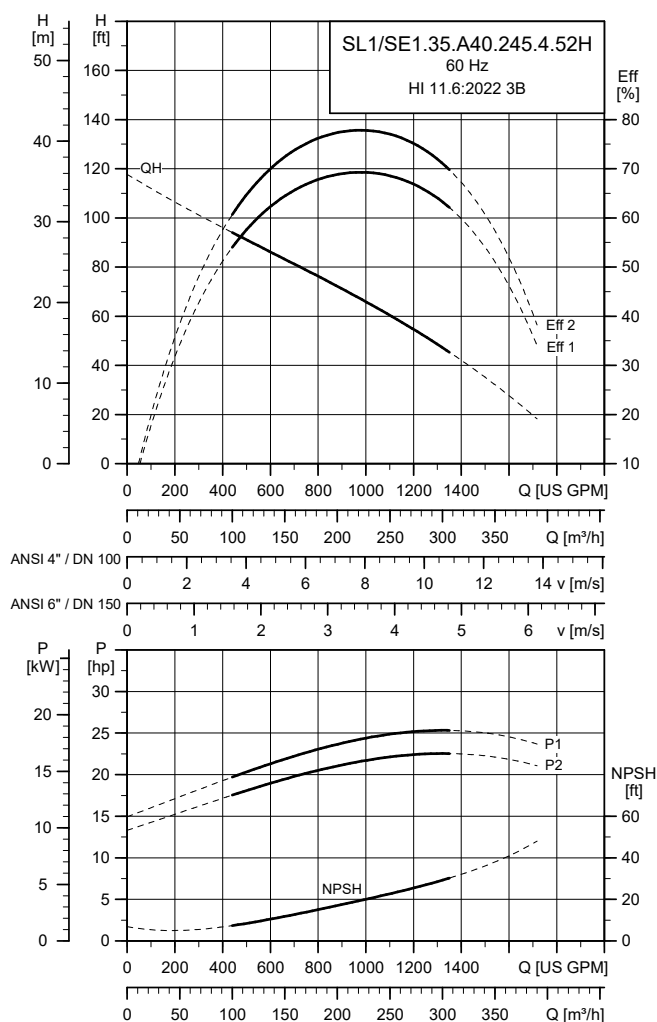

TM066825

Note: Performance grade 3B is the minimum standard to which any pump is tested before shipping from the factory. See, [Variants of customized pumps - Tests](#), for testing options. See, [How to read the performance curves](#).

Electrical data

Pump type	Voltage variant	P1	P2	Number of poles	RPM	Starting method	I_N			$\eta_{\text{motor}} [\%]$			$\text{Cos } \varphi$			Moment of inertia [lbft ² (kgm ²)]	Breakdown torque M_{max} [lbft ² (Nm)]
		[hp (kW)]	[hp (kW)]				[A]	[A]	1/2	3/4	1/1	1/2	3/4	1/1			
SL1/ SE1.35.A40.245.4.52H	60S 3 x 208 V	27.1 (20)	24.1 (18)	4	1783	D	70	830	87	88	89	0.66	0.74	0.81	1.78 (0.0750)	371 (503)	
	61R 3 x 230/460 V	27.1 (20)	24.1 (18)	4	1783	Y/D	64/32	534/ 363	87	88	89	0.66	0.74	0.81	1.78 (0.0750)	260 (353)	
	61M 3 x 575-600 V	27.1 (20)	24.1 (18)	4	1783	D	26-25	292	87	88	89	0.64	0.72	0.79	1.78 (0.0750)	320 (434)	

Pump data

Pump type	Impeller diameter	Max. solids size	Outlet flange pressure (according to ASME B 16.5)	Max. installation depth
	[in. (mm)]	[in. (mm)]	[PSI (PN)]	[ft (m)]
SL1/SE1.35.A40.245.4.52H	10.5 (266)	3.5 (85)	145 (10)	66 (20)

Note: Pumps with stainless steel closed S-tube[®] impellers have the same performance curves as the corresponding cast iron versions.

SL1/SE1.35.A40.270.4.52H

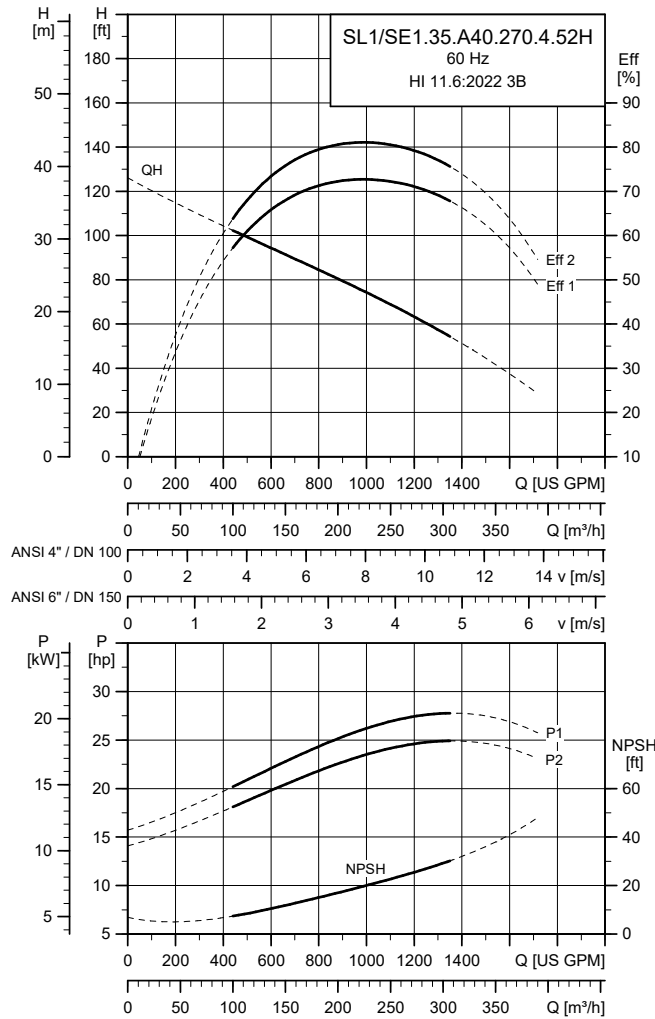

TM066826

Note: Performance grade 3B is the minimum standard to which any pump is tested before shipping from the factory. See, [Variants of customized pumps - Tests](#), for testing options. See, [How to read the performance curves](#).

Electrical data

Pump type	Voltage variant	P1	P2	Number of poles	RPM	Starting method	I_N			$\eta_{\text{motor}} [\%]$			$\text{Cos } \phi$			Moment of inertia [lbf ² (kgm ²)]	Breakdown torque M_{max} [lbf ² ft (Nm)]
		[hp (kW)]	[hp (kW)]				[A]	[A]	1/2	3/4	1/1	1/2	3/4	1/1			
SL1/ SE1.35.A40.270.4.52H	60S 3 x 208 V	30.0 (22)	26.8 (20)	4	1782	D	76	830	88	88	89	0.68	0.77	0.83	1.78 (0.0750)	371 (503)	
	61R 3 x 230/460 V	30.0 (22)	26.8 (20)	4	1782	Y/D	68/34	534/363	88	88	89	0.68	0.77	0.83	1.78 (0.0750)	260 (353)	
	61M 3 x 575-600 V	30.0 (22)	26.8 (20)	4	1782	D	28-27	292	88	88	89	0.66	0.75	0.81	1.78 (0.0750)	320 (434)	

Pump data

Pump type	Impeller diameter	Max. solids size	Outlet flange pressure (according to ASME B 16.5)	Max. installation depth
	[in. (mm)]	[in. (mm)]	[PSI (PN)]	[ft (m)]
SL1/SE1.35.A40.270.4.52H	10.9 (278)	3.5 (85)	145 (10)	66 (20)

Note: Pumps with stainless steel closed S-tube[®] impellers have the same performance curves as the corresponding cast iron versions.

SL1/SE1.35.A40.300.4.52H

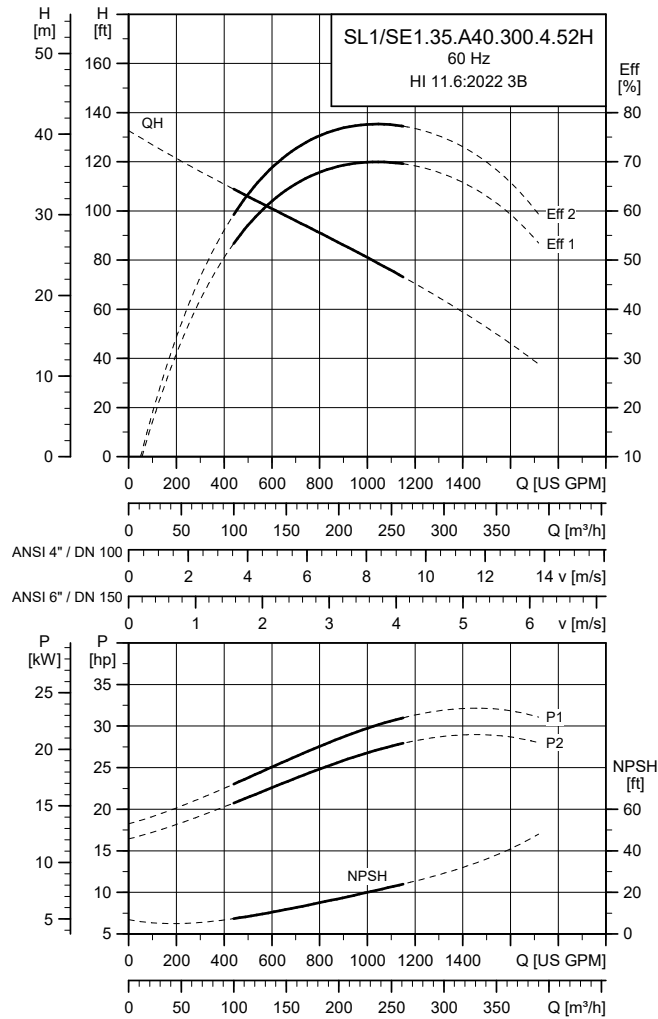

TM066627

Note: Performance grade 3B is the minimum standard to which any pump is tested before shipping from the factory. See, [Variants of customized pumps - Tests](#), for testing options. See, [How to read the performance curves](#).

Electrical data

Pump type	Voltage variant	P1	P2	Number of poles	RPM	Starting method	I _N		η _{motor} [%]			Cos φ			Moment of inertia [lbft ² (kgm ²)]	Breakdown torque M _{max} [lbft ² (Nm)]
		[hp (kW)]	[hp (kW)]				[A]	[A]	1/2	3/4	1/1	1/2	3/4	1/1		
SL1/ SE1.35.A40.300.4.52H	60R 3 x 230 V	32.9 (25)	29.5 (22)	4	1779	D	73	534	88	89	90	0.70	0.79	0.84	1.78 (0.0750)	260 (353)
	61G 3 x 380-480/ 660-690 V	32.9 (25)	29.5 (22)	4	1779	Y/D	48-38/ 28-27	379/ 174	88	89	90	0.64	0.73	0.78	1.78 (0.0750)	252 (342)
	61M 3 x 575-600 V	32.9 (25)	29.5 (22)	4	1779	D	30-29	292	88	89	90	0.68	0.77	0.82	1.78 (0.0750)	320 (434)

Pump data

Pump type	Impeller diameter	Max. solids size	Outlet flange pressure (according to ASME B 16.5)	Max. installation depth
	[in. (mm)]	[in. (mm)]	[PSI (PN)]	[ft (m)]
SL1/SE1.35.A40.300.4.52H	11 (281)	3.5 (85)	145 (10)	66 (20)

Note: Pumps with stainless steel closed S-tube[®] impellers have the same performance curves as the corresponding cast iron versions.

SL1/SE1.35.A40.330.4.52H

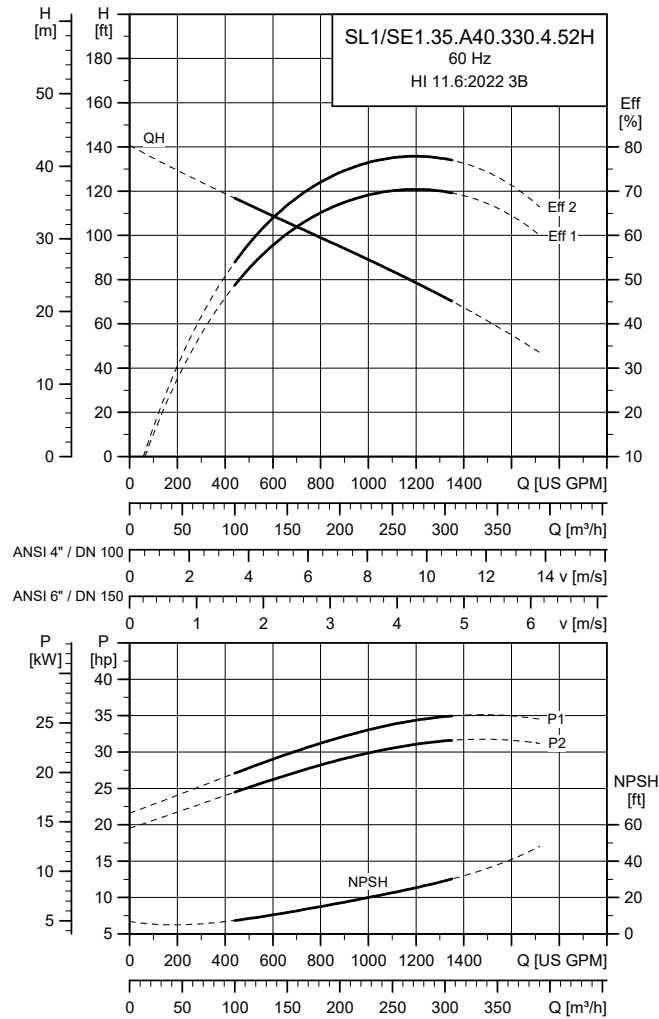

TM066828

Note: Performance grade 3B is the minimum standard to which any pump is tested before shipping from the factory. See, [Variants of customized pumps - Tests](#), for testing options. See, [How to read the performance curves](#).

Electrical data

Pump type	Voltage variant	P1	P2	Number of poles	RPM	Starting method	I _N			I _{start}			η _{motor} [%]			Cos φ			Moment of inertia [lbft ² (kgm ²)]	Breakdown torque M _{max} [lbft ² (Nm)]
		[hp (kW)]	[hp (kW)]				[A]	[A]	[A]	1/2	3/4	1/1	1/2	3/4	1/1					
SL1/ SE1.35.A40.330.4.52H	60R 3 x 230 V	36.5 (27)	32.9 (24.5)	4	1777	D	80	534	88	89	90	0.72	0.81	0.86	1.78 (0.0750)	260 (353)				
	61G 3 x 380-480/ 660-690 V	36.5 (27)	32.9 (24.5)	4	1777	Y/D	52-41/ 30-29	379/ 174	88	89	90	0.66	0.75	0.80	1.78 (0.0750)	252 (342)				
	61M 3 x 575-600 V	36.5 (27)	32.9 (24.5)	4	1777	D	33-32	292	88	89	90	0.70	0.79	0.84	1.78 (0.0750)	320 (434)				

Pump data

Pump type	Impeller diameter	Max. solids size	Outlet flange pressure (according to ASME B 16.5)	Max. installation depth
	[in. (mm)]	[in. (mm)]	[PSI (PN)]	[ft (m)]
SL1/SE1.35.A40.330.4.52H	11.5 (292)	3.5 (85)	145 (10)	66 (20)

Note: Pumps with stainless steel closed S-tube[®] impellers have the same performance curves as the corresponding cast iron versions.

SE1/SL1.30.A60.120.4.52H

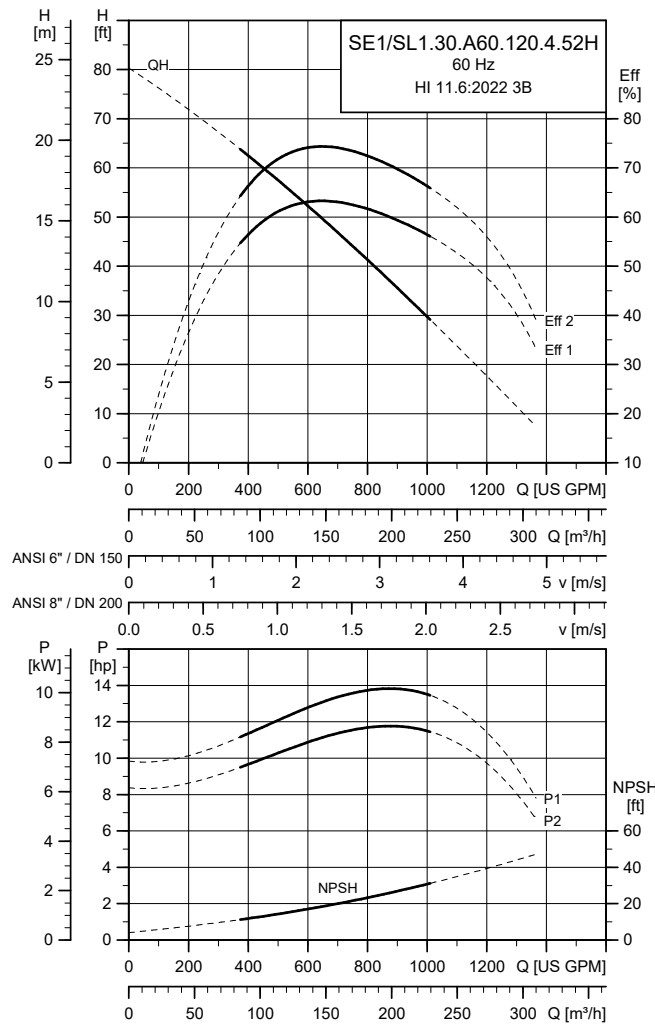

TM1062272

Note: Performance grade 3B is the minimum standard to which any pump is tested before shipping from the factory. See, [Variants of customized pumps - Tests](#), for testing options. See, [How to read the performance curves](#).

Electrical data

Pump type	Voltage variant	P1	P2	Number of poles	RPM	Starting method	I_N			I_{start}			$\eta_{motor} [\%]$			$\cos \phi$			Moment of inertia [lbf ² (kgm ²)]	Breakdown torque M_{max} [lbf ² ft (Nm)]
		[hp (kW)]	[hp (kW)]				[A]	[A]	[A]	[A]	[A]	[A]	[A]	[A]	[A]	[A]	[A]	[A]		
SE1/ SL1.30.A60.120.4.52H	60S 3 x 208 V	13.8 (10)	12.1 (9)	4	1785	D	37	332	82	85	88	0.68	0.73	0.78	1.38 (0.0580)	166 (225)				
	61R 3 x 230/460 V	13.8 (10)	12.1 (9)	4	1785	Y/D	32/16	279/192	82	85	88	0.72	0.77	0.82	1.38 (0.0580)	121 (164)				
	61M 3 x 575-600 V	13.8 (10)	12.1 (9)	4	1785	D	14-13	155	82	85	88	0.69	0.74	0.79	1.38 (0.0580)	179 (243)				

Pump data

Pump type	Impeller diameter	Max. solids size	Outlet flange pressure (according to ASME B 16.5)	Max. installation depth
	[in. (mm)]	[in. (mm)]	[PSI (PN)]	[ft (m)]
SE1/SL1.30.A60.120.4.52H	8.9 (226)	3.0 (80)	145 (10)	66 (20)

Note: Pumps with stainless steel closed S-tube[®] impellers have the same performance curves as the corresponding cast iron versions.

SE1/SL1.30.A60.150.4.52H

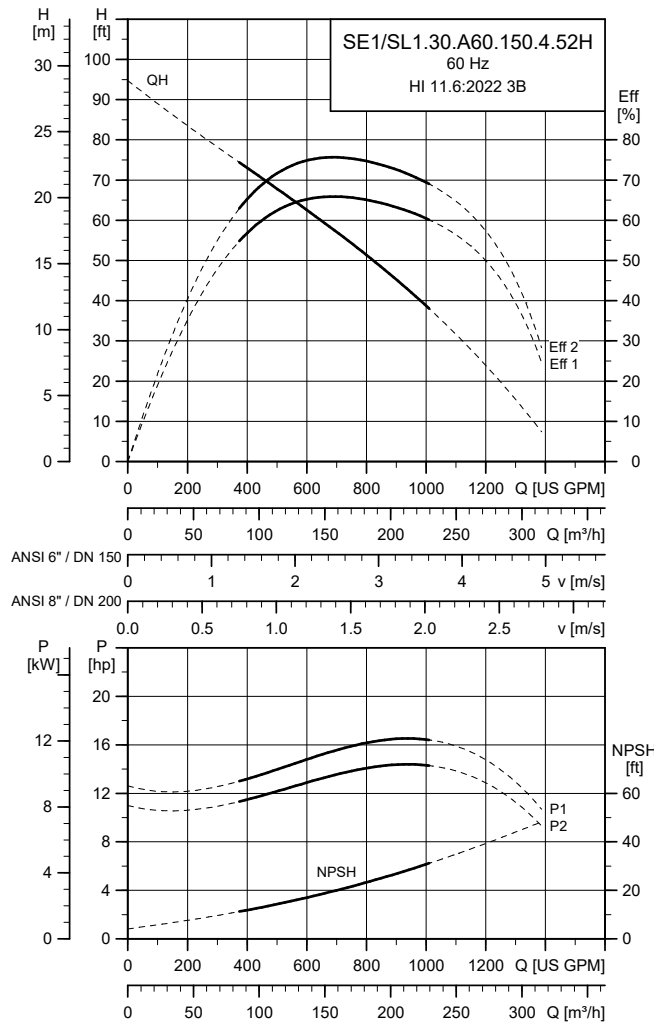

TM062273

Note: Performance grade 3B is the minimum standard to which any pump is tested before shipping from the factory. See, [Variants of customized pumps - Tests](#), for testing options. See, [How to read the performance curves](#).

Electrical data

Pump type	Voltage variant	P1	P2	Number of poles	RPM	Starting method	I _N		η _{motor} [%]			Cos φ			Moment of inertia [lbf ² (kgm ²)]	Breakdown torque M _{max} [lbf ² ft (Nm)]
		[hp (kW)]	[hp (kW)]				[A]	[A]	1/2	3/4	1/1	1/2	3/4	1/1		
SE1/ SL1.30.A60.150.4.52H	60S 3 x 208 V	16.6 (12)	14.8 (11)	4	1782	D	43	332	84	87	89	0.70	0.76	0.82	1.38 (0.0580)	166 (225)
	61R 3 x 230/460 V	16.6 (12)	14.8 (11)	4	1782	Y/D	37/19	279/192	84	87	89	0.74	0.80	0.86	1.38 (0.0580)	121 (164)
	61M 3 x 575-600 V	16.6 (12)	14.8 (11)	4	1782	D	16-15	155	84	87	89	0.71	0.77	0.83	1.38 (0.0580)	179 (243)

Pump data

Pump type	Impeller diameter	Max. solids size	Outlet flange pressure (according to ASME B 16.5)	Max. installation depth
	[in. (mm)]	[in. (mm)]	[PSI (PN)]	[ft (m)]
SE1/SL1.30.A60.150.4.52H	9.4 (238)	3.0 (80)	145 (10)	66 (20)

Note: Pumps with stainless steel closed S-tube[®] impellers have the same performance curves as the corresponding cast iron versions.

SE1/SL1.30.A60.175.4.52H

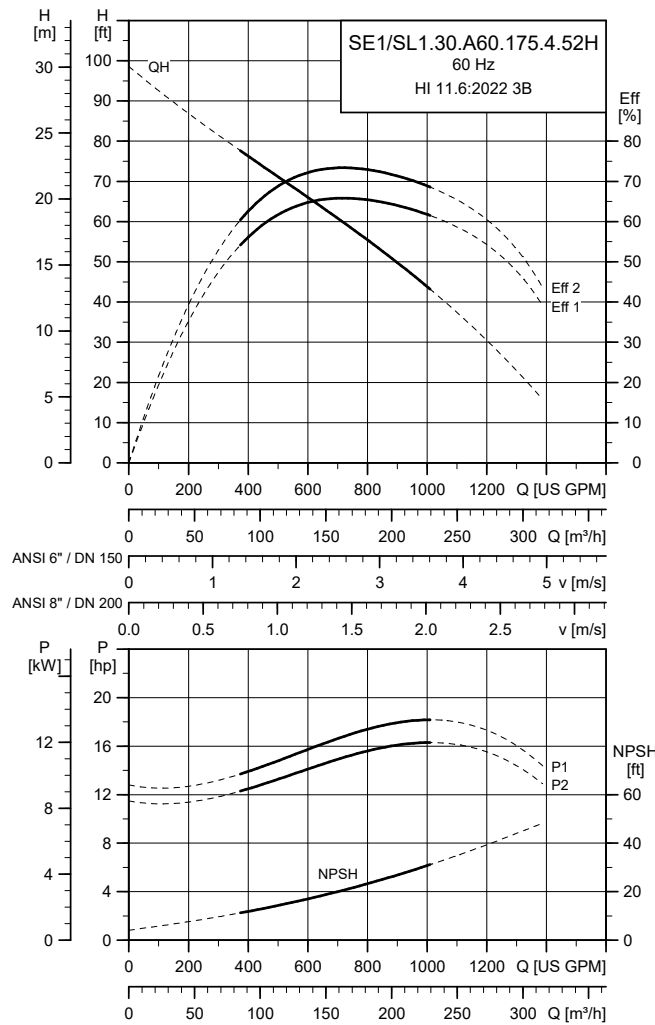

TM062274

Note: Performance grade 3B is the minimum standard to which any pump is tested before shipping from the factory. See, [Variants of customized pumps - Tests](#), for testing options. See, [How to read the performance curves](#).

Electrical data

Pump type	Voltage variant	P1	P2	Number of poles	RPM	Starting method	I_N			$\eta_{\text{motor}} [\%]$			$\text{Cos } \varphi$			Moment of inertia [lbf ² (kgm ²)]	Breakdown torque M_{max} [lbf ² (Nm)]
		[hp (kW)]	[hp (kW)]				[A]	[A]	1/2	3/4	1/1	1/2	3/4	1/1			
SE1/ SL1.30.A60.175.4.52H	60S 3 x 208 V	19.3 (14)	17.4 (13)	4	1785	D	50	420	86	89	90	0.64	0.75	0.81	1.78 (0.0750)	260 (353)	
	61R 3 x 230/460 V	19.3 (14)	17.4 (13)	4	1785	Y/D	44/22	420/ 290	86	89	90	0.66	0.77	0.83	1.78 (0.0750)	184 (249)	
	61M 3 x 575-600 V	19.3 (14)	17.4 (13)	4	1785	D	18-17	207	86	89	90	0.66	0.77	0.83	1.78 (0.0750)	144 (195)	

Pump data

Pump type	Impeller diameter	Max. solids size	Outlet flange pressure (according to ASME B 16.5)	Max. installation depth
	[in. (mm)]	[in. (mm)]	[PSI (PN)]	[ft (m)]
SE1/SL1.30.A60.175.4.52H	9.5 (242)	3.0 (80)	145 (10)	66 (20)

Note: Pumps with stainless steel closed S-tube[®] impellers have the same performance curves as the corresponding cast iron versions.

SE1/SL1.30.A60.200.4.52H

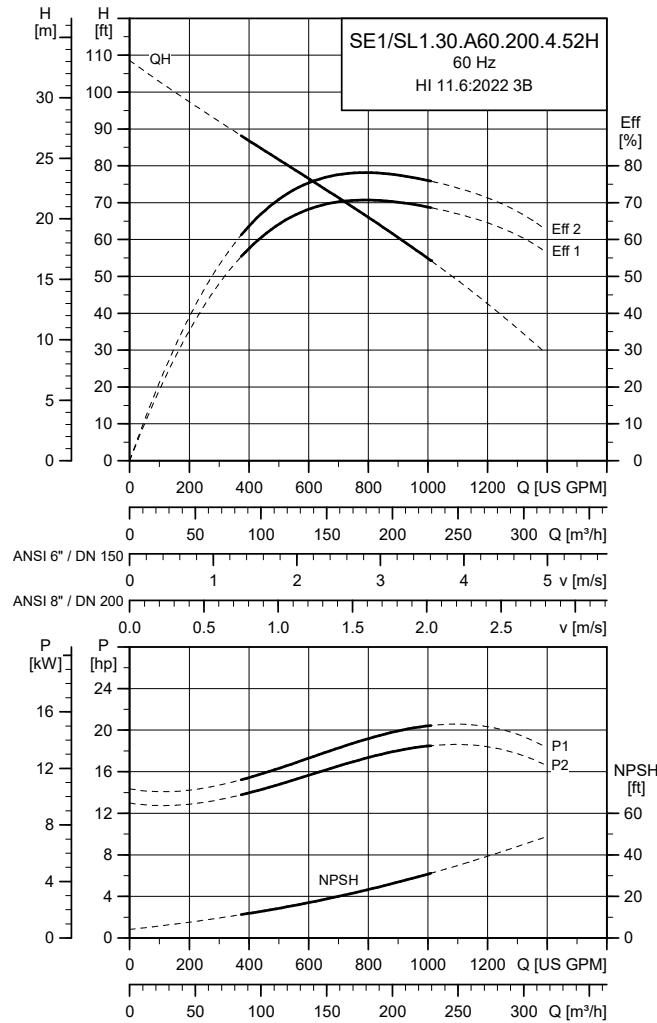

TM062275

Note: Performance grade 3B is the minimum standard to which any pump is tested before shipping from the factory. See, [Variants of customized pumps - Tests](#), for testing options. See, [How to read the performance curves](#).

Electrical data

Pump type	Voltage variant	P1	P2	Number of poles	RPM	Starting method	I _N		η _{motor} [%]			Cos φ			Moment of inertia [lbf ² (kgm ²)]	Breakdown torque M _{max} [lbf ² ft (Nm)]
		[hp (kW)]	[hp (kW)]				[A]	[A]	1/2	3/4	1/1	1/2	3/4	1/1		
SE1/ SL1.30.A60.200.4.52H	60S 3 x 208 V	22.3 (17)	20.1 (15)	4	1783	D	57	420	87	90	90	0.68	0.78	0.82	1.78 (0.0750)	260 (353)
	61R 3 x 230/460 V	22.3 (17)	20.1 (15)	4	1783	Y/D	50/25	420/290	87	90	90	0.70	0.80	0.84	1.78 (0.0750)	184 (249)
	61M 3 x 575-600 V	22.3 (17)	20.1 (15)	4	1783	D	20-20	207	87	90	90	0.70	0.80	0.84	1.78 (0.0750)	144 (195)

Pump data

Pump type	Impeller diameter	Max. solids size	Outlet flange pressure (according to ASME B 16.5)	Max. installation depth
	[in. (mm)]	[in. (mm)]	[PSI (PN)]	[ft (m)]
SE1/SL1.30.A60.200.4.52H	9.9 (251)	3.0 (80)	145 (10)	66 (20)

Note: Pumps with stainless steel closed S-tube[®] impellers have the same performance curves as the corresponding cast iron versions.

SL1/SE1.35.A60.245.4.52H

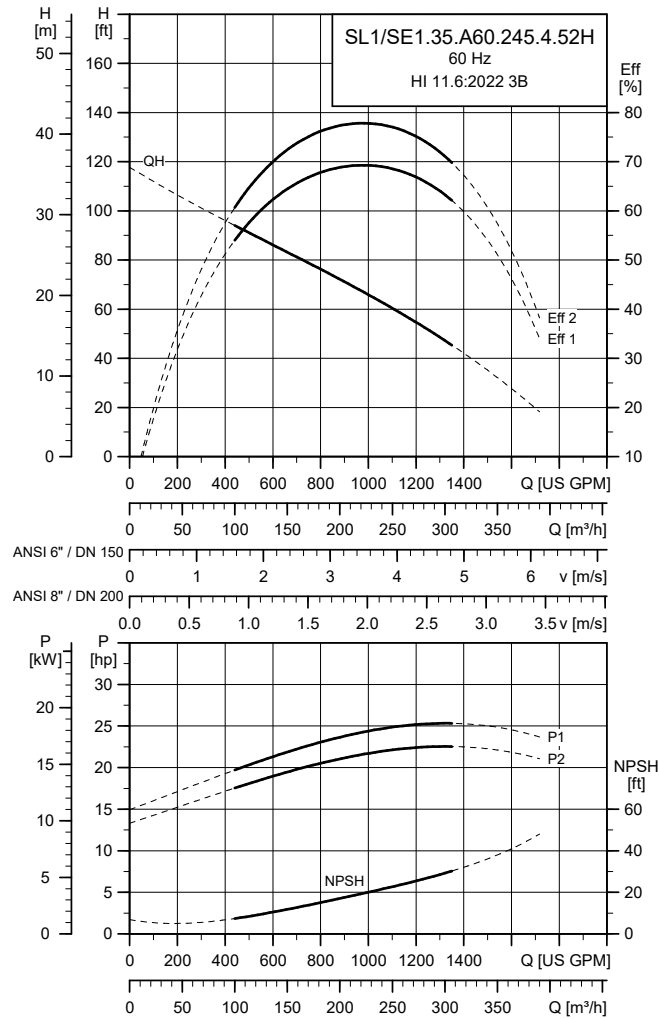

TM054108

Note: Performance grade 3B is the minimum standard to which any pump is tested before shipping from the factory. See, [Variants of customized pumps - Tests](#), for testing options. See, [How to read the performance curves](#).

Electrical data

Pump type	Voltage variant	P1 [hp (kW)]	P2 [hp (kW)]	Number of poles	RPM	Starting method	I_N [A]	I_{start} [A]	η_{motor} [%]			$\cos \phi$			Moment of inertia [lbft ² (kgm ²)]	Breakdown torque M_{max} [lbft (Nm)]
									1/2	3/4	1/1	1/2	3/4	1/1		
SL1/ SE1.35.A60.245.4.52H	60S 3 x 208 V	27.1 (20)	24.1 (18)	4	1783	D	70	830	87	88	89	0.66	0.74	0.81	1.78 (0.0750)	371 (503)
	61R 3 x 230/460 V	27.1 (20)	24.1 (18)	4	1783	Y/D	64/32	534/ 363	87	88	89	0.66	0.74	0.81	1.78 (0.0750)	260 (353)
	61M 3 x 575-600 V	27.1 (20)	24.1 (18)	4	1783	D	26-25	292	87	88	89	0.64	0.72	0.79	1.78 (0.0750)	320 (434)

Pump data

Pump type	Impeller diameter	Max. solids size	Outlet flange pressure (according to ASME B 16.5)	Max. installation depth
	[in. (mm)]	[in. (mm)]	[PSI (PN)]	[ft (m)]
SL1/SE1.35.A60.245.4.52H	10.5 (266)	3.5 (85)	145 (10)	66 (20)

Note: Pumps with stainless steel closed S-tube[®] impellers have the same performance curves as the corresponding cast iron versions.

SL1/SE1.35.A60.270.4.52H

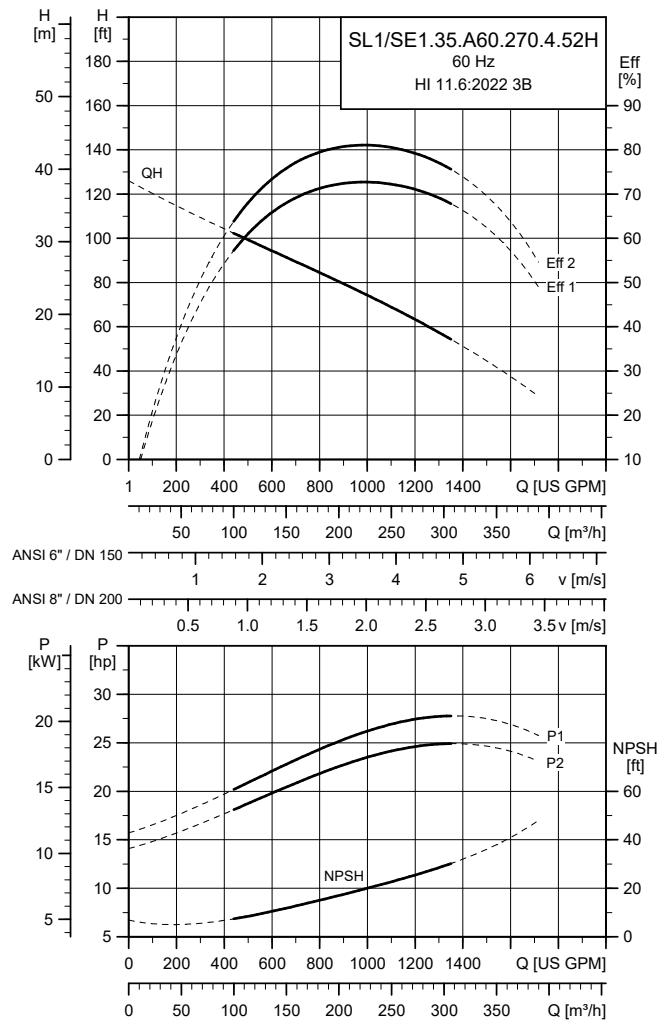

TM054109

Note: Performance grade 3B is the minimum standard to which any pump is tested before shipping from the factory. See, [Variants of customized pumps - Tests](#), for testing options. See, [How to read the performance curves](#).

Electrical data

Pump type	Voltage variant	P1	P2	Number of poles	RPM	Starting method	I _N	I _{start}	η _{motor} [%]			Cos φ			Moment of inertia [lbf ² (kgm ²)]	Breakdown torque M _{max} [lbf*ft (Nm)]
		[hp (kW)]	[hp (kW)]						1/2	3/4	1/1	1/2	3/4	1/1		
SL1/ SE1.35.A60.270.4.52H	60S 3 x 208 V	30.0 (22)	26.8 (20)	4	1782	D	76	830	88	88	89	0.68	0.77	0.83	1.78 (0.0750)	371 (503)
	61R 3 x 230/460 V	30.0 (22)	26.8 (20)	4	1782	Y/D	68/34	534/ 363	88	88	89	0.68	0.77	0.83	1.78 (0.0750)	260 (353)
	61M 3 x 575-600 V	30.0 (22)	26.8 (20)	4	1782	D	28-27	292	88	88	89	0.66	0.75	0.81	1.78 (0.0750)	320 (434)

Pump data

Pump type	Impeller diameter	Max. solids size	Outlet flange pressure (according to ASME B 16.5)	Max. installation depth
	[in. (mm)]	[in. (mm)]	[PSI (PN)]	[ft (m)]
SL1/SE1.35.A60.270.4.52H	10.9 (278)	3.5 (85)	145 (10)	66 (20)

Note: Pumps with stainless steel closed S-tube® impellers have the same performance curves as the corresponding cast iron versions.

SL1/SE1.35.A60.300.4.52H

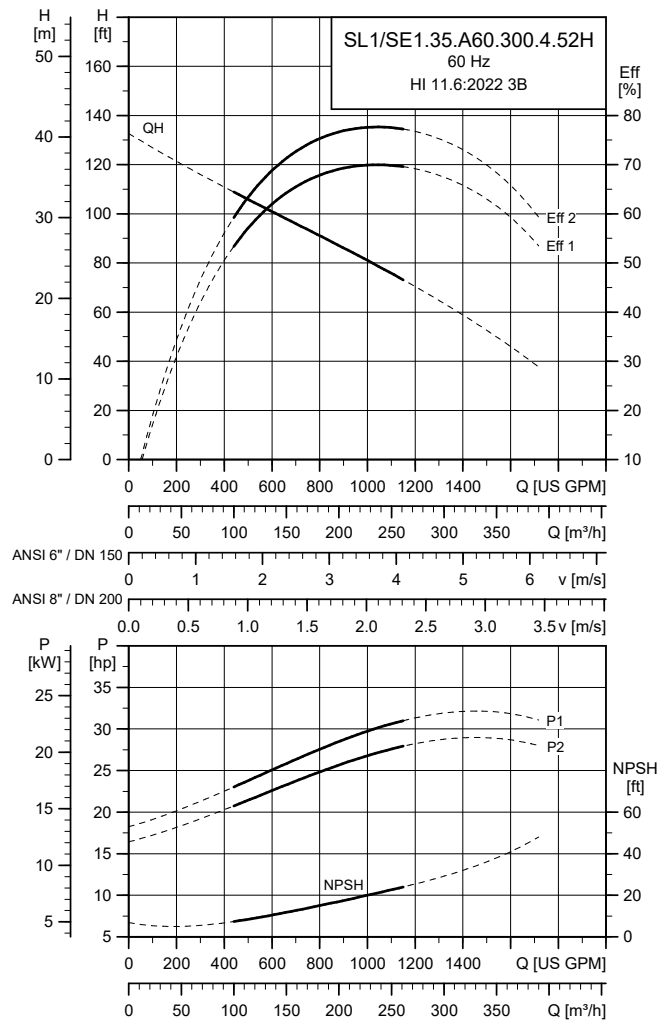

TM054110

Note: Performance grade 3B is the minimum standard to which any pump is tested before shipping from the factory. See, [Variants of customized pumps - Tests](#), for testing options. See, [How to read the performance curves](#).

Electrical data

Pump type	Voltage variant	P1	P2	Number of poles	RPM	Starting method	I_N	I_{start}	η_{motor} [%]			$\cos \phi$			Moment of inertia	Breakdown torque M_{max}
		[hp (kW)]	[hp (kW)]						1/2	3/4	1/1	1/2	3/4	1/1		
SL1/ SE1.35.A60.300.4.52H	60R 3 x 230 V	32.9 (25)	29.5 (22)	4	1779	D	73	534	88	89	90	0.70	0.79	0.84	1.78 (0.0750)	260 (353)
	61G 3 x 380-480/ 660-690 V	32.9 (25)	29.5 (22)	4	1779	Y/D	48-38/ 28-27	379/ 174	88	89	90	0.64	0.73	0.78	1.78 (0.0750)	252 (342)
	61M 3 x 575-600 V	32.9 (25)	29.5 (22)	4	1779	D	30-29	292	88	89	90	0.68	0.77	0.82	1.78 (0.0750)	320 (434)

Pump data

Pump type	Impeller diameter	Max. solids size	Outlet flange pressure (according to ASME B 16.5)	Max. installation depth
	[in. (mm)]	[in. (mm)]	[PSI (PN)]	[ft (m)]
SL1/SE1.35.A60.300.4.52H	11 (281)	3.5 (85)	145 (10)	66 (20)

Note: Pumps with stainless steel closed S-tube[®] impellers have the same performance curves as the corresponding cast iron versions.

SL1/SE1.35.A60.330.4.52H

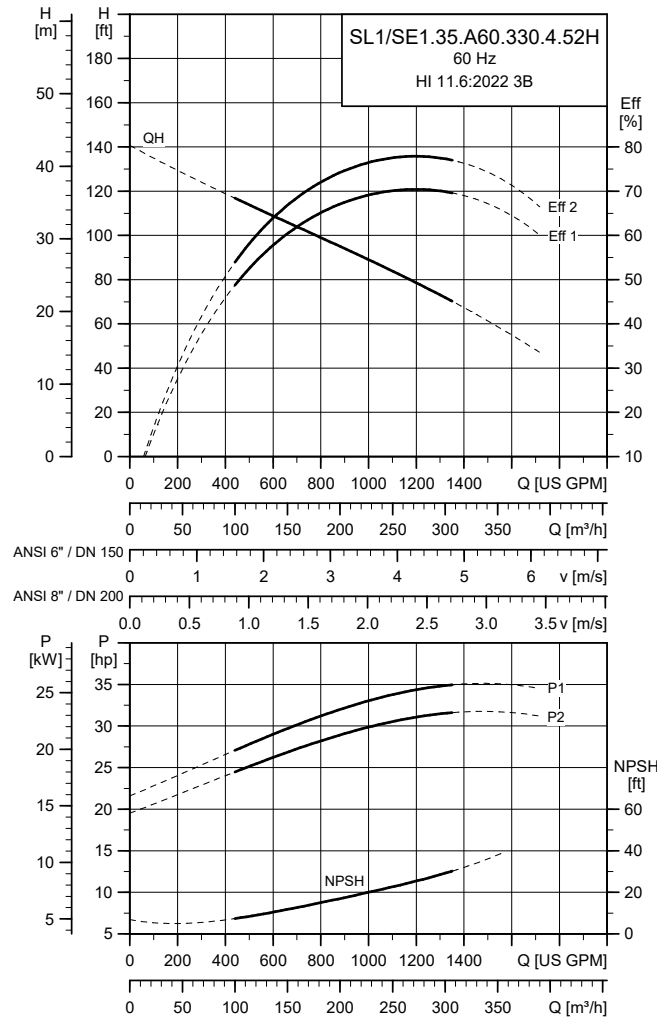

TM054111

Note: Performance grade 3B is the minimum standard to which any pump is tested before shipping from the factory. See, [Variants of customized pumps - Tests](#), for testing options. See, [How to read the performance curves](#).

Electrical data

Pump type	Voltage variant	P1 [hp (kW)]	P2 [hp (kW)]	Number of poles	RPM	Starting method	I _N [A]	I _{start} [A]	η _{motor} [%]			Cos φ			Moment of inertia [lbft ² (kgm ²)]	Breakdown torque M _{max} [lb*ft (Nm)]
									1/2	3/4	1/1	1/2	3/4	1/1		
SL1/ SE1.35.A60.330.4.52H	60R 3 x 230 V	36.5 (27)	32.9 (24.5)	4	1777	D	80	534	88	89	90	0.72	0.81	0.86	1.78 (0.0750)	260 (353)
	61G 3 x 380-480/ 660-690 V	36.5 (27)	32.9 (24.5)	4	1777	Y/D	52-41/ 30-29	379/ 174	88	89	90	0.66	0.75	0.80	1.78 (0.0750)	252 (342)
	61M 3 x 575-600 V	36.5 (27)	32.9 (24.5)	4	1777	D	33-32	292	88	89	90	0.70	0.79	0.84	1.78 (0.0750)	320 (434)

Pump data

Pump type	Impeller diameter	Max. solids size	Outlet flange pressure (according to ASME B 16.5)	Max. installation depth
	[in. (mm)]	[in. (mm)]	[PSI (PN)]	[ft (m)]
SL1/SE1.35.A60.330.4.52H	11.5 (292)	3.5 (85)	145 (10)	66 (20)

Note: Pumps with stainless steel closed S-tube[®] impellers have the same performance curves as the corresponding cast iron versions.

SL1/SE1.40.A80.120.4.52M

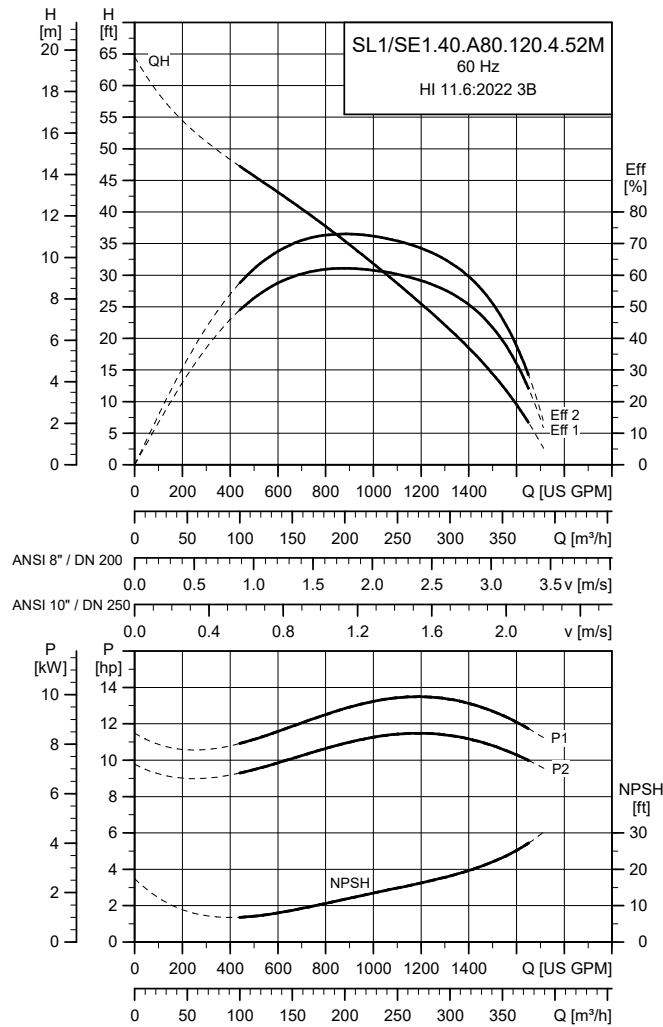

TM1064276

Note: Performance grade 3B is the minimum standard to which any pump is tested before shipping from the factory. See, [Variants of customized pumps - Tests](#), for testing options. See, [How to read the performance curves](#).

Electrical data

Pump type	Voltage variant	P1	P2	Number of poles	RPM	Starting method	I_N			$\eta_{\text{motor}} [\%]$			$\text{Cos } \varphi$			Moment of inertia [lbft ² (kgm ²)]	Breakdown torque M_{max} [lbft ² (Nm)]
		[hp (kW)]	[hp (kW)]				[A]	[A]	1/2	3/4	1/1	1/2	3/4	1/1			
SL1/ SE1.40.A80.120.4.52M	60S 3 x 208 V	13.8 (10)	12.1 (9)	4	1785	D	37	332	82	85	88	0.68	0.73	0.78	1.38 (0.0580)	166 (225)	
	61R 3 x 230/460 V	13.8 (10)	12.1 (9)	4	1785	Y/D	32/16	279/ 192	82	85	88	0.72	0.77	0.82	1.38 (0.0580)	121 (164)	
	61M 3 x 575-600 V	13.8 (10)	12.1 (9)	4	1785	D	14-13	155	82	85	88	0.69	0.74	0.79	1.38 (0.0580)	179 (243)	

Pump data

Pump type	Impeller diameter	Max. solids size	Outlet flange pressure (according to ASME B 16.5)	Max. installation depth
	[in. (mm)]	[in. (mm)]	[PSI (PN)]	[ft (m)]
SL1/SE1.40.A80.120.4.52M	8.5 (215)	4.0 (105)	145 (10)	66 (20)

Note: Pumps with stainless steel closed S-tube[®] impellers have the same performance curves as the corresponding cast iron versions.

SL1/SE1.40.A80.150.4.52M

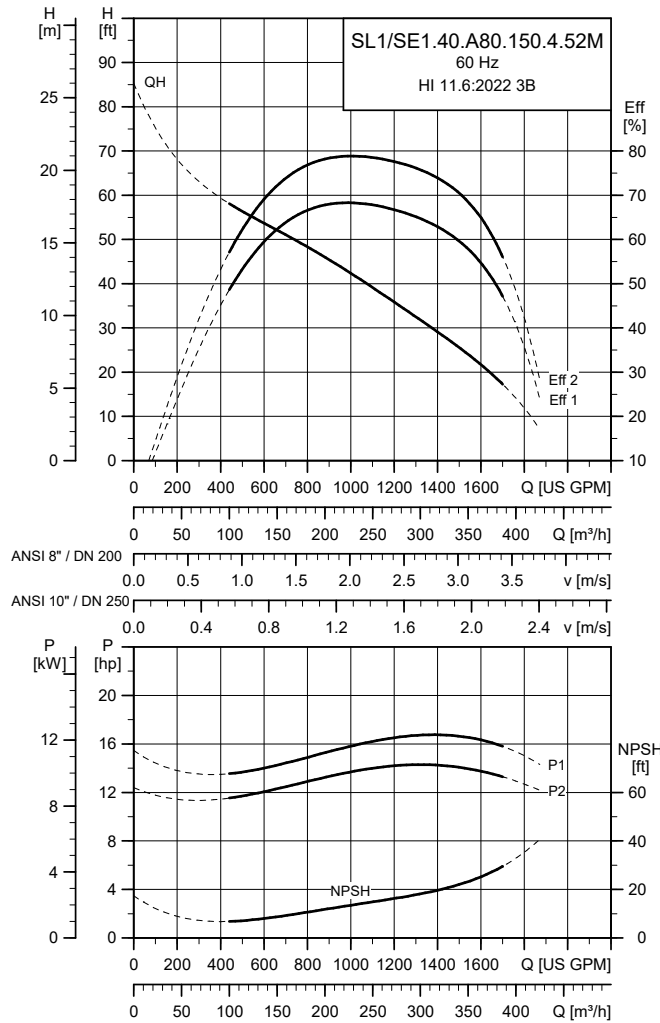

TM064277

Note: Performance grade 3B is the minimum standard to which any pump is tested before shipping from the factory. See, [Variants of customized pumps - Tests](#), for testing options. See, [How to read the performance curves](#).

Electrical data

Pump type	Voltage variant	P1	P2	Number of poles	RPM	Starting method	I _N			η _{motor} [%]			Cos φ			Moment of inertia [lbft ² (kgm ²)]	Breakdown torque M _{max} [lbft ² (Nm)]
		[hp (kW)]	[hp (kW)]				[A]	[A]	1/2	3/4	1/1	1/2	3/4	1/1			
SL1/ SE1.40.A80.150.4.52M	60S 3 x 208 V	16.6 (12)	14.8 (11)	4	1782	D	43	332	84	87	89	0.70	0.76	0.82	1.38 (0.0580)	166 (225)	
	61R 3 x 230/460 V	16.6 (12)	14.8 (11)	4	1782	Y/D	37/19	279/192	84	87	89	0.74	0.80	0.86	1.38 (0.0580)	121 (164)	
	61M 3 x 575-600 V	16.6 (12)	14.8 (11)	4	1782	D	16-15	155	84	87	89	0.71	0.77	0.83	1.38 (0.0580)	179 (243)	

Pump data

Pump type	Impeller diameter	Max. solids size	Outlet flange pressure (according to ASME B 16.5)	Max. installation depth
	[in. (mm)]	[in. (mm)]	[PSI (PN)]	[ft (m)]
SL1/SE1.40.A80.150.4.52M	9.0 (228)	4.0 (105)	145 (10)	66 (20)

Note: Pumps with stainless steel closed S-tube[®] impellers have the same performance curves as the corresponding cast iron versions.

SL1/SE1.40.A80.175.4.52M

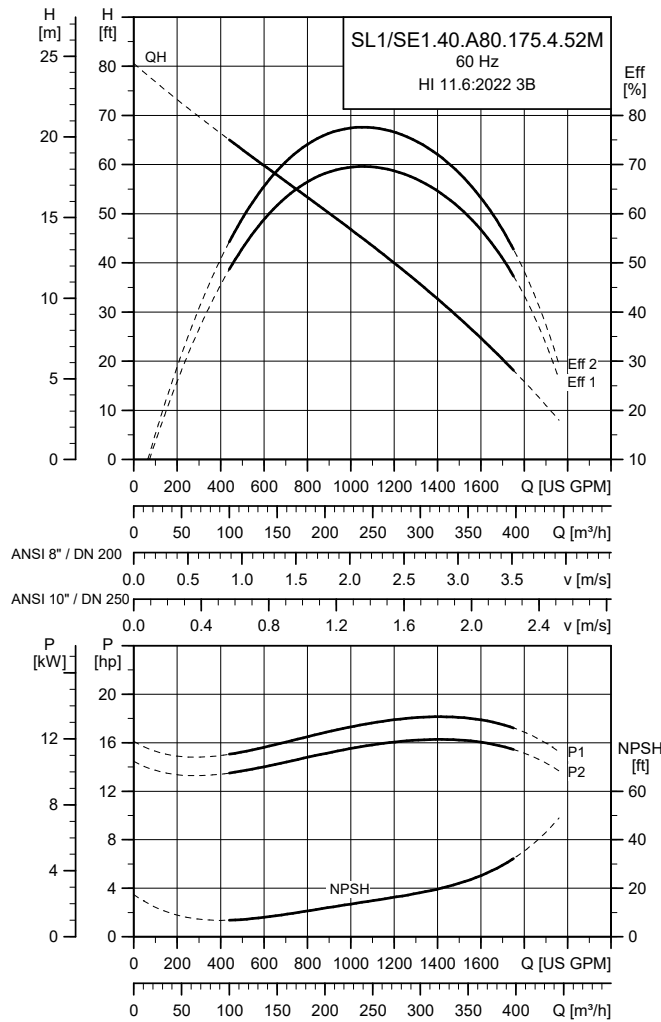

TM064278

Note: Performance grade 3B is the minimum standard to which any pump is tested before shipping from the factory. See, [Variants of customized pumps - Tests](#), for testing options. See, [How to read the performance curves](#).

Electrical data

Pump type	Voltage variant	P1 [hp (kW)]	P2 [hp (kW)]	Number of poles	RPM	Starting method	I_N			η_{motor} [%]			Cos ϕ			Moment of inertia [lbf ² (kgm ²)]	Breakdown torque M_{max} [lbf ² (Nm)]
							[A]	[A]	1/2	3/4	1/1	1/2	3/4	1/1			
SL1/ SE1.40.A80.175.4.52M	60S 3 x 208 V	19.3 (14)	17.4 (13)	4	1785	D	50	420	86	89	90	0.64	0.75	0.81	1.78 (0.0750)	260 (353)	
	61R 3 x 230/460 V	19.3 (14)	17.4 (13)	4	1785	Y/D	44/22	420/ 290	86	89	90	0.66	0.77	0.83	1.78 (0.0750)	184 (249)	
	61M 3 x 575-600 V	19.3 (14)	17.4 (13)	4	1785	D	18-17	207	86	89	90	0.66	0.77	0.83	1.78 (0.0750)	144 (195)	

Pump data

Pump type	Impeller diameter	Max. solids size	Outlet flange pressure (according to ASME B 16.5)	Max. installation depth
	[in. (mm)]	[in. (mm)]	[PSI (PN)]	[ft (m)]
SL1/SE1.40.A80.175.4.52M	9.2 (233)	4.0 (105)	145 (10)	66 (20)

Note: Pumps with stainless steel closed S-tube[®] impellers have the same performance curves as the corresponding cast iron versions.

SL1/SE1.40.A80.200.4.52M

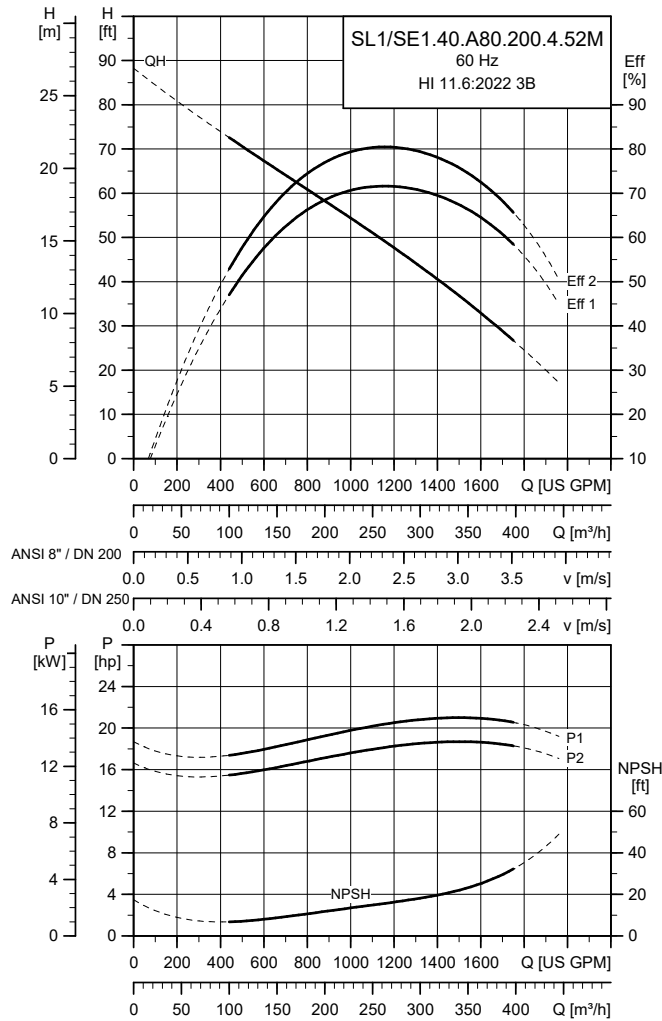

TM064279

Note: Performance grade 3B is the minimum standard to which any pump is tested before shipping from the factory. See, [Variants of customized pumps - Tests](#), for testing options. See, [How to read the performance curves](#).

Electrical data

Pump type	Voltage variant	P1	P2	Number of poles	RPM	Starting method	I _N			η _{motor} [%]			Cos φ			Moment of inertia [lbft ² (kgm ²)]	Breakdown torque M _{max} [lbft ² (Nm)]
		[hp (kW)]	[hp (kW)]				[A]	[A]	1/2	3/4	1/1	1/2	3/4	1/1			
SL1/SE1.40.A80.200.4.52M	60S 3 x 208 V	22.3 (17)	20.1 (15)	4	1783	D	57	420	87	90	90	0.68	0.78	0.82	1.78 (0.0750)	260 (353)	
	61R 3 x 230/460 V	22.3 (17)	20.1 (15)	4	1783	Y/D	50/25	420/290	87	90	90	0.70	0.80	0.84	1.78 (0.0750)	184 (249)	
	61M 3 x 575-600 V	22.3 (17)	20.1 (15)	4	1783	D	20-20	207	87	90	90	0.70	0.80	0.84	1.78 (0.0750)	144 (195)	

Pump data

Pump type	Impeller diameter	Max. solids size	Outlet flange pressure (according to ASME B 16.5)	Max. installation depth
	[in. (mm)]	[in. (mm)]	[PSI (PN)]	[ft (m)]
SL1/SE1.40.A80.200.4.52M	9.5 (241)	4.0 (105)	145 (10)	66 (20)

Note: Pumps with stainless steel closed S-tube[®] impellers have the same performance curves as the corresponding cast iron versions.

SL1/SE1.45.A80.245.4.52M

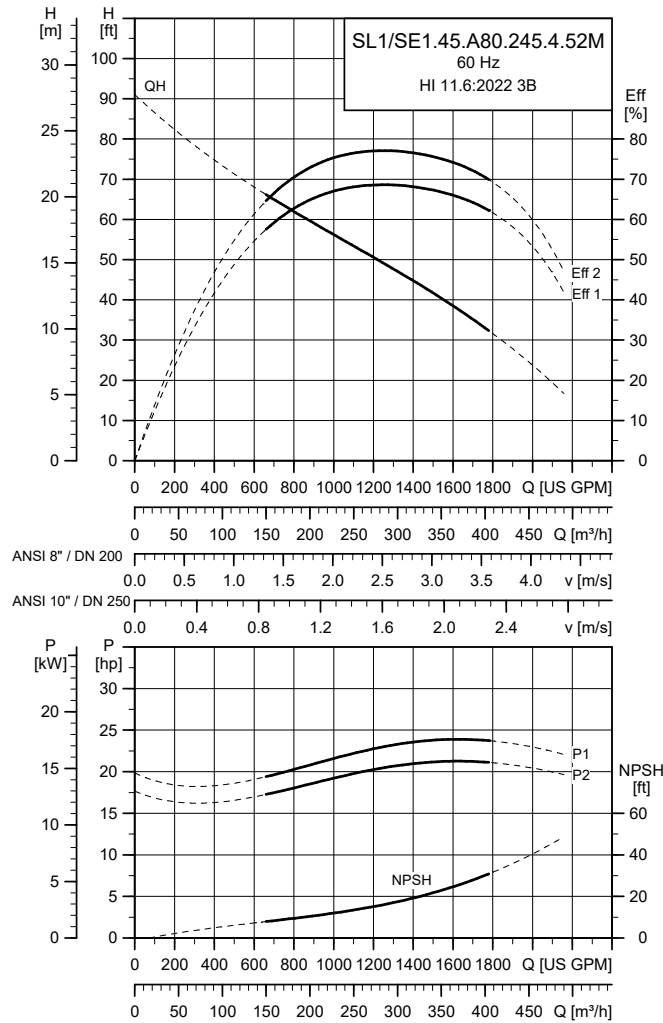

TM054112

Note: Performance grade 3B is the minimum standard to which any pump is tested before shipping from the factory. See, [Variants of customized pumps - Tests](#), for testing options. See, [How to read the performance curves](#).

Electrical data

Pump type	Voltage variant	P1	P2	Number of poles	RPM	Starting method	I _N		η _{motor} [%]			Cos φ			Moment of inertia [lbf ² (kgm ²)]	Breakdown torque M _{max} [lbf ² (Nm)]
		[hp (kW)]	[hp (kW)]				[A]	[A]	1/2	3/4	1/1	1/2	3/4	1/1		
SL1/ SE1.45.A80.245.4.52M	60S 3 x 208 V	27.1 (20)	24.1 (18)	4	1783	D	70	830	87	88	89	0.66	0.74	0.81	1.78 (0.0750)	371 (503)
	61R 3 x 230/460 V	27.1 (20)	24.1 (18)	4	1783	Y/D	64/32	534/ 363	87	88	89	0.66	0.74	0.81	1.78 (0.0750)	260 (353)
	61M 3 x 575-600 V	27.1 (20)	24.1 (18)	4	1783	D	26-25	292	87	88	89	0.64	0.72	0.79	1.78 (0.0750)	320 (434)

Pump data

Pump type	Impeller diameter	Max. solids size	Outlet flange pressure (according to ASME B 16.5)	Max. installation depth
	[in. (mm)]	[in. (mm)]	[PSI (PN)]	[ft (m)]
SL1/SE1.45.A80.245.4.52M	9.7 (246)	4.5 (110)	145 (10)	66 (20)

Note: Pumps with stainless steel closed S-tube[®] impellers have the same performance curves as the corresponding cast iron versions.

SL1/SE1.45.A80.270.4.52M

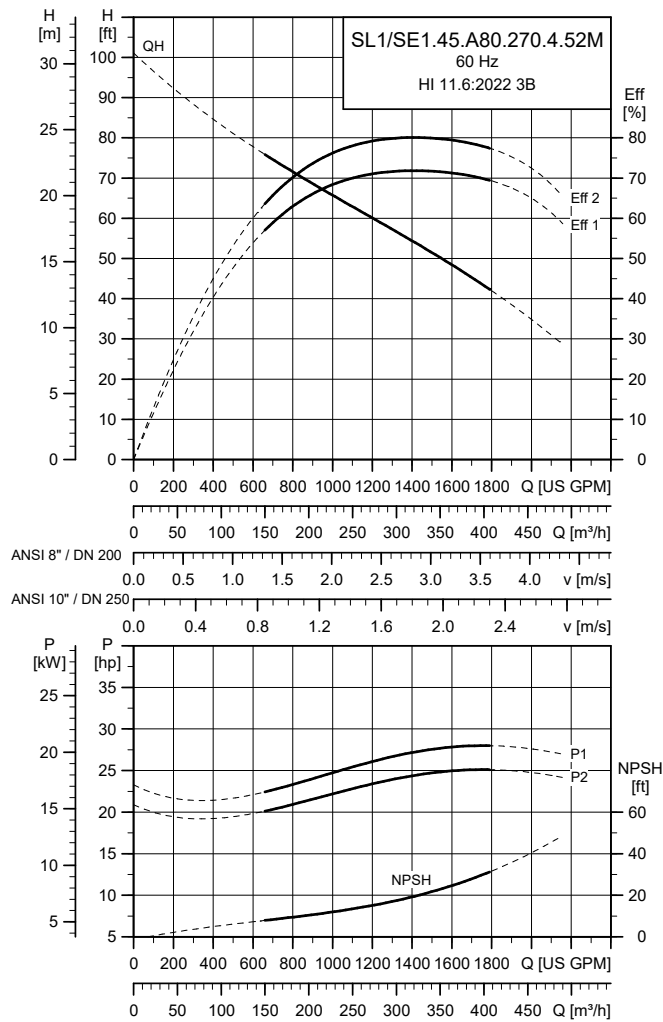

TM054113

Note: Performance grade 3B is the minimum standard to which any pump is tested before shipping from the factory. See, [Variants of customized pumps - Tests](#), for testing options. See, [How to read the performance curves](#).

Electrical data

Pump type	Voltage variant	P1	P2	Number of poles	RPM	Starting method	I _N [A]	I _{start} [A]	η _{motor} [%]			Cos φ			Moment of inertia [lbft ² (kgm ²)]	Breakdown torque M _{max} [lb*ft (Nm)]
		[hp (kW)]	[hp (kW)]						1/2	3/4	1/1	1/2	3/4	1/1		
SL1/ SE1.45.A80.270.4.52M	60S 3 x 208 V	30.0 (22)	26.8 (20)	4	1782	D	76	830	88	88	89	0.68	0.77	0.83	1.78 (0.0750)	371 (503)
	61R 3 x 230/460 V	30.0 (22)	26.8 (20)	4	1782	Y/D	68/34	534/363	88	88	89	0.68	0.77	0.83	1.78 (0.0750)	260 (353)
	61M 3 x 575-600 V	30.0 (22)	26.8 (20)	4	1782	D	28-27	292	88	88	89	0.66	0.75	0.81	1.78 (0.0750)	320 (434)

Pump data

Pump type	Impeller diameter	Max. solids size	Outlet flange pressure (according to ASME B 16.5)	Max. installation depth
	[in. (mm)]	[in. (mm)]	[PSI (PN)]	[ft (m)]
SL1/SE1.45.A80.270.4.52M	10.1 (257)	4.5 (110)	145 (10)	66 (20)

Note: Pumps with stainless steel closed S-tube® impellers have the same performance curves as the corresponding cast iron versions.

SL1/SE1.45.A80.300.4.52M

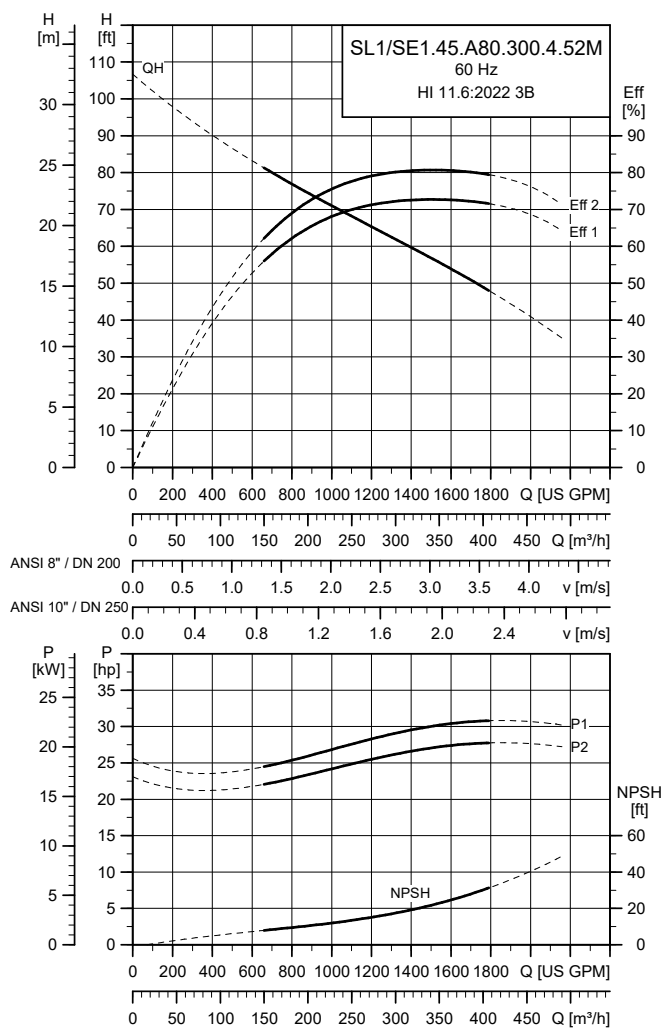

TM054114

Note: Performance grade 3B is the minimum standard to which any pump is tested before shipping from the factory. See, [Variants of customized pumps - Tests](#), for testing options. See, [How to read the performance curves](#).

Electrical data

Pump type	Voltage variant	P1	P2	Number of poles	RPM	Starting method	I _N		η _{motor} [%]			Cos φ			Moment of inertia [lbf ² (kgm ²)]	Breakdown torque M _{max} [lbf*ft (Nm)]
		[hp (kW)]	[hp (kW)]				[A]	[A]	1/2	3/4	1/1	1/2	3/4	1/1		
SL1/ SE1.45.A80.300.4.52M	60R 3 x 230 V	32.9 (25)	29.5 (22)	4	1779	D	73	534	88	89	90	0.70	0.79	0.84	1.78 (0.0750)	260 (353)
	61G 3 x 380-480/ 660-690 V	32.9 (25)	29.5 (22)	4	1779	Y/D	48-38/ 28-27	379/ 174	88	89	90	0.64	0.73	0.78	1.78 (0.0750)	252 (342)
	61M 3 x 575-600 V	32.9 (25)	29.5 (22)	4	1779	D	30-29	292	88	89	90	0.68	0.77	0.82	1.78 (0.0750)	320 (434)

Pump data

Pump type	Impeller diameter	Max. solids size	Outlet flange pressure (according to ASME B 16.5)	Max. installation depth
	[in. (mm)]	[in. (mm)]	[PSI (PN)]	[ft (m)]
SL1/SE1.45.A80.300.4.52M	10.4 (264)	4.5 (110)	145 (10)	66 (20)

Note: Pumps with stainless steel closed S-tube[®] impellers have the same performance curves as the corresponding cast iron versions.

SL1/SE1.45.A80.330.4.52M

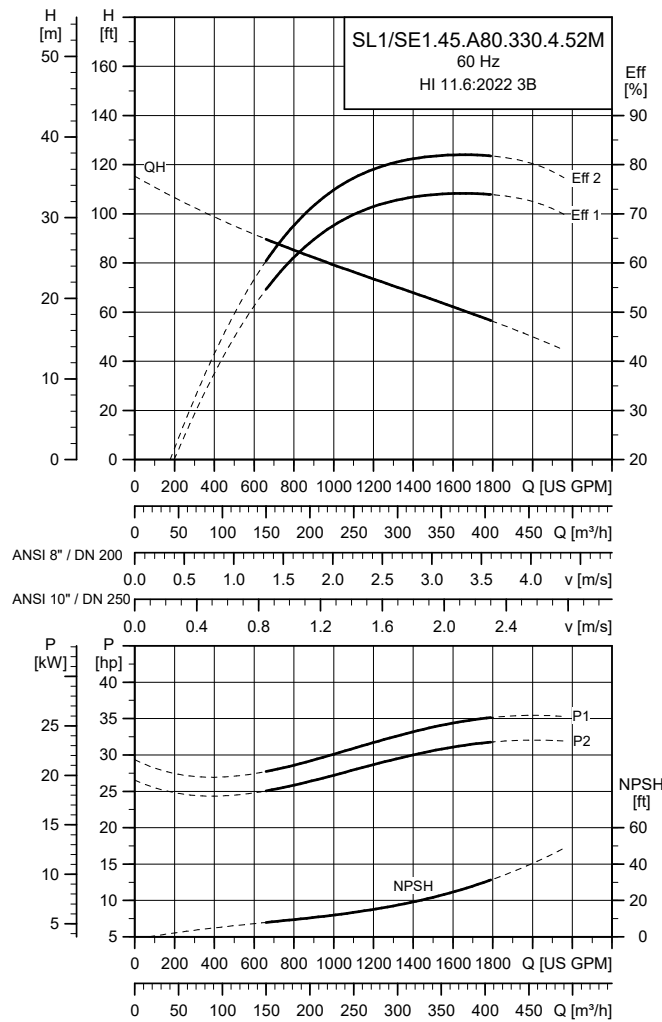

TM054115

Note: Performance grade 3B is the minimum standard to which any pump is tested before shipping from the factory. See, [Variants of customized pumps - Tests](#), for testing options. See, [How to read the performance curves](#).

Electrical data

Pump type	Voltage variant	P1	P2	Number of poles	RPM	Starting method	I _N		η _{motor} [%]			Cos φ			Moment of inertia [lbft ² (kgm ²)]	Breakdown torque M _{max} [lb*ft (Nm)]
		[hp (kW)]	[hp (kW)]				[A]	[A]	1/2	3/4	1/1	1/2	3/4	1/1		
SL1/ SE1.45.A80.330.4.52M	60R 3 x 230 V	36.5 (27)	32.9 (24.5)	4	1776	D	80	534	88	89	90	0.72	0.81	0.86	1.78 (0.0750)	260 (353)
	61G 3 x 380-480/ 660-690 V	36.5 (27)	32.9 (24.5)	4	1776	Y/D	52-41/ 30-29	379/ 174	88	89	90	0.66	0.75	0.80	1.78 (0.0750)	252 (342)
	61M 3 x 575-600 V	36.5 (27)	32.9 (24.5)	4	1776	D	33-32	292	88	89	90	0.70	0.79	0.84	1.78 (0.0750)	320 (434)

Pump data

Pump type	Impeller diameter	Max. solids size	Outlet flange pressure (according to ASME B 16.5)	Max. installation depth
	[in. (mm)]	[in. (mm)]	[PSI (PN)]	[ft (m)]
SL1/SE1.45.A80.330.4.52M	10.7 (273)	4.5 (110)	145 (10)	66 (20)

Note: Pumps with stainless steel closed S-tube[®] impellers have the same performance curves as the corresponding cast iron versions.

SL2/SE2.45.A100.150.4.52L

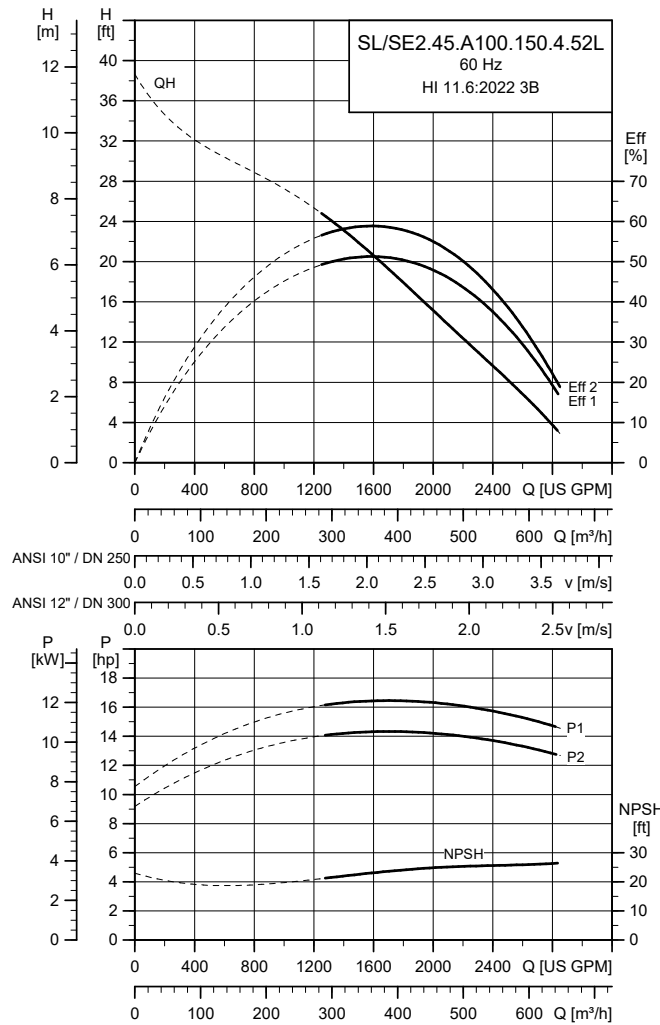

TM070163

Note: Performance grade 3B is the minimum standard to which any pump is tested before shipping from the factory. See, [Variants of customized pumps - Tests](#), for testing options. See, [How to read the performance curves](#).

Electrical data

Pump type	Voltage variant	P1	P2	Number of poles	RPM	Starting method	I_N			$\eta_{\text{motor}} [\%]$			$\text{Cos } \varphi$			Moment of inertia [lbft ² (kgm ²)]	Breakdown torque M_{max} [lbft ² (Nm)]
		[hp (kW)]	[hp (kW)]				[A]	[A]	[A]	1/2	3/4	1/1	1/2	3/4	1/1		
SL/ SE2.45.A100.150.4.52L	60S 3 x 208 V	16.6 (12)	14.8 (11)	4	1782	D	43	332	84	87	89	0.70	0.76	0.82	1.38 (0.0580)	166 (225)	
	61R 3 x 230/460 V	16.6 (12)	14.8 (11)	4	1782	Y/D	37/19	279/ 192	84	87	89	0.74	0.80	0.86	1.38 (0.0580)	121 (164)	
	61M 3 x 575-600 V	16.6 (12)	14.8 (11)	4	1782	D	16-15	155	84	87	89	0.71	0.77	0.83	1.38 (0.0580)	179 (243)	

Pump data

Pump type	Impeller diameter	Max. solids size	Outlet flange pressure (according to ASME B 16.5)	Max. installation depth
	[in. (mm)]	[in. (mm)]	[PSI (PN)]	[ft (m)]
SL/SE2.45.A100.150.4.52L	8.0 (203)	4.5 (110)	145 (10)	66 (20)

Note: Pumps with stainless steel closed S-tube[®] impellers have the same performance curves as the corresponding cast iron versions.

SL2/SE2.45.A100.175.4.52L

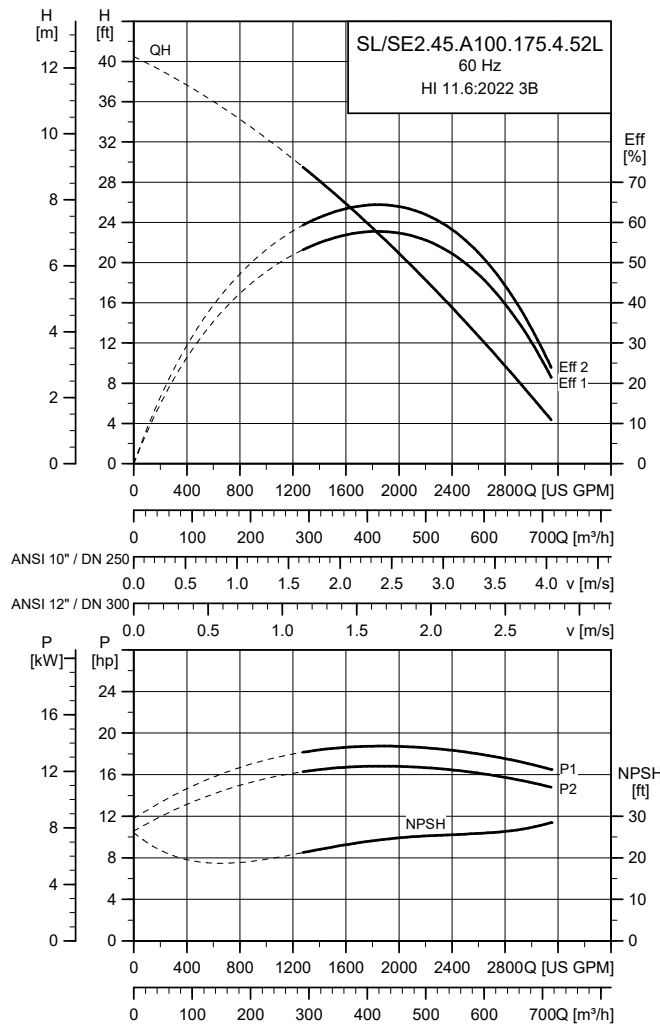

TM070164

Note: Performance grade 3B is the minimum standard to which any pump is tested before shipping from the factory. See, [Variants of customized pumps - Tests](#), for testing options. See, [How to read the performance curves](#).

Electrical data

Pump type	Voltage variant	P1	P2	Number of poles	RPM	Starting method	I _N			η _{motor} [%]			Cos φ			Moment of inertia [lbft ² (kgm ²)]	Breakdown torque M _{max} [lbft ² (Nm)]
		[hp (kW)]	[hp (kW)]				[A]	[A]	1/2	3/4	1/1	1/2	3/4	1/1			
	60S 3 x 208 V	19.3 (14)	17.4 (13)	4	1785	D	50	420	86	89	90	0.64	0.75	0.81	1.78 (0.0750)	260 (353)	
SL/SE2.45.A100.175.4.52L	61R 3 x 230/460 V	19.3 (14)	17.4 (13)	4	1785	Y/D	44/22	420/290	86	89	90	0.66	0.77	0.83	1.78 (0.0750)	184 (249)	
	61M 3 x 575-600 V	19.3 (14)	17.4 (13)	4	1785	D	18-17	207	86	89	90	0.66	0.77	0.83	1.78 (0.0750)	144 (195)	

Pump data

Pump type	Impeller diameter	Max. solids size	Outlet flange pressure (according to ASME B 16.5)	Max. installation depth
	[in. (mm)]	[in. (mm)]	[PSI (PN)]	[ft (m)]
SL/SE2.45.A100.175.4.52L	8.3 (211)	4.5 (110)	145 (10)	66 (20)

Note: Pumps with stainless steel closed S-tube[®] impellers have the same performance curves as the corresponding cast iron versions.

SL2/SE2.45.A100.200.4.52L

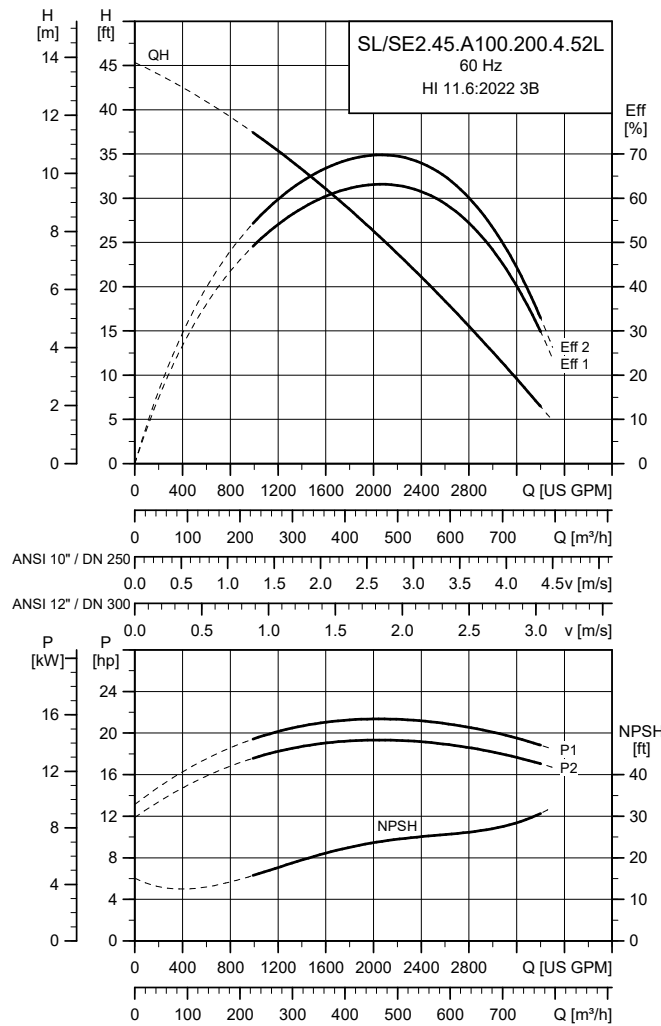

TM070165

Note: Performance grade 3B is the minimum standard to which any pump is tested before shipping from the factory. See, [Variants of customized pumps - Tests](#), for testing options. See, [How to read the performance curves](#).

Electrical data

Pump type	Voltage variant	P1	P2	Number of poles	RPM	Starting method	I_N	I_{start}	η_{motor} [%]			$\cos \phi$			Moment of inertia [lbft ² (kgm ²)]	Breakdown torque M_{max} [lbft ² (Nm)]
		[hp (kW)]	[hp (kW)]						1/2	3/4	1/1	1/2	3/4	1/1		
	60S 3 x 208 V	22.3 (17)	20.1 (15)	4	1783	D	57	420	87	90	90	0.68	0.78	0.82	1.78 (0.0750)	260 (353)
SL/SE2.45.A100.200.4.52L	61R 3 x 230/460 V	22.3 (17)	20.1 (15)	4	1783	Y/D	50/25	420/ 290	87	90	90	0.70	0.80	0.84	1.78 (0.0750)	184 (249)
	61M 3 x 575-600 V	22.3 (17)	20.1 (15)	4	1783	D	20-20	207	87	90	90	0.70	0.80	0.84	1.78 (0.0750)	144 (195)

Pump data

Pump type	Impeller diameter	Max. solids size	Outlet flange pressure (according to ASME B 16.5)	Max. installation depth
	[in. (mm)]	[in. (mm)]	[PSI (PN)]	[ft (m)]
SL/SE2.45.A100.200.4.52L	8.7 (221)	4.5 (110)	145 (10)	66 (20)

Note: Pumps with stainless steel closed S-tube[®] impellers have the same performance curves as the corresponding cast iron versions.

SL2/SE2.45.A100.245.4.52L

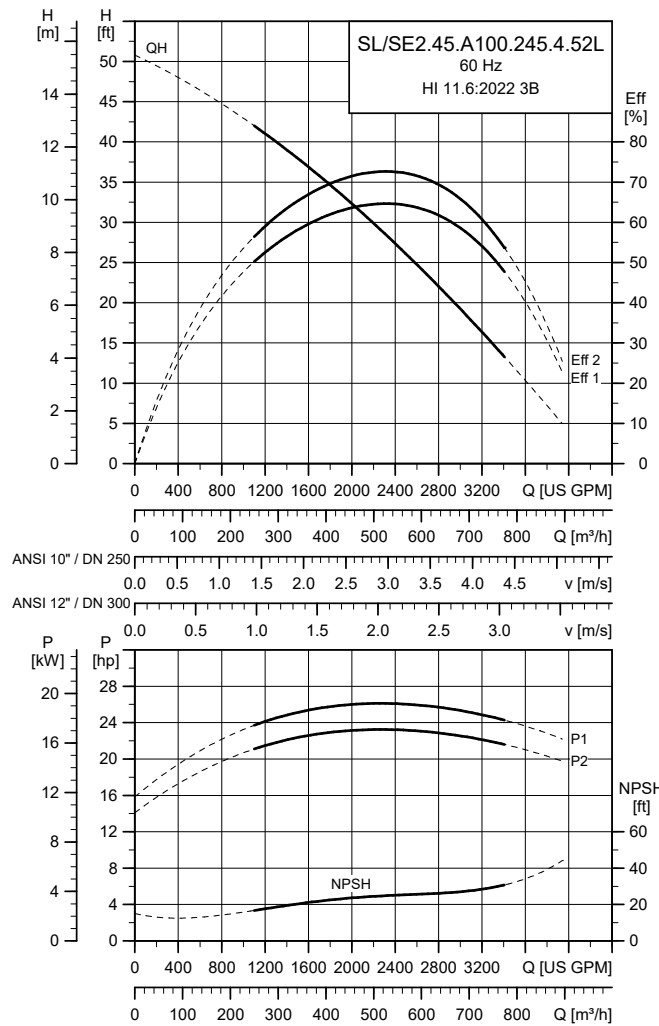

TM070166

Note: Performance grade 3B is the minimum standard to which any pump is tested before shipping from the factory. See, [Variants of customized pumps - Tests](#), for testing options. See, [How to read the performance curves](#).

Electrical data

Pump type	Voltage variant	P1	P2	Number of poles	RPM	Starting method	I _N			η _{motor} [%]			Cos φ			Moment of inertia [lbft² (kgm²)]	Breakdown torque M _{max} [lb*ft (Nm)]
		[hp (kW)]	[hp (kW)]				[A]	[A]	[A]	1/2	3/4	1/1	1/2	3/4	1/1		
	60S 3 x 208 V	27.1 (20)	24.1 (18)	4	1783	D	70	830	87	88	89	0.66	0.74	0.81	1.78 (0.0750)	371 (503)	
SL/SE2.45.A100.245.4.52L	61R 3 x 230/460 V	27.1 (20)	24.1 (18)	4	1783	Y/D	64/32	534/363	87	88	89	0.66	0.74	0.81	1.78 (0.0750)	260 (353)	
	61M 3 x 575-600 V	27.1 (20)	24.1 (18)	4	1783	D	26-25	292	87	88	89	0.64	0.72	0.79	1.78 (0.0750)	320 (434)	

Pump data

Pump type	Impeller diameter	Max. solids size	Outlet flange pressure (according to ASME B 16.5)	Max. installation depth
	[in. (mm)]	[in. (mm)]	[PSI (PN)]	[ft (m)]
SL/SE2.45.A100.245.4.52L	9.1 (231)	4.5 (110)	145 (10)	66 (20)

Note: Pumps with stainless steel closed S-tube® impellers have the same performance curves as the corresponding cast iron versions.

SL2/SE2.45.A100.270.4.52L

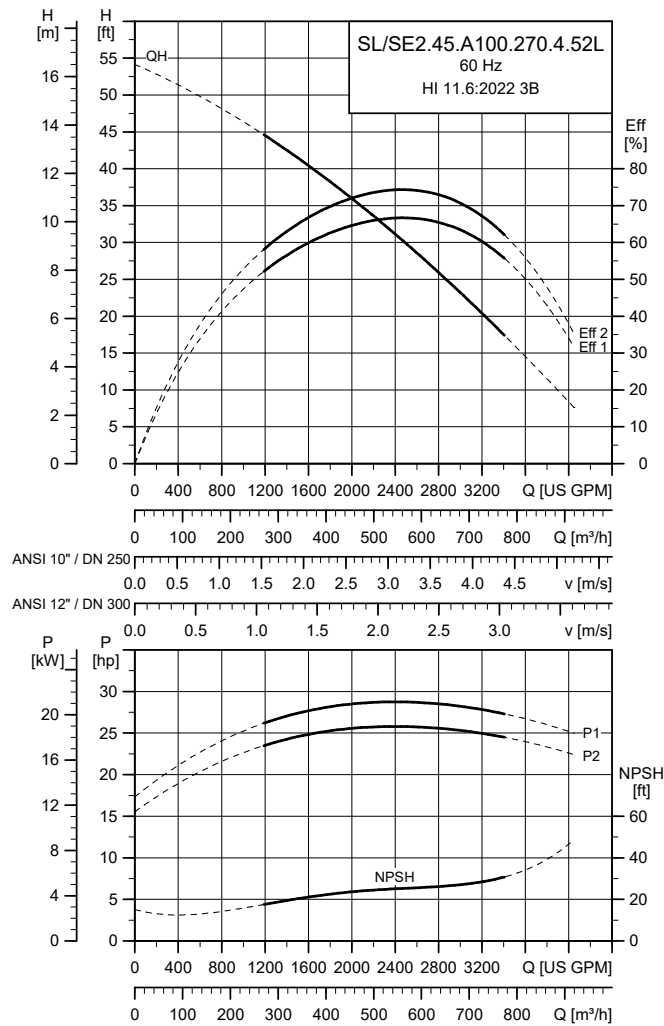

TM070167

Note: Performance grade 3B is the minimum standard to which any pump is tested before shipping from the factory. See, [Variants of customized pumps - Tests](#), for testing options. See, [How to read the performance curves](#).

Electrical data

Pump type	Voltage variant	P1	P2	Number of poles	RPM	Starting method	I _N			I _{start}			η _{motor} [%]			Cos φ			Moment of inertia [lbft ² (kgm ²)]	Breakdown torque M _{max} [lbft ² (Nm)]
		[hp (kW)]	[hp (kW)]				[A]	[A]	[A]	1/2	3/4	1/1	1/2	3/4	1/1					
	60S 3 x 208 V	30.0 (22)	26.8 (20)	4	1782	D	76	830	88	88	89	0.68	0.77	0.83	1.78 (0.0750)	371 (503)				
SL/SE2.45.A100.270.4.52L	61R 3 x 230/460 V	30.0 (22)	26.8 (20)	4	1782	Y/D	68/34	534/363	88	88	89	0.68	0.77	0.83	1.78 (0.0750)	260 (353)				
	61M 3 x 575-600 V	30.0 (22)	26.8 (20)	4	1782	D	28-27	292	88	88	89	0.66	0.75	0.81	1.78 (0.0750)	320 (434)				

Pump data

Pump type	Impeller diameter	Max. solids size	Outlet flange pressure (according to ASME B 16.5)	Max. installation depth
	[in. (mm)]	[in. (mm)]	[PSI (PN)]	[ft (m)]
SL/SE2.45.A100.270.4.52L	9.3 (237)	4.5 (110)	145 (10)	66 (20)

Note: Pumps with stainless steel closed S-tube[®] impellers have the same performance curves as the corresponding cast iron versions.

SL2/SE2.45.A100.300.4.52L

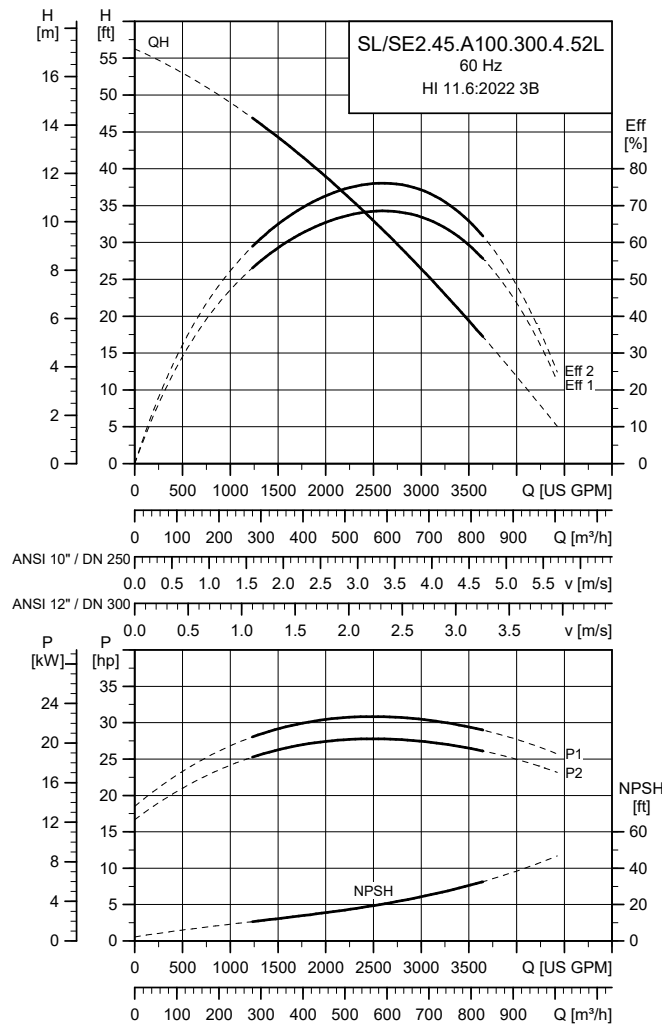

TM070168

Note: Performance grade 3B is the minimum standard to which any pump is tested before shipping from the factory. See, [Variants of customized pumps - Tests](#), for testing options. See, [How to read the performance curves](#).

Electrical data

Pump type	Voltage variant	P1	P2	Number of poles	RPM	Starting method	I _N		η _{motor} [%]			Cos φ			Moment of inertia [lbft ² (kgm ²)]	Breakdown torque M _{max} [lbft ² (Nm)]
		[hp (kW)]	[hp (kW)]				[A]	[A]	1/2	3/4	1/1	1/2	3/4	1/1		
SL/SE2.45.A100.300.4.52L	60R 3 x 230 V	32.9 (25)	29.5 (22)	4	1779	D	73	534	88	89	90	0.70	0.79	0.84	1.78 (0.0750)	260 (353)
	61G 3 x 380-480/660-690 V	32.9 (25)	29.5 (22)	4	1779	Y/D	48-38/28-27	379/174	88	89	90	0.64	0.73	0.78	1.78 (0.0750)	252 (342)
	61M 3 x 575-600 V	32.9 (25)	29.5 (22)	4	1779	D	30-29	292	88	89	90	0.68	0.77	0.82	1.78 (0.0750)	320 (434)

Pump data

Pump type	Impeller diameter	Max. solids size	Outlet flange pressure (according to ASME B 16.5)	Max. installation depth
	[in. (mm)]	[in. (mm)]	[PSI (PN)]	[ft (m)]
SL/SE2.45.A100.300.4.52L	9.4 (240)	4.5 (110)	145 (10)	66 (20)

Note: Pumps with stainless steel closed S-tube[®] impellers have the same performance curves as the corresponding cast iron versions.

SL2/SE2.45.A100.330.4.52L

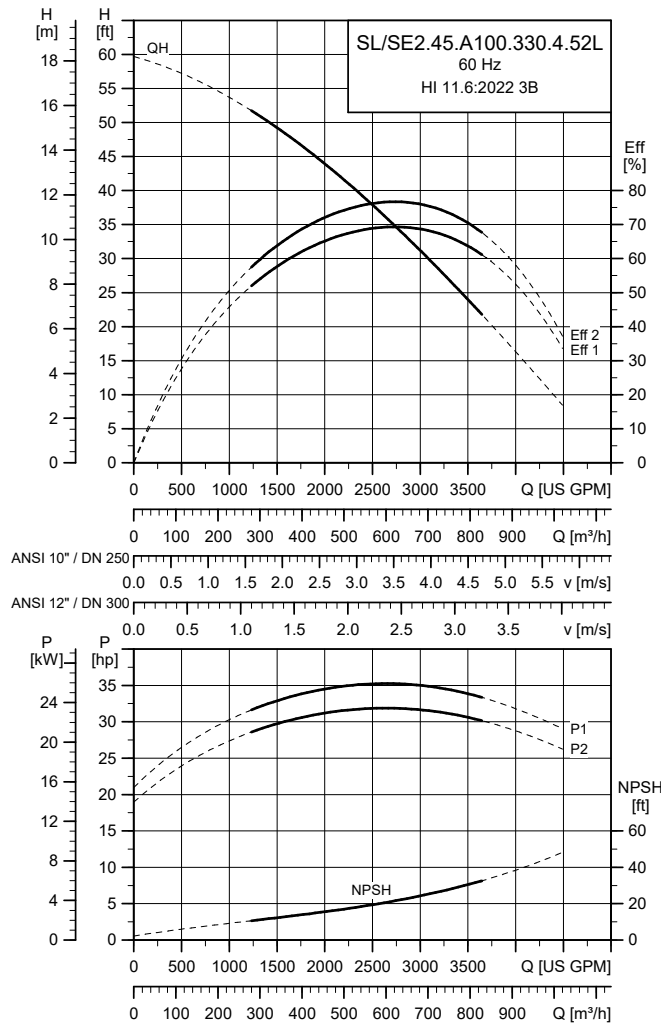

TM070169

Note: Performance grade 3B is the minimum standard to which any pump is tested before shipping from the factory. See, [Variants of customized pumps - Tests](#), for testing options. See, [How to read the performance curves](#).

Electrical data

Pump type	Voltage variant	P1	P2	Number of poles	RPM	Starting method	I_N			$\eta_{\text{motor}} [\%]$			$\text{Cos } \varphi$			Moment of inertia [lbft^2 (kgm^2)]	Breakdown torque M_{max} [lbft^2 (Nm)]
		[hp (kW)]	[hp (kW)]				[A]	[A]	1/2	3/4	1/1	1/2	3/4	1/1			
SL/ SE2.45.A100.330.4.52L	60R 3 x 230 V	36.5 (27)	32.9 (24.5)	4	1776	D	80	534	88	89	90	0.72	0.81	0.86	1.78 (0.0750)	260 (353)	
	61G 3 x 380-480/ 660-690 V	36.5 (27)	32.9 (24.5)	4	1776	Y/D	52-41/ 30-29	379/ 174	88	89	90	0.66	0.75	0.80	1.78 (0.0750)	252 (342)	
	61M 3 x 575-600 V	36.5 (27)	32.9 (24.5)	4	1776	D	33-32	292	88	89	90	0.70	0.79	0.84	1.78 (0.0750)	320 (434)	

Pump data

Pump type	Impeller diameter	Max. solids size	Outlet flange pressure (according to ASME B 16.5)	Max. installation depth
	[in. (mm)]	[in. (mm)]	[PSI (PN)]	[ft (m)]
SL/SE2.45.A100.330.4.52L	9.7 (246)	4.5 (110)	145 (10)	66 (20)

Note: Pumps with stainless steel closed S-tube® impellers have the same performance curves as the corresponding cast iron versions.

SL2/SE2.45.A100.110.6.52E

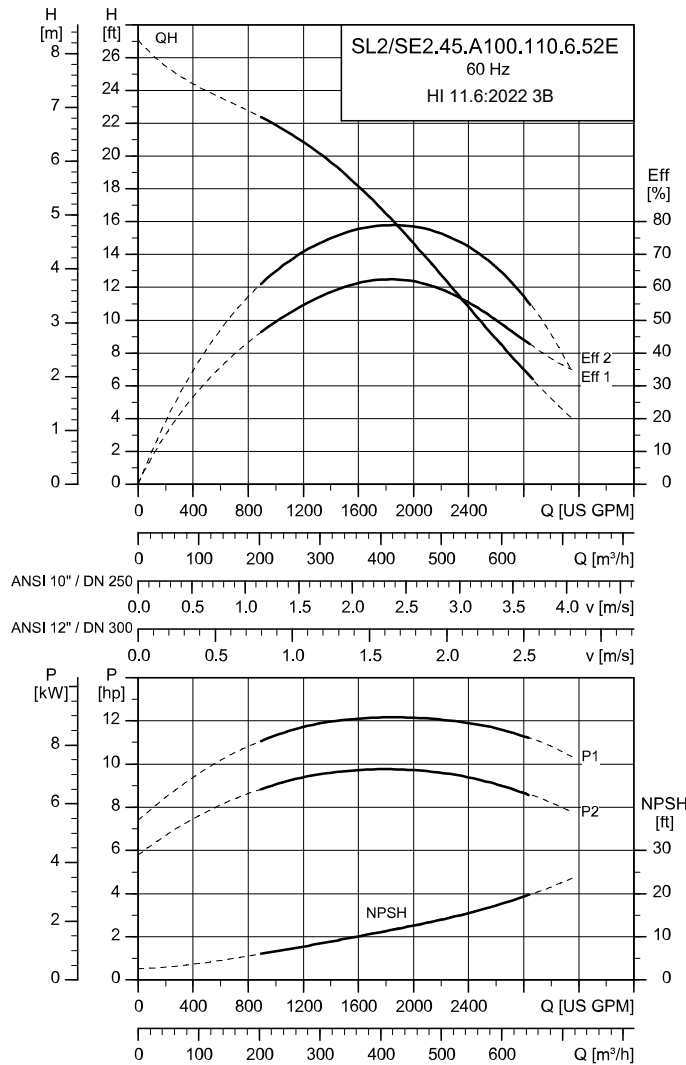

TM069937

Note: Performance grade 3B is the minimum standard to which any pump is tested before shipping from the factory. See Variants of customized pumps section for testing options.

Electrical data

Voltage variant	P1 [hp (kW)]	P2 10.7 (8)	Number of poles	RPM	I _N [A]	I _{start} [A]	η _{motor} [%]			Cos φ			Moment of inertia [lbft ² (kgm ²)]	Breakdown torque M _{max} [lbft ² (Nm)]
							1/2	3/4	1/1	1/2	3/4	1/1		
0S ¹⁴⁾	12.8 (9.5)	10.7 (8)	6	1187	45	*	81	83	84	0.46	0.53	0.60	2.23 (0.0940)	335 (454)
1R ¹⁵⁾	12.2 (9.5)	10.7 (8)	6	1187	31/17	190/128	84/82	86/86	87/87	0.6/0.5	0.7/0.6	0.8/0.7	2.23 (0.0940)	134 (182) / 178 (242)
1M ¹⁶⁾	12.8 (9.5)	10.7 (8)	6	1187	17-16	*	81	82	84	0.42	0.51	0.59	2.23 (0.0940)	335 (454)

¹⁴⁾ 3 x 208D

¹⁵⁾ 3 x 230D/460Y

¹⁶⁾ 3 x 575-600D

Pump data

Impeller diameter	Max. solids size	Outlet flange pressure (according to ASME B 16.5)	Max. installation depth
[in. (mm)]	[in. (mm)]	[PSI (PN)]	[ft (m)]
9.8 (248)	4.5 (110)	145 (10)	66 (20)

Note: Pumps with stainless steel closed S-tube[®] impellers have the same performance curves as the corresponding cast iron versions.

SL2/SE2.45.A100.135.6.52E

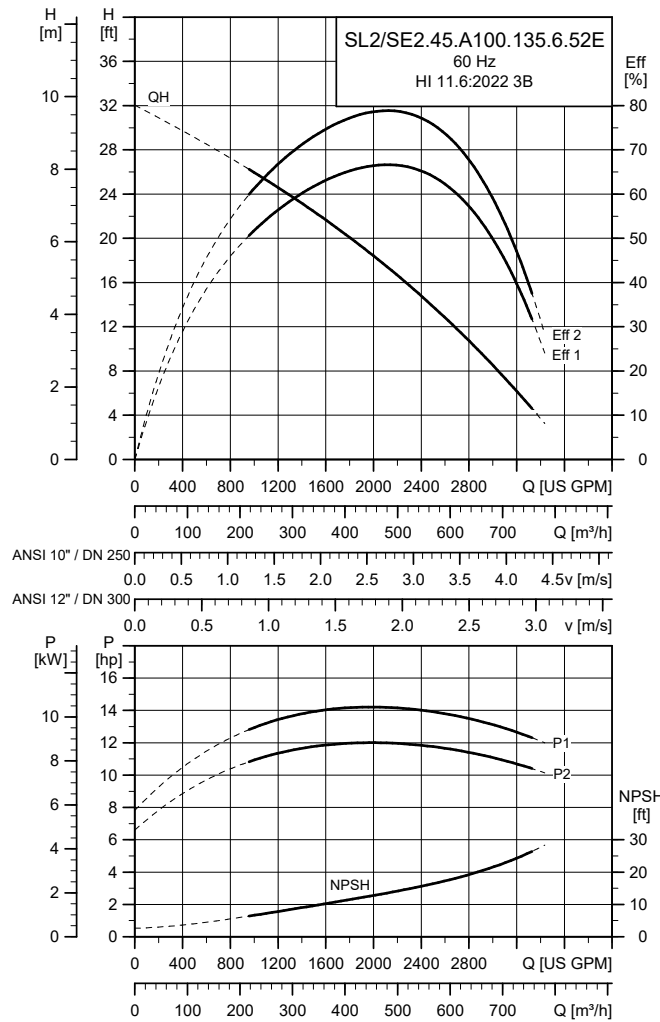

TM069938

Note: Performance grade 3B is the minimum standard to which any pump is tested before shipping from the factory. See, [Variants of customized pumps - Tests](#), for testing options. See, [How to read the performance curves](#).

Electrical data

Voltage variant	P1 [hp (kW)]	P2 [hp (kW)]	Number of poles	RPM	I _N [A]	I _{start} [A]	η _{motor} [%]			Cos φ			Moment of inertia [lbf ² (kgm ²)]	Breakdown torque M _{max} [lbf ² (Nm)]
							1/2	3/4	1/1	1/2	3/4	1/1		
60S ¹⁷⁾	15.8 (11.8)	13.4 (10)	6	1186	51	*	82	84	83	0.50	0.58	0.65	2.23 (0.0940)	335 (454)
61R ¹⁸⁾	15.3 (11.4)	13.4 (10)	6	1186	37/20	190/128	86/84	87/87	88/88	0.7/0.5	0.7/0.7	0.8/0.7	2.23 (0.094)	134 (182) / 178 (242)
61M ¹⁹⁾	15.8 (11.8)	13.4 (10)	6	1186	19-18	*	81	84	85	0.5	0.6	0.7	2.23 (0.094)	335 (454)

¹⁷⁾ 3 x 208D

¹⁸⁾ 3 x 230D/460Y

¹⁹⁾ 3 x 575-600D

Pump data

Impeller diameter	Max. solids size	Outlet flange pressure (according to ASME B 16.5)	Max. installation depth
[in. (mm)]	[in. (mm)]	[PSI (PN)]	[ft (m)]
10.2 (259)	4.5 (110)	145 (10)	66 (20)

Note: Pumps with stainless steel closed S-tube[®] impellers have the same performance curves as the corresponding cast iron versions.

SL2/SE2.45.A100.160.6.52E

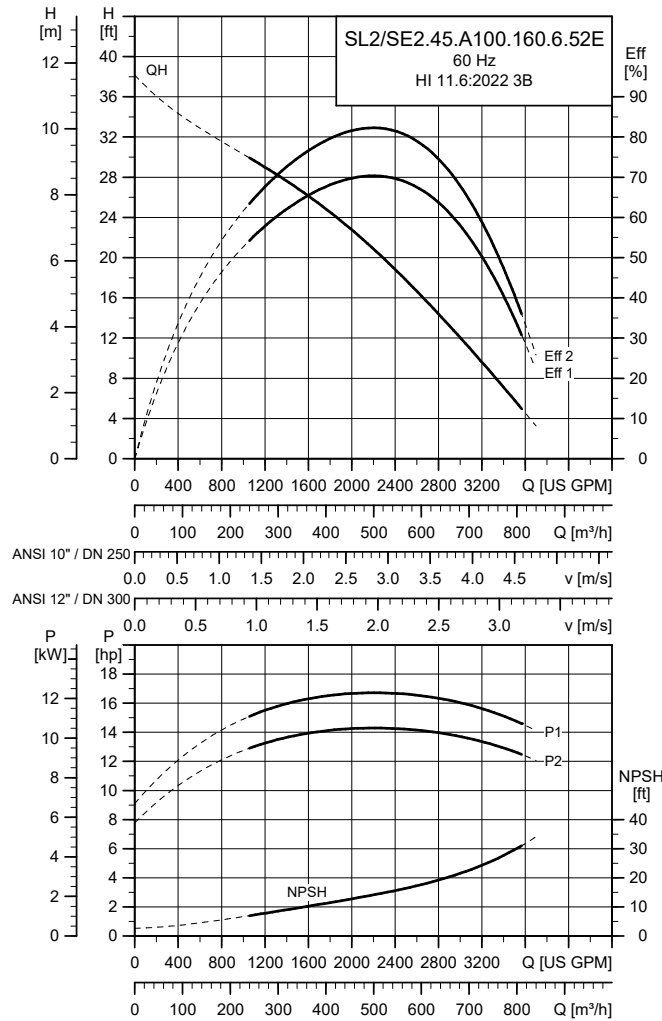

TM069939

Note: Performance grade 3B is the minimum standard to which any pump is tested before shipping from the factory. See, [Variants of customized pumps - Tests](#), for testing options. See, [How to read the performance curves](#).

Electrical data

Voltage variant	P1 [hp (kW)]	P2 [hp (kW)]	Numb er of poles	RPM	I _N [A]	I _{start} [A]	η _{motor} [%]			Cos φ			Moment of inertia [lbf ² (kgm ²)]	Breakdown torque M _{max} [lbf ² ft (Nm)]
							1/2	3/4	1/1	1/2	3/4	1/1		
60S ²⁰⁾	18.9 (14.1)	16.1 (12)	6	1184	56	*	83	84	85	0.53	0.62	0.70	2.23 (0.094)	335 (454)
61R ²¹⁾	18 (13.4)	16.1 (12)	6	1184	46/26	255/176	87/85	88/87	88/88	0.6/0.5	0.7/0.6	0.8/0.7	2.23 (0.094)	181 (246) / 240(325)
61M ²²⁾	18.8 (14)	16.1 (12)	6	1184	20-19	*	82	84	86	0.5	0.6	0.7	2.23 (0.094)	335 (454)

20) 3 x 208D

21) 3 x 230D/460Y

22) 3 x 575-600D

Pump data

Impeller diameter	Max. solids size	Outlet flange pressure (according to ASME B 16.5)	Max. installation depth
[in. (mm)]	[in. (mm)]	[PSI (PN)]	[ft (m)]
10.7 (271)	4.5 (110)	145 (10)	66 (20)

Note: Pumps with stainless steel closed S-tube[®] impellers have the same performance curves as the corresponding cast iron versions.

SL2/SE2.50.A120.190.6.52E

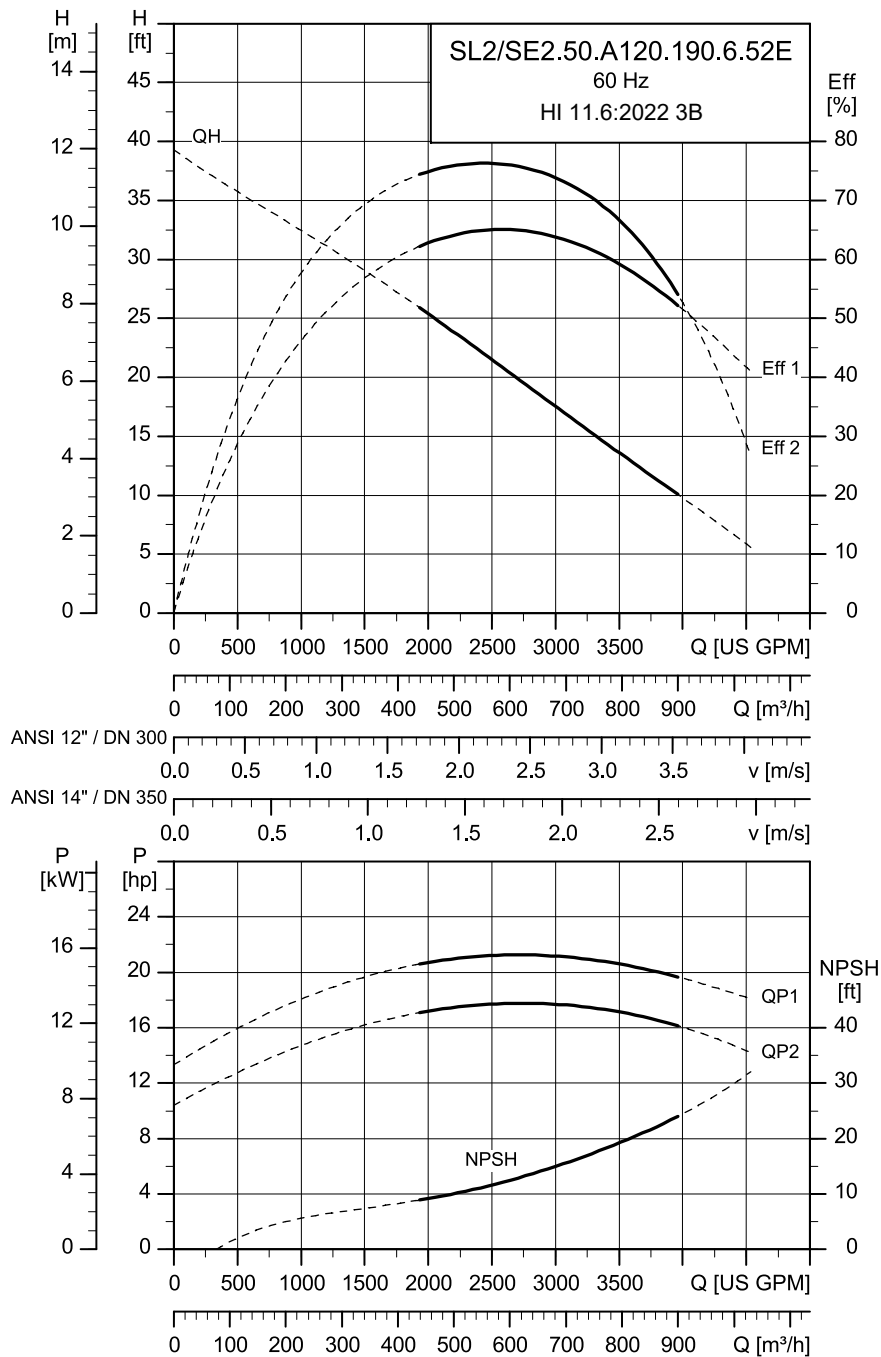

Note: Performance grade 3B is the minimum standard to which any pump is tested before shipping from the factory. See, [Variants of customized pumps - Tests](#), for testing options. See, [How to read the performance curves](#).

Electrical data

Voltage variant	P1 [hp (kW)]	P2 [hp (kW)]	Number of poles	RPM	I _N [A]	I _{start} [A]	η _{motor} [%]			Cos φ			Moment of inertia [lbf·ft² (kgm²)]	Breakdown torque M _{max} [lbf·ft (Nm)]
							1/2	3/4	1/1	1/2	3/4	1/1		
60S ²³⁾	22.0 (16.4)	18.8 (14)	6	1181	62	*	83	85	85	0.6	0.7	0.7	2.23 (0.094)	335 (454)

TM069940

Voltage variant	P1	P2	Number of poles	RPM	I _N [A]	I _{start} [A]	η _{motor} [%]			Cos φ			Moment of inertia [lbf ² (kgm ²)]	Breakdown torque M _{max} [lbf ² ft (Nm)]
	[hp (kW)]	[hp (kW)]					1/2	3/4	1/1	1/2	3/4	1/1		
61R ²⁴⁾	21.2 (15.8)	18.8 (14)	6	1181	52/29	255/176	87/86	88/88	88/89	0.65/0.51	0.7/0.6	0.8/0.7	2.23 (0.094)	181 (246) / 240 (325)
61M ²⁵⁾	21.7 (16.2)	18.8 (14)	6	1181	22-21	*	83	85	86	0.6	0.7	0.8	2.23 (0.094)	335 (454)

23) 3 x 208D

24) 3 x 230D/460Y

25) 3 x 575-600D

Pump data

Impeller diameter	Max. solids size	Outlet flange pressure (according to ASME B 16.5)	Max. installation depth
[in. (mm)]	[in. (mm)]	[PSI (PN)]	[ft (m)]
11.2 (285)	5.0 (125)	145 (10)	66 (20)

Note: Pumps with stainless steel closed S-tube[®] impellers have the same performance curves as the corresponding cast iron versions.

SL2/SE2.50.A120.215.6.52E

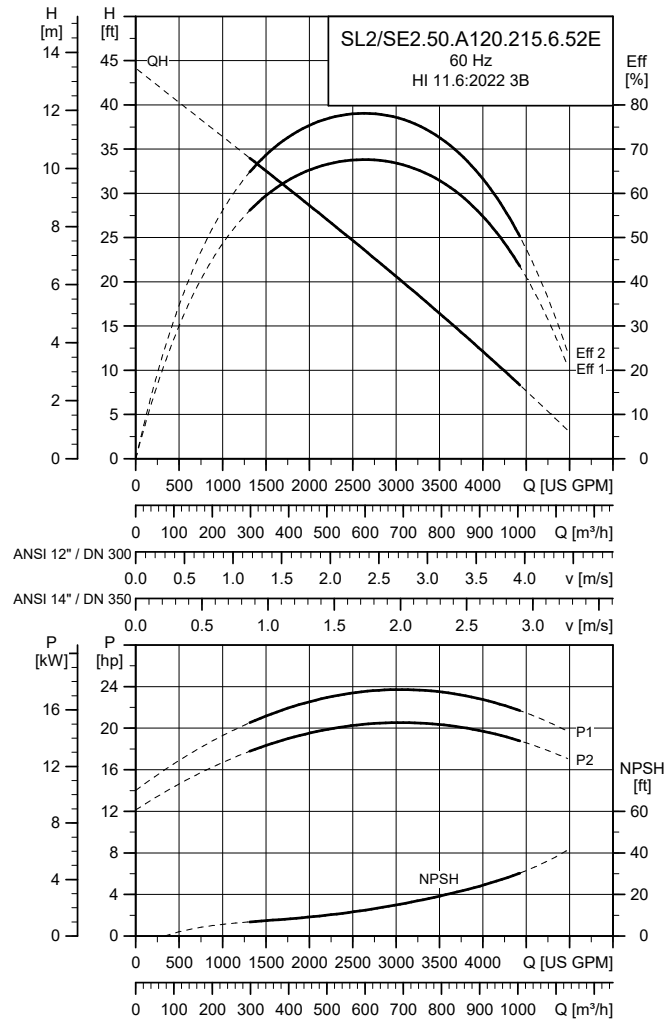

TM069941

Note: Performance grade 3B is the minimum standard to which any pump is tested before shipping from the factory. See, [Variants of customized pumps - Tests](#), for testing options. See, [How to read the performance curves](#).

Electrical data

Voltage variant	P1 [hp (kW)]	P2 [hp (kW)]	Number of poles	RPM	I _N [A]	I _{start} [A]	η _{motor} [%]			Cos φ			Moment of inertia [lbf ² (kgm ²)]	Breakdown torque M _{max} [lbf·ft (Nm)]
							1/2	3/4	1/1	1/2	3/4	1/1		
60S ²⁶⁾	25.2 (18.8)	21.5 (16)	6	1178	68	*	84	85	85	0.6	0.7	0.8	2.23 (0.094)	335 (454)
61R ²⁷⁾	25.2 (18.8)	21.5 (16)	6	1178	59/35	340/228	84/82	85/85	86/86	0.6/0.5	0.7/0.6	0.8/0.7	2.23 (0.094)	335 (454)
61M ²⁸⁾	24.8 (18.5)	21.5 (16)	6	1178	24-23	*	84	86	87	0.6	0.7	0.8	2.23 (0.094)	335 (454)

²⁶⁾ 3 x 208D

²⁷⁾ 3 x 230D/460Y

²⁸⁾ 3 x 575-600D

Pump data

Impeller diameter	Max. solids size	Outlet flange pressure (according to ASME B 16.5)	Max. installation depth
[in. (mm)]	[in. (mm)]	[PSI (PN)]	[ft (m)]
11.4 (289)	5.0 (125)	145 (10)	66 (20)

Note: Pumps with stainless steel closed S-tube® impellers have the same performance curves as the corresponding cast iron versions.

SL2/SE2.50.A120.255.6.52E

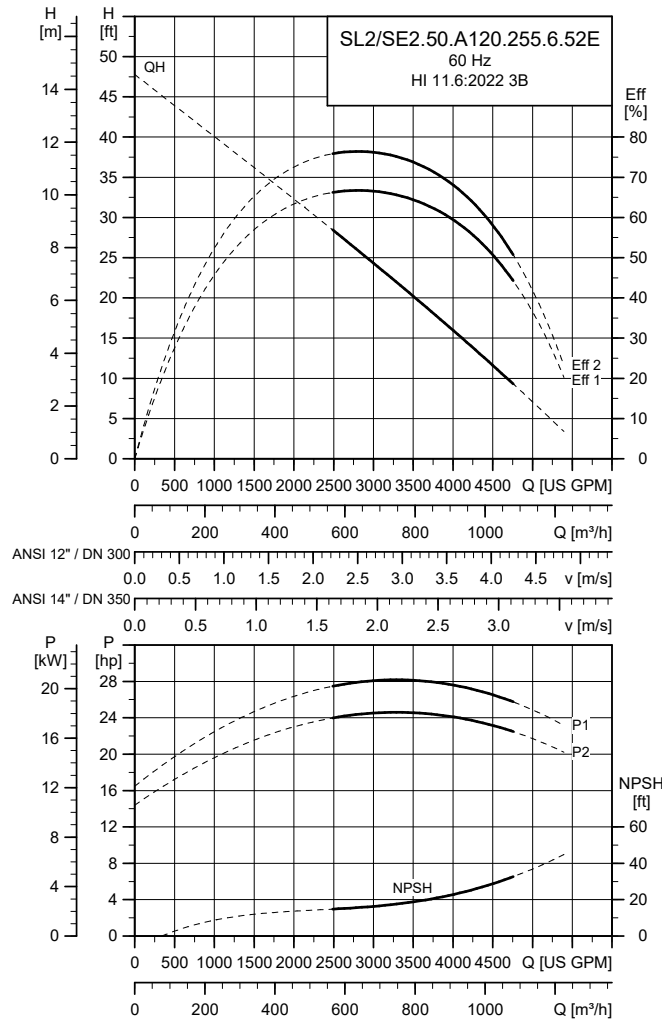

TM069942

Note: Performance grade 3B is the minimum standard to which any pump is tested before shipping from the factory. See, [Variants of customized pumps - Tests](#), for testing options. See, [How to read the performance curves](#).

Electrical data

Voltage variant	P1 [hp (kW)]	P2 [hp (kW)]	Number of poles	In [A]	Istart [A]	ηmotor [%]			Cos φ			Moment of inertia [lbf ² (kgm ²)]	Breakdown torque M _{max} [lbf·ft (Nm)]	
						1/2	3/4	1/1	1/2	3/4	1/1			
60S ²⁹⁾	30.3 (22.6)	25.5 (19)	6	1171	78	*	84	85	84	0.6	0.8	0.8	2.23 (0.094)	335 (454)
61R ³⁰⁾	30.6 (22.8)	25.5 (19)	6	1165	69/35	340/228	84/83	86/86	84/86	0.5/0.7	0.8/0.6	0.8/0.7	2.23 (0.094)	335 (454)
61M ³¹⁾	29.5 (22)	25.5 (19)	6	1171	28-27	*	85	86	86	0.6	0.8	0.8	2.23 (0.094)	335 (454)

29) 3 x 208D

30) 3 x 230D/460Y

31) 3 x 575-600D

Pump data

Impeller diameter	Max. solids size	Outlet flange pressure (according to ASME B 16.5)	Max. installation depth
[in. (mm)]	[in. (mm)]	[PSI (PN)]	[ft (m)]
11.8 (299)	5.0 (125)	145 (10)	66 (20)

Note: Pumps with stainless steel closed S-tube® impellers have the same performance curves as the corresponding cast iron versions.

Open S-tube® impeller

SL/SE.A40.175.2.52S

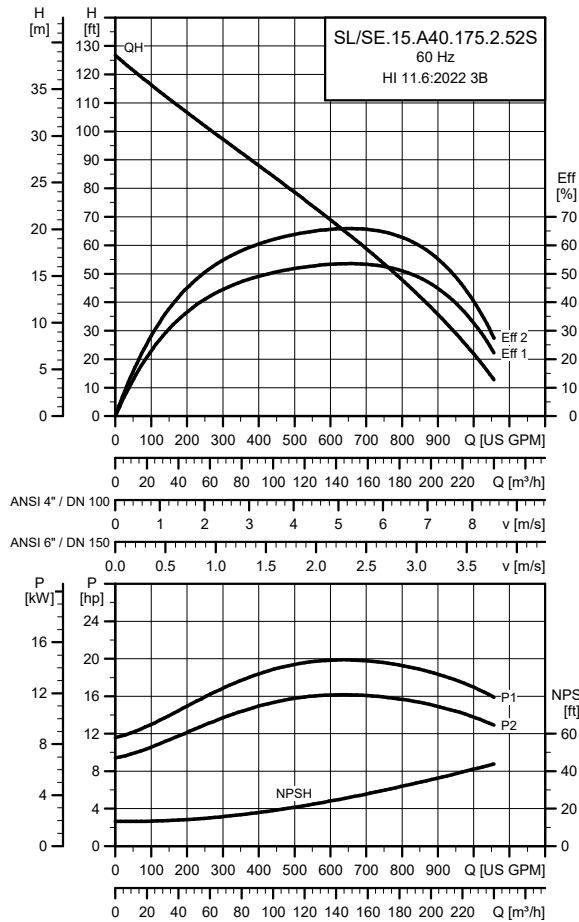

TM078492

Electrical data

Voltage variant	P1	P2	Number of poles	RPM	Starting method	I _N	I _{start}	η _{motor} [%]			Cos φ			Moment of inertia [lbf ² (kgm ²)]	Breakdown torque M _{max} [lbf·ft (Nm)]
								1/2	3/4	1/1	1/2	3/4	1/1		
60S 3 x 208 V	20.49 (15.3)	17.4 (13)	2	3569	D	51	270	78	0.82	0.85	0.73	0.8	0.85	1.16 (0.0490)	59 (80)
61R 3 x 230/460 V	20.49 (15.3)	17.4 (13)	2	3569	D	46/23	308/213	78	0.82	0.85	0.73	0.8	0.85	1.16 (0.0490)	74 (100)
61M 3 x 575-600 V	20.49 (15.3)	17.4 (13)	2	3569	D	19-18	155	78	0.82	0.85	0.73	0.8	0.85	1.16 (0.0490)	99 (134)

Pump data

Impeller diameter	Max. solids size	Outlet flange pressure (according to ASME B 16.5)	Max. installation depth
[in (mm)]	[in (mm)]	[PSI (PN)]	[ft (m)]
6.4 (162.00)	-	145 (10)	66 (20)

SL/SE.A40.200.2.52S

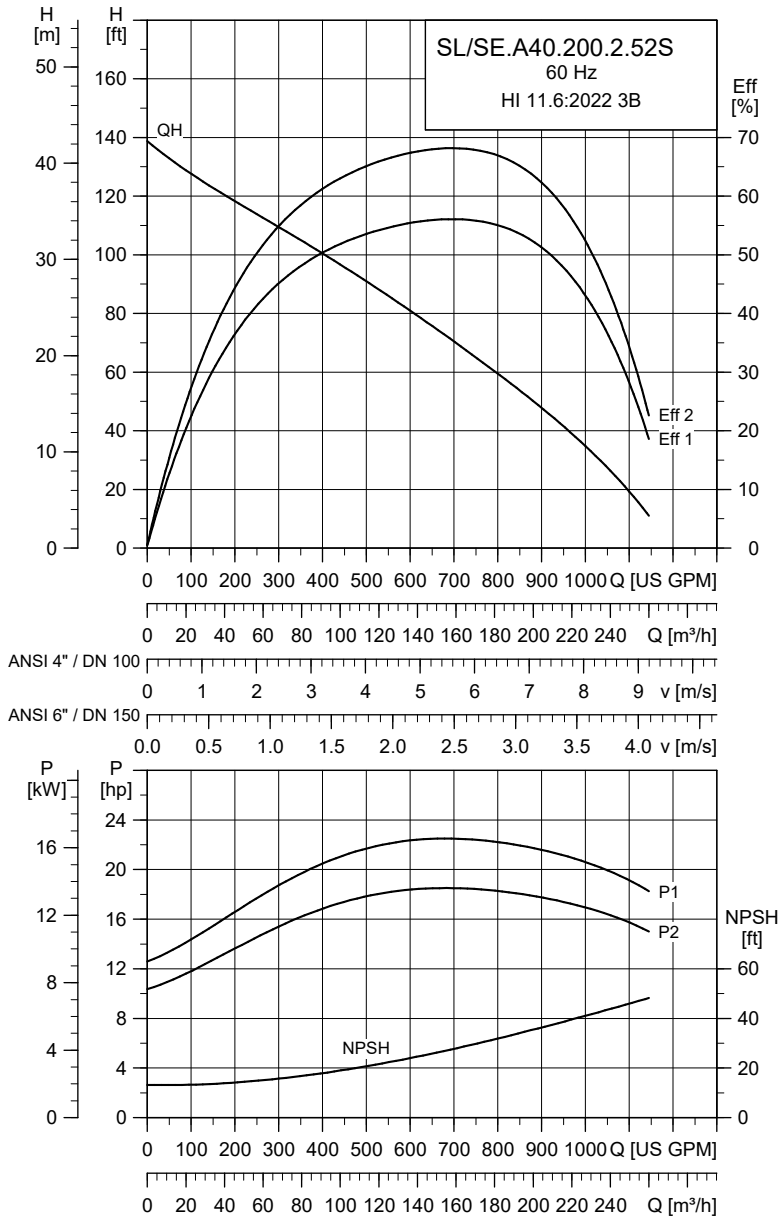

TM078493

Electrical data

Voltage variant	P1		P2		Number of poles	RPM	Starting method	I _N [A]	I _{start} [A]	η _{motor} [%]			Cos φ			Moment of inertia [lbf ² (kgm ²)]	Breakdown torque M _{max} [lbf ² (Nm)]
	[hp (kW)]	[hp (kW)]	1/2	3/4						1/1	1/2	3/4	1/1				
60S 3 x 208 V	23.47 (17.5)	20.1 (15)	2	3564	D	57	270	80	0.84	0.86	0.75	0.83	0.86	1.16 (0.0490)	59 (80)		
61R 3 x 230/460 V	23.47 (17.5)	20.1 (15)	2	3564	D	51/26	308/213	80	0.84	0.86	0.75	0.83	0.86	1.16 (0.0490)	74 (100)		
61M 3 x 575-600 V	23.47 (17.5)	20.1 (15)	2	3564	D	21-20	155	80	0.84	0.86	0.75	0.83	0.86	1.16 (0.0490)	99 (134)		

Pump data

Impeller diameter [in (mm)]	Max. solids size [in (mm)]	Outlet flange pressure (according to ASME B 16.5) [PSI (PN)]	Max. installation depth [ft (m)]
6.57 (167.00)	-	145 (10)	66 (20)

SL/SE.A40.230.2.52S

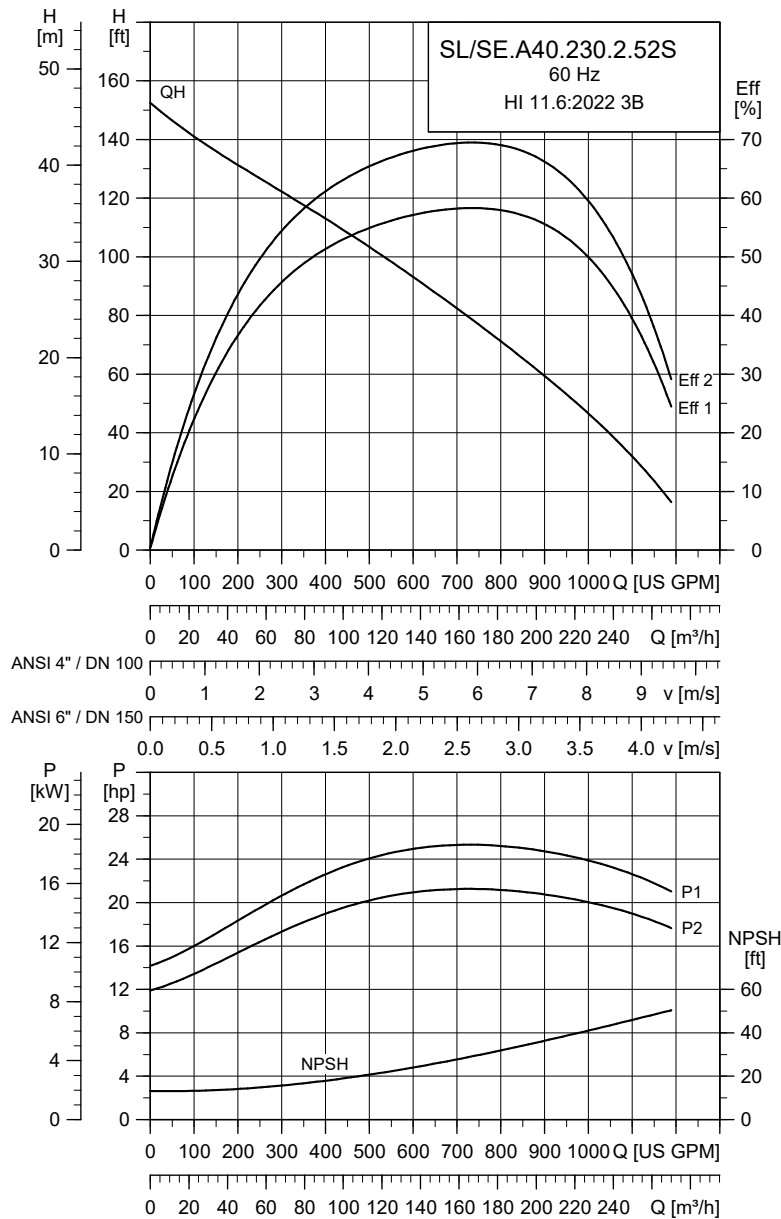

TM078494

Electrical data

Voltage variant	P1		P2		Number of poles	RPM	Starting method	I_N	I_{start}	η_{motor} [%]			$\cos \varphi$			Moment of inertia	Breakdown torque M_{max}
	[hp (kW)]	[hp (kW)]	1/2	3/4						1/1	1/2	3/4	1/1	[lbf ² (kgm ²)]	[lbf ² (Nm)]		
60S 3 x 208 V	26.18 (19.5)	22.8 (17)	2	3567	D	63	477	82	0.85	0.87	0.73	0.82	0.86	1.38 (0.0580)	137 (186)		
61R 3 x 230/460 V	26.18 (19.5)	22.8 (17)	2	3567	D	57/29	373/258	82	0.85	0.87	0.73	0.82	0.86	1.38 (0.0580)	104 (141)		
61M 3 x 575-600 V	26.18 (19.5)	22.8 (17)	2	3567	D	23-22	207	82	0.85	0.87	0.75	0.84	0.88	1.38 (0.0580)	130 (176)		

Pump data

Impeller diameter	Max. solids size	Outlet flange pressure (according to ASME B 16.5)		Max. installation depth
[in (mm)]	[in (mm)]	[PSI (PN)]		[ft (m)]
6.77 (172.00)	-	145 (10)		66 (20)

SL/SE.A40.250.2.52S

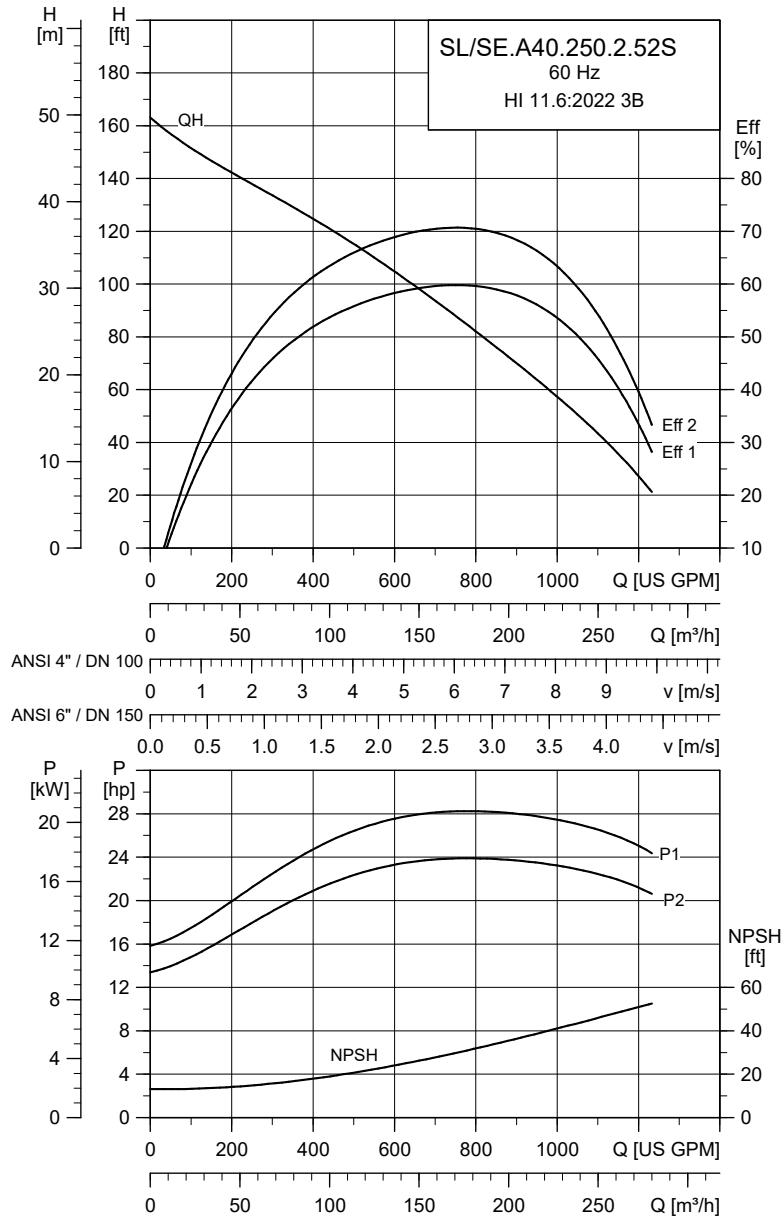

TM078495

Electrical data

Voltage variant	P1		P2		Number of poles	RPM	Starting method	I _N [A]	I _{start} [A]	η _{motor} [%]			Cos φ			Moment of inertia [lbf ² (kgm ²)]	Breakdown torque M _{max} [lbf*ft (Nm)]
	[hp (kW)]	[hp (kW)]	1/2	3/4						1/1	1/2	3/4	1/1				
60S 3 x 208 V	28.39 (21.2)	24.8 (18.5)	2	3565	D	69	477	83	0.86	0.87	0.75	0.84	0.86	1.38 (0.0580)	137 (186)		
61R 3 x 230/460 V	28.39 (21.2)	24.8 (18.5)	2	3565	D	62/31	373/258	83	0.86	0.87	0.75	0.84	0.86	1.38 (0.0580)	104 (141)		
61M 3 x 575-600 V	28.39 (21.2)	24.8 (18.5)	2	3565	D	25-24	207	83	0.86	0.87	0.77	0.86	0.88	1.38 (0.0580)	130 (176)		

Pump data

Impeller diameter [in (mm)]	Max. solids size [in (mm)]	Outlet flange pressure (according to ASME B 16.5) [PSI (PN)]	Max. installation depth [ft (m)]
6.93 (176.00)	-	145 (10)	66 (20)

SL/SE.A40.300.2.52S

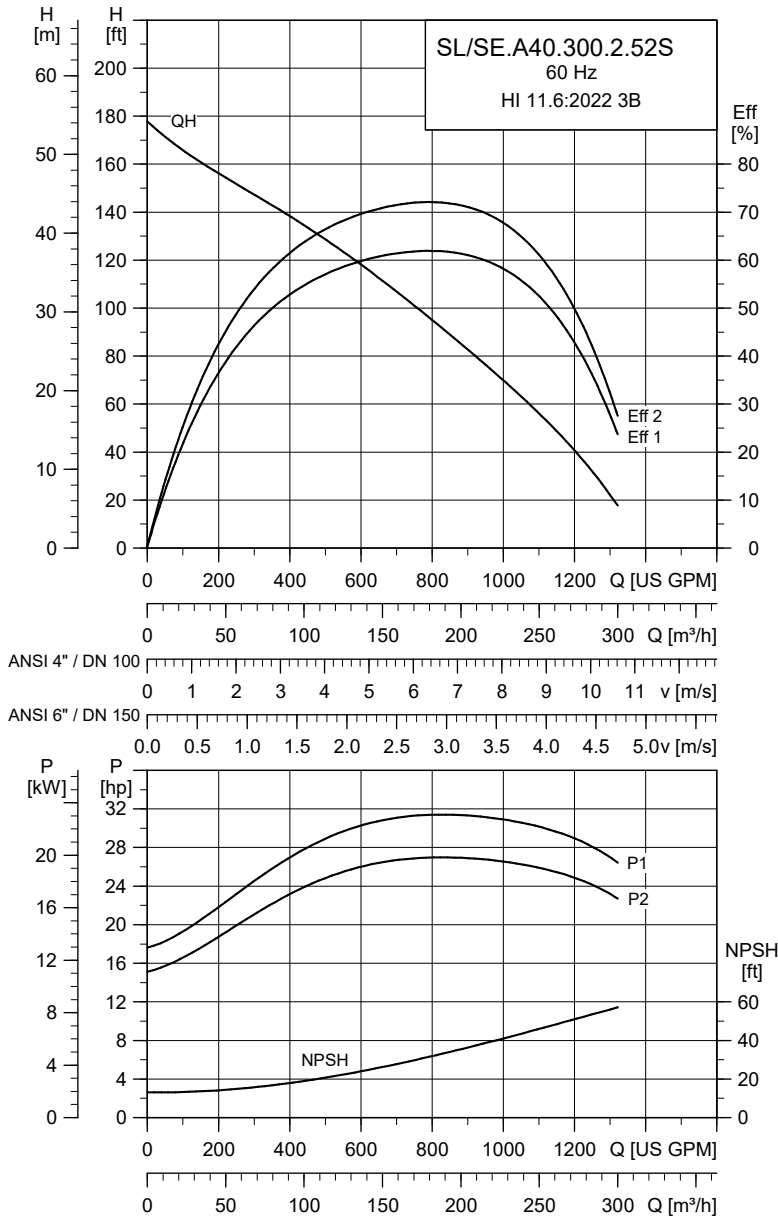

TM078496

Electrical data

Voltage variant	P1		P2		Number of poles	RPM	Starting method	I _N [A]	I _{start} [A]	η _{motor} [%]			Cos φ			Moment of inertia [lbf ² (kgm ²)]	Breakdown torque M _{max} [lbf ² (Nm)]
	[hp (kW)]	[hp (kW)]	1/2	3/4						1/1	1/2	3/4	1/1				
60S 3 x 208 V	33.22 (24.8)	29.5 (22)	2	3575	D	83	600	85	0.87	0.89	0.62	0.75	0.84	1.54 (0.0650)	150 (204)		
61R 3 x 230/460 V	33.22 (24.8)	29.5 (22)	2	3575	D	75/38	723/499	85	0.87	0.89	0.62	0.75	0.84	1.54 (0.0650)	181 (245)		
61M 3 x 575-600 V	33.22 (24.8)	29.5 (22)	2	3575	D	31-30	405	85	0.87	0.89	0.59	0.72	0.81	1.54 (0.0650)	239 (324)		

Pump data

Impeller diameter	Max. solids size	Outlet flange pressure (according to ASME B 16.5)	Max. installation depth
[in (mm)]	[in (mm)]	[PSI (PN)]	[ft (m)]
7.12 (180.80)	-	145 (10)	66 (20)

SL/SE.A40.335.2.52S

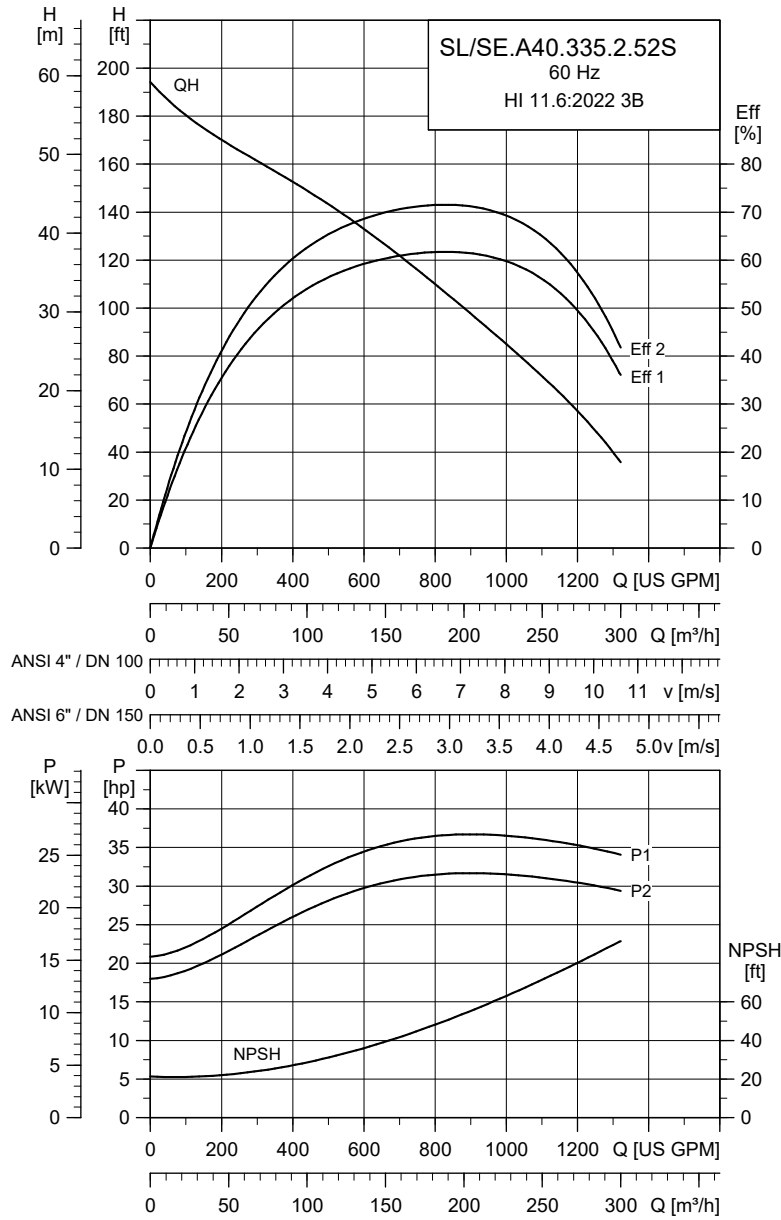

TM078497

Electrical data

Voltage variant	P1	P2	Number of poles	RPM	Starting method	I _N [A]	I _{start} [A]	η _{motor} [%]			Cos φ			Moment of inertia [lbf ² (kgm ²)]	Breakdown torque M _{max} [lbf·ft (Nm)]
	[hp (kW)]	[hp (kW)]						1/2	3/4	1/1	1/2	3/4	1/1		
60S 3 x 208 V	37.6 (28)	33.5 (25)	2	3572	D	91	600	86	0.88	0.89	0.66	0.79	0.86	1.54 (0.0650)	150 (204)
61R 3 x 230/460 V	37.6 (28)	33.5 (25)	2	3572	D	82/41	723/499	86	0.88	0.89	0.66	0.79	0.86	1.54 (0.0650)	181 (245)
61M 3 x 575-600 V	37.6 (28)	33.5 (25)	2	3572	D	34-33	405	86	0.88	0.89	0.63	0.76	0.83	1.54 (0.0650)	239 (324)

Pump data

Impeller diameter	Max. solids size	Outlet flange pressure (according to ASME B 16.5)	Max. installation depth
[in (mm)]	[in (mm)]	[PSI (PN)]	[ft (m)]
7.39 (187.60)	-	145 (10)	66 (20)

SL/SE.A40.390.2.52S

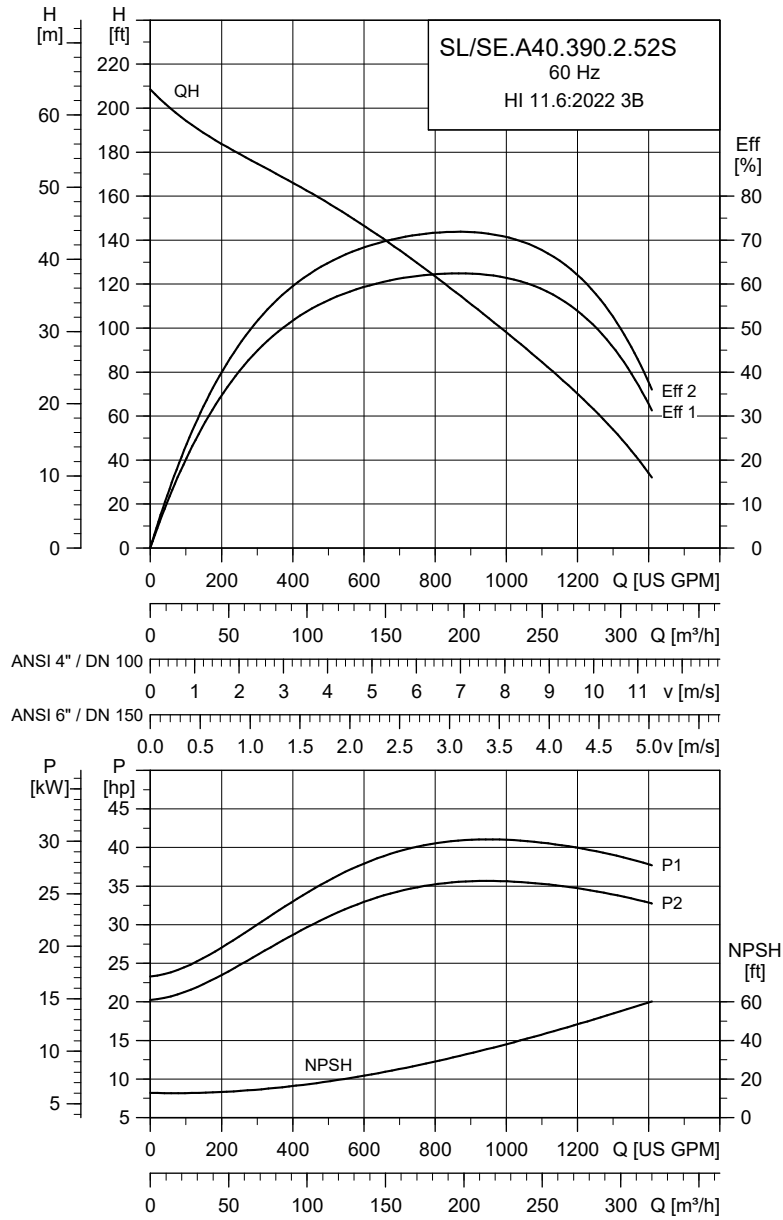

TM078498

Electrical data

Voltage variant	P1		P2		Number of poles	RPM	Starting method	I _N [A]	I _{start} [A]	η _{motor} [%]			Cos φ			Moment of inertia [lbf ² (kgm ²)]	Breakdown torque M _{max} [lbf ² (Nm)]
	[hp (kW)]	[hp (kW)]	1/2	3/4						1/1	1/2	3/4	1/1				
60S 3 x 208 V	43.6 (32.5)	38.9 (29)	2	3568	D	103	600	87	0.89	0.89	0.71	0.83	0.88	1.54 (0.0650)	150 (204)		
61R 3 x 230/460 V	43.6 (32.5)	38.9 (29)	2	3568	D	93/47	723/499	87	0.89	0.89	0.71	0.83	0.88	1.54 (0.0650)	181 (245)		
61M 3 x 575-600 V	43.6 (32.5)	38.9 (29)	2	3568	D	39-37	405	87	0.89	0.89	0.68	0.8	0.85	1.54 (0.0650)	239 (324)		

Pump data

Impeller diameter	Max. solids size	Outlet flange pressure (according to ASME B 16.5)	Max. installation depth
[in (mm)]	[in (mm)]	[PSI (PN)]	[ft (m)]
7.57 (192.40)	-	145 (10)	66 (20)

SL/SE.A40.420.2.52S

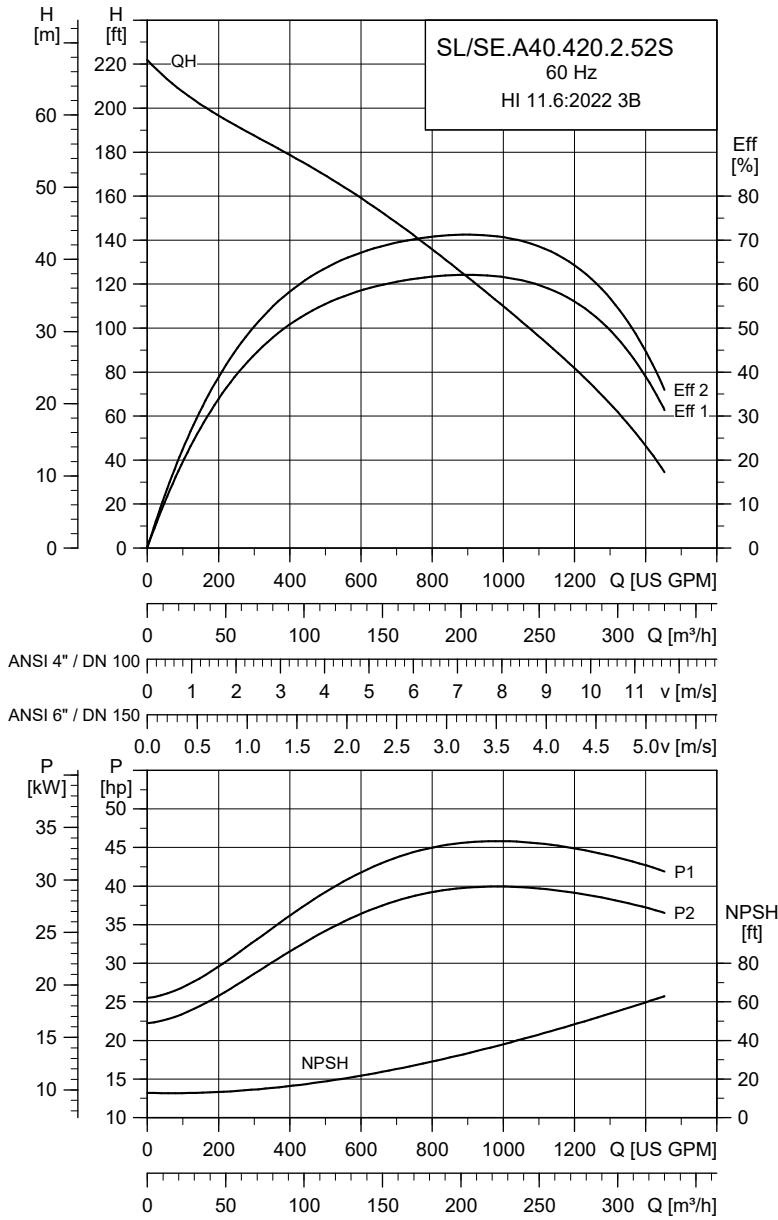

TM078499

Electrical data

Voltage variant	P1	P2	Number of poles	RPM	Starting method	I _N	I _{start}	η _{motor} [%]			Cos φ			Moment of inertia	Breakdown torque M _{max}
								1/2	3/4	1/1	1/2	3/4	1/1		
60S 3 x 208 V	46.71 (34.8)	41.6 (31)	2	3566	D	110	600	87	0.89	0.89	0.73	0.85	0.88	1.54 (0.0650)	150 (204)
61R 3 x 230/460 V	46.71 (34.8)	41.6 (31)	2	3566	D	100/50	723/499	87	0.89	0.89	0.73	0.85	0.88	1.54 (0.0650)	181 (245)
61M 3 x 575-600 V	46.71 (34.8)	41.6 (31)	2	3566	D	42-40	405	87	0.89	0.89	0.7	0.82	0.85	1.54 (0.0650)	239 (324)

Pump data

Impeller diameter	Max. solids size	Outlet flange pressure (according to ASME B 16.5)	Max. installation depth
[in (mm)]	[in (mm)]	[PSI (PN)]	[ft (m)]
7.71 (196.00)	-	145 (10)	66 (20)

SL/SE.A40.120.4.52H

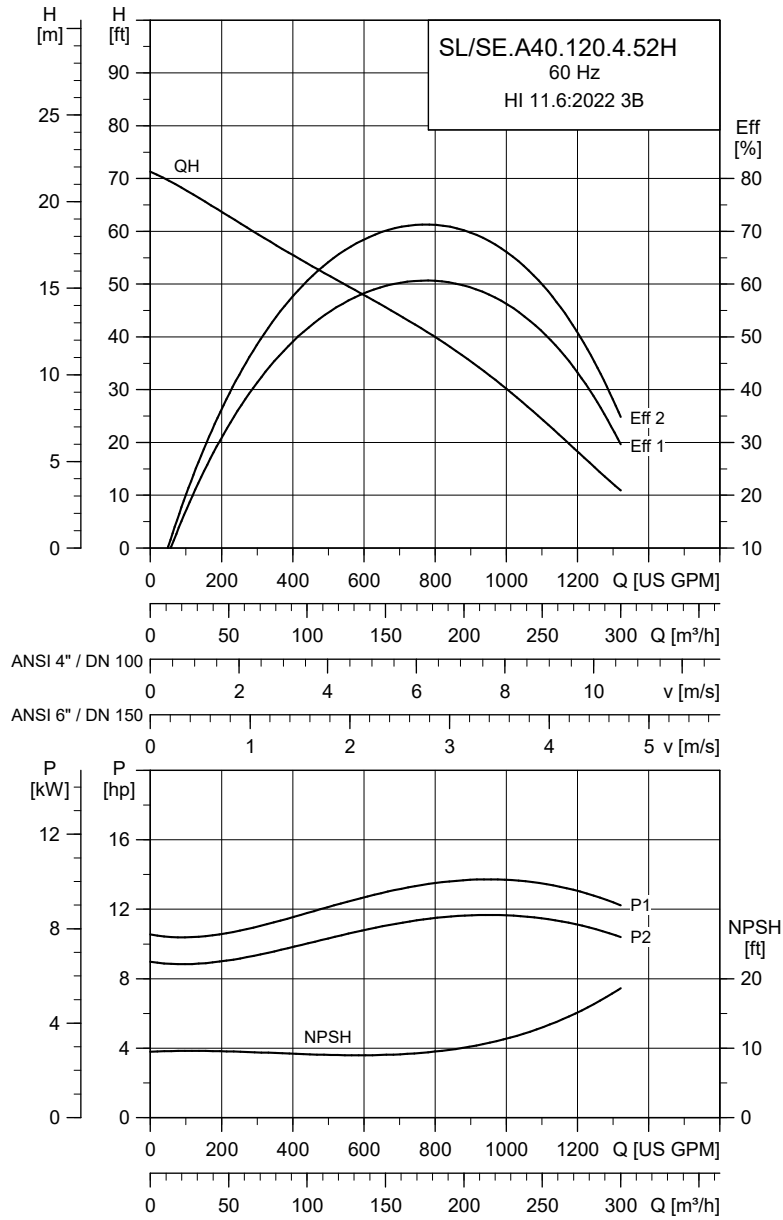

TM078500

Electrical data

Voltage variant	P1		P2		Number of poles	RPM	Starting method	I _N [A]	I _{start} [A]	η _{motor} [%]			Cos φ			Moment of inertia [lbf ² (kgm ²)]	Breakdown torque M _{max} [lbf ² (Nm)]
	[hp (kW)]	[hp (kW)]	1/2	3/4						1/1	1/2	3/4	1/1				
60S 3 x 208 V	13.78 (10.3)	12.1 (9)	4	1785	D	37	332	82	0.85	0.88	0.68	0.73	0.78	1.38 (0.0580)	166 (225)		
61R 3 x 230/460 V	13.78 (10.3)	12.1 (9)	4	1785	D	32/16	279/192	82	0.85	0.88	0.72	0.77	0.82	1.38 (0.0580)	121 (164)		
61M 3 x 575-600 V	13.78 (10.3)	12.1 (9)	4	1785	D	14-13	155	82	0.85	0.88	0.69	0.74	0.79	1.38 (0.0580)	179 (243)		

Pump data

Impeller diameter	Max. solids size	Outlet flange pressure (according to ASME B 16.5)	Max. installation depth
[in (mm)]	[in (mm)]	[PSI (PN)]	[ft (m)]
9.1 (230.80)	-	145 (10)	66 (20)

SL/SE.A40.150.4.52H

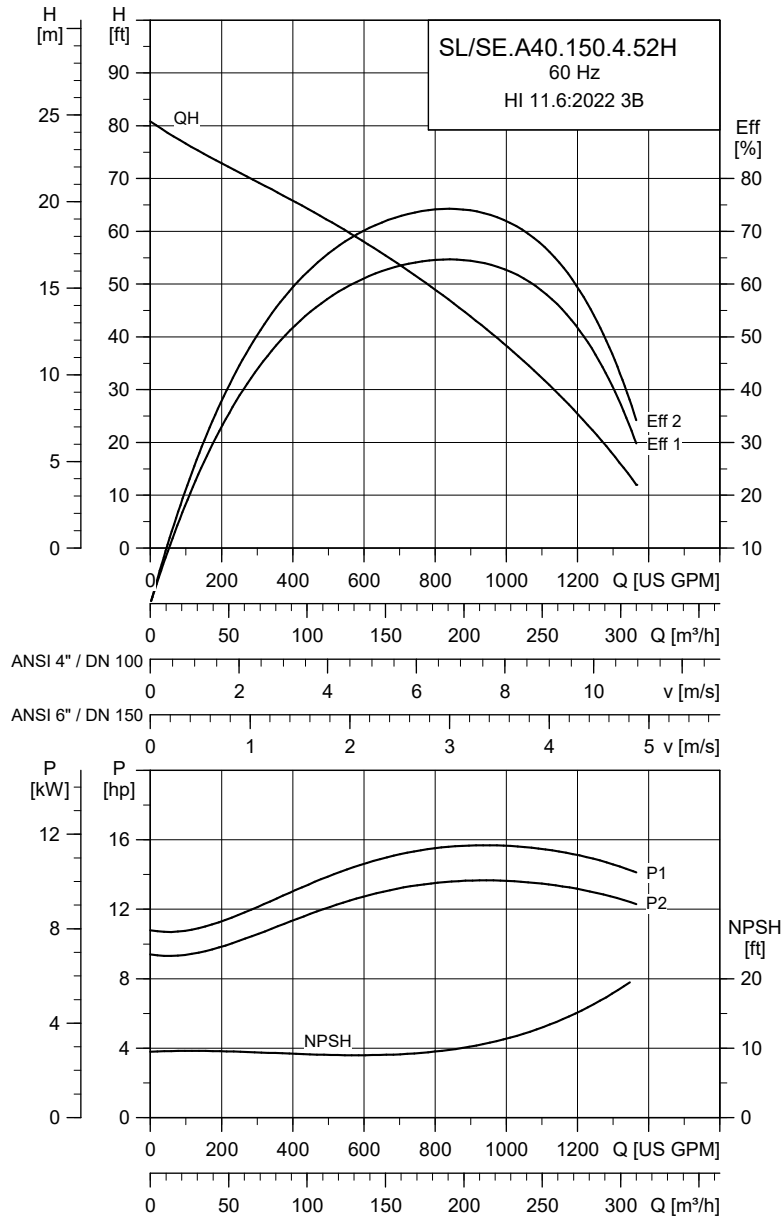

TM078501

Electrical data

Voltage variant	P1		P2		Number of poles	RPM	Starting method	I _N [A]	I _{start} [A]	η _{motor} [%]			Cos φ			Moment of inertia [lbf ² (kgm ²)]	Breakdown torque M _{max} [lbf ² (Nm)]
	[hp (kW)]	[hp (kW)]	1/2	3/4						1/1	1/2	3/4	1/1				
60S 3 x 208 V	16.65 (12.4)	14.8 (11)	4	1782	D	43	332	84	0.87	0.89	0.7	0.76	0.82	1.38 (0.0580)	166 (225)		
61R 3 x 230/460 V	16.65 (12.4)	14.8 (11)	4	1782	D	37/19	279/192	84	0.87	0.89	0.74	0.8	0.86	1.38 (0.0580)	121 (164)		
61M 3 x 575-600 V	16.65 (12.4)	14.8 (11)	4	1782	D	16-15	155	84	0.87	0.89	0.71	0.77	0.83	1.38 (0.0580)	179 (243)		

Pump data

Impeller diameter [in (mm)]	Max. solids size [in (mm)]	Outlet flange pressure (according to ASME B 16.5) [PSI (PN)]	Max. installation depth [ft (m)]
9.4 (239.00)	-	145 (10)	66 (20)

SL/SE.A40.175.4.52H

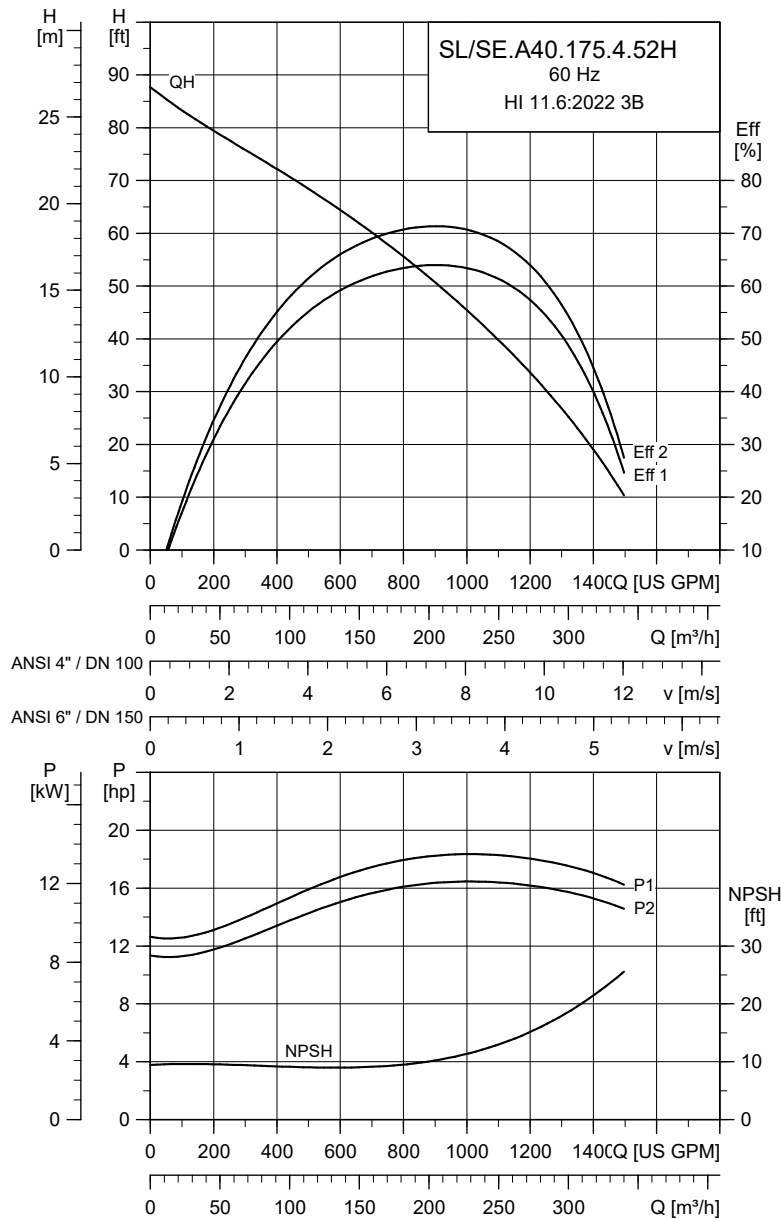

TM078502

Electrical data

Voltage variant	P1		P2		Number of poles	RPM	Starting method	I_N	I_{start}	η_{motor} [%]			$\cos \varphi$			Moment of inertia [lbf ² (kgm ²)]	Breakdown torque M_{max} [lbf ² (Nm)]
	[hp (kW)]	[hp (kW)]	[A]	[A]						1/2	3/4	1/1	1/2	3/4	1/1		
60S 3 x 208 V	19.32 (14.4)	17.4 (13)	4	1785	D	50	420	86	0.89	0.9	0.64	0.75	0.81	1.78 (0.0750)	260 (353)		
61R 3 x 230/460 V	19.32 (14.4)	17.4 (13)	4	1785	D	44/22	420/290	86	0.89	0.9	0.66	0.77	0.83	1.78 (0.0750)	184 (249)		
61M 3 x 575-600 V	19.32 (14.4)	17.4 (13)	4	1785	D	18-17	207	86	0.89	0.9	0.66	0.77	0.83	1.78 (0.0750)	144 (195)		

Pump data

Impeller diameter	Max. solids size	Outlet flange pressure (according to ASME B 16.5)	Max. installation depth
[in (mm)]	[in (mm)]	[PSI (PN)]	[ft (m)]
9.78 (248.50)	-	145 (10)	66 (20)

SL/SE.A40.200.4.52H

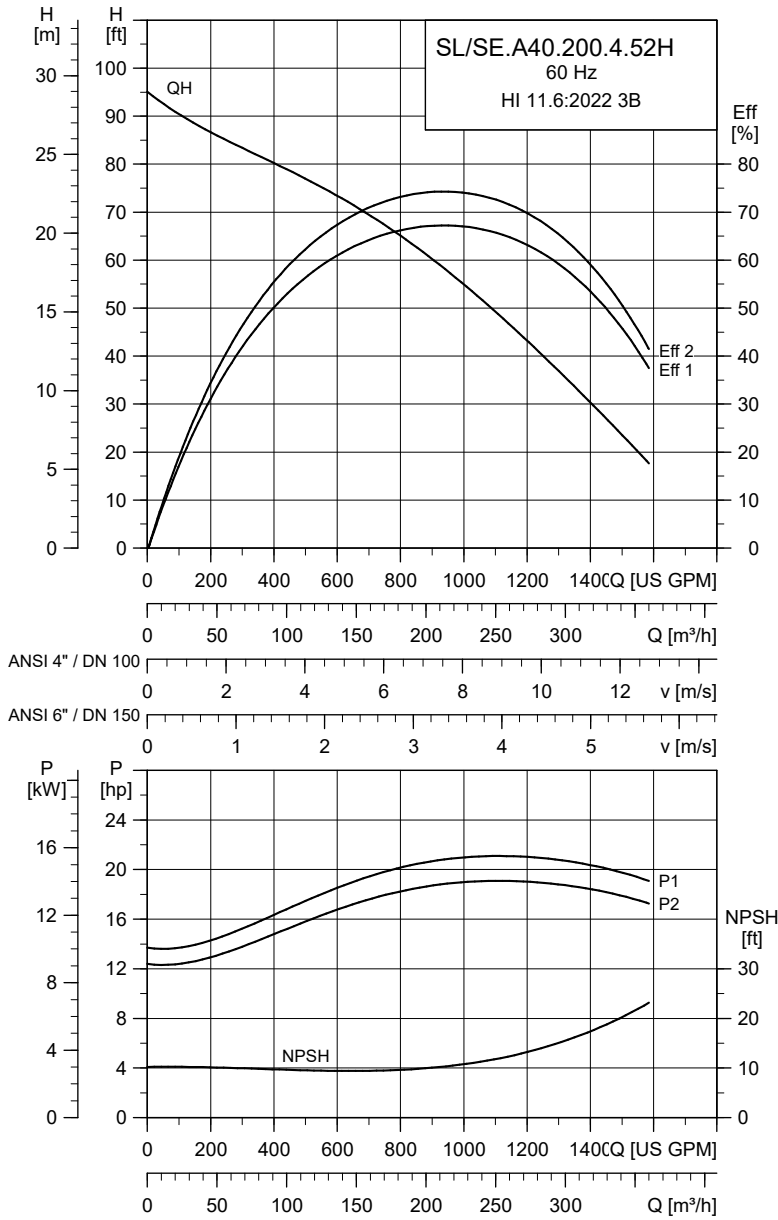

TM078503

Electrical data

Voltage variant	P1 [hp (kW)]	P2 [hp (kW)]	Number of poles	RPM	Starting method	$\eta_{\text{motor}} [\%]$						Moment of inertia		Breakdown torque M_{max} [lbf*ft (Nm)]	
						I_N [A]	I_{start} [A]	1/2	3/4	1/1	1/2	3/4	1/1		[lbf ² (kgm ²)]
60S 3 x 208 V	22.25 (16.6)	20.1 (15)	4	1783	D	57	420	87	0.9	0.9	0.68	0.78	0.82	1.78 (0.0750)	260 (353)
61R 3 x 230/460 V	22.25 (16.6)	20.1 (15)	4	1783	D	50/25	420/290	87	0.9	0.9	0.7	0.8	0.84	1.78 (0.0750)	184 (249)
61M 3 x 575-600 V	22.25 (16.6)	20.1 (15)	4	1783	D	20-20	207	87	0.9	0.9	0.7	0.8	0.84	1.78 (0.0750)	144 (195)

Pump data

Impeller diameter [in (mm)]	Max. solids size [in (mm)]	Outlet flange pressure (according to ASME B 16.5) [PSI (PN)]	Max. installation depth [ft (m)]
10.06 (255.50)	-	145 (10)	66 (20)

SL/SE.A40.245.4.52H

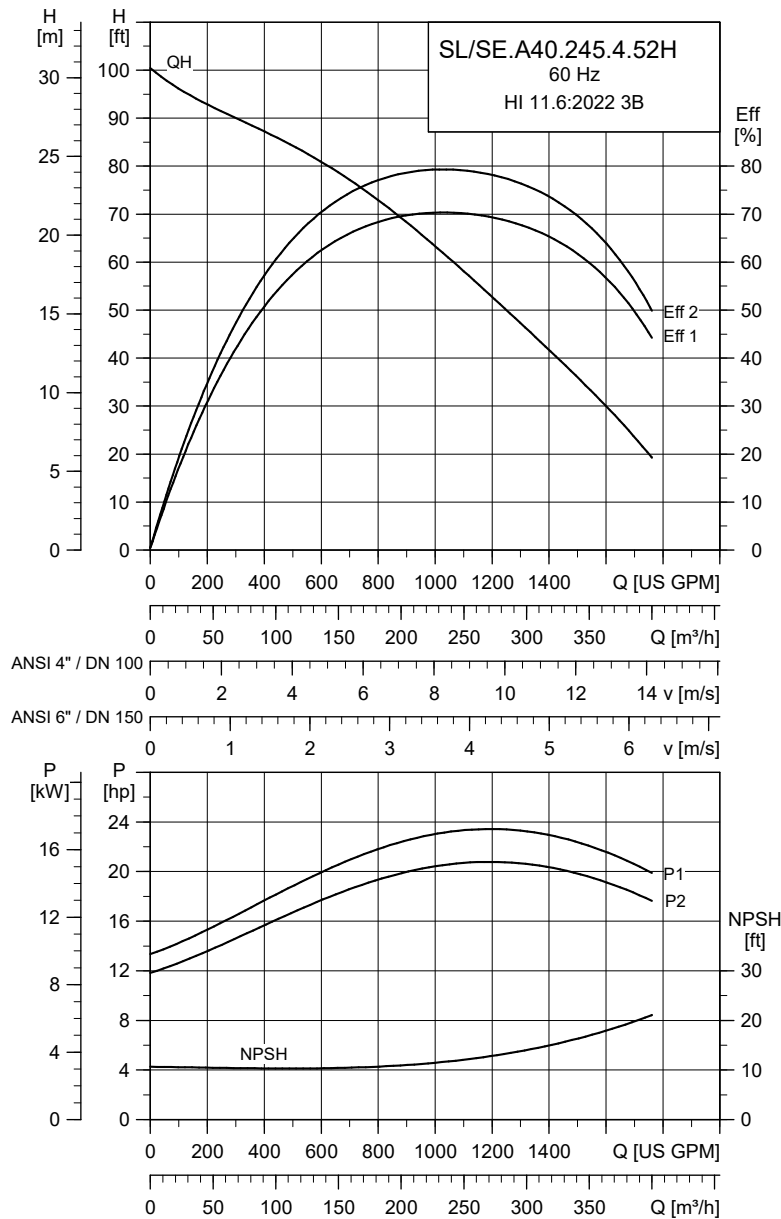

TM078504

Electrical data

Voltage variant	P1		P2		Number of poles	RPM	Starting method	I_N	I_{start}	η_{motor} [%]			$\cos \varphi$			Moment of inertia	Breakdown torque M_{max}
	[hp (kW)]	[hp (kW)]	1/2	3/4						1/1	1/2	3/4	1/1	[lbf ² (kgm ²)]	[lbf ² (Nm)]		
60S 3 x 208 V	27.14 (20.2)	24.1 (18)	4	1783	D	70	830	87	0.88	0.89	0.66	0.74	0.81	1.78 (0.0750)	371 (503)		
61R 3 x 230/460 V	27.14 (20.2)	24.1 (18)	4	1783	D	64/32	534/363	87	0.88	0.89	0.66	0.74	0.81	1.78 (0.0750)	260 (353)		
61M 3 x 575-600 V	27.14 (20.2)	24.1 (18)	4	1783	D	26-25	292	87	0.88	0.89	0.64	0.72	0.79	1.78 (0.0750)	320 (434)		

Pump data

Impeller diameter	Max. solids size	Outlet flange pressure (according to ASME B 16.5)		Max. installation depth
[in (mm)]	[in (mm)]	[PSI (PN)]		[ft (m)]
10.24 (260.00)	-	145 (10)		66 (20)

SL/SE.A40.270.4.52H

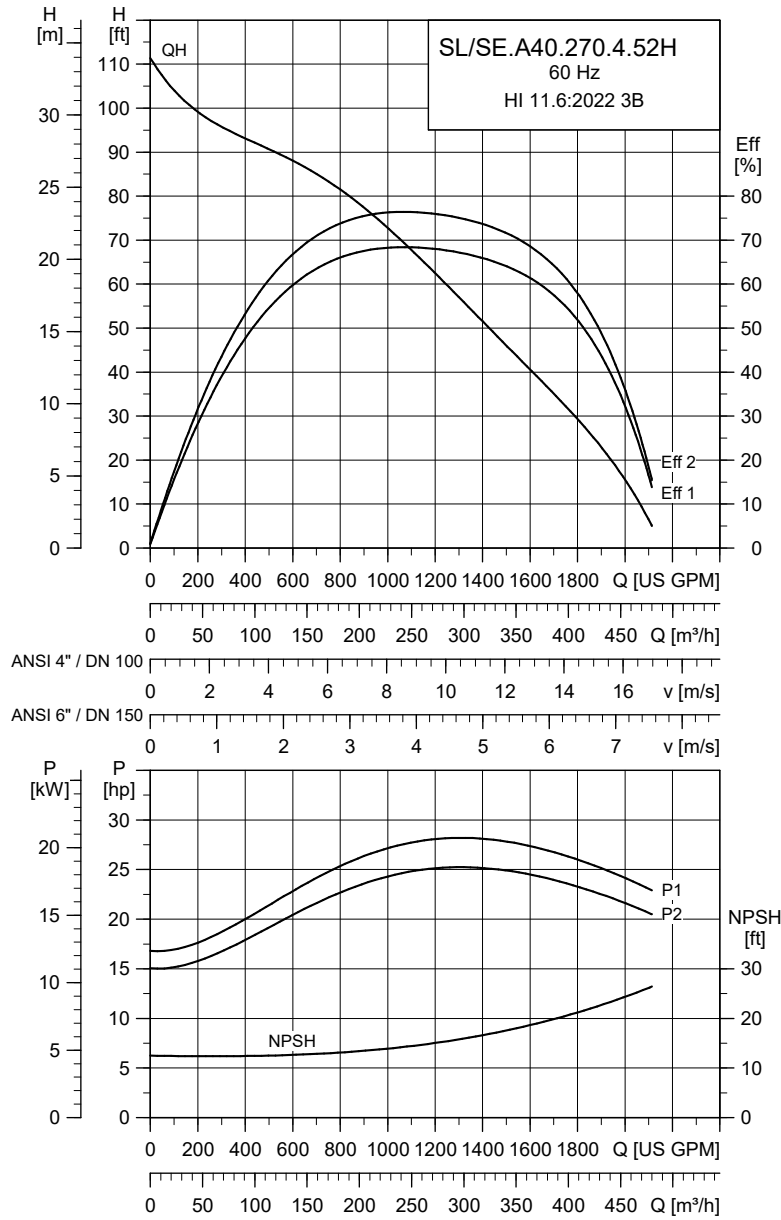

TM078505

Electrical data

Voltage variant	P1		P2		Number of poles	RPM	Starting method	I _N [A]	I _{start} [A]	η _{motor} [%]			Cos φ			Moment of inertia [lbf ² (kgm ²)]	Breakdown torque M _{max} [lbf ² (Nm)]
	[hp (kW)]	[hp (kW)]	1/2	3/4						1/1	1/2	3/4	1/1				
60S 3 x 208 V	30.05 (22.4)	26.8 (20)	4	1782	D	76	830	88	0.88	0.89	0.68	0.77	0.83	1.78 (0.0750)	371 (503)		
61R 3 x 230/460 V	30.05 (22.4)	26.8 (20)	4	1782	D	68/34	534/363	88	0.88	0.89	0.68	0.77	0.83	1.78 (0.0750)	260 (353)		
61M 3 x 575-600 V	30.05 (22.4)	26.8 (20)	4	1782	D	28-27	292	88	0.88	0.89	0.66	0.75	0.81	1.78 (0.0750)	320 (434)		

Pump data

Impeller diameter [in (mm)]	Max. solids size [in (mm)]	Outlet flange pressure (according to ASME B 16.5) [PSI (PN)]	Max. installation depth [ft (m)]
10.9 (276.80)	-	145 (10)	66 (20)

SL/SE.A40.300.4.52H

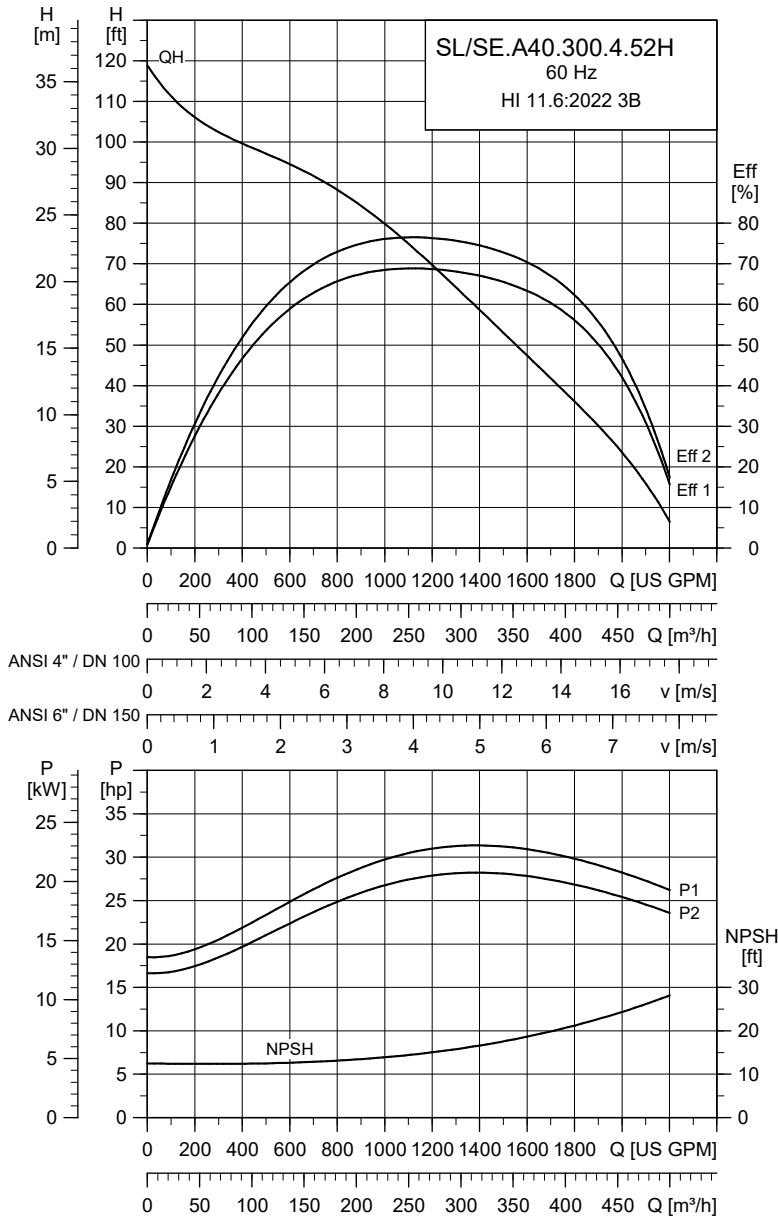

TM078506

Electrical data

Voltage variant	P1		P2		Number of poles	RPM	Starting method	I _N [A]	I _{start} [A]	η _{motor} [%]			Cos φ			Moment of inertia [lbf ² (kgm ²)]	Breakdown torque M _{max} [lbf ² (Nm)]
	[hp (kW)]	[hp (kW)]	1/2	3/4						1/1	1/2	3/4	1/1				
60S 3 x 208 V	32.93 (24.6)	29.5 (22)	4	1779	D	81	830	88	0.89	0.9	0.7	0.79	0.84	1.78 (0.0750)	371 (503)		
61R 3 x 230/460 V	32.93 (24.6)	29.5 (22)	4	1779	D	73/37	534/363	88	0.89	0.9	0.7	0.79	0.84	1.78 (0.0750)	260 (353)		
61M 3 x 575-600 V	32.93 (24.6)	29.5 (22)	4	1779	D	30-29	292	88	0.89	0.9	0.68	0.77	0.82	1.78 (0.0750)	320 (434)		

Pump data

Impeller diameter	Max. solids size	Outlet flange pressure (according to ASME B 16.5)	Max. installation depth
[in (mm)]	[in (mm)]	[PSI (PN)]	[ft (m)]
11.18 (284.00)	-	145 (10)	66 (20)

SL/SE.A40.330.4.52H

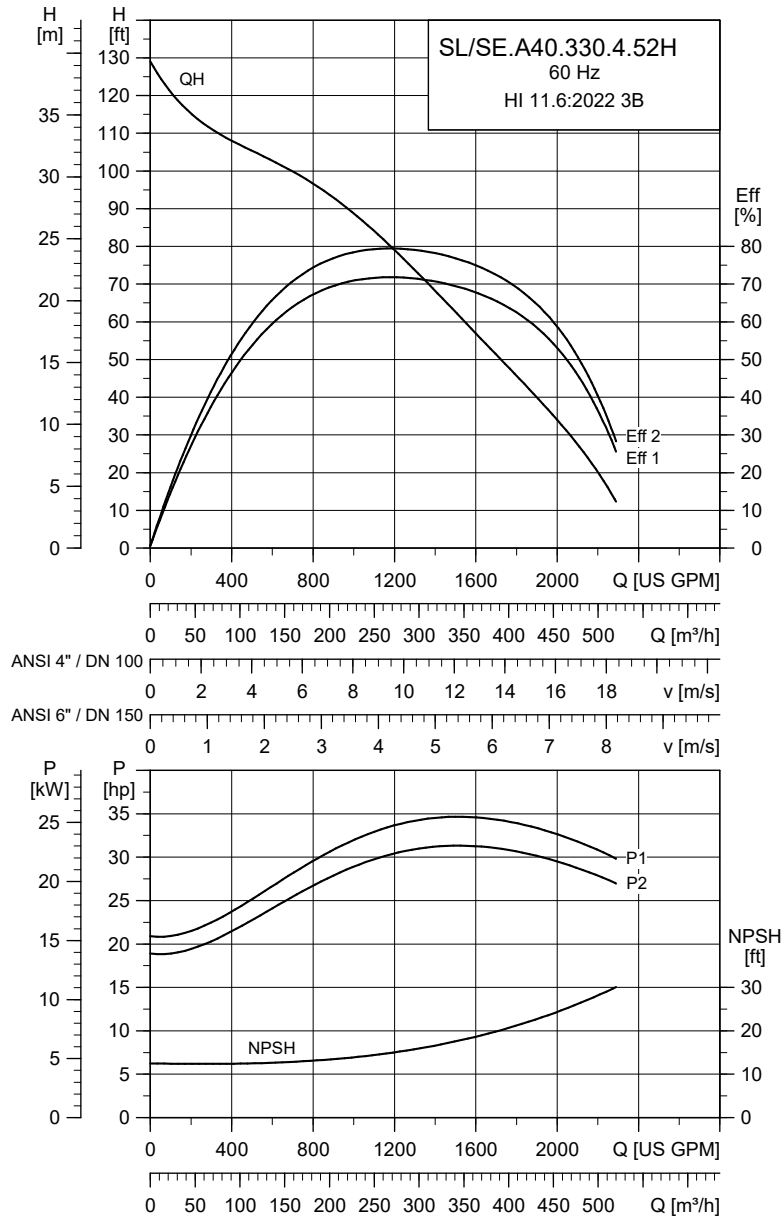

TM078507

Electrical data

Voltage variant	P1		P2		Number of poles	RPM	Starting method	I _N	I _{start}	η _{motor} [%]			Cos φ			Moment of inertia	Breakdown torque M _{max}
	[hp (kW)]	[hp (kW)]	1/2	3/4						1/1	1/2	3/4	1/1	[lbf ² (kgm ²)]	[lbf ² (Nm)]		
60S 3 x 208 V	36.51 (27.2)	32.9 (24.5)	4	1776	D	88	830	88	0.89	0.9	0.72	0.81	0.86	1.78 (0.0750)	371 (503)		
61R 3 x 230/460 V	36.51 (27.2)	32.9 (24.5)	4	1776	D	80/40	534/363	88	0.89	0.9	0.72	0.81	0.86	1.78 (0.0750)	260 (353)		
61M 3 x 575-600 V	36.51 (27.2)	32.9 (24.5)	4	1776	D	33-32	292	88	0.89	0.9	0.7	0.79	0.84	1.78 (0.0750)	320 (434)		

Pump data

Impeller diameter	Max. solids size	Outlet flange pressure (according to ASME B 16.5)	Max. installation depth
[in (mm)]	[in (mm)]	[PSI (PN)]	[ft (m)]
11.46 (291.00)	-	145 (10)	66 (20)

SL/SE.A60.120.4.52H

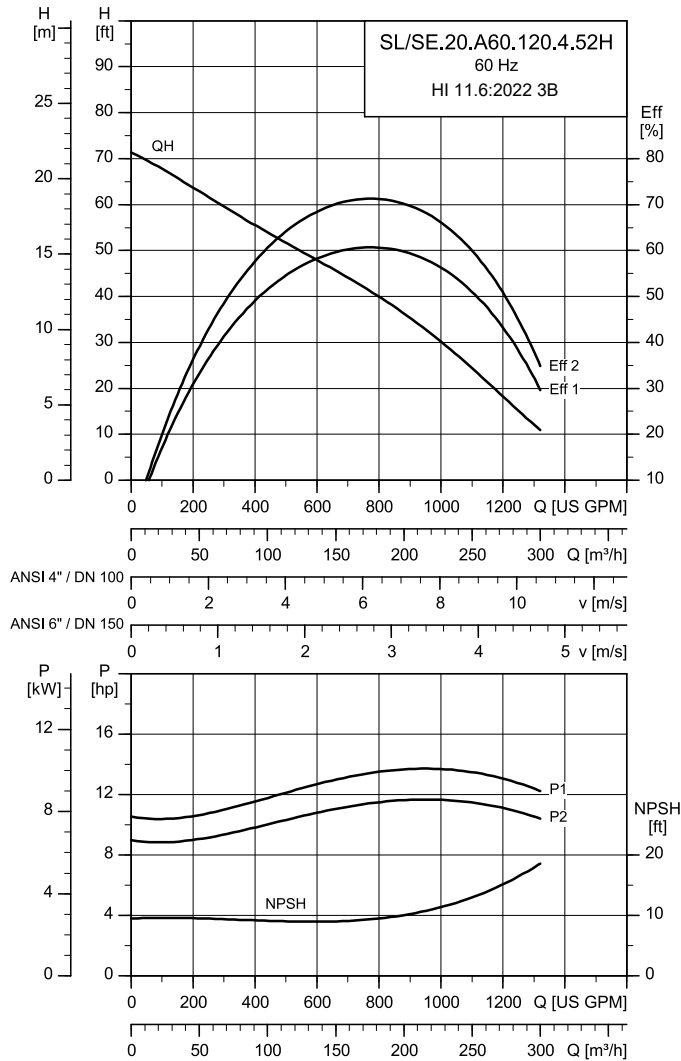

TM082751

Electrical data

Voltage variant	P1	P2	Number of poles	RPM	Starting method	I _N	I _{start}	η _{motor} [%]			Cos φ		Moment of inertia [lbft ² (kgm ²)]	Breakdown torque M _{max} [lb*ft (Nm)]	
	[hp (kW)]	[hp (kW)]						1/2	3/4	1/1	1/2	3/4			1/1
60S 3 x 208 V	13.78 (10,3)	12.1 (9)	4	1785	D	37/	332	82	0.85	0.88	0.68	0.73	0.78	1.38 (0.0580)	166 (225)
61R 3 x 230/460 V	13.78 (10,3)	12.1 (9)	4	1785	D	32/16	279/192	82	0.85	0.88	0.72	0.77	0.82	1.38 (0.0580)	121 (164)
61M 3 x 575-600 V	13.78 (10,3)	12.1 (9)	4	1785	D	14-13/	155	82	0.85	0.88	0.69	0.74	0.79	1.38 (0.0580)	179 (243)

Pump data

Impeller diameter	Max. solids size	Outlet flange pressure (according to ASME B 16.5)	Max. installation depth
[in (mm)]	[in (mm)]	[PSI (PN)]	[ft (m)]
8.87 (225.42)	-	145 (PN 10)	66 (20)

SL/SE.A60.150.4.52H

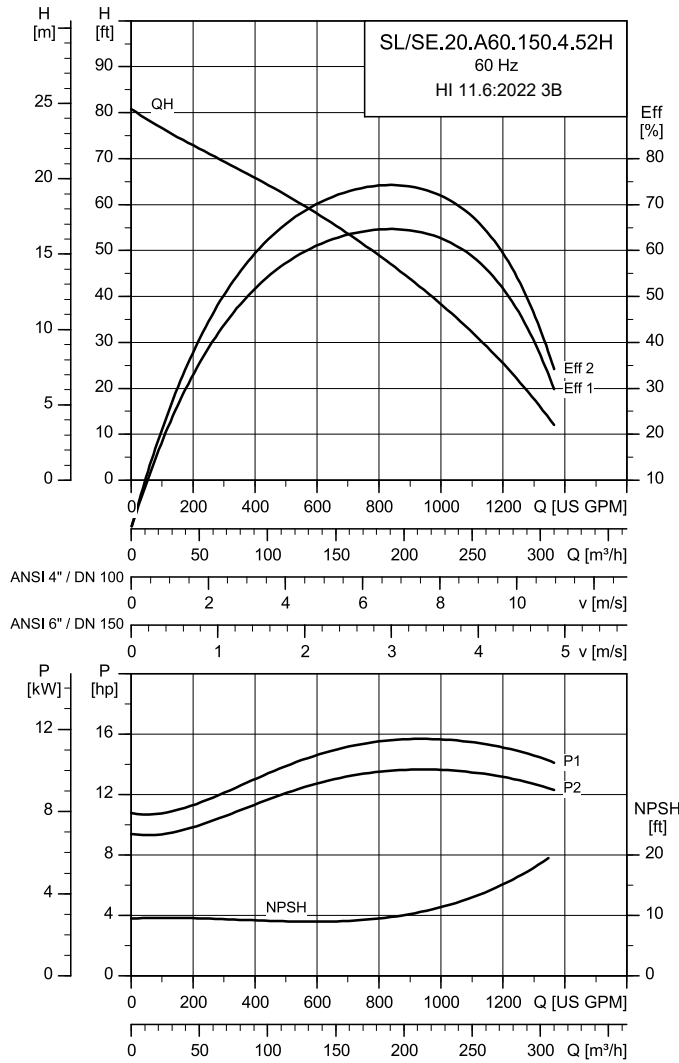

TM082752

Electrical data

Voltage variant	P1	P2	Number of poles	RPM	Starting method	I _N	I _{start}	η _{motor} [%]			Cos φ			Moment of inertia [lbf ² (kgm ²)]	Breakdown torque M _{max} [lbf*ft (Nm)]
								1/2	3/4	1/1	1/2	3/4	1/1		
	[hp (kW)]	[hp (kW)]				[A]	[A]								
60S 3 x 208 V	16.65 (12,4)	14.8 (11)	4	1782	D	43/	332	84	0.87	0.89	0.70	0.76	0.82	1.38 (0.058)	166 (225)
61R 3 x 230/460 V	16.65 (12,4)	14.8 (11)	4	1782	D	37/19	279/192	84	0.87	0.89	0.74	0.80	0.86	1.38 (0.058)	121 (164)
61M 3 x 575-600 V	16.65 (12,4)	14.8 (11)	4	1782	D	16-15/	155	84	0.87	0.89	0.71	0.77	0.83	1.38 (0.058)	179 (243)

Pump data

Impeller diameter	Max. solids size	Outlet flange pressure (according to ASME B 16.5)		Max. installation depth
[in (mm)]	[in (mm)]	[PSI (PN)]		[ft (m)]
9.41 (239)	-	145 (PN 10)		66 (20)

SL/SE.A60.175.4.52H

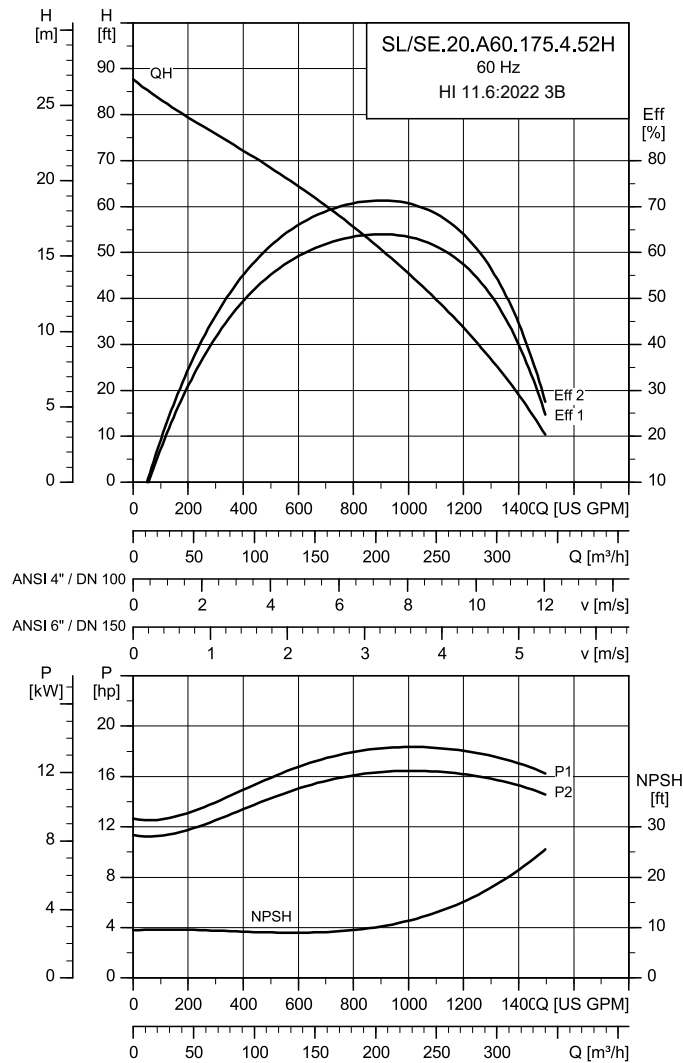

TM082753

Electrical data

Voltage variant	P1	P2	Number of poles	RPM	Starting method	I _N	I _{start}	η _{motor} [%]			Cos φ			Moment of inertia [lbft ² (kgm ²)]	Breakdown torque M _{max} [lbft (Nm)]
								1/2	3/4	1/1	1/2	3/4	1/1		
	[hp (kW)]	[hp (kW)]				[A]	[A]								
60S 3 x 208 V	19.32 (14,4)	17.4 (13)	4	1785	D	50/	420	86	0.89	0.9	0.64	0.75	0.81	1.78 (0.075)	260 (353)
61R 3 x 230/460 V	19.32 (14,4)	17.4 (13)	4	1785	D	44/22	420/290	86	0.89	0.9	0.66	0.77	0.83	1.78 (0.075)	184 (249)
61M 3 x 575-600 V	19.32 (14,4)	17.4 (13)	4	1785	D	18-17/	207	86	0.89	0.9	0.66	0.77	0.83	1.78 (0.075)	144 (195)

Pump data

Impeller diameter	Max. solids size	Outlet flange pressure (according to ASME B 16.5)		Max. installation depth
[in (mm)]	[in (mm)]	[PSI (PN)]		[ft (m)]
9.78 (2485)	-	145 (PN 10)		66 (20)

SL/SE.A60.200.4.52H

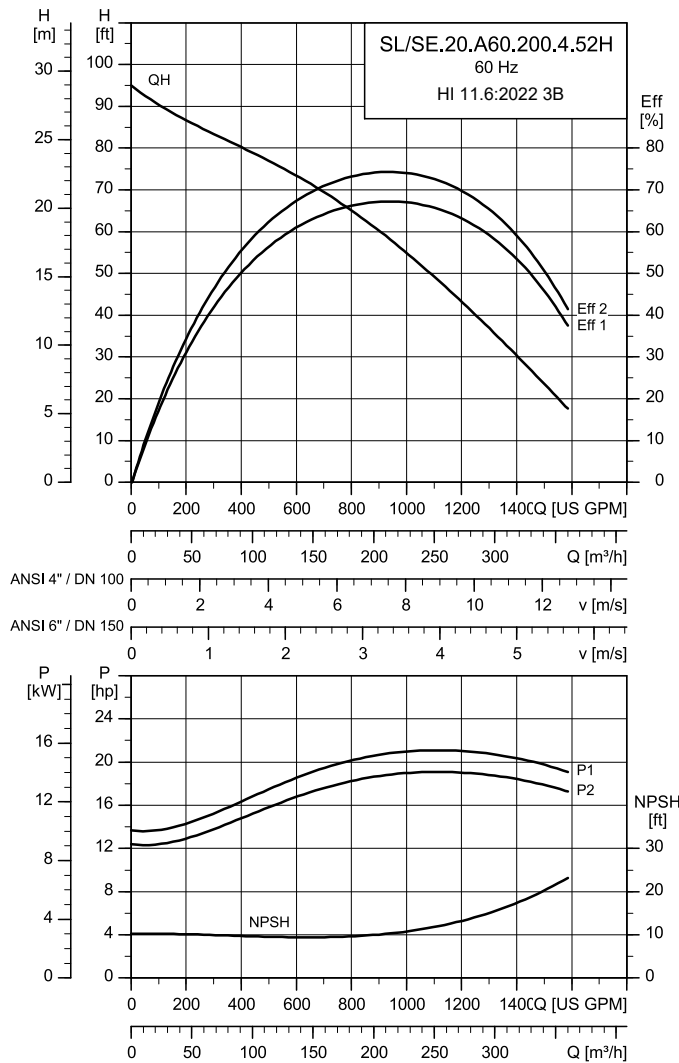

TM082754

Electrical data

Voltage variant	P1	P2	Number of poles	RPM	Starting method	I _N	I _{start}	η _{motor} [%]			Cos φ			Moment of inertia	Breakdown torque
								1/2	3/4	1/1	1/2	3/4	1/1	[lbft ² (kgm ²)]	M _{max}
	[hp (kW)]	[hp (kW)]				[A]	[A]								
60S 3 x 208 V	22.25 (16.6)	20.1 (15)	4	1783	D	57/	420	87	0.9	0.9	0.68	0.78	0.82	1.78 (0.075)	260 (353)
61R 3 x 230/460 V	22.25 (16.6)	20.1 (15)	4	1783	D	50/25	420/290	87	0.9	0.9	0.7	0.8	0.84	1.78 (0.075)	184 (249)
61M 3 x 575-600 V	22.25 (16.6)	20.1 (15)	4	1783	D	20-20/	207	87	0.9	0.9	0.7	0.8	0.84	1.78 (0.075)	144 (195)

Pump data

Impeller diameter	Max. solids size	Outlet flange pressure (according to ASME B 16.5)	Max. installation depth
[in (mm)]	[in (mm)]	[PSI (PN)]	[ft (m)]
10.06 (255.5)	-	145 (PN 10)	66 (20)

SL/SE.A60.245.4.52H

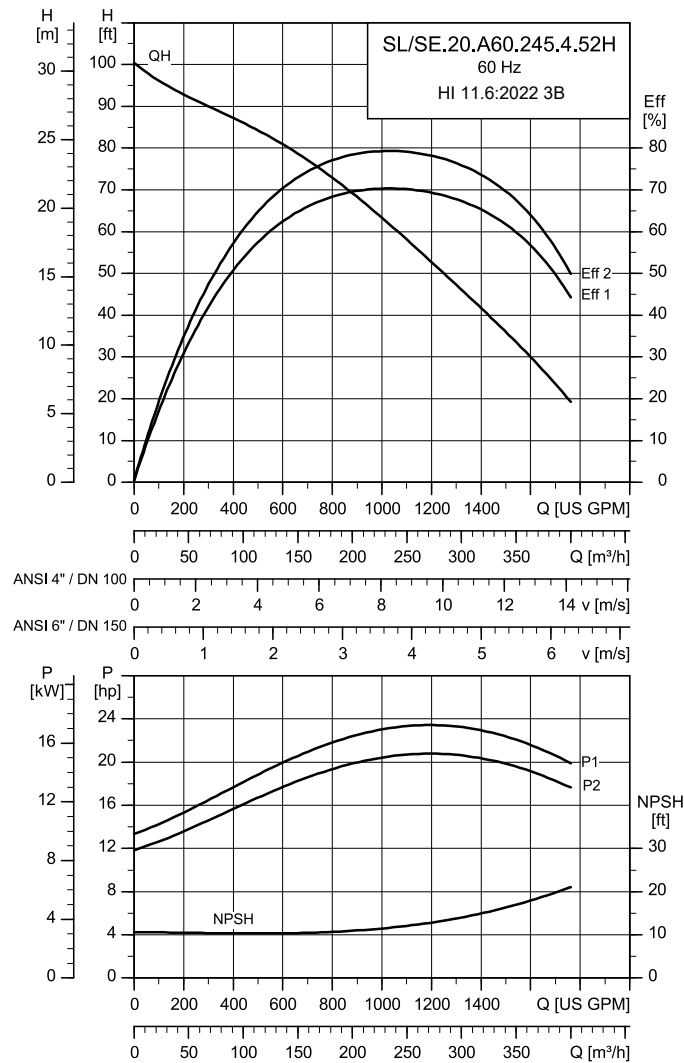

TM082755

Electrical data

Voltage variant	P1	P2	Number of poles	RPM	Starting method	I _N	I _{start}	η _{motor} [%]			Cos φ			Moment of inertia [lbft ² (kgm ²)]	Breakdown torque M _{max} [lbft (Nm)]
								1/2	3/4	1/1	1/2	3/4	1/1		
	[hp (kW)]	[hp (kW)]				[A]	[A]								
60S 3 x 208 V	27.14 (20.2)	24.1 (18)	4	1783	D	70/	830	87	0.88	0.89	0.66	0.74	0.81	1.78 (0.075)	371 (503)
61R 3 x 230/460 V	27.14 (20.2)	24.1 (18)	4	1783	D	64/32	534/363	87	0.88	0.89	0.66	0.74	0.81	1.78 (0.075)	260 (353)
61M 3 x 575-600 V	27.14 (20.2)	24.1 (18)	4	1783	D	26-25/	292	87	0.88	0.89	0.64	0.72	0.79	1.78 (0.075)	320 (434)

Pump data

Impeller diameter	Max. solids size	Outlet flange pressure (according to ASME B 16.5)	Max. installation depth
[in (mm)]	[in (mm)]	[PSI (PN)]	[ft (m)]
10.24 (260)	-	145 (PN 10)	66 (20)

SL/SE.A60.270.4.52H

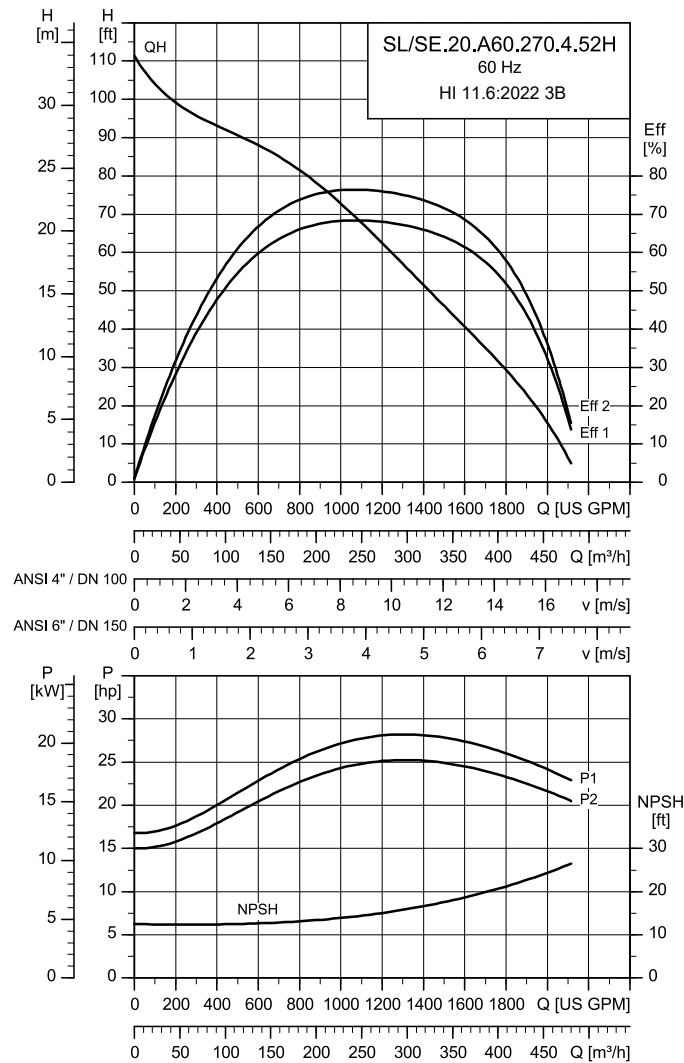

TM082756

Electrical data

Voltage variant	P1	P2	Number of poles	RPM	Starting method	I _N	I _{start}	η _{motor} [%]			Cos φ			Moment of inertia	Breakdown torque	
								1/2	3/4	1/1	1/2	3/4	1/1	[lbft ² (kgm ²)]	M _{max}	
	[hp (kW)]	[hp (kW)]				[A]	[A]									
60S	3 x 208 V	30.05 (22.4)	26.8 (20)	4	1782	D	76/	830	88	0.88	0.89	0.68	0.77	0.83	1.78 (0.075)	371 (503)
61R	3 x 230/460 V	30.05 (22.4)	26.8 (20)	4	1782	D	68/34	534/363	88	0.88	0.89	0.68	0.77	0.83	1.78 (0.075)	260 (353)
61M	3 x 575-600 V	30.05 (22.4)	26.8 (20)	4	1782	D	28-27/	292	88	0.88	0.89	0.66	0.75	0.81	1.78 (0.075)	320 (434)

Pump data

Impeller diameter	Max. solids size	Outlet flange pressure (according to ASME B 16.5)	Max. installation depth
[in (mm)]	[in (mm)]	[PSI (PN)]	[ft (m)]
10.9 (276.8)	-	145 (PN 10)	66 (20)

SL/SE.A60.300.4.52H

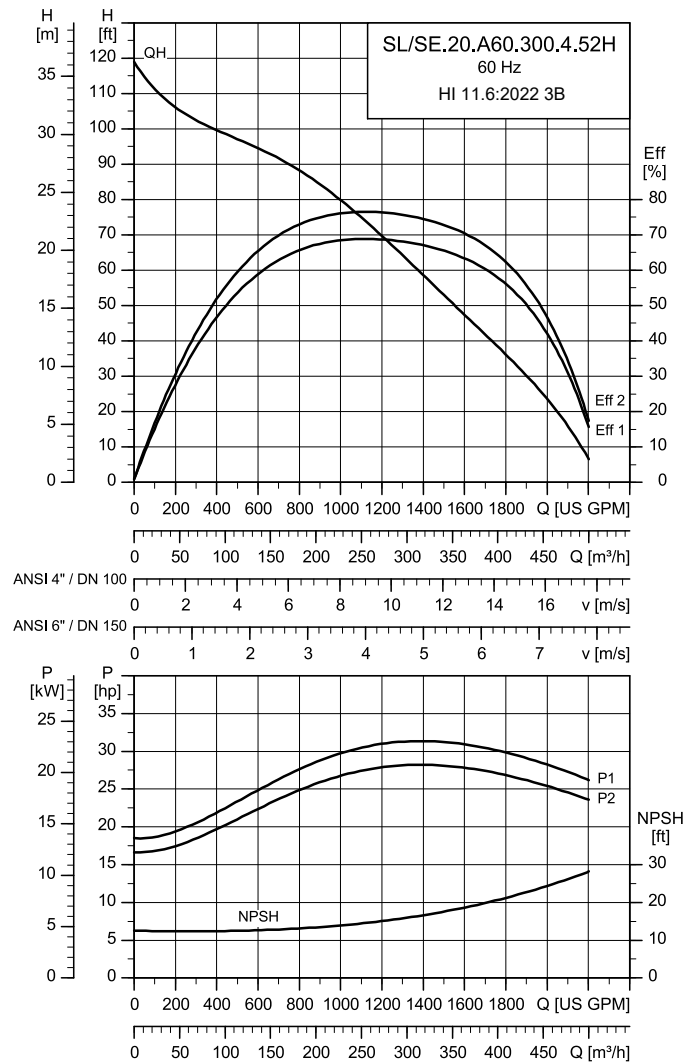

TM082757

Electrical data

Voltage variant	P1	P2	Number of poles	RPM	Starting method	I_N	I_{start}	η_{motor} [%]			$\cos \phi$			Moment of inertia	Breakdown torque M_{max}	
								1/2	3/4	1/1	1/2	3/4	1/1	[lbft^2 (kgm^2)]	[$\text{lbft} \cdot \text{ft}$ (Nm)]	
60S	3 x 208 V	32.93 (24.6)	29.5 (22)	4	1779	D	81/	830	88	0.89	0.9	0.7	0.79	0.84	1.78 (0.075)	371 (503)
61R	3 x 230/460 V	32.93 (24.6)	29.5 (22)	4	1779	D	73/37	534/363	88	0.89	0.9	0.7	0.79	0.84	1.78 (0.075)	260 (353)
61M	3 x 575-600 V	32.93 (24.6)	29.5 (22)	4	1779	D	30-29/	292	88	0.89	0.9	0.68	0.77	0.82	1.78 (0.075)	320 (434)

Pump data

Impeller diameter	Max. solids size	Outlet flange pressure (according to ASME B 16.5)	Max. installation depth
[in (mm)]	[in (mm)]	[PSI (PN)]	[ft (m)]
11.18 (284)	-	145 (PN 10)	66 (20)

SL/SE.A60.330.4.52H

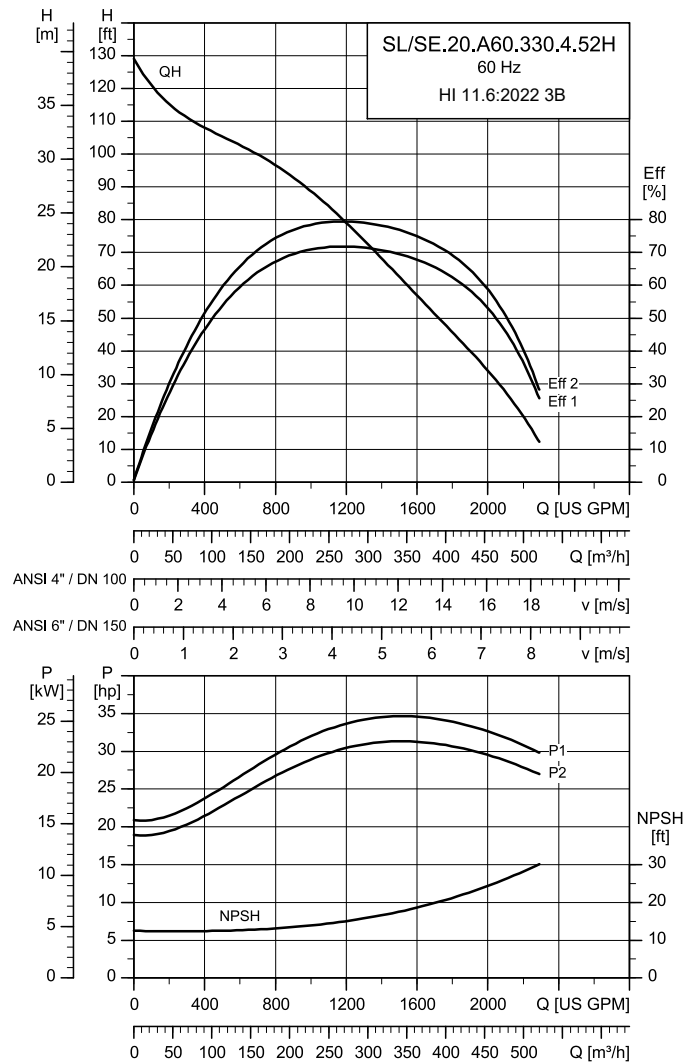

TM082758

Electrical data

Voltage variant	P1	P2	Number of poles	RPM	Starting method	I _N	I _{start}	η _{motor} [%]			Cos φ			Moment Breakdown of inertia M _{max}	
								1/2	3/4	1/1	1/2	3/4	1/1	[lbft ² (kgm ²)]	[lbft*ft (Nm)]
	[hp (kW)]	[hp (kW)]				[A]	[A]								
60S 3 x 208 V	36.51 (27.2)	32.9 (24.5)	4	1776	D	88/	830	88	0.89	0.9	0.72	0.81	0.86	1.78 (0.075)	371 (503)
61R 3 x 230/460 V	36.51 (27.2)	32.9 (24.5)	4	1776	D	80/40	534/363	88	0.89	0.9	0.72	0.81	0.86	1.78 (0.075)	260 (353)
61M 3 x 575-600 V	36.51 (27.2)	32.9 (24.5)	4	1776	D	33-32/	292	88	0.89	0.9	0.70	0.79	0.84	1.78 (0.075)	320 (434)

Pump data

Impeller diameter	Max. solids size	Outlet flange pressure (according to ASME B 16.5)	Max. installation depth
[in (mm)]	[in (mm)]	[PSI (PN)]	[ft (m)]
11.46 (291)	-	145 (PN 10)	66 (20)

9. Accessories

Installation systems

Horizontal stands for SE Range 52

- horizontal base stand with bolts and nuts.
- steel, epoxy-coated.



Pump type	Pressure range	Pump inlet	Pump outlet	Product number
SEV.XX.A30	H	ANSI 4"	ANSI 3"	99867049
SE/SE1.XX.A40	S	ANSI 4"	ANSI 4"	99867049
	H	ANSI 6"	ANSI 4"	99867050
SE/SE1.XX.A60	S	ANSI 6"	ANSI 6"	99867050
	H	ANSI 6"	ANSI 6"	99867050
SE1.XX.A80	M	ANSI 8"	ANSI 8"	99867461
SE2.XX.A100	L	ANSI 10"	ANSI 10"	99867473
SE2.XX.A120	E	ANSI 12"	ANSI 12"	99867475

TM088229

Vertical stands for SE Range 52 pumps up to 20 hp

Vertical base stand with bolts and flange seal.

Material variants:

- steel, epoxy-coated
- stainless steel

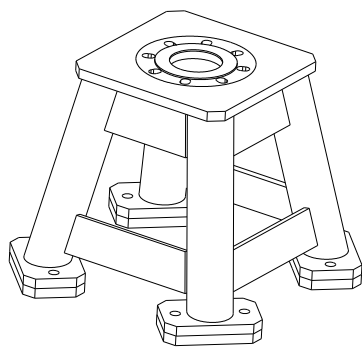

Pump type	Pressure range	Pump inlet	Pump outlet	Product number
				Steel
SEV.XX.A30	H	ANSI 4"	ANSI 3"	92593728
SE/SE1.XX.A40	S	ANSI 4"	ANSI 4"	92593728
	H	ANSI 6"	ANSI 4"	92593750
SE/SE1.XX.A60	S	ANSI 6"	ANSI 6"	92593750
	H	ANSI 6"	ANSI 6"	92593750
SE1.XX.A80	M	ANSI 8"	ANSI 8"	92593742
SE2.XXX.A100	L	ANSI 10"	ANSI 10"	92593764
SE2.XXX.A120	E	ANSI 12"	ANSI 12"	92593745

TM084845

Inlet bend with cleaning hole

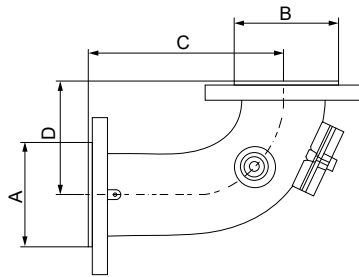

TM089855

Cast iron inlet bend with cleaning hole, 125 LB flanges with slotted holes.

Pump type	Dimensions [in]				Bend inlet	Bend outlet	Pump inlet	Product number
	A	B	C	D				
SE/SE1.XX.A40	9"	9"	11.5"	6.5"	ANSI 4"	ANSI 4"	ANSI 4"	92654455
	11"	9"	14"	7.5"	ANSI 6"	ANSI 4"	ANSI 4"	92663148
SE/SE1.XX.A60	11"	11"	11.5"	11.5"	ANSI 6"	ANSI 6"	ANSI 6"	92663151
	13.5"	11"	14"	8"	ANSI 8"	ANSI 6"	ANSI 6"	92663156
SE1.XXX.A80	16"	13.5"	16"	10"	ANSI 10	ANSI 8"	ANSI 8"	92663176
SE2.XXX.A100	16"	16"	18"	11"	ANSI 10"	ANSI 10"	ANSI 10"	92663180
SE2.XXX.A120	19"	19"	20"	14"	ANSI 12"	ANSI 12"	ANSI 12"	92663187

Base plate for SE Range 52 pumps

Epoxy-coated steel base plate with bolts and flange seal.



ANSI Standard recommends that for 20 hp (15 kW) and above, pumps should be installed on concrete foundation.

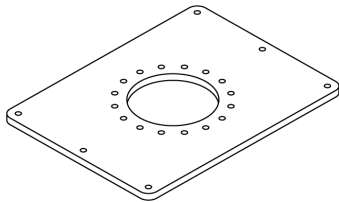

TM032015

Pump type	Pressure range	Pump inlet	Pump outlet	Product number	
				Steel	Stainless steel
SEV.XX.A30	H	ANSI 4"	ANSI 3"	92837287	96090110
SE/SE1.XX.A40	S	ANSI 4"	ANSI 4"	92837287	96090110
	H	ANSI 6"	ANSI 4"	92837293	96835614
SE/SE1.XX.A60	S	ANSI 6"	ANSI 6"	92837293	96835614
	H	ANSI 6"	ANSI 6"	92837293	96835614
SE1.XXX.A80	M	ANSI 8"	ANSI 8"	92837295	96090119
SE2.XXX.A100	L	ANSI 10"	96857815	96308240	
SE2.XXX.A120	E	ANSI 12"	96857816	96308241	

Submerged, vertical, permanent on auto-coupling

Auto-coupling system ANSI 3" - ANSI 12"

- complete auto-coupling system with guide shoe, base unit, upper guide-rail holder (UGRH), bolts, nuts and gaskets.

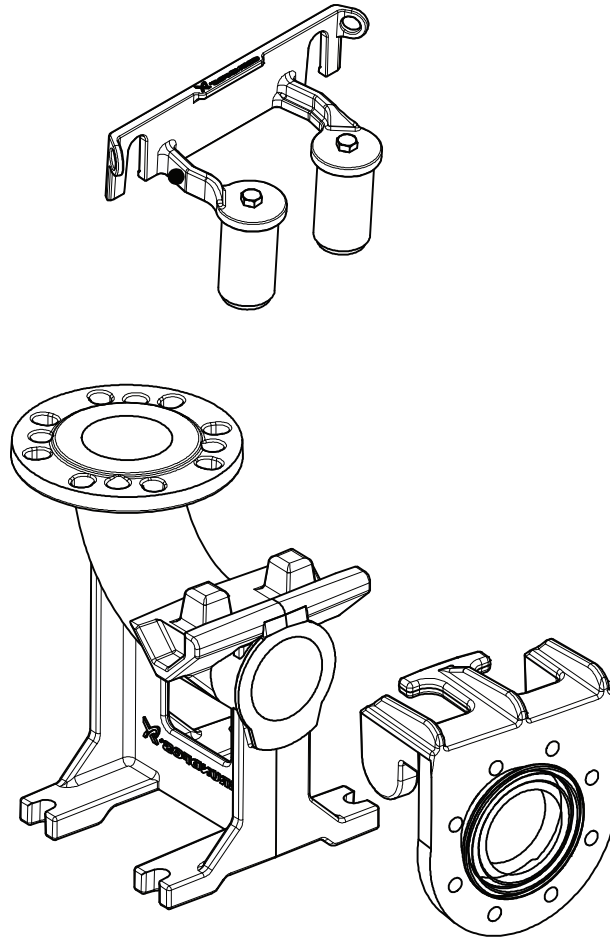

TM053872

Note: If the guide rails exceed 19.7 ft, consider using intermediate guide-rail holders (IGRH) to support the system.

Pump type	Pressure range	Pump inlet	Pump outlet	Auto-coupling inlet	Auto-coupling outlet	Product number
						Cast iron
SEV/SLV.XX.A30	H	ANSI 4"	ANSI 3"	ANSI 3"	ANSI 4"	97626239
SE/SL/SE1/SL1.XX.A40	S	ANSI 4"	ANSI 4"	ANSI 4"	ANSI 4"	97626238
	H	ANSI 6"	ANSI 4"	ANSI 4"	ANSI 6"	97626241
SE/SL/SE1/SL1.XX.A60	S	ANSI 6"	ANSI 6"	ANSI 6"	ANSI 6"	97695489 ³²⁾
	H	ANSI 6"	ANSI 6"	ANSI 6"	ANSI 6"	97695489 ³³⁾
SE1/SL1.XX.A80	M	ANSI 8"	ANSI 8"	ANSI 8"	ANSI 8"	97506541
SE2/SL2.XXX.A100	L	ANSI 10"	ANSI 10"	ANSI 10"	ANSI 10"	92886611
SE2/SL2.XXX.A120	E	ANSI 12"	ANSI 12"	ANSI 12"	ANSI 12"	92886613

³²⁾ For 2" guide rails.

³³⁾ For 3" guide rails.

Auto-coupling spare parts ANSI 3" - ANSI 12"

Intermediate guide-rail brackets IGRH / UGRH

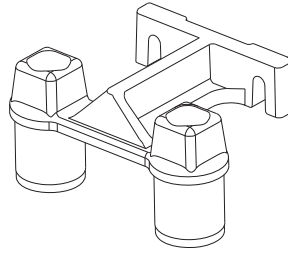
Note: The size of the intermediate guide-rail bracket depends on the outlet pipe dimensions. U-bolt is not included.

TM062841

Pump type	Pressure range	Pump inlet	Pump outlet	Product number	
				IGRH	UGRH
SEV/SLV.XX.A30	H	ANSI 4"	ANSI 3"	96825142	97904181
SE/SL/SE1/SL1.XX.A40	S	ANSI 4"	ANSI 4"	96825161	97904181
	H	ANSI 6"	ANSI 4"	96829331	97904181
SE/SL/SE1/SL1.XX.A60	S	ANSI 6"	ANSI 6"	96829331	96825172
	H	ANSI 6"	ANSI 6"	96829331	97918997
	M	ANSI 8"	ANSI 8"	97918997	97918997
SE2/SL2.XXX.A100	L	ANSI 10"	ANSI 10"	97918997	97918997
SE2/SL2.XXX.A120	E	ANSI 12"	ANSI 12"		

Auto-coupling spare parts ANSI 3" - ANSI 12"

Complete guide shoe

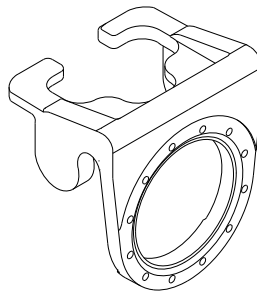

TM068850

Pump type	Pressure range	Pump inlet	Pump outlet	Product number
SEV/SLV.XX.A30	H	ANSI 4"	ANSI 3"	97661984
SE/SL/SE1/SL1.XX.A40	S	ANSI 4"	ANSI 4"	96046814
	H	ANSI 6"	ANSI 4"	97661985
SE/SL/SE1/SL1.XX.A60	S	ANSI 6"	ANSI 6"	96590097
	H	ANSI 6"	ANSI 6"	96590097
SE1/SL1.XXX.A80	M	ANSI 8"	ANSI 8"	97506421
SE2/SL2.XXX.A100	L	ANSI 10"	ANSI 10"	98822229
SE2/SL2.XXX.A120	E	ANSI 12"	ANSI 12"	96255574

Lifting chain

- complete, certified lifting chain for all pump types.
- maximum load: 1764 lb (800 kg)
- material variants
 - galvanised steel
 - stainless steel, AISI 316 Ti (EN 1.4571).



TM026126

Material	Length [ft (m)]	Product number
Galvanised steel	6.6 (2)	98425759
	13.1 (4)	98425760
	20.0 (6)	98425781
	26.2 (8)	98425782
	33.0 (10)	98425783
Stainless steel	6.6 (2)	98425796
	13.1 (4)	98425797
	20.0 (6)	98425798
	26.2 (8)	98425799
	33.0 (10)	98425800

Adaptors for SE/SL Range 52 pumps

Adaptor for Flygt type auto-couplings

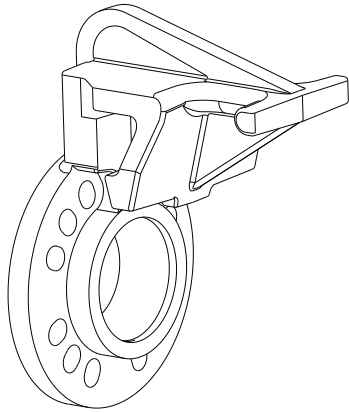

Pump type	Pressure range	Pump inlet	Pump outlet	Adaptor outlet	Product number
SEV/SLV.XX.A30	H	ANSI 3"	ANSI 3"	ANSI 3"/3"	97900652
SEV/SLV.XX.A30	S	ANSI 3"	ANSI 3"	ANSI 3"/4"	97903560
SE/SL/SE1/SL1.XX.A40	H/S	ANSI 4"	ANSI 4"	ANSI 4"/4"	97905213
SE/SL/SE1/SL1.XX.A40	H/S	ANSI 4"	ANSI 4"	ANSI 4"/6"	97903622
SE/SL/SE1/SL1.XX.A60	H/S	ANSI 6"	ANSI 6"		
SE1/SL1.XXX.A60	M	ANSI 6"	ANSI 6"	ANSI 6"/6"	98061131
SE1/SL1.XXX.A60	L	ANSI 6"	ANSI 6"	ANSI 6"/6"	98061107*
SE1/SL1.XXX.A80	E	ANSI 8"	ANSI 8"	ANSI 8"/8"	98377111*
SE2/SL2.XXX.A100	L	ANSI 10"	ANSI 10"	ANSI 10"/10"	98377112*
SE2/SL2.XXX.A120	E	ANSI 12"	ANSI 12"	ANSI 12"/12"	98419130*

TM069949

*For 3" guide pipes

10. Dimensions

Recommendation for pump foundations

Note: This applies only for pumps above 20 hp. According to the ANSI/HI 1.4 standard, the following pump foundations are recommended.

All rotating equipment generates vibration when a mass, such as an impeller or rotor, is turning at high speeds. Proper installation and anchorage of Grundfos pumps and installation accessories are critical to limit vibrations and achieving reliable, smooth installation. All mechanically connected pipes, fittings and supports of the pump are part of a single system.

The rotating mass of the entire pump together with the forces from the motor and hydraulics generate disturbances related to the speed of the motor. Unbalance and impeller vane pass in hydraulics are the two most important types of frequencies affecting vibration. When these frequencies coincide with a natural frequency of the entire mechanical system, the vibration level increases substantially.

Grundfos pumps are designed and produced according to the highest quality standards. The method and grade of balancing is specified by the manufacturer in order to achieve acceptable vibration levels. Although the pump itself can withstand rather high vibration levels under running conditions without considerable lifetime reduction, the pipes and supportive structure may suffer and crack if vibration levels are too high. Furthermore, noticeable noise levels might be generated.

The occurrence of high vibration levels is increased in variable speed applications where the pump is operated over a range of speeds rather than at a single constant speed. Most variable speed drives provide the possibility to exclude certain frequencies.

To ensure acceptable vibration levels in the field, all parts of the system must be sufficiently stiff and firmly anchored to minimize vibrations:

- The foundation and concrete must have adequate strength to support the weight of the pump including accessories, the weight of the liquid passing through the pump and the forces generated.
- The mass of the concrete foundation must be at least three to five times the mass of the supported equipment and must have sufficient rigidity to withstand the axial, transverse and torsional loads generated by these machines.

- The foundation must be 6 in (15 cm) wider than the base plate.
- The concrete used in the foundation must have a minimum tensile strength of 363 PSI (250 N/cm²).
- Use epoxy grout and screws to fix the pump base plate to the foundation.

Pull-out strengths for bolts and anchor bolts

Submerged installation with and without cooling jacket on auto-coupling:

Auto-coupling base unit	Bolts	Pull-out resistance [kip (kN)]
ANSI 4"	4 x 5/8" (M16)	1.1 (5)
ANSI 6"		1.8 (8)
ANSI 8"		3.6 (16)
ANSI 10"	4 x 1" (M24)	6.7 (30)
ANSI 12"		9.0 (40)

Dry vertical and horizontal installation:

Dry horizontal installation	Anchor bolts	Pull-out resistance [kip (kN)]
ANSI 4"	8 x 5/8" (M16)	1.1 (5)
ANSI 6"		4.0 (18)
ANSI 8"		4.0 (18)
ANSI 10"	12 x 3/4" (M20)	4.0 (18)
ANSI 12"		4.0 (18)

Dry vertical installation	Anchor bolts	Pull-out resistance [kip (kN)]
ANSI 4"	8 x 3/4" (M20)	1.1 (5)
ANSI 6"		
ANSI 8"		
ANSI 10"		4.0 (18)
ANSI 12"		

Pump installation dimensions

Submerged installation

Installation on Auto-coupling

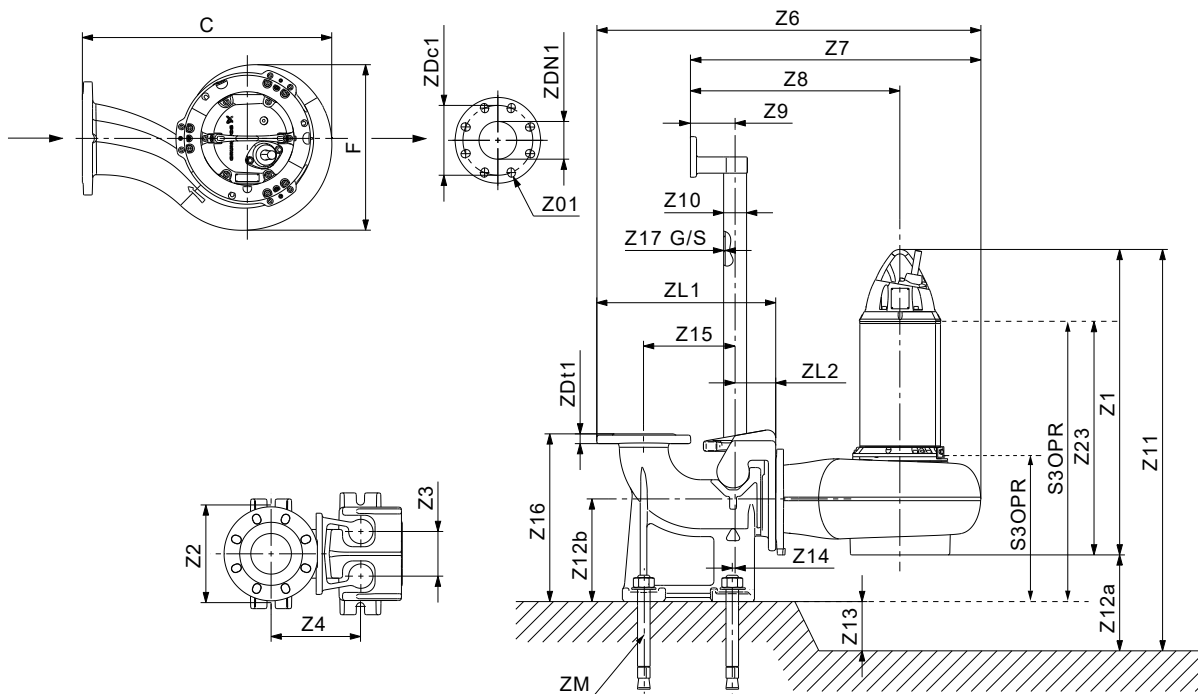

TM052579

Auto-coupling dimensions

Pos.	Description
1	Minimum liquid level (S3OPR) for submersible installation without cooling jacket, SL pumps (Standard and Ex)
2	Minimum liquid level (S3OPR) for submersible installation with cooling jacket, SE pumps (Standard and Ex)

SE/SE1/SE2/SEV [in (mm)] (part 1)

Pump type	C	F	Z01 [Qty x mm]	Z1	Z2	Z3	Z4	Z6	Z7	Z8	Z9	Z10	Z11	Z12a	Z12b
SE1.30.A40.175.2.52S	18.8 (478)	15.2 (386)	8 X M20	44.7 (1136)	9.1 (230)	4.3 (110)	8.7 (220)	36.3 (921)	27.4 (695)	19.8 (502)	4.3 (110)	2.4 (60)	49.1 (1246)	4.3 (110)	9.4 (240)
SE.A40.175.2.52S	18.7 (476)	15 (382)	8 X M20	44.9 (1140)	9.1 (230)	4.3 (110)	8.7 (220)	36.2 (919)	27.3 (693)	19.8 (502)	4.3 (110)	2.4 (60)	48.5 (1232)	3.6 (92)	9.4 (240)
SE1.30.A40.200.2.52S	18.8 (478)	15.2 (386)	8 X M20	44.7 (1136)	9.1 (230)	4.3 (110)	8.7 (220)	36.3 (921)	27.4 (695)	19.8 (502)	4.3 (110)	2.4 (60)	49.1 (1246)	4.3 (110)	9.4 (240)
SE.A40.200.2.52S	18.7 (476)	15 (382)	8 X M20	44.9 (1140)	9.1 (230)	4.3 (110)	8.7 (220)	36.2 (919)	27.3 (693)	19.8 (502)	4.3 (110)	2.4 (60)	48.5 (1232)	3.6 (92)	9.4 (240)
SE1.30.A40.230.2.52S	18.8 (478)	15.2 (386)	8 X M20	44.7 (1136)	9.1 (230)	4.3 (110)	8.7 (220)	36.3 (921)	27.4 (695)	19.8 (502)	4.3 (110)	2.4 (60)	49.1 (1246)	4.3 (110)	9.4 (240)
SE.A40.230.2.52S	18.7 (476)	15 (382)	8 X M20	44.9 (1140)	9.1 (230)	4.3 (110)	8.7 (220)	36.2 (919)	27.3 (693)	19.8 (502)	4.3 (110)	2.4 (60)	48.5 (1232)	3.6 (92)	9.4 (240)
SE1.30.A40.250.2.52S	18.8 (478)	15.2 (386)	8 X M20	44.7 (1136)	9.1 (230)	4.3 (110)	8.7 (220)	36.3 (921)	27.4 (695)	19.8 (502)	4.3 (110)	2.4 (60)	49.1 (1246)	4.3 (110)	9.4 (240)
SE.A40.250.2.52S	18.7 (476)	15 (382)	8 X M20	44.9 (1140)	9.1 (230)	4.3 (110)	8.7 (220)	36.2 (919)	27.3 (693)	19.8 (502)	4.3 (110)	2.4 (60)	48.5 (1232)	3.6 (92)	9.4 (240)
SE1.30.A40.120.4.52H	23.2 (590)	16.8 (427)	8 X M20	45.6 (1159)	9.1 (230)	4.3 (110)	8.7 (220)	40.7 (1033)	31.8 (807)	23.5 (597)	4.3 (110)	2.4 (60)	51.1 (1299)	5.5 (140)	9.4 (240)
SE.A40.120.4.52H	23.2 (590)	16.8 (427)	8 X M20	45.6 (1158)	9.1 (230)	4.3 (110)	8.7 (220)	40.7 (1033)	31.8 (807)	3 (597)	4.3 (110)	2.4 (60)	51.1 (1298)	5.5 (140)	9.4 (240)
SE1.30.A40.150.4.52H	23.2 (590)	16.8 (427)	8 X M20	45.6 (1159)	9.1 (230)	4.3 (110)	8.7 (220)	40.7 (1033)	31.8 (807)	23.5 (597)	4.3 (110)	2.4 (60)	51.1 (1299)	5.5 (140)	9.4 (240)
SE.A40.150.4.52H	23.2 (590)	16.8 (427)	8 X M20	45.6 (1158)	9.1 (230)	4.3 (110)	8.7 (220)	40.7 (1033)	31.8 (807)	23.5 (597)	4.3 (110)	2.4 (60)	51.1 (1298)	5.5 (140)	9.4 (240)
SE1.30.A40.175.4.52H	23.2 (590)	16.8 (427)	8 X M20	45.6 (1159)	9.1 (230)	4.3 (110)	8.7 (220)	40.7 (1033)	31.8 (807)	23.5 (597)	4.3 (110)	2.4 (60)	51.1 (1299)	5.5 (140)	9.4 (240)
SE.A40.175.4.52H	23.2 (590)	16.8 (427)	8 X M20	45.6 (1158)	9.1 (230)	4.3 (110)	8.7 (220)	40.7 (1033)	31.8 (807)	23.5 (597)	4.3 (110)	2.4 (60)	51.1 (1298)	5.5 (140)	9.4 (240)
SE1.30.A40.200.4.52H	23.2 (590)	16.8 (427)	8 X M20	45.6 (1159)	9.1 (230)	4.3 (110)	8.7 (220)	40.7 (1033)	31.8 (807)	23.5 (597)	4.3 (110)	2.4 (60)	51.1 (1299)	5.5 (140)	9.4 (240)
SE.A40.200.4.52H	23.2 (590)	16.8 (427)	8 X M20	45.6 (1158)	9.1 (230)	4.3 (110)	8.7 (220)	40.7 (1033)	31.8 (807)	23.5 (597)	4.3 (110)	2.4 (60)	51.1 (1298)	5.5 (140)	9.4 (240)
SE1.35.A40.245.4.52H	24 (609)	18.1 (460)	8 X M20	45.7 (1160)	9.1 (230)	4.3 (110)	8.7 (220)	41.4 (1052)	32.5 (826)	23.5 (597)	4.3 (110)	2.4 (60)	51.2 (1300)	5.5 (140)	9.4 (240)
SE.A40.245.4.52H	24 (609)	18.2 (462)	8 X M20	45.7 (1161)	9.1 (230)	4.3 (110)	8.7 (220)	41.4 (1052)	32.5 (826)	23.5 (597)	4.3 (110)	2.4 (60)	51.2 (1301)	5.5 (140)	9.4 (240)
SE1.35.A40.270.4.52H	24 (609)	18.1 (460)	8 X M20	44.3 (1126)	9.1 (230)	4.3 (110)	8.7 (220)	41.4 (1052)	32.5 (826)	23.5 (597)	4.3 (110)	2.4 (60)	49.8 (1266)	5.5 (140)	9.4 (240)
SE.A40.270.4.52H	24 (609)	18.2 (462)	8 X M20	45.7 (1161)	9.1 (230)	4.3 (110)	8.7 (220)	41.4 (1052)	32.5 (826)	23.5 (597)	4.3 (110)	2.4 (60)	51.2 (1301)	5.5 (140)	9.4 (240)
SE1.35.A40.300.4.52H	24 (609)	18.1 (460)	8 X M20	44.3 (1126)	9.1 (230)	4.3 (110)	8.7 (220)	41.4 (1052)	32.5 (826)	23.5 (597)	4.3 (110)	2.4 (60)	49.8 (1266)	5.5 (140)	9.4 (240)
SE.A40.300.4.52H	24 (609)	18.2 (462)	8 X M20	45.7 (1161)	9.1 (230)	4.3 (110)	8.7 (220)	41.4 (1052)	32.5 (826)	23.5 (597)	4.3 (110)	2.4 (60)	51.2 (1301)	5.5 (140)	9.4 (240)
SE1.35.A40.330.4.52H	24 (609)	18.1 (460)	8 X M20	45.7 (1160)	9.1 (230)	4.3 (110)	8.7 (220)	41.4 (1052)	32.5 (826)	23.5 (597)	4.3 (110)	2.4 (60)	51.2 (1300)	5.5 (140)	9.4 (240)
SE.A40.330.4.52H	24 (609)	18.2 (462)	8 X M20	45.7 (1161)	9.1 (230)	4.3 (110)	8.7 (220)	41.4 (1052)	32.5 (826)	23.5 (597)	4.3 (110)	2.4 (60)	51.2 (1301)	5.5 (140)	9.4 (240)
SE1.30.A60.120.4.52H	21.9 (557)	16.7 (424)	8 X M25	45.6 (1159)	11.8 (300)	4.8 (123)	11 (280)	43.7 (1109)	31.3 (796)	23.2 (589)	4.3 (110)	3.5 (89)	49.8 (1264)	4.1 (105)	10.8 (275)
SE.A60.120.4.52H	22 (558)	16.7 (424)	8 X M25	45.6 (1158)	11.8 (300)	4.8 (123)	11 (280)	43.7 (1110)	31.4 (797)	23.2 (589)	4.3 (110)	3.5 (89)	49.7 (1263)	4.1 (105)	10.8 (275)
SE1.30.A60.150.4.52H	21.9 (557)	16.7 (424)	8 X M25	45.6 (1159)	11.8 (300)	4.8 (123)	11 (280)	43.7 (1109)	31.3 (796)	23.2 (589)	4.3 (110)	3.5 (89)	49.8 (1264)	4.1 (105)	10.8 (275)

Pump type	C	F	Z01 [Qty x mm]	Z1	Z2	Z3	Z4	Z6	Z7	Z8	Z9	Z10	Z11	Z12a	Z12b
SE.A60.150.4.52H	22 (558)	16.7 (424)	8 X M25	45.6 (1158)	11.8 (300)	4.8 (123)	11 (280)	43.7 (1110)	31.4 (797)	23.2 (589)	4.3 (110)	3.5 (89)	49.7 (1263)	4.1 (105)	10.8 (275)
SE1.30.A60.175.4.52H	21.9 (557)	16.7 (424)	8 X M25	45.6 (1159)	11.8 (300)	4.8 (123)	11 (280)	43.7 (1109)	31.3 (796)	23.2 (589)	4.3 (110)	3.5 (89)	49.8 (1264)	4.1 (105)	10.8 (275)
SE.A60.175.4.52H	22 (558)	16.7 (424)	8 X M25	45.6 (1158)	11.8 (300)	4.8 (123)	11 (280)	43.7 (1110)	31.4 (797)	23.2 (589)	4.3 (110)	3.5 (89)	49.7 (1263)	4.1 (105)	10.8 (275)
SE1.30.A60.200.4.52H	21.9 (557)	16.7 (424)	8 X M25	45.6 (1159)	11.8 (300)	4.8 (123)	11 (280)	43.7 (1109)	31.3 (796)	23.2 (589)	4.3 (110)	3.5 (89)	49.8 (1264)	4.1 (105)	10.8 (275)
SE.A60.200.4.52H	22 (558)	16.7 (424)	8 X M25	45.6 (1158)	11.8 (300)	4.8 (123)	11 (280)	43.7 (1110)	31.4 (797)	23.2 (589)	4.3 (110)	3.5 (89)	49.7 (1263)	4.1 (105)	10.8 (275)
SE1.35.A60.245.4.52H	23.8 (1157)	17.9 (454)	8 X M25	45.6 (1159)	11.8 (300)	4.8 (123)	11 (280)	6.2 (1157)	33.2 (844)	24.4 (619)	4.3 (110)	3.5 (89)	49.6 (1261)	4 (102)	10.8 (275)
SE.A60.245.4.52H	23.8 (1157)	17.9 (454)	8 X M25	45.7 (1161)	11.8 (300)	4.8 (123)	11 (280)	6.2 (1157)	33.2 (844)	24.4 (619)	4.3 (110)	3.5 (89)	49.7 (1263)	4 (102)	10.8 (275)
SE1.35.A60.270.4.52H	23.8 (1157)	17.9 (454)	8 X M25	45.6 (1159)	11.8 (300)	4.8 (123)	11 (280)	6.2 (1157)	33.2 (844)	24.4 (619)	4.3 (110)	3.5 (89)	49.6 (1261)	4 (102)	10.8 (275)
SE.A60.270.4.52H	23.8 (1157)	17.9 (454)	8 X M25	45.7 (1161)	11.8 (300)	4.8 (123)	11 (280)	6.2 (1157)	33.2 (844)	24.4 (619)	4.3 (110)	3.5 (89)	49.7 (1263)	4 (102)	10.8 (275)
SE1.35.A60.300.4.52H	23.8 (1157)	17.9 (454)	8 X M25	45.6 (1159)	11.8 (300)	4.8 (123)	11 (280)	6.2 (1157)	33.2 (844)	24.4 (619)	4.3 (110)	3.5 (89)	49.6 (1261)	4 (102)	10.8 (275)
SE.A60.300.4.52H	23.8 (1157)	17.9 (454)	8 X M25	45.7 (1161)	11.8 (300)	4.8 (123)	11 (280)	6.2 (1157)	33.2 (844)	24.4 (619)	4.3 (110)	3.5 (89)	49.7 (1263)	4 (102)	10.8 (275)
SE1.35.A60.330.4.52H	23.8 (1157)	17.9 (454)	8 X M25	45.6 (1159)	11.8 (300)	4.8 (123)	11 (280)	6.2 (1157)	33.2 (844)	24.4 (619)	4.3 (110)	3.5 (89)	49.6 (1261)	4 (102)	10.8 (275)
SE1.40.A80.120.4.52M	29 (737)	18.5 (470)	8 X M22	46.4 (1178)	16.9 (430)	7.9 (200)	21.1 (535)	59 (1498)	44.5 (1130)	35.2 (893)	6.7 (170)	3.5 (89)	51.9 (1318)	5.5 (140)	7.7 (196)
SE1.40.A80.150.4.52M	29 (737)	18.5 (470)	8 X M22	46.4 (1178)	16.9 (430)	7.9 (200)	21.1 (535)	59 (1498)	44.5 (1130)	35.2 (893)	6.7 (170)	3.5 (89)	51.9 (1318)	5.5 (140)	7.7 (196)
SE1.40.A80.175.4.52M	29 (737)	18.5 (470)	8 X M22	46.4 (1178)	16.9 (430)	7.9 (200)	21.1 (535)	59 (1498)	44.5 (1130)	35.2 (893)	6.7 (170)	3.5 (89)	51.9 (1318)	5.5 (140)	7.7 (196)
SE1.40.A80.200.4.52M	29 (737)	18.5 (470)	8 X M22	46.4 (1178)	16.9 (430)	7.9 (200)	21.1 (535)	59 (1498)	44.5 (1130)	35.2 (893)	6.7 (170)	3.5 (89)	51.9 (1318)	5.5 (140)	7.7 (196)
SE1.45.A80.245.4.52M	29.7 (755)	19.7 (500)	8 X M22	46.8 (1188)	16.9 (430)	7.9 (200)	21.1 (535)	59.7 (1516)	1.9 (1148)	35.2 (893)	6.7 (170)	3.5 (89)	52.3 (1328)	5.5 (140)	7.7 (196)
SE1.45.A80.270.4.52M	29.7 (755)	19.7 (500)	8 X M22	46.8 (1188)	16.9 (430)	7.9 (200)	21.1 (535)	59.7 (1516)	1.9 (1148)	35.2 (893)	6.7 (170)	3.5 (89)	52.3 (1328)	5.5 (140)	7.7 (196)
SE1.45.A80.300.4.52M	29.7 (755)	19.7 (500)	8 X M22	46.8 (1188)	16.9 (430)	7.9 (200)	21.1 (535)	59.7 (1516)	1.9 (1148)	35.2 (893)	6.7 (170)	3.5 (89)	52.3 (1328)	5.5 (140)	7.7 (196)
SE1.45.A80.330.4.52M	29.7 (755)	19.7 (500)	8 X M22	46.8 (1188)	16.9 (430)	7.9 (200)	21.1 (535)	59.7 (1516)	1.9 (1148)	35.2 (893)	6.7 (170)	3.5 (89)	52.3 (1328)	5.5 (140)	7.7 (196)
SE2.45.A100.150.4.52L	33.4 (849)	26.8 (680)	12 X M25	47.3 (1202)	18.5 (471)	7.9 (200)	22.2 (565)	64.7 (1644)	49 (1245)	35.3 (896)	6.7 (170)	3.5 (89)	52.8 (1342)	5.5 (140)	8.8 (224)
SE2.45.A100.175.4.52L	33.4 (849)	26.8 (680)	12 X M25	47.3 (1202)	18.5 (471)	7.9 (200)	22.2 (565)	64.7 (1644)	49 (1245)	35.3 (896)	6.7 (170)	3.5 (89)	52.8 (1342)	5.5 (140)	8.8 (224)
SE2.45.A100.200.4.52L	33.4 (849)	26.8 (680)	12 X M25	47.3 (1202)	18.5 (471)	7.9 (200)	22.2 (565)	64.7 (1644)	49 (1245)	35.3 (896)	6.7 (170)	3.5 (89)	52.8 (1342)	5.5 (140)	8.8 (224)
SE2.45.A100.245.4.52L	33.4 (849)	26.8 (680)	12 X M25	47.3 (1202)	18.5 (471)	7.9 (200)	22.2 (565)	64.7 (1644)	49 (1245)	35.3 (896)	6.7 (170)	3.5 (89)	52.8 (1342)	5.5 (140)	8.8 (224)
SE2.45.A100.270.4.52L	33.4 (849)	26.8 (680)	12 X M25	47.3 (1202)	18.5 (471)	7.9 (200)	22.2 (565)	64.7 (1644)	49 (1245)	35.3 (896)	6.7 (170)	3.5 (89)	52.8 (1342)	5.5 (140)	8.8 (224)
SE2.45.A100.300.4.52L	33.4 (849)	26.8 (680)	12 X M25	47.3 (1202)	18.5 (471)	7.9 (200)	22.2 (565)	64.7 (1644)	49 (1245)	35.3 (896)	6.7 (170)	3.5 (89)	52.8 (1342)	5.5 (140)	8.8 (224)
SE2.45.A100.330.4.52L	33.4 (849)	26.8 (680)	12 X M25	47.3 (1202)	18.5 (471)	7.9 (200)	22.2 (565)	64.7 (1644)	49 (1245)	35.3 (896)	6.7 (170)	3.5 (89)	52.8 (1342)	5.5 (140)	8.8 (224)

Pump type	C	F	Z01 [Qty x mm]	Z1	Z2	Z3	Z4	Z6	Z7	Z8	Z9	Z10	Z11	Z12a	Z12b
SE2.45.A100.110.6.52E	33.4 (849)	26.8 (680)	12 X M25	47.3 (1202)	18.5 (471)	7.9 (200)	22.2 (565)	64.7 (1644)	49 (1245)	35.3 (896)	6.7 (170)	3.5 (89)	52.8 (1342)	5.5 (140)	8.8 (224)
SE2.45.A100.135.6.52E	33.4 (849)	26.8 (680)	12 X M25	47.3 (1202)	18.5 (471)	7.9 (200)	22.2 (565)	64.7 (1644)	49 (1245)	35.3 (896)	6.7 (170)	3.5 (89)	52.8 (1342)	5.5 (140)	8.8 (224)
SE2.45.A100.160.6.52E	33.4 (849)	26.8 (680)	12 X M25	47.3 (1202)	18.5 (471)	7.9 (200)	22.2 (565)	64.7 (1644)	49 (1245)	35.3 (896)	6.7 (170)	3.5 (89)	52.8 (1342)	5.5 (140)	8.8 (224)
SE2.50.A120.190.6.52E	37.8 (961)	27.2 (691)	12 X M25	49.4 (1254)	21.7 (551)	7.9 (200)	26.4 (670)	73.1 (1856)	53.4 (1357)	39.2 (996)	6.7 (170)	3.5 (89)	54.9 (1394)	5.5 (140)	10.1 (256)
SE2.50.A120.215.6.52E	37.8 (961)	27.2 (691)	12 X M25	49.4 (1254)	21.7 (551)	7.9 (200)	26.4 (670)	73.1 (1856)	53.4 (1357)	39.2 (996)	6.7 (170)	3.5 (89)	54.9 (1394)	5.5 (140)	10.1 (256)
SE2.50.A120.255.6.52E	37.8 (961)	27.2 (691)	12 X M25	49.4 (1254)	21.7 (551)	7.9 (200)	26.4 (670)	73.1 (1856)	53.4 (1357)	39.2 (996)	6.7 (170)	3.5 (89)	54.9 (1394)	5.5 (140)	10.1 (256)
SEV.30.A30.175.2.52H	20.7 (525)	15.2 (385)	8 X M20	44.3 (1124)	9.1 (230)	4.3 (110)	8.7 (220)	38.9 (988)	30 (762)	22.3 (567)	4.3 (110)	2.4 (60)	47.8 (1214)	3.5 (90)	9.4 (240)
SEV.30.A30.200.2.52H	20.7 (525)	15.2 (385)	8 X M20	44.3 (1124)	9.1 (230)	4.3 (110)	8.7 (220)	38.9 (988)	30 (762)	22.3 (567)	4.3 (110)	2.4 (60)	47.8 (1214)	3.5 (90)	9.4 (240)
SEV.30.A30.230.2.52H	20.7 (525)	15.2 (385)	8 X M20	44.3 (1124)	9.1 (230)	4.3 (110)	8.7 (220)	38.9 (988)	30 (762)	22.3 (567)	4.3 (110)	2.4 (60)	47.8 (1214)	3.5 (90)	9.4 (240)
SEV.30.A30.250.2.52H	20.7 (525)	15.2 (385)	8 X M20	44.3 (1124)	9.1 (230)	4.3 (110)	8.7 (220)	38.9 (988)	30 (762)	22.3 (567)	4.3 (110)	2.4 (60)	47.8 (1214)	3.5 (90)	9.4 (240)
SEV.30.A30.300.2.52H	20.7 (525)	15.2 (385)	8 X M20	44.3 (1124)	9.1 (230)	4.3 (110)	8.7 (220)	38.9 (988)	30 (762)	22.3 (567)	4.3 (110)	2.4 (60)	47.8 (1214)	3.5 (90)	9.4 (240)
SEV.30.A30.335.2.52H	20.7 (525)	15.2 (385)	8 X M20	44.3 (1124)	9.1 (230)	4.3 (110)	8.7 (220)	38.9 (988)	30 (762)	22.3 (567)	4.3 (110)	2.4 (60)	47.8 (1214)	3.5 (90)	9.4 (240)
SEV.30.A30.390.2.52H	20.7 (525)	15.2 (385)	8 X M20	44.3 (1124)	9.1 (230)	4.3 (110)	8.7 (220)	38.9 (988)	30 (762)	22.3 (567)	4.3 (110)	2.4 (60)	47.8 (1214)	3.5 (90)	9.4 (240)
SEV.30.A30.420.2.52H	20.7 (525)	15.2 (385)	8 X M20	44.3 (1124)	9.1 (230)	4.3 (110)	8.7 (220)	38.9 (988)	30 (762)	22.3 (567)	4.3 (110)	2.4 (60)	47.8 (1214)	3.5 (90)	9.4 (240)

SE/SE1/SE2/SEV [in (mm)] (part 2)

Pump type SE1/SE2/SEV	Z13	Z14	Z15	Z16	Z17G	Z17S	Z23	Z23 Ex.	S3OPR	S3OPR Ex.	ZDC1	ZDN1	ZDT1	ZL1	ZL2	ZM [Qty x mm]
SE1.30.A40.175.2.52S	0	0	8.7 (220)	16.3 (413)	0.1 (2.9)	0.1 (2.8)	12 (305)	12 (305)	16.3 (415)	16.3 (415)	7.5 (190)	4"	0.8 (21)	17.4 (443)	4.2 (107)	4 x M16
SE.A40.175.2.52S	0	0	8.7 (220)	16.3 (413)	0.1 (2.9)	0.1 (2.8)	12.2 (309)	12.2 (309)	15.8 (401)	15.8 (401)	7.5 (190)	4"	0.8 (21)	17.4 (443)	4.2 (107)	4 x M16
SE1.30.A40.200.2.52S	0	0	8.7 (220)	16.3 (413)	0.1 (2.9)	0.1 (2.8)	12 (305)	12 (305)	16.3 (415)	16.3 (415)	7.5 (190)	4"	0.8 (21)	17.4 (443)	4.2 (107)	4 x M16
SE.A40.200.2.52S	0	0	8.7 (220)	16.3 (413)	0.1 (2.9)	0.1 (2.8)	12.2 (309)	12.2 (309)	15.8 (401)	15.8 (401)	7.5 (190)	4"	0.8 (21)	17.4 (443)	4.2 (107)	4 x M16
SE1.30.A40.230.2.52S	0	0	8.7 (220)	16.3 (413)	0.1 (2.9)	0.1 (2.8)	12 (305)	12 (305)	16.3 (415)	16.3 (415)	7.5 (190)	4"	0.8 (21)	17.4 (443)	4.2 (107)	4 x M16
SE.A40.230.2.52S	0	0	8.7 (220)	16.3 (413)	0.1 (2.9)	0.1 (2.8)	12.2 (309)	12.2 (309)	15.8 (401)	15.8 (401)	7.5 (190)	4"	0.8 (21)	17.4 (443)	4.2 (107)	4 x M16
SE1.30.A40.250.2.52S	0	0	8.7 (220)	16.3 (413)	0.1 (2.9)	0.1 (2.8)	12 (305)	12 (305)	16.3 (415)	16.3 (415)	7.5 (190)	4"	0.8 (21)	17.4 (443)	4.2 (107)	4 x M16
SE.A40.250.2.52S	0	0	8.7 (220)	16.3 (413)	0.1 (2.9)	0.1 (2.8)	12.2 (309)	12.2 (309)	15.8 (401)	15.8 (401)	7.5 (190)	4"	0.8 (21)	17.4 (443)	4.2 (107)	4 x M16
SE1.30.A40.120.4.52H	3.1 (80)	0	8.7 (220)	16.3 (413)	0.1 (2.9)	0.1 (2.8)	12.9 (328)	12.9 (328)	15.3 (388)	15.3 (388)	7.5 (190)	4"	0.8 (21)	17.4 (443)	4.2 (107)	4 x M16
SE.A40.120.4.52H	3.1 (80)	0	8.7 (220)	16.3 (413)	0.1 (2.9)	0.1 (2.8)	12.9 (327)	12.9 (327)	15.2 (387)	15.2 (387)	7.5 (190)	4"	0.8 (21)	17.4 (443)	4.2 (107)	4 x M16
SE1.30.A40.150.4.52H	3.1 (80)	0	8.7 (220)	16.3 (413)	0.1 (2.9)	0.1 (2.8)	12.9 (328)	12.9 (328)	15.3 (388)	15.3 (388)	7.5 (190)	4"	0.8 (21)	17.4 (443)	4.2 (107)	4 x M16

Pump type SE1/SE2/SEV	Z13	Z14	Z15	Z16	Z17G	Z17S	Z23	Z23 Ex.	S3OPR	S3OPR Ex.	ZDC1	ZDN1	ZDT1	ZL1	ZL2	ZM [Qty x mm]
SE.A40.150.4.52H	3.1 (80)	0	8.7 (220)	16.3 (413)	0.1 (2.9)	0.1 (2.8)	12.9 (327)	12.9 (327)	15.2 (387)	15.2 (387)	7.5 (190)	4"	0.8 (21)	17.4 (443)	4.2 (107)	4 x M16
SE1.30.A40.175.4.52H	3.1 (80)	0	8.7 (220)	16.3 (413)	0.1 (2.9)	0.1 (2.8)	12.9 (328)	12.9 (328)	15.3 (388)	15.3 (388)	7.5 (190)	4"	0.8 (21)	17.4 (443)	4.2 (107)	4 x M16
SE.A40.175.4.52H	3.1 (80)	0	8.7 (220)	16.3 (413)	0.1 (2.9)	0.1 (2.8)	12.9 (327)	12.9 (327)	15.2 (387)	15.2 (387)	7.5 (190)	4"	0.8 (21)	17.4 (443)	4.2 (107)	4 x M16
SE1.30.A40.200.4.52H	3.1 (80)	0	8.7 (220)	16.3 (413)	0.1 (2.9)	0.1 (2.8)	12.9 (328)	12.9 (328)	15.3 (388)	15.3 (388)	7.5 (190)	4"	0.8 (21)	17.4 (443)	4.2 (107)	4 x M16
SE.A40.200.4.52H	3.1 (80)	0	8.7 (220)	16.3 (413)	0.1 (2.9)	0.1 (2.8)	12.9 (327)	12.9 (327)	15.2 (387)	15.2 (387)	7.5 (190)	4"	0.8 (21)	17.4 (443)	4.2 (107)	4 x M16
SE1.35.A40.245.4.52H	3.3 (84)	0	8.7 (220)	16.3 (413)	0.1 (2.9)	0.1 (2.8)	13 (329)	13 (329)	15.2 (385)	15.2 (385)	7.5 (190)	4"	0.8 (21)	17.4 (443)	4.2 (107)	4 x M16
SE.A40.245.4.52H	3.3 (84)	0	8.7 (220)	16.3 (413)	0.1 (2.9)	0.1 (2.8)	13 (330)	13 (330)	15.2 (386)	15.2 (386)	7.5 (190)	4"	0.8 (21)	17.4 (443)	4.2 (107)	4 x M16
SE1.35.A40.270.4.52H	3.3 (84)	0	8.7 (220)	16.3 (413)	0.1 (2.9)	0.1 (2.8)	13 (329)	13 (329)	15.2 (385)	15.2 (385)	7.5 (190)	4"	0.8 (21)	17.4 (443)	4.2 (107)	4 x M16
SE.A40.270.4.52H	3.3 (84)	0	8.7 (220)	16.3 (413)	0.1 (2.9)	0.1 (2.8)	13 (330)	13 (330)	15.2 (386)	15.2 (386)	7.5 (190)	4"	0.8 (21)	17.4 (443)	4.2 (107)	4 x M16
SE1.35.A40.300.4.52H	3.3 (84)	0	8.7 (220)	16.3 (413)	0.1 (2.9)	0.1 (2.8)	13 (329)	13 (329)	15.2 (385)	15.2 (385)	7.5 (190)	4"	0.8 (21)	17.4 (443)	4.2 (107)	4 x M16
SE.A40.300.4.52H	3.3 (84)	0	8.7 (220)	16.3 (413)	0.1 (2.9)	0.1 (2.8)	13 (330)	13 (330)	15.2 (386)	15.2 (386)	7.5 (190)	4"	0.8 (21)	17.4 (443)	4.2 (107)	4 x M16
SE1.35.A40.330.4.52H	3.3 (84)	0	8.7 (220)	16.3 (413)	0.1 (2.9)	0.1 (2.8)	13 (329)	13 (329)	15.2 (385)	15.2 (385)	7.5 (190)	4"	0.8 (21)	17.4 (443)	4.2 (107)	4 x M16
SE.A40.330.4.52H	3.3 (84)	0	8.7 (220)	16.3 (413)	0.1 (2.9)	0.1 (2.8)	13 (330)	13 (330)	15.2 (386)	15.2 (386)	7.5 (190)	4"	0.8 (21)	17.4 (443)	4.2 (107)	4 x M16
SE1.30.A60.120.4.52H	0	0	11 (280)	17.7 (450)	0.1 (3.2)	0.1 (3.1)	12.9 (328)	12.9 (328)	17 (433)	17 (433)	9.4 (240)	6"	0.9 (22)	21.7 (552)	5.1 (129)	4xM16
SE.A60.120.4.52H	0	0	11 (280)	17.7 (450)	0.1 (3.2)	0.1 (3.1)	12.9 (327)	12.9 (327)	17 (432)	17 (432)	9.4 (240)	6"	0.9 (22)	21.7 (552)	5.1 (129)	4xM16
SE1.30.A60.150.4.52H	0	0	11 (280)	17.7 (450)	0.1 (3.2)	0.1 (3.1)	12.9 (328)	12.9 (328)	17 (433)	17 (433)	9.4 (240)	6"	0.9 (22)	21.7 (552)	5.1 (129)	4xM16
SE.A60.150.4.52H	0	0	11 (280)	17.7 (450)	0.1 (3.2)	0.1 (3.1)	12.9 (327)	12.9 (327)	17 (432)	17 (432)	9.4 (240)	6"	0.9 (22)	21.7 (552)	5.1 (129)	4xM16
SE1.30.A60.175.4.52H	0	0	11 (280)	17.7 (450)	0.1 (3.2)	0.1 (3.1)	12.9 (328)	12.9 (328)	17 (433)	17 (433)	9.4 (240)	6"	0.9 (22)	21.7 (552)	5.1 (129)	4xM16
SE.A60.175.4.52H	0	0	11 (280)	17.7 (450)	0.1 (3.2)	0.1 (3.1)	12.9 (327)	12.9 (327)	17 (432)	17 (432)	9.4 (240)	6"	0.9 (22)	21.7 (552)	5.1 (129)	4xM16
SE1.30.A60.200.4.52H	0	0	11 (280)	17.7 (450)	0.1 (3.2)	0.1 (3.1)	12.9 (328)	12.9 (328)	17 (433)	17 (433)	9.4 (240)	6"	0.9 (22)	21.7 (552)	5.1 (129)	4xM16
SE.A60.200.4.52H	0	0	11 (280)	17.7 (450)	0.1 (3.2)	0.1 (3.1)	12.9 (327)	12.9 (327)	17 (432)	17 (432)	9.4 (240)	6"	0.9 (22)	21.7 (552)	5.1 (129)	4xM16
SE1.35.A60.245.4.52H	0	0	11 (280)	17.7 (450)	0.1 (3.2)	0.1 (3.1)	12.9 (328)	12.9 (328)	16.9 (430)	17 (432)	9.4 (240)	6"	0.9 (22)	21.7 (552)	5.1 (129)	4xM16
SE.A60.245.4.52H	0	0	11 (280)	17.7 (450)	0.1 (3.2)	0.1 (3.1)	13 (330)	13 (330)	17 (432)	17 (432)	9.4 (240)	6"	0.9 (22)	21.7 (552)	5.1 (129)	4xM16
SE1.35.A60.270.4.52H	0	0	11 (280)	17.7 (450)	0.1 (3.2)	0.1 (3.1)	12.9 (328)	12.9 (328)	16.9 (430)	16.9 (430)	9.4 (240)	6"	0.9 (22)	21.7 (552)	5.1 (129)	4xM16
SE.A60.270.4.52H	0	0	11 (280)	17.7 (450)	0.1 (3.2)	0.1 (3.1)	13 (330)	13 (330)	17 (432)	17 (432)	9.4 (240)	6"	0.9 (22)	21.7 (552)	5.1 (129)	4xM16
SE1.35.A60.300.4.52H	0	0	11 (280)	17.7 (450)	0.1 (3.2)	0.1 (3.1)	12.9 (328)	12.9 (328)	16.9 (430)	16.9 (430)	9.4 (240)	6"	0.9 (22)	21.7 (552)	5.1 (129)	4xM16
SE.A60.300.4.52H	0	0	11 (280)	17.7 (450)	0.1 (3.2)	0.1 (3.1)	13 (330)	13 (330)	17 (432)	17 (432)	9.4 (240)	6"	0.9 (22)	21.7 (552)	5.1 (129)	4xM16

Pump type SE1/SE2/SEV	Z13	Z14	Z15	Z16	Z17G	Z17S	Z23	Z23 Ex.	S3OPR	S3OPR Ex.	ZDC1	ZDN1	ZDT1	ZL1	ZL2	ZM [Qty x mm]
SE1.35.A60.330.4.52H	0	0	11 (280)	17.7 (450)	0.1 (3.2)	0.1 (3.1)	12.9 (328)	12.9 (328)	16.9 (430)	16.9 (430)	9.4 (240)	6"	0.9 (22)	21.7 (552)	5.1 (129)	4xM16
SE1.40.A80.120.4.52M	4.3 (108)	3.4 (86)	14.4 (365)	19.1 (485)	0.1 (3.2)	0.1 (3.1)	13.7 (347)	13.7 (347)	15 (379)	15 (379)	11.7 (298)	8"	1.2 (31)	30 (761)	8.8 (223)	4 x M24
SE1.40.A80.150.4.52M	4.3 (108)	3.4 (86)	14.4 (365)	19.1 (485)	0.1 (3.2)	0.1 (3.1)	13.7 (347)	13.7 (347)	15 (379)	15 (379)	11.7 (298)	8"	1.2 (31)	30 (761)	8.8 (223)	4 x M24
SE1.40.A80.175.4.52M	4.3 (108)	3.4 (86)	14.4 (365)	19.1 (485)	0.1 (3.2)	0.1 (3.1)	13.7 (347)	13.7 (347)	15 (379)	15 (379)	11.7 (298)	8"	1.2 (31)	30 (761)	8.8 (223)	4 x M24
SE1.40.A80.200.4.52M	4.3 (108)	3.4 (86)	14.4 (365)	19.1 (485)	0.1 (3.2)	0.1 (3.1)	13.7 (347)	13.7 (347)	15 (379)	15 (379)	11.7 (298)	8"	1.2 (31)	30 (761)	8.8 (223)	4 x M24
SE1.45.A80.245.4.52M	5.2 (131)	3.4 (86)	14.4 (365)	19.1 (485)	0.1 (3.2)	0.1 (3.1)	14.1 (357)	14.1 (357)	14.4 (366)	14.4 (366)	11.7 (298)	8"	1.2 (31)	30 (761)	8.8 (223)	4 x M24
SE1.45.A80.270.4.52M	5.2 (131)	3.4 (86)	14.4 (365)	19.1 (485)	0.1 (3.2)	0.1 (3.1)	14.1 (357)	14.1 (357)	14.4 (366)	14.4 (366)	11.7 (298)	8"	1.2 (31)	30 (761)	8.8 (223)	4 x M24
SE1.45.A80.300.4.52M	5.2 (131)	3.4 (86)	14.4 (365)	19.1 (485)	0.1 (3.2)	0.1 (3.1)	14.1 (357)	14.1 (357)	14.4 (366)	14.4 (366)	11.7 (298)	8"	1.2 (31)	30 (761)	8.8 (223)	4 x M24
SE1.45.A80.330.4.52M	5.2 (131)	3.4 (86)	14.4 (365)	19.1 (485)	0.1 (3.2)	0.1 (3.1)	14.1 (357)	14.1 (357)	14.4 (366)	14.4 (366)	11.7 (298)	8"	1.2 (31)	30 (761)	8.8 (223)	4 x M24
SE2.45.A100.150.4.52L	4.5 (114)	3.4 (86)	14.8 (375)	21.5 (545)	0.1 (3.2)	0.1 (3.1)	14.6 (371)	14.6 (371)	15.6 (397)	15.6 (397)	14.3 (362)	10"	1.3 (32)	31.3 (795)	8.9 (226)	4 x M24
SE2.45.A100.175.4.52L	4.5 (114)	3.4 (86)	14.8 (375)	21.5 (545)	0.1 (3.2)	0.1 (3.1)	14.6 (371)	14.6 (371)	15.6 (397)	15.6 (397)	14.3 (362)	10"	1.3 (32)	31.3 (795)	8.9 (226)	4 x M24
SE2.45.A100.200.4.52L	4.5 (114)	3.4 (86)	14.8 (375)	21.5 (545)	0.1 (3.2)	0.1 (3.1)	14.6 (371)	14.6 (371)	15.6 (397)	15.6 (397)	14.3 (362)	10"	1.3 (32)	31.3 (795)	8.9 (226)	4 x M24
SE2.45.A100.245.4.52L	4.5 (114)	3.4 (86)	14.8 (375)	21.5 (545)	0.1 (3.2)	0.1 (3.1)	14.6 (371)	14.6 (371)	15.6 (397)	15.6 (397)	14.3 (362)	10"	1.3 (32)	31.3 (795)	8.9 (226)	4 x M24
SE2.45.A100.270.4.52L	4.5 (114)	3.4 (86)	14.8 (375)	21.5 (545)	0.1 (3.2)	0.1 (3.1)	14.6 (371)	14.6 (371)	15.6 (397)	15.6 (397)	14.3 (362)	10"	1.3 (32)	31.3 (795)	8.9 (226)	4 x M24
SE2.45.A100.300.4.52L	4.5 (114)	3.4 (86)	14.8 (375)	21.5 (545)	0.1 (3.2)	0.1 (3.1)	14.6 (371)	14.6 (371)	15.6 (397)	15.6 (397)	14.3 (362)	10"	1.3 (32)	31.3 (795)	8.9 (226)	4 x M24
SE2.45.A100.330.4.52L	4.5 (114)	3.4 (86)	14.8 (375)	21.5 (545)	0.1 (3.2)	0.1 (3.1)	14.6 (371)	14.6 (371)	15.6 (397)	15.6 (397)	14.3 (362)	10"	1.3 (32)	31.3 (795)	8.9 (226)	4 x M24
SE2.45.A100.110.6.52E	4.5 (114)	3.4 (86)	14.8 (375)	21.5 (545)	0.1 (3.2)	0.1 (3.1)	14.6 (371)	14.6 (371)	15.6 (397)	15.6 (397)	14.3 (362)	10"	1.3 (32)	31.3 (795)	8.9 (226)	4 x M24
SE2.45.A100.135.6.52E	4.5 (114)	3.4 (86)	14.8 (375)	21.5 (545)	0.1 (3.2)	0.1 (3.1)	14.6 (371)	14.6 (371)	15.6 (397)	15.6 (397)	14.3 (362)	10"	1.3 (32)	31.3 (795)	8.9 (226)	4 x M24
SE2.45.A100.160.6.52E	4.5 (114)	3.4 (86)	14.8 (375)	21.5 (545)	0.1 (3.2)	0.1 (3.1)	14.6 (371)	14.6 (371)	15.6 (397)	15.6 (397)	14.3 (362)	10"	1.3 (32)	31.3 (795)	8.9 (226)	4 x M24
SE2.50.A120.190.6.52E	4.5 (114)	3.7 (95)	17.7 (450)	25.6 (650)	0.1 (3.2)	0.1 (3.1)	16.7 (423)	16.7 (423)	17.7 (449)	17.7 (449)	17 (432)	12"	1.3 (32)	35.2 (895)	8.9 (226)	4 x M24
SE2.50.A120.215.6.52E	4.5 (114)	3.7 (95)	17.7 (450)	25.6 (650)	0.1 (3.2)	0.1 (3.1)	16.7 (423)	16.7 (423)	17.7 (449)	17.7 (449)	17 (432)	12"	1.3 (32)	35.2 (895)	8.9 (226)	4 x M24
SE2.50.A120.255.6.52E	4.5 (114)	3.7 (95)	17.7 (450)	25.6 (650)	0.1 (3.2)	0.1 (3.1)	16.7 (423)	16.7 (423)	17.7 (449)	17.7 (449)	17 (432)	12"	1.3 (32)	35.2 (895)	8.9 (226)	4 x M24
SEV.30.A30.175.2.52H	0	0	8.7 (220)	16.3 (413)	0.1 (2.9)	0.1 (2.8)	11.5 (293)	11.5 (293)	15.1 (383)	15.1 (383)	7.5 (190)	4"	0.8 (21)	18.2 (463)	5 (127)	4 x M16
SEV.30.A30.200.2.52H	0	0	8.7 (220)	16.3 (413)	0.1 (2.9)	0.1 (2.8)	11.5 (293)	11.5 (293)	15.1 (383)	15.1 (383)	7.5 (190)	4"	0.8 (21)	18.2 (463)	5 (127)	4 x M16
SEV.30.A30.230.2.52H	0	0	8.7 (220)	16.3 (413)	0.1 (2.9)	0.1 (2.8)	11.5 (293)	11.5 (293)	15.1 (383)	15.1 (383)	7.5 (190)	4"	0.8 (21)	18.2 (463)	5 (127)	4 x M16
SEV.30.A30.250.2.52H	0	0	8.7 (220)	16.3 (413)	0.1 (2.9)	0.1 (2.8)	11.5 (293)	11.5 (293)	15.1 (383)	15.1 (383)	7.5 (190)	4"	0.8 (21)	18.2 (463)	5 (127)	4 x M16
SEV.30.A30.300.2.52H	0	0	8.7 (220)	16.3 (413)	0.1 (2.9)	0.1 (2.8)	11.5 (293)	11.5 (293)	15.1 (383)	15.1 (383)	7.5 (190)	4"	0.8 (21)	18.2 (463)	5 (127)	4 x M16

Pump type SE1/SE2/SEV	Z13	Z14	Z15	Z16	Z17G	Z17S	Z23	Z23 Ex.	S3OPR	S3OPR Ex.	ZDC1	ZDN1	ZDT1	ZL1	ZL2	ZM [Qty x mm]
SEV.30.A30.335.2.52H	0	0	8.7 (220)	16.3 (413)	0.1 (2.9)	0.1 (2.8)	11.5 (293)	11.5 (293)	15.1 (383)	15.1 (383)	7.5 (190)	4"	0.8 (21)	18.2 (463)	5 (127)	4 x M16
SEV.30.A30.390.2.52H	0	0	8.7 (220)	16.3 (413)	0.1 (2.9)	0.1 (2.8)	11.5 (293)	11.5 (293)	15.1 (383)	15.1 (383)	7.5 (190)	4"	0.8 (21)	18.2 (463)	5 (127)	4 x M16
SEV.30.A30.420.2.52H	0	0	8.7 (220)	16.3 (413)	0.1 (2.9)	0.1 (2.8)	11.5 (293)	11.5 (293)	15.1 (383)	15.1 (383)	7.5 (190)	4"	0.8 (21)	18.2 (463)	5 (127)	4 x M16

SL/SL1/SL2/SLV [in (mm)] (part 1)

Pump type SL1/SL2/SLV	C	F	Z01 [Qty x mm]	Z1	Z2	Z3	Z4	Z6	Z7	Z8	Z9	Z10	Z11	Z12a	Z12b
SL1.30.A40.175.2.52S	18.8 (478)	15.2 (386)	8 x M20	5.4 (1136)	9.1 (230)	4.3 (110)	8.7 (220)	36.3 (921)	27.4 (695)	19.8 (502)	4.3 (110)	2.4 (60)	49.1 (1246)	4.3 (110)	9.4 (240)
SL.A40.175.2.52S	18.7 (476)	15 (382)	8 x M20	44.9 (1140)	9.1 (230)	4.3 (110)	8.7 (220)	36.2 (919)	27.3 (693)	19.8 (502)	4.3 (110)	2.4 (60)	48.5 (1232)	3.6 (92)	9.4 (240)
SL1.30.A40.200.2.52S	18.8 (478)	15.2 (386)	8 x M20	5.4 (1136)	9.1 (230)	4.3 (110)	8.7 (220)	36.3 (921)	27.4 (695)	19.8 (502)	4.3 (110)	2.4 (60)	49.1 (1246)	4.3 (110)	9.4 (240)
SL.A40.200.2.52S	18.7 (476)	15 (382)	8 x M20	44.9 (1140)	9.1 (230)	4.3 (110)	8.7 (220)	36.2 (919)	27.3 (693)	19.8 (502)	4.3 (110)	2.4 (60)	48.5 (1232)	3.6 (92)	9.4 (240)
SL1.30.A40.230.2.52S	18.8 (478)	15.2 (386)	8 x M20	5.4 (1136)	9.1 (230)	4.3 (110)	8.7 (220)	36.3 (921)	27.4 (695)	19.8 (502)	4.3 (110)	2.4 (60)	49.1 (1246)	4.3 (110)	9.4 (240)
SL.A40.230.2.52S	18.7 (476)	15 (382)	8 x M20	44.9 (1140)	9.1 (230)	4.3 (110)	8.7 (220)	36.2 (919)	27.3 (693)	19.8 (502)	4.3 (110)	2.4 (60)	48.5 (1232)	3.6 (92)	9.4 (240)
SL1.30.A40.250.2.52S	18.8 (478)	15.2 (386)	8 x M20	5.4 (1136)	9.1 (230)	4.3 (110)	8.7 (220)	36.3 (921)	27.4 (695)	19.8 (502)	4.3 (110)	2.4 (60)	49.1 (1246)	4.3 (110)	9.4 (240)
SL.A40.250.2.52S	18.7 (476)	15 (382)	8 x M20	44.9 (1140)	9.1 (230)	4.3 (110)	8.7 (220)	36.2 (919)	27.3 (693)	19.8 (502)	4.3 (110)	2.4 (60)	48.5 (1232)	3.6 (92)	9.4 (240)
SL1.30.A40.120.4.52H	23.2 (590)	16.8 (427)	8 x M20	45.6 (1159)	9.1 (230)	4.3 (110)	8.7 (220)	40.7 (1033)	31.8 (807)	23.5 (597)	4.3 (110)	2.4 (60)	51.1 (1299)	5.5 (140)	9.4 (240)
SL.A40.120.4.52H	23.2 (590)	16.8 (427)	8 x M20	45.6 (1158)	9.1 (230)	4.3 (110)	8.7 (220)	40.7 (1033)	31.8 (807)	23.5 (597)	4.3 (110)	2.4 (60)	11.7 (1298)	5.5 (140)	9.4 (240)
SL1.30.A40.150.4.52H	23.2 (590)	16.8 (427)	8 x M20	45.6 (1159)	9.1 (230)	4.3 (110)	8.7 (220)	40.7 (1033)	31.8 (807)	23.5 (597)	4.3 (110)	2.4 (60)	51.1 (1299)	5.5 (140)	9.4 (240)
SL.A40.150.4.52H	23.2 (590)	16.8 (427)	8 x M20	45.6 (1158)	9.1 (230)	4.3 (110)	8.7 (220)	40.7 (1033)	31.8 (807)	23.5 (597)	4.3 (110)	2.4 (60)	11.7 (1298)	5.5 (140)	9.4 (240)
SL1.30.A40.175.4.52H	23.2 (590)	16.8 (427)	8 x M20	45.6 (1159)	9.1 (230)	4.3 (110)	8.7 (220)	40.7 (1033)	31.8 (807)	23.5 (597)	4.3 (110)	2.4 (60)	51.1 (1299)	5.5 (140)	9.4 (240)
SL.A40.175.4.52H	23.2 (590)	16.8 (427)	8 x M20	45.6 (1158)	9.1 (230)	4.3 (110)	8.7 (220)	40.7 (1033)	31.8 (807)	23.5 (597)	4.3 (110)	2.4 (60)	11.7 (1298)	5.5 (140)	9.4 (240)
SL1.30.A40.200.4.52H	23.2 (590)	16.8 (427)	8 x M20	45.6 (1159)	9.1 (230)	4.3 (110)	8.7 (220)	40.7 (1033)	31.8 (807)	23.5 (597)	4.3 (110)	2.4 (60)	51.1 (1299)	5.5 (140)	9.4 (240)
SL.A40.200.4.52H	23.2 (590)	16.8 (427)	8 x M20	45.6 (1158)	9.1 (230)	4.3 (110)	8.7 (220)	40.7 (1033)	31.8 (807)	23.5 (597)	4.3 (110)	2.4 (60)	11.7 (1298)	5.5 (140)	9.4 (240)
SL1.35.A40.245.4.52H	24 (609)	18.1 (460)	8 x M20	44.3 (1126)	9.1 (230)	4.3 (110)	8.7 (220)	41.4 (1052)	32.5 (826)	23.5 (597)	4.3 (110)	2.4 (60)	49.8 (1266)	5.5 (140)	9.4 (240)
SL.A40.245.4.52H	24 (609)	18.2 (462)	8 x M20	45.7 (1161)	9.1 (230)	4.3 (110)	8.7 (220)	41.4 (1052)	32.5 (826)	23.5 (597)	4.3 (110)	2.4 (60)	51.2 (1301)	5.5 (140)	9.4 (240)
SL1.35.A40.270.4.52H	24 (609)	18.1 (460)	8 x M20	45.7 (1160)	9.1 (230)	4.3 (110)	8.7 (220)	41.4 (1052)	32.5 (826)	23.5 (597)	4.3 (110)	2.4 (60)	51.2 (1300)	5.5 (140)	9.4 (240)
SL.A40.270.4.52H	24 (609)	18.2 (462)	8 x M20	45.7 (1161)	9.1 (230)	4.3 (110)	8.7 (220)	41.4 (1052)	32.5 (826)	23.5 (597)	4.3 (110)	2.4 (60)	51.2 (1301)	5.5 (140)	9.4 (240)
SL1.35.A40.300.4.52H	24 (609)	18.1 (460)	8 x M20	45.7 (1160)	9.1 (230)	4.3 (110)	8.7 (220)	41.4 (1052)	32.5 (826)	23.5 (597)	4.3 (110)	2.4 (60)	51.2 (1300)	5.5 (140)	9.4 (240)
SL.A40.300.4.52H	24 (609)	18.2 (462)	8 x M20	45.7 (1161)	9.1 (230)	4.3 (110)	8.7 (220)	41.4 (1052)	32.5 (826)	23.5 (597)	4.3 (110)	2.4 (60)	51.2 (1301)	5.5 (140)	9.4 (240)

Pump type SL1/SL2/SLV	C	F	Z01 [Qty x mm]	Z1	Z2	Z3	Z4	Z6	Z7	Z8	Z9	Z10	Z11	Z12a	Z12b
SL1.35.A40.330.4.52H	24 (609)	18.1 (460)	8 x M20	45.7 (1160)	9.1 (230)	4.3 (110)	8.7 (220)	41.4 (1052)	32.5 (826)	23.5 (597)	4.3 (110)	2.4 (60)	51.2 (1300)	5.5 (140)	9.4 (240)
SL.A40.330.4.52H	24 (609)	18.2 (462)	8 x M20	45.7 (1161)	9.1 (230)	4.3 (110)	8.7 (220)	41.4 (1052)	32.5 (826)	23.5 (597)	4.3 (110)	2.4 (60)	51.2 (1301)	5.5 (140)	9.4 (240)
SL1.30.A60.120.4.52H	21.9 (557)	16.7 (424)	8 x M25	45.6 (1159)	11.8 (300)	4.8 (123)	11 (280)	43.7 (1109)	31.3 (796)	23.2 (589)	4.3 (110)	3.5 (89)	49.8 (1264)	4.1 (105)	10.8 (275)
SL.A60.120.4.52H	22 (558)	16.7 (424)	8 x M25	45.6 (1158)	11.8 (300)	4.8 (123)	11 (280)	43.7 (1110)	31.4 (797)	23.2 (589)	4.3 (110)	3.5 (89)	49.7 (1263)	4.1 (105)	10.8 (275)
SL1.30.A60.150.4.52H	21.9 (557)	16.7 (424)	8 x M25	45.6 (1159)	11.8 (300)	4.8 (123)	11 (280)	43.7 (1109)	31.3 (796)	23.2 (589)	4.3 (110)	3.5 (89)	49.8 (1264)	4.1 (105)	10.8 (275)
SL.A60.150.4.52H	22 (558)	16.7 (424)	8 x M25	45.6 (1158)	11.8 (300)	4.8 (123)	11 (280)	43.7 (1110)	31.4 (797)	23.2 (589)	4.3 (110)	3.5 (89)	49.7 (1263)	4.1 (105)	10.8 (275)
SL1.30.A60.175.4.52H	21.9 (557)	16.7 (424)	8 x M25	45.6 (1159)	11.8 (300)	4.8 (123)	11 (280)	43.7 (1109)	31.3 (796)	23.2 (589)	4.3 (110)	3.5 (89)	49.8 (1264)	4.1 (105)	10.8 (275)
SL.A60.175.4.52H	22 (558)	16.7 (424)	8 x M25	45.6 (1158)	11.8 (300)	4.8 (123)	11 (280)	43.7 (1110)	31.4 (797)	23.2 (589)	4.3 (110)	3.5 (89)	49.7 (1263)	4.1 (105)	10.8 (275)
SL1.30.A60.200.4.52H	21.9 (557)	16.7 (424)	8 x M25	44.3 (1125)	11.8 (300)	4.8 (123)	11 (280)	43.7 (1109)	31.3 (796)	23.2 (589)	4.3 (110)	3.5 (89)	48.4 (1230)	4.1 (105)	10.8 (275)
SL.A60.200.4.52H	22 (558)	16.7 (424)	8 x M25	45.6 (1158)	11.8 (300)	4.8 (123)	11 (280)	43.7 (1110)	31.4 (797)	23.2 (589)	4.3 (110)	3.5 (89)	49.7 (1263)	4.1 (105)	10.8 (275)
SL1.35.A60.245.4.52H	23.8 (1157)	17.9 (454)	8 x M25	45.6 (1159)	11.8 (300)	4.8 (123)	11 (280)	45.6 (1157)	33.2 (844)	24.4 (619)	4.3 (110)	3.5 (89)	49.6 (1261)	4 (102)	10.8 (275)
SL.A60.245.4.52H	23.8 (1157)	17.9 (454)	8 x M25	45.7 (1161)	11.8 (300)	4.8 (123)	11 (280)	45.6 (1157)	33.2 (844)	24.4 (619)	4.3 (110)	3.5 (89)	49.7 (1263)	4 (102)	10.8 (275)
SL1.35.A60.270.4.52H	23.8 (1157)	17.9 (454)	8 x M25	45.6 (1159)	11.8 (300)	4.8 (123)	11 (280)	45.6 (1157)	33.2 (844)	24.4 (619)	4.3 (110)	3.5 (89)	49.6 (1261)	4 (102)	10.8 (275)
SL.A60.270.4.52H	23.8 (1157)	17.9 (454)	8 x M25	45.7 (1161)	11.8 (300)	4.8 (123)	11 (280)	45.6 (1157)	33.2 (844)	24.4 (619)	4.3 (110)	3.5 (89)	49.7 (1263)	4 (102)	10.8 (275)
SL1.35.A60.300.4.52H	23.8 (1157)	17.9 (454)	8 x M25	45.6 (1159)	11.8 (300)	4.8 (123)	11 (280)	45.6 (1157)	33.2 (844)	24.4 (619)	4.3 (110)	3.5 (89)	49.6 (1261)	4 (102)	10.8 (275)
SL.A60.300.4.52H	23.8 (1157)	17.9 (454)	8 x M25	45.7 (1161)	11.8 (300)	4.8 (123)	11 (280)	45.6 (1157)	33.2 (844)	24.4 (619)	4.3 (110)	3.5 (89)	49.7 (1263)	4 (102)	10.8 (275)
SL1.35.A60.330.4.52H	23.8 (1157)	17.9 (454)	8 x M25	45.6 (1159)	11.8 (300)	4.8 (123)	11 (280)	45.6 (1157)	33.2 (844)	24.4 (619)	4.3 (110)	3.5 (89)	49.6 (1261)	4 (102)	10.8 (275)
SL1.40.A80.120.4.52M	29 (737)	18.5 (470)	8 x M22	46.4 (1178)	16.9 (430)	7.9 (200)	21.1 (535)	59 (1498)	44.5 (1130)	35.2 (893)	6.7 (170)	3.5 (89)	51.9 (1318)	5.5 (140)	7.7 (196)
SL1.40.A80.150.4.52M	29 (737)	18.5 (470)	8 x M22	46.4 (1178)	16.9 (430)	7.9 (200)	21.1 (535)	59 (1498)	44.5 (1130)	35.2 (893)	6.7 (170)	3.5 (89)	51.9 (1318)	5.5 (140)	7.7 (196)
SL1.40.A80.175.4.52M	29 (737)	18.5 (470)	8 x M22	46.4 (1178)	16.9 (430)	7.9 (200)	21.1 (535)	59 (1498)	44.5 (1130)	35.2 (893)	6.7 (170)	3.5 (89)	51.9 (1318)	5.5 (140)	7.7 (196)
SL1.40.A80.200.4.52M	29 (737)	18.5 (470)	8 x M22	46.4 (1178)	16.9 (430)	7.9 (200)	21.1 (535)	59 (1498)	44.5 (1130)	35.2 (893)	6.7 (170)	3.5 (89)	51.9 (1318)	5.5 (140)	7.7 (196)
SL1.45.A80.245.4.52M	29.7 (755)	19.7 (500)	8 x M22	46.8 (1188)	16.9 (430)	7.9 (200)	21.1 (535)	59.7 (1516)	45.2 (1148)	35.2 (893)	6.7 (170)	3.5 (89)	52.3 (1328)	5.5 (140)	7.7 (196)
SL1.45.A80.270.4.52M	29.7 (755)	19.7 (500)	8 x M22	46.8 (1188)	16.9 (430)	7.9 (200)	21.1 (535)	59.7 (1516)	45.2 (1148)	35.2 (893)	6.7 (170)	3.5 (89)	52.3 (1328)	5.5 (140)	7.7 (196)
SL1.45.A80.300.4.52M	29.7 (755)	19.7 (500)	8 x M22	46.8 (1188)	16.9 (430)	7.9 (200)	21.1 (535)	59.7 (1516)	45.2 (1148)	35.2 (893)	6.7 (170)	3.5 (89)	52.3 (1328)	5.5 (140)	7.7 (196)
SL1.45.A80.330.4.52M	29.7 (755)	19.7 (500)	8 x M22	46.8 (1188)	16.9 (430)	7.9 (200)	21.1 (535)	59.7 (1516)	45.2 (1148)	35.2 (893)	6.7 (170)	3.5 (89)	52.3 (1328)	5.5 (140)	7.7 (196)
SL2.45.A100.150.4.52L	33.4 (849)	26.8 (680)	12 x M25	47.3 (1202)	18.5 (471)	7.9 (200)	22.2 (565)	64.7 (1644)	49 (1245)	35.3 (896)	6.7 (170)	3.5 (89)	1.7 (43)	5.5 (140)	8.8 (224)
SL2.45.A100.175.4.52L	33.4 (849)	26.8 (680)	12 x M25	47.3 (1202)	18.5 (471)	7.9 (200)	22.2 (565)	64.7 (1644)	49 (1245)	35.3 (896)	6.7 (170)	3.5 (89)	1.7 (43)	5.5 (140)	8.8 (224)

Pump type SL1/SL2/SLV	C	F	Z01 [Qty x mm]	Z1	Z2	Z3	Z4	Z6	Z7	Z8	Z9	Z10	Z11	Z12a	Z12b
SL2.45.A100.200.4.52L	33.4 (849)	26.8 (680)	12 x M25	47.3 (1202)	18.5 (471)	7.9 (200)	22.2 (565)	64.7 (1644)	49 (1245)	35.3 (896)	6.7 (170)	3.5 (89)	1.7 (1342)	5.5 (140)	8.8 (224)
SL2.45.A100.245.4.52L	33.4 (849)	26.8 (680)	12 x M25	47.3 (1202)	18.5 (471)	7.9 (200)	22.2 (565)	64.7 (1644)	49 (1245)	35.3 (896)	6.7 (170)	3.5 (89)	1.7 (1342)	5.5 (140)	8.8 (224)
SL2.45.A100.270.4.52L	33.4 (849)	26.8 (680)	12 x M25	47.3 (1202)	18.5 (471)	7.9 (200)	22.2 (565)	64.7 (1644)	49 (1245)	35.3 (896)	6.7 (170)	3.5 (89)	1.7 (1342)	5.5 (140)	8.8 (224)
SL2.45.A100.300.4.52L	33.4 (849)	26.8 (680)	12 x M25	47.3 (1202)	18.5 (471)	7.9 (200)	22.2 (565)	64.7 (1644)	49 (1245)	35.3 (896)	6.7 (170)	3.5 (89)	1.7 (1342)	5.5 (140)	8.8 (224)
SL2.45.A100.330.4.52L	33.4 (849)	26.8 (680)	12 x M25	47.3 (1202)	18.5 (471)	7.9 (200)	22.2 (565)	64.7 (1644)	49 (1245)	35.3 (896)	6.7 (170)	3.5 (89)	1.7 (1342)	5.5 (140)	8.8 (224)
SL2.45.A100.110.6.52E	33.4 (849)	26.8 (680)	12 x M25	47.3 (1202)	18.5 (471)	7.9 (200)	22.2 (565)	64.7 (1644)	49 (1245)	35.3 (896)	6.7 (170)	3.5 (89)	1.7 (1342)	5.5 (140)	8.8 (224)
SL2.45.A100.135.6.52E	33.4 (849)	26.8 (680)	12 x M25	47.3 (1202)	18.5 (471)	7.9 (200)	22.2 (565)	64.7 (1644)	49 (1245)	35.3 (896)	6.7 (170)	3.5 (89)	1.7 (1342)	5.5 (140)	8.8 (224)
SL2.45.A100.160.6.52E	33.4 (849)	26.8 (680)	12 x M25	47.3 (1202)	18.5 (471)	7.9 (200)	22.2 (565)	64.7 (1644)	49 (1245)	35.3 (896)	6.7 (170)	3.5 (89)	1.7 (1342)	5.5 (140)	8.8 (224)
SL2.50.A120.190.6.52E	37.8 (961)	27.2 (691)	12 x M25	49.4 (1254)	21.7 (551)	7.9 (200)	26.4 (670)	73.1 (1856)	53.4 (1357)	39.2 (996)	6.7 (170)	3.5 (89)	54.9 (1394)	5.5 (140)	10.1 (256)
SL2.50.A120.215.6.52E	37.8 (961)	27.2 (691)	12 x M25	49.4 (1254)	21.7 (551)	7.9 (200)	26.4 (670)	73.1 (1856)	53.4 (1357)	39.2 (996)	6.7 (170)	3.5 (89)	54.9 (1394)	5.5 (140)	10.1 (256)
SL2.50.A120.255.6.52E	37.8 (961)	27.2 (691)	12 x M25	49.4 (1254)	21.7 (551)	7.9 (200)	26.4 (670)	73.1 (1856)	53.4 (1357)	39.2 (996)	6.7 (170)	3.5 (89)	54.9 (1394)	5.5 (140)	10.1 (256)
SLV.30.A30.175.2.52H	20.7 (525)	15.2 (385)	8 x M20	44.3 (1124)	9.1 (230)	4.3 (110)	8.7 (220)	38.9 (988)	30 (762)	22.3 (567)	4.3 (110)	2.4 (60)	47.8 (1214)	3.5 (90)	9.4 (240)
SLV.30.A30.200.2.52H	20.7 (525)	15.2 (385)	8 x M20	44.3 (1124)	9.1 (230)	4.3 (110)	8.7 (220)	38.9 (988)	30 (762)	22.3 (567)	4.3 (110)	2.4 (60)	47.8 (1214)	3.5 (90)	9.4 (240)
SLV.30.A30.230.2.52H	20.7 (525)	15.2 (385)	8 x M20	44.3 (1124)	9.1 (230)	4.3 (110)	8.7 (220)	38.9 (988)	30 (762)	22.3 (567)	4.3 (110)	2.4 (60)	47.8 (1214)	3.5 (90)	9.4 (240)
SLV.30.A30.250.2.52H	20.7 (525)	15.2 (385)	8 x M20	44.3 (1124)	9.1 (230)	4.3 (110)	8.7 (220)	38.9 (988)	30 (762)	22.3 (567)	4.3 (110)	2.4 (60)	47.8 (1214)	3.5 (90)	9.4 (240)
SLV.30.A30.300.2.52H	20.7 (525)	15.2 (385)	8 x M20	44.3 (1124)	9.1 (230)	4.3 (110)	8.7 (220)	38.9 (988)	30 (762)	22.3 (567)	4.3 (110)	2.4 (60)	47.8 (1214)	3.5 (90)	9.4 (240)
SLV.30.A30.335.2.52H	20.7 (525)	15.2 (385)	8 x M20	44.3 (1124)	9.1 (230)	4.3 (110)	8.7 (220)	38.9 (988)	30 (762)	22.3 (567)	4.3 (110)	2.4 (60)	47.8 (1214)	3.5 (90)	9.4 (240)
SLV.30.A30.390.2.52H	20.7 (525)	15.2 (385)	8 x M20	44.3 (1124)	9.1 (230)	4.3 (110)	8.7 (220)	38.9 (988)	30 (762)	22.3 (567)	4.3 (110)	2.4 (60)	47.8 (1214)	3.5 (90)	9.4 (240)
SLV.30.A30.420.2.52H	20.7 (525)	15.2 (385)	8 x M20	44.3 (1124)	9.1 (230)	4.3 (110)	8.7 (220)	38.9 (988)	30 (762)	22.3 (567)	4.3 (110)	2.4 (60)	47.8 (1214)	3.5 (90)	9.4 (240)

SL/SL1/SL2/SLV [in (mm)] (part 2)

Pump type SL1/SL2/SLV	Z13	Z14	Z15	Z16	Z17G	Z17S	Z23	Z23 Ex.	S3OPR	S3OPR Ex.	ZDC1	ZDN1	ZDT1	ZL1	ZL2	ZM [Qty x mm]
SL1.30.A40.175.2.52S	0	0	8.7 (220)	16.3 (413)	0.1 (2.9)	0.1 (2.8)	33.5 (851)	33.5 (851)	37.8 (961)	37.8 (961)	7.5 (190)	4"	0.8 (21)	17.4 (443)	4.2 (107)	4 x M16
SL.A40.175.2.52S	0	0	8.7 (220)	16.3 (413)	0.1 (2.9)	0.1 (2.8)	33.7 (855)	33.7 (855)	37.3 (947)	37.3 (947)	7.5 (190)	4"	0.8 (21)	17.4 (443)	4.2 (107)	4 x M16
SL1.30.A40.200.2.52S	0	0	8.7 (220)	16.3 (413)	0.1 (2.9)	0.1 (2.8)	33.5 (851)	33.5 (851)	37.8 (961)	37.8 (961)	7.5 (190)	4"	0.8 (21)	17.4 (443)	4.2 (107)	4 x M16
SL.A40.200.2.52S	0	0	8.7 (220)	16.3 (413)	0.1 (2.9)	0.1 (2.8)	33.7 (855)	33.7 (855)	37.3 (947)	37.3 (947)	7.5 (190)	4"	0.8 (21)	17.4 (443)	4.2 (107)	4 x M16
SL1.30.A40.230.2.52S	0	0	8.7 (220)	16.3 (413)	0.1 (2.9)	0.1 (2.8)	33.5 (851)	33.5 (851)	37.8 (961)	37.8 (961)	7.5 (190)	4"	0.8 (21)	17.4 (443)	4.2 (107)	4 x M16
SL.A40.230.2.52S	0	0	8.7 (220)	16.3 (413)	0.1 (2.9)	0.1 (2.8)	33.7 (855)	33.7 (855)	37.3 (947)	37.3 (947)	7.5 (190)	4"	0.8 (21)	17.4 (443)	4.2 (107)	4 x M16

Pump type SL1/SL2/SLV	Z13	Z14	Z15	Z16	Z17G	Z17S	Z23	Z23 Ex.	S3OPR	S3OPR Ex.	ZDC1	ZDN1	ZDT1	ZL1	ZL2	ZM [Qty x mm]
SL1.30.A40.250.2.52S	0	0	8.7 (220)	16.3 (413)	0.1 (2.9)	0.1 (2.8)	33.5 (851)	33.5 (851)	37.8 (961)	37.8 (961)	7.5 (190)	4"	0.8 (21)	17.4 (443)	4.2 (107)	4 x M16
SL.A40.250.2.52S	0	0	8.7 (220)	16.3 (413)	0.1 (2.9)	0.1 (2.8)	33.7 (855)	33.7 (855)	37.3 (947)	37.3 (947)	7.5 (190)	4"	0.8 (21)	17.4 (443)	4.2 (107)	4 x M16
SL1.30.A40.120.4.52H	3.1 (80)	0	8.7 (220)	16.3 (413)	0.1 (2.9)	0.1 (2.8)	34.4 (874)	34.4 (874)	36.8 (934)	36.8 (934)	7.5 (190)	4"	0.8 (21)	17.4 (443)	4.2 (107)	4 x M16
SL.A40.120.4.52H	3.1 (80)	0	8.7 (220)	16.3 (413)	0.1 (2.9)	0.1 (2.8)	34.4 (873)	34.4 (873)	36.7 (933)	36.7 (933)	7.5 (190)	4"	0.8 (21)	17.4 (443)	4.2 (107)	4 x M16
SL1.30.A40.150.4.52H	3.1 (80)	0	8.7 (220)	16.3 (413)	0.1 (2.9)	0.1 (2.8)	34.4 (874)	34.4 (874)	36.8 (934)	36.8 (934)	7.5 (190)	4"	0.8 (21)	17.4 (443)	4.2 (107)	4 x M16
SL.A40.150.4.52H	3.1 (80)	0	8.7 (220)	16.3 (413)	0.1 (2.9)	0.1 (2.8)	34.4 (873)	34.4 (873)	36.7 (933)	36.7 (933)	7.5 (190)	4"	0.8 (21)	17.4 (443)	4.2 (107)	4 x M16
SL1.30.A40.175.4.52H	3.1 (80)	0	8.7 (220)	16.3 (413)	0.1 (2.9)	0.1 (2.8)	34.4 (874)	34.4 (874)	36.8 (934)	36.8 (934)	7.5 (190)	4"	0.8 (21)	17.4 (443)	4.2 (107)	4 x M16
SL.A40.175.4.52H	3.1 (80)	0	8.7 (220)	16.3 (413)	0.1 (2.9)	0.1 (2.8)	34.4 (873)	34.4 (873)	36.7 (933)	36.7 (933)	7.5 (190)	4"	0.8 (21)	17.4 (443)	4.2 (107)	4 x M16
SL1.30.A40.200.4.52H	3.1 (80)	0	8.7 (220)	16.3 (413)	0.1 (2.9)	0.1 (2.8)	34.4 (874)	34.4 (874)	36.8 (934)	36.8 (934)	7.5 (190)	4"	0.8 (21)	17.4 (443)	4.2 (107)	4 x M16
SL.A40.200.4.52H	3.1 (80)	0	8.7 (220)	16.3 (413)	0.1 (2.9)	0.1 (2.8)	34.4 (873)	34.4 (873)	36.7 (933)	36.7 (933)	7.5 (190)	4"	0.8 (21)	17.4 (443)	4.2 (107)	4 x M16
SL1.35.A40.245.4.52H	3.3 (84)	0	8.7 (220)	16.3 (413)	0.1 (2.9)	0.1 (2.8)	34.4 (875)	34.4 (875)	36.7 (931)	36.7 (931)	7.5 (190)	4"	0.8 (21)	17.4 (443)	4.2 (107)	4 x M16
SL.A40.245.4.52H	3.3 (84)	0	8.7 (220)	16.3 (413)	0.1 (2.9)	0.1 (2.8)	34.5 (876)	34.5 (876)	36.7 (932)	36.7 (932)	7.5 (190)	4"	0.8 (21)	17.4 (443)	4.2 (107)	4 x M16
SL1.35.A40.270.4.52H	3.3 (84)	0	8.7 (220)	16.3 (413)	0.1 (2.9)	0.1 (2.8)	34.4 (875)	34.4 (875)	36.7 (931)	36.7 (931)	7.5 (190)	4"	0.8 (21)	17.4 (443)	4.2 (107)	4 x M16
SL.A40.270.4.52H	3.3 (84)	0	8.7 (220)	16.3 (413)	0.1 (2.9)	0.1 (2.8)	34.5 (876)	34.5 (876)	36.7 (932)	36.7 (932)	7.5 (190)	4"	0.8 (21)	17.4 (443)	4.2 (107)	4 x M16
SL1.35.A40.300.4.52H	3.3 (84)	0	8.7 (220)	16.3 (413)	0.1 (2.9)	0.1 (2.8)	34.4 (875)	34.4 (875)	36.7 (931)	36.7 (931)	7.5 (190)	4"	0.8 (21)	17.4 (443)	4.2 (107)	4 x M16
SL.A40.300.4.52H	3.3 (84)	0	8.7 (220)	16.3 (413)	0.1 (2.9)	0.1 (2.8)	34.5 (876)	34.5 (876)	36.7 (932)	36.7 (932)	7.5 (190)	4"	0.8 (21)	17.4 (443)	4.2 (107)	4 x M16
SL1.35.A40.330.4.52H	3.3 (84)	0	8.7 (220)	16.3 (413)	0.1 (2.9)	0.1 (2.8)	34.4 (875)	34.4 (875)	36.7 (931)	36.7 (931)	7.5 (190)	4"	0.8 (21)	17.4 (443)	4.2 (107)	4 x M16
SL.A40.330.4.52H	3.3 (84)	0	8.7 (220)	16.3 (413)	0.1 (2.9)	0.1 (2.8)	34.5 (876)	34.5 (876)	36.7 (932)	36.7 (932)	7.5 (190)	4"	0.8 (21)	17.4 (443)	4.2 (107)	4 x M16
SL1.30.A60.120.4.52H	0	0	11 (280)	17.7 (450)	0.1 (3.2)	0.1 (3.1)	34.4 (874)	34.4 (874)	35.8 (979)	35.8 (979)	9.4 (240)	6"	0.9 (22)	21.7 (552)	5.1 (129)	4 x M16
SL.A60.120.4.52H	0	0	11 (280)	17.7 (450)	0.1 (3.2)	0.1 (3.1)	34.4 (873)	34.4 (873)	38.5 (978)	38.5 (978)	9.4 (240)	6"	0.9 (22)	21.7 (552)	5.1 (129)	4 x M16
SL1.30.A60.150.4.52H	0	0	11 (280)	17.7 (450)	0.1 (3.2)	0.1 (3.1)	34.4 (874)	34.4 (874)	35.8 (979)	35.8 (979)	9.4 (240)	6"	0.9 (22)	21.7 (552)	5.1 (129)	4 x M16
SL.A60.150.4.52H	0	0	11 (280)	17.7 (450)	0.1 (3.2)	0.1 (3.1)	34.4 (873)	34.4 (873)	38.5 (978)	38.5 (978)	9.4 (240)	6"	0.9 (22)	21.7 (552)	5.1 (129)	4 x M16
SL1.30.A60.175.4.52H	0	0	11 (280)	17.7 (450)	0.1 (3.2)	0.1 (3.1)	34.4 (874)	34.4 (874)	35.8 (979)	35.8 (979)	9.4 (240)	6"	0.9 (22)	21.7 (552)	5.1 (129)	4 x M16
SL.A60.175.4.52H	0	0	11 (280)	17.7 (450)	0.1 (3.2)	0.1 (3.1)	34.4 (873)	34.4 (873)	38.5 (978)	38.5 (978)	9.4 (240)	6"	0.9 (22)	21.7 (552)	5.1 (129)	4 x M16
SL1.30.A60.200.4.52H	0	0	11 (280)	17.7 (450)	0.1 (3.2)	0.1 (3.1)	34.4 (874)	34.4 (874)	35.8 (979)	35.8 (979)	9.4 (240)	6"	0.9 (22)	21.7 (552)	5.1 (129)	4 x M16
SL.A60.200.4.52H	0	0	11 (280)	17.7 (450)	0.1 (3.2)	0.1 (3.1)	34.4 (873)	34.4 (873)	38.5 (978)	38.5 (978)	9.4 (240)	6"	0.9 (22)	21.7 (552)	5.1 (129)	4 x M16
SL1.35.A60.245.4.52H	0	0	11 (280)	17.7 (450)	0.1 (3.2)	0.1 (3.1)	34.4 (874)	34.4 (874)	38.4 (976)	38.4 (976)	9.4 (240)	6"	0.9 (22)	21.7 (552)	5.1 (129)	4 x M16

Pump type SL1/SL2/SLV	Z13	Z14	Z15	Z16	Z17G	Z17S	Z23	Z23 Ex.	S3OPR	S3OPR Ex.	ZDC1	ZDN1	ZDT1	ZL1	ZL2	ZM [Qty x mm]
SL.A60.245.4.52H	0	0	11 (280)	17.7 (450)	0.1 (3.2)	0.1 (3.1)	34.5 (876)	34.5 (876)	38.5 (978)	38.5 (978)	9.4 (240)	6"	0.9 (22)	21.7 (552)	5.1 (129)	4 x M16
SL1.35.A60.270.4.52H	0	0	11 (280)	17.7 (450)	0.1 (3.2)	0.1 (3.1)	34.4 (874)	34.4 (874)	38.4 (976)	38.4 (976)	9.4 (240)	6"	0.9 (22)	21.7 (552)	5.1 (129)	4 x M16
SL.A60.270.4.52H	0	0	11 (280)	17.7 (450)	0.1 (3.2)	0.1 (3.1)	34.5 (876)	34.5 (876)	38.5 (978)	38.5 (978)	9.4 (240)	6"	0.9 (22)	21.7 (552)	5.1 (129)	4 x M16
SL1.35.A60.300.4.52H	0	0	11 (280)	17.7 (450)	0.1 (3.2)	0.1 (3.1)	34.4 (874)	34.4 (874)	38.4 (976)	38.4 (976)	9.4 (240)	6"	0.9 (22)	21.7 (552)	5.1 (129)	4 x M16
SL.A60.300.4.52H	0	0	11 (280)	17.7 (450)	0.1 (3.2)	0.1 (3.1)	34.5 (876)	34.5 (876)	38.5 (978)	38.5 (978)	9.4 (240)	6"	0.9 (22)	21.7 (552)	5.1 (129)	4 x M16
SL1.35.A60.330.4.52H	0	0	11 (280)	17.7 (450)	0.1 (3.2)	0.1 (3.1)	34.4 (874)	34.4 (874)	38.4 (976)	38.4 (976)	9.4 (240)	6"	0.9 (22)	21.7 (552)	5.1 (129)	4 x M16
SL1.40.A80.120.4.52M	4.3 (108)	3.4 (86)	14.4 (365)	19.1 (485)	0.1 (3.2)	0.1 (3.1)	35.2 (893)	35.2 (893)	36.4 (925)	36.4 (925)	11.7 (298)	8"	1.2 (31)	30 (761)	8.8 (223)	4 x M24
SL1.40.A80.150.4.52M	4.3 (108)	3.4 (86)	14.4 (365)	19.1 (485)	0.1 (3.2)	0.1 (3.1)	35.2 (893)	35.2 (893)	36.4 (925)	36.4 (925)	11.7 (298)	8"	1.2 (31)	30 (761)	8.8 (223)	4 x M24
SL1.40.A80.175.4.52M	4.3 (108)	3.4 (86)	14.4 (365)	19.1 (485)	0.1 (3.2)	0.1 (3.1)	35.2 (893)	35.2 (893)	36.4 (925)	36.4 (925)	11.7 (298)	8"	1.2 (31)	30 (761)	8.8 (223)	4 x M24
SL1.40.A80.200.4.52M	4.3 (108)	3.4 (86)	14.4 (365)	19.1 (485)	0.1 (3.2)	0.1 (3.1)	35.2 (893)	35.2 (893)	36.4 (925)	36.4 (925)	11.7 (298)	8"	1.2 (31)	30 (761)	8.8 (223)	4 x M24
SL1.45.A80.245.4.52M	5.2 (131)	3.4 (86)	14.4 (365)	19.1 (485)	0.1 (3.2)	0.1 (3.1)	35.6 (903)	35.6 (903)	35.9 (912)	35.9 (912)	11.7 (298)	8"	1.2 (31)	30 (761)	8.8 (223)	4 x M24
SL1.45.A80.270.4.52M	5.2 (131)	3.4 (86)	14.4 (365)	19.1 (485)	0.1 (3.2)	0.1 (3.1)	35.6 (903)	35.6 (903)	35.9 (912)	35.9 (912)	11.7 (298)	8"	1.2 (31)	30 (761)	8.8 (223)	4 x M24
SL1.45.A80.300.4.52M	5.2 (131)	3.4 (86)	14.4 (365)	19.1 (485)	0.1 (3.2)	0.1 (3.1)	35.6 (903)	35.6 (903)	35.9 (912)	35.9 (912)	11.7 (298)	8"	1.2 (31)	30 (761)	8.8 (223)	4 x M24
SL1.45.A80.330.4.52M	5.2 (131)	3.4 (86)	14.4 (365)	19.1 (485)	0.1 (3.2)	0.1 (3.1)	35.6 (903)	35.6 (903)	35.9 (912)	35.9 (912)	11.7 (298)	8"	1.2 (31)	30 (761)	8.8 (223)	4 x M24
SL2.45.A100.150.4.52L	4.5 (114)	3.4 (86)	14.8 (375)	21.5 (545)	0.1 (3.2)	0.1 (3.1)	36.1 (917)	36.1 (917)	37.1 (943)	37.1 (943)	14.3 (362)	10"	1.3 (32)	31.3 (795)	8.9 (226)	4 x M24
SL2.45.A100.175.4.52L	4.5 (114)	3.4 (86)	14.8 (375)	21.5 (545)	0.1 (3.2)	0.1 (3.1)	36.1 (917)	36.1 (917)	37.1 (943)	37.1 (943)	14.3 (362)	10"	1.3 (32)	31.3 (795)	8.9 (226)	4 x M24
SL2.45.A100.200.4.52L	4.5 (114)	3.4 (86)	14.8 (375)	21.5 (545)	0.1 (3.2)	0.1 (3.1)	36.1 (917)	36.1 (917)	37.1 (943)	37.1 (943)	14.3 (362)	10"	1.3 (32)	31.3 (795)	8.9 (226)	4 x M24
SL2.45.A100.245.4.52L	4.5 (114)	3.4 (86)	14.8 (375)	21.5 (545)	0.1 (3.2)	0.1 (3.1)	36.1 (917)	36.1 (917)	37.1 (943)	37.1 (943)	14.3 (362)	10"	1.3 (32)	31.3 (795)	8.9 (226)	4 x M24
SL2.45.A100.270.4.52L	4.5 (114)	3.4 (86)	14.8 (375)	21.5 (545)	0.1 (3.2)	0.1 (3.1)	36.1 (917)	36.1 (917)	37.1 (943)	37.1 (943)	14.3 (362)	10"	1.3 (32)	31.3 (795)	8.9 (226)	4 x M24
SL2.45.A100.300.4.52L	4.5 (114)	3.4 (86)	14.8 (375)	21.5 (545)	0.1 (3.2)	0.1 (3.1)	36.1 (917)	36.1 (917)	37.1 (943)	37.1 (943)	14.3 (362)	10"	1.3 (32)	31.3 (795)	8.9 (226)	4 x M24
SL2.45.A100.330.4.52L	4.5 (114)	3.4 (86)	14.8 (375)	21.5 (545)	0.1 (3.2)	0.1 (3.1)	36.1 (917)	36.1 (917)	37.1 (943)	37.1 (943)	14.3 (362)	10"	1.3 (32)	31.3 (795)	8.9 (226)	4 x M24
SL2.45.A100.110.6.52E	4.5 (114)	3.4 (86)	14.8 (375)	21.5 (545)	0.1 (3.2)	0.1 (3.1)	36.1 (917)	36.1 (917)	37.1 (943)	37.1 (943)	14.3 (362)	10"	1.3 (32)	31.3 (795)	8.9 (226)	4 x M24
SL2.45.A100.135.6.52E	4.5 (114)	3.4 (86)	14.8 (375)	21.5 (545)	0.1 (3.2)	0.1 (3.1)	36.1 (917)	36.1 (917)	37.1 (943)	37.1 (943)	14.3 (362)	10"	1.3 (32)	31.3 (795)	8.9 (226)	4 x M24
SL2.45.A100.160.6.52E	4.5 (114)	3.4 (86)	14.8 (375)	21.5 (545)	0.1 (3.2)	0.1 (3.1)	36.1 (917)	36.1 (917)	37.1 (943)	37.1 (943)	14.3 (362)	10"	1.3 (32)	31.3 (795)	8.9 (226)	4 x M24
SL2.50.A120.190.6.52E	4.5 (114)	3.7 (95)	17.7 (450)	25.6 (650)	0.1 (3.2)	0.1 (3.1)	38.1 (969)	38.1 (969)	39.2 (995)	39.2 (995)	17 (432)	12"	1.3 (32)	35.2 (895)	8.9 (226)	4 x M24
SL2.50.A120.215.6.52E	4.5 (114)	3.7 (95)	17.7 (450)	25.6 (650)	0.1 (3.2)	0.1 (3.1)	38.1 (969)	38.1 (969)	39.2 (995)	39.2 (995)	17 (432)	12"	1.3 (32)	35.2 (895)	8.9 (226)	4 x M24
SL2.50.A120.255.6.52E	4.5 (114)	3.7 (95)	17.7 (450)	25.6 (650)	0.1 (3.2)	0.1 (3.1)	38.1 (969)	38.1 (969)	39.2 (995)	39.2 (995)	17 (432)	12"	1.3 (32)	35.2 (895)	8.9 (226)	4 x M24

Pump type SL1/SL2/SLV	Z13	Z14	Z15	Z16	Z17G	Z17S	Z23	Z23 Ex.	S3OPR	S3OPR Ex.	ZDC1	ZDN1	ZDT1	ZL1	ZL2	ZM [Qty x mm]
SLV.30.A30.175.2.52H	0	0	8.7 (220)	16.3 (413)	0.1 (2.9)	0.1 (2.8)	33 (839)	33 (839)	36.6 (929)	36.6 (929)	7.5 (190)	4"	0.8 (21)	18.2 (463)	5 (127)	4 x M16
SLV.30.A30.200.2.52H	0	0	8.7 (220)	16.3 (413)	0.1 (2.9)	0.1 (2.8)	33 (839)	33 (839)	36.6 (929)	36.6 (929)	7.5 (190)	4"	0.8 (21)	18.2 (463)	5 (127)	4 x M16
SLV.30.A30.230.2.52H	0	0	8.7 (220)	16.3 (413)	0.1 (2.9)	0.1 (2.8)	33 (839)	33 (839)	36.6 (929)	36.6 (929)	7.5 (190)	4"	0.8 (21)	18.2 (463)	5 (127)	4 x M16
SLV.30.A30.250.2.52H	0	0	8.7 (220)	16.3 (413)	0.1 (2.9)	0.1 (2.8)	33 (839)	33 (839)	36.6 (929)	36.6 (929)	7.5 (190)	4"	0.8 (21)	18.2 (463)	5 (127)	4 x M16
SLV.30.A30.300.2.52H	0	0	8.7 (220)	16.3 (413)	0.1 (2.9)	0.1 (2.8)	33 (839)	33 (839)	36.6 (929)	36.6 (929)	7.5 (190)	4"	0.8 (21)	18.2 (463)	5 (127)	4 x M16
SLV.30.A30.335.2.52H	0	0	8.7 (220)	16.3 (413)	0.1 (2.9)	0.1 (2.8)	33 (839)	33 (839)	36.6 (929)	36.6 (929)	7.5 (190)	4"	0.8 (21)	18.2 (463)	5 (127)	4 x M16
SLV.30.A30.390.2.52H	0	0	8.7 (220)	16.3 (413)	0.1 (2.9)	0.1 (2.8)	33 (839)	33 (839)	36.6 (929)	36.6 (929)	7.5 (190)	4"	0.8 (21)	18.2 (463)	5 (127)	4 x M16
SLV.30.A30.420.2.52H	0	0	8.7 (220)	16.3 (413)	0.1 (2.9)	0.1 (2.8)	33 (839)	33 (839)	36.6 (929)	36.6 (929)	7.5 (190)	4"	0.8 (21)	18.2 (463)	5 (127)	4 x M16

Dry, vertical installation

Installation on vertical base stand

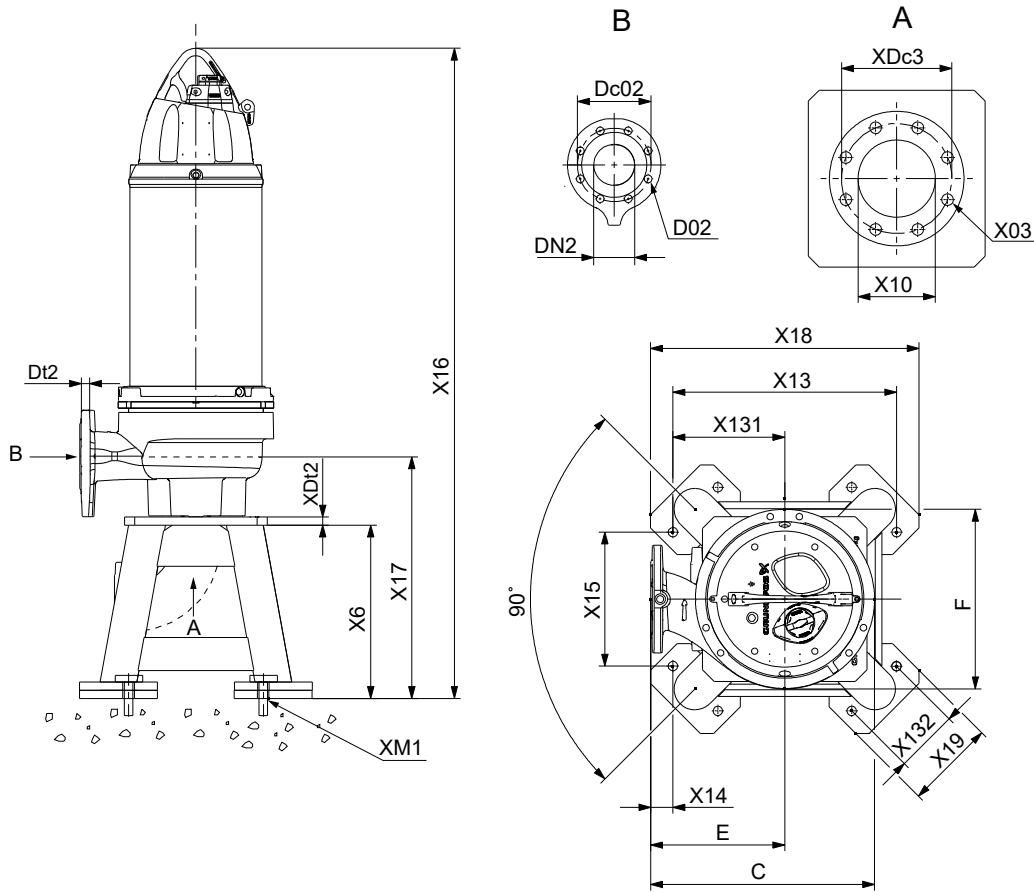

TM084519

Vertical base stand dimensions

SE/SE1/SEV [in (mm)] (part 1)

Pump type SE1/SEV	C	E	F	X6	X10	X13	X14	X15	X16	X17	X18
SE1.30.A40.175.2.52S	18.8 (478)	11.2 (285)	15.2 (386)	16.7 (425)	4"	18.7 (475)	1.9 (47)	11.2 (285)	62.8 (1595)	22.7 (576)	22.5 (571)
SE.A40.175.2.52S	18.7 (476)	11.2 (285)	15 (382)	16.7 (425)	4"	18.7 (475)	1.9 (47)	11.2 (285)	62.8 (1595)	23.4 (594)	22.5 (571)
SEV.30.A30.175.2.52H	20.7 (527)	13 (330)	15.5 (394)	16.7 (425)	4"	18.7 (475)	3.6 (92)	11.2 (285)	62.2 (1580)	23.5 (596)	22.5 (571)
SE1.30.A40.120.4.52H	23.2 (590)	15 (380)	16.8 (427)	23.5 (596)	6"	28.2 (716)	0.9 (22)	19.1 (484)	70.5 (1790)	31.5 (801)	31.8 (808)
SE.A40.120.4.52H	23.2 (590)	15 (380)	16.8 (427)	23.5 (596)	6"	28.2 (716)	0.9 (22)	19.1 (484)	70.4 (1789)	31.5 (801)	31.8 (808)
SE1.30.A40.150.4.52H	23.2 (590)	15 (380)	16.8 (427)	23.5 (596)	6"	28.2 (716)	0.9 (22)	19.1 (484)	70.5 (1790)	31.5 (801)	31.8 (808)
SE.A40.150.4.52H	23.2 (590)	15 (380)	16.8 (427)	23.5 (596)	6"	28.2 (716)	0.9 (22)	19.1 (484)	70.4 (1789)	31.5 (801)	31.8 (808)
SE1.30.A40.175.4.52H	23.2 (590)	15 (380)	16.8 (427)	23.5 (596)	6"	28.2 (716)	0.9 (22)	19.1 (484)	70.5 (1790)	31.5 (801)	31.8 (808)

Pump type SE1/SEV	C	E	F	X6	X10	X13	X14	X15	X16	X17	X18
SE.A40.175.4.52H	23.2 (590)	15 (380)	16.8 (427)	23.5 (596)	6"	28.2 (716)	0.9 (22)	19.1 (484)	70.4 (1789)	31.5 (801)	31.8 (808)
SE1.30.A60.120.4.52H	22 (558)	13.8 (350)	16.7 (424)	23.5 (596)	6"	28.2 (716)	0.3 (8)	19.1 (484)	70.5 (1790)	31.1 (791)	31.8 (808)
SE.A60.120.4.52H	22 (558)	13.8 (350)	16.7 (424)	23.5 (596)	6"	28.2 (716)	0.3 (8)	19.1 (484)	70.4 (1789)	31.1 (791)	31.8 (808)
SE1.30.A60.150.4.52H	22 (558)	13.8 (350)	16.7 (424)	23.5 (596)	6"	28.2 (716)	0.3 (8)	19.1 (484)	70.5 (1790)	31.1 (791)	31.8 (808)
SE.A60.150.4.52H	22 (558)	13.8 (350)	16.7 (424)	23.5 (596)	6"	28.2 (716)	0.3 (8)	19.1 (484)	70.4 (1789)	31.1 (791)	31.8 (808)
SE1.30.A60.175.4.52H	22 (558)	13.8 (350)	16.7 (424)	23.5 (596)	6"	28.2 (716)	0.3 (8)	19.1 (484)	70.5 (1790)	31.1 (791)	31.8 (808)
SE.A60.175.4.52H	22 (558)	13.8 (350)	16.7 (424)	23.5 (596)	6"	28.2 (716)	0.3 (8)	19.1 (484)	70.4 (1789)	31.1 (791)	31.8 (808)
SE1.40.A80.120.4.52M	29 (737)	19.7 (500)	18.5 (471)	27.3 (694)	8"	30.2 (766)	4.6 (117)	21 (534)	75.1 (1907)	34.8 (883)	33.8 (858)
SE1.40.A80.150.4.52M	29 (737)	19.7 (500)	18.5 (471)	27.3 (694)	8"	30.2 (766)	4.6 (117)	21 (534)	75.1 (1907)	34.8 (883)	33.8 (858)
SE1.40.A80.175.4.52M	29 (737)	19.7 (500)	18.5 (471)	27.3 (694)	8"	30.2 (766)	4.6 (117)	21 (534)	75.1 (1907)	34.8 (883)	33.8 (858)
SE2.45.A100.150.4.52L	33.4 (849)	19.7 (500)	26.8 (680)	32.4 (824)	10"	35.7 (906)	1.9 (47)	23.4 (594)	81.3 (2065)	41.4 (1051)	39.6 (1005)
SE2.45.A100.175.4.52L	33.4 (849)	19.7 (500)	26.8 (680)	32.4 (824)	10"	35.7 (906)	1.9 (47)	23.4 (594)	81.3 (2065)	41.4 (1051)	39.6 (1005)
SE2.45.A100.110.6.52E	33.4 (849)	19.7 (500)	26.8 (680)	32.4 (824)	10"	35.7 (906)	1.9 (47)	23.4 (594)	81.3 (2065)	41.4 (1051)	39.6 (1005)
SE2.45.A100.135.6.52E	33.4 (849)	19.7 (500)	26.8 (680)	32.4 (824)	10"	35.7 (906)	1.9 (47)	23.4 (594)	81.3 (2065)	41.4 (1051)	39.6 (1005)
SE2.45.A100.160.6.52E	33.4 (849)	19.7 (500)	26.8 (680)	32.4 (824)	10"	35.7 (906)	1.9 (47)	23.4 (594)	81.3 (2065)	41.4 (1051)	39.6 (1005)
SE2.50.A120.190.6.52E	37.5 (950)	23.6 (600)	27.4 (696)	33.5 (852)	12"	35.7 (906)	5.8 (147)	23.4 (594)	84.5 (2146)	43.8 (1112)	39.6 (1005)

SE/SE1/SEV [in (mm)] (part 2)

Pump type SE1/SEV	X19	X131	X132	XM1	XDt2	XDc3	X03	Dt2	DN2	Dc02	D02
SE1.30.A40.175.2.52S	7.5 (190)	9.4 (238)	5.3 (135)	8 x M16	0.8 (20)	7.5 (191)	0.7 (19)	1 (25)	4"	7.5 (191)	0.7 (19)
SE.A40.175.2.52S	7.5 (190)	9.4 (238)	5.3 (135)	8 x M16	0.8 (20)	7.5 (191)	0.7 (19)	1 (25)	4"	7.5 (191)	0.7 (19)
SEV.30.A30.175.2.52H	7.5 (190)	9.4 (238)	5.3 (135)	8 x M16	0.8 (20)	7.5 (191)	0.7 (19)	1 (25)	3"	6.6 (168)	0.7 (19)
SE1.30.A40.120.4.52H	8.7 (220)	14.1 (358)	6.5 (164)	8 x M20	1 (25)	9.4 (240)	0.9 (24)	0.9 (24)	4"	7.5 (191)	0.7 (19)
SE.A40.120.4.52H	8.7 (220)	14.1 (358)	6.5 (164)	8 x M20	1 (25)	9.4 (240)	0.9 (24)	0.9 (24)	4"	7.5 (191)	0.7 (19)
SE1.30.A40.150.4.52H	8.7 (220)	14.1 (358)	6.5 (164)	8 x M20	1 (25)	9.4 (240)	0.9 (24)	0.9 (24)	4"	7.5 (191)	0.7 (19)
SE.A40.150.4.52H	8.7 (220)	14.1 (358)	6.5 (164)	8 x M20	1 (25)	9.4 (240)	0.9 (24)	0.9 (24)	4"	7.5 (191)	0.7 (19)
SE1.30.A40.175.4.52H	8.7 (220)	14.1 (358)	6.5 (164)	8 x M20	1 (25)	9.4 (240)	0.9 (24)	0.9 (24)	4"	7.5 (191)	0.7 (19)

Pump type SE1/SEV	X19	X131	X132	XM1	XDt2	XDc3	X03	Dt2	DN2	Dc02	D02
SE.A40.175.4.52H	8.7 (220)	14.1 (358)	6.5 (164)	8 x M20	1 (25)	9.4 (240)	0.9 (24)	0.9 (24)	4"	7.5 (191)	0.7 (19)
SE1.30.A60.120.4.52H	8.7 (220)	14.1 (358)	6.5 (164)	8 x M20	1 (25)	9.4 (240)	0.9 (24)	1.1 (27)	6"	9.4 (240)	0.9 (23)
SE.A60.120.4.52H	8.7 (220)	14.1 (358)	6.5 (164)	8 x M20	1 (25)	9.4 (240)	0.9 (24)	1.1 (27)	6"	9.4 (240)	0.9 (23)
SE1.30.A60.150.4.52H	8.7 (220)	14.1 (358)	6.5 (164)	8 x M20	1 (25)	9.4 (240)	0.9 (24)	1.1 (27)	6"	9.4 (240)	0.9 (23)
SE.A60.150.4.52H	8.7 (220)	14.1 (358)	6.5 (164)	8 x M20	1 (25)	9.4 (240)	0.9 (24)	1.1 (27)	6"	9.4 (240)	0.9 (23)
SE1.30.A60.175.4.52H	8.7 (220)	14.1 (358)	6.5 (164)	8 x M20	1 (25)	9.4 (240)	0.9 (24)	1.1 (27)	6"	9.4 (240)	0.9 (23)
SE.A60.175.4.52H	8.7 (220)	14.1 (358)	6.5 (164)	8 x M20	1 (25)	9.4 (240)	0.9 (24)	1.1 (27)	6"	9.4 (240)	0.9 (23)
SE1.40.A80.120.4.52M	8.7 (220)	15.1 (383)	6.5 (164)	8 x M20	1 (25)	11.7 (297)	1.1 (27)	1.2 (30)	8"	11.7 (297)	0.9 (23)
SE1.40.A80.150.4.52M	8.7 (220)	15.1 (383)	6.5 (164)	8 x M20	1 (25)	11.7 (297)	1.1 (27)	1.2 (30)	8"	11.7 (297)	0.9 (23)
SE1.40.A80.175.4.52M	8.7 (220)	15.1 (383)	6.5 (164)	8 x M20	1 (25)	11.7 (297)	1.1 (27)	1.2 (30)	8"	11.7 (297)	0.9 (23)
SE2.45.A100.150.4.52L	10.6 (270)	17.8 (453)	8.7 (220)	8 x M20	1.2 (30)	14.3 (362)	0.9 (24)	1.3 (32)	10"	14.3 (362)	0.9 (23)
SE2.45.A100.175.4.52L	10.6 (270)	17.8 (453)	8.7 (220)	8 x M20	1.2 (30)	14.3 (362)	0.9 (24)	1.3 (32)	10"	14.3 (362)	0.9 (23)
SE2.45.A100.110.6.52E	10.6 (270)	17.8 (453)	8.7 (220)	8 x M20	1.2 (30)	14.3 (362)	0.9 (24)	1.3 (32)	10"	14.3 (362)	0.9 (23)
SE2.45.A100.135.6.52E	10.6 (270)	17.8 (453)	8.7 (220)	8 x M20	1.2 (30)	14.3 (362)	0.9 (24)	1.3 (32)	10"	14.3 (362)	0.9 (23)
SE2.45.A100.160.6.52E	10.6 (270)	17.8 (453)	8.7 (220)	8 x M20	1.2 (30)	14.3 (362)	0.9 (24)	1.3 (32)	10"	14.3 (362)	0.9 (23)
SE2.50.A120.190.6.52E	10.6 (270)	17.8 (453)	8.7 (220)	8 x M20	1.2 (30)	17 (432)	1 (26)	1.3 (32)	12"	17 (432)	1 (25)

Pump type	C	E	X02	X03	X04	X1	X2	X3	X4	X5	X6	X7
SE.A40.420.2.52S	19.04 (476)	11.4 (285)	0.76 (19)	0.72 (18)	1.12 (28)	46.08 (1152)	6.84 (171)	0.8 (20)	8.12 (203)	9.6 (240)	17.72 (443)	20 (500)
SEV.30.A30.200.2.52H	21.08 (527)	13.2 (330)	0.76 (19)	0.72 (18)	1.12 (28)	45.48 (1137)	6.92 (173)	0.8 (20)	8.12 (203)	9.6 (240)	17.72 (443)	20 (500)
SEV.30.A30.230.2.52H	21.08 (527)	13.2 (330)	0.76 (19)	0.72 (18)	1.12 (28)	45.48 (1137)	6.92 (173)	0.8 (20)	8.12 (203)	9.6 (240)	17.72 (443)	20 (500)
SEV.30.A30.250.2.52H	21.08 (527)	13.2 (330)	0.76 (19)	0.72 (18)	1.12 (28)	45.48 (1137)	6.92 (173)	0.8 (20)	8.12 (203)	9.6 (240)	17.72 (443)	20 (500)
SEV.30.A30.300.2.52H	21.08 (527)	13.2 (330)	0.76 (19)	0.72 (18)	1.12 (28)	45.48 (1137)	6.92 (173)	0.8 (20)	8.12 (203)	9.6 (240)	17.72 (443)	20 (500)
SEV.30.A30.335.2.52H	21.08 (527)	13.2 (330)	0.76 (19)	0.72 (18)	1.12 (28)	45.48 (1137)	6.92 (173)	0.8 (20)	8.12 (203)	9.6 (240)	17.72 (443)	20 (500)
SEV.30.A30.390.2.52H	21.08 (527)	13.2 (330)	0.76 (19)	0.72 (18)	1.12 (28)	45.48 (1137)	6.92 (173)	0.8 (20)	8.12 (203)	9.6 (240)	17.72 (443)	20 (500)
SEV.30.A30.420.2.52H	21.08 (527)	13.2 (330)	0.76 (19)	0.72 (18)	1.12 (28)	45.48 (1137)	6.92 (173)	0.8 (20)	8.12 (203)	9.6 (240)	17.72 (443)	20 (500)
SE1.30.A40.200.4.52H	23.6 (590)	15.2 (380)	0.76 (19)	0.92 (23)	1.12 (28)	46.84 (1171)	8.12 (203)	0.8 (20)	10.12 (253)	14.72 (368)	24.84 (621)	20 (500)
SE.A40.200.4.52H	23.6 (590)	15.2 (380)	0.76 (19)	0.92 (23)	1.12 (28)	46.8 (1170)	8.12 (203)	0.8 (20)	10.12 (253)	14.72 (368)	24.84 (621)	20 (500)
SE1.35.A40.245.4.52H	24.36 (609)	15.2 (380)	0.76 (19)	0.92 (23)	1.12 (28)	46.88 (1172)	8.28 (207)	0.8 (20)	10.12 (253)	14.72 (368)	24.84 (621)	20 (500)
SE.A40.245.4.52H	24.36 (609)	15.2 (380)	0.76 (19)	0.92 (23)	1.12 (28)	46.92 (1173)	8.28 (207)	0.8 (20)	10.12 (253)	14.72 (368)	24.84 (621)	20 (500)
SE1.35.A40.270.4.52H	24.36 (609)	15.2 (380)	0.76 (19)	0.92 (23)	1.12 (28)	46.88 (1172)	8.28 (207)	0.8 (20)	10.12 (253)	14.72 (368)	24.84 (621)	20 (500)
SE.A40.270.4.52H	24.36 (609)	15.2 (380)	0.76 (19)	0.92 (23)	1.12 (28)	46.92 (1173)	8.28 (207)	0.8 (20)	10.12 (253)	14.72 (368)	24.84 (621)	20 (500)
SE1.35.A40.300.4.52H	24.36 (609)	15.2 (380)	0.76 (19)	0.92 (23)	1.12 (28)	46.88 (1172)	8.28 (207)	0.8 (20)	10.12 (253)	14.72 (368)	24.84 (621)	20 (500)
SE.A40.300.4.52H	24.36 (609)	15.2 (380)	0.76 (19)	0.92 (23)	1.12 (28)	46.92 (1173)	8.28 (207)	0.8 (20)	10.12 (253)	14.72 (368)	24.84 (621)	20 (500)
SE1.35.A40.330.4.52H	24.36 (609)	15.2 (380)	0.76 (19)	0.92 (23)	1.12 (28)	46.88 (1172)	8.28 (207)	0.8 (20)	10.12 (253)	14.72 (368)	24.84 (621)	20 (500)
SE.A40.330.4.52H	24.36 (609)	15.2 (380)	0.76 (19)	0.92 (23)	1.12 (28)	46.92 (1173)	8.28 (207)	0.8 (20)	10.12 (253)	14.72 (368)	24.84 (621)	20 (500)
SE1.30.A60.200.4.52H	22.32 (558)	14 (350)	0.92 (23)	0.92 (23)	1.12 (28)	46.72 (1168)	7.72 (193)	0.8 (20)	10.12 (253)	14.72 (368)	24.84 (621)	20 (500)
SE.A60.200.4.52H	22.32 (558)	14 (350)	0.92 (23)	0.92 (23)	1.12 (28)	46.8 (1170)	7.72 (193)	0.8 (20)	10.12 (253)	14.72 (368)	24.84 (621)	20 (500)
SE1.35.A60.245.4.52H	24.2 (605)	15.2 (380)	0.92 (23)	0.92 (23)	1.12 (28)	46.76 (1169)	7.84 (196)	0.8 (20)	10.12 (253)	14.72 (368)	24.84 (621)	20 (500)
SE.A60.245.4.52H	24.2 (605)	15.2 (380)	0.92 (23)	0.92 (23)	1.12 (28)	46.92 (1173)	7.84 (196)	0.8 (20)	10.12 (253)	14.72 (368)	24.84 (621)	20 (500)
SE1.35.A60.270.4.52H	24.2 (605)	15.2 (380)	0.92 (23)	0.92 (23)	1.12 (28)	46.76 (1169)	7.84 (196)	0.8 (20)	10.12 (253)	14.72 (368)	24.84 (621)	20 (500)
SE.A60.270.4.52H	24.2 (605)	15.2 (380)	0.92 (23)	0.92 (23)	1.12 (28)	46.92 (1173)	7.84 (196)	0.8 (20)	10.12 (253)	14.72 (368)	24.84 (621)	20 (500)
SE1.35.A60.300.4.52H	24.2 (605)	15.2 (380)	0.92 (23)	0.92 (23)	1.12 (28)	46.76 (1169)	7.84 (196)	0.8 (20)	10.12 (253)	14.72 (368)	24.84 (621)	20 (500)

Pump type	C	E	X02	X03	X04	X1	X2	X3	X4	X5	X6	X7
SE.A60.300.4.52H	24.2 (605)	15.2 (380)	0.92 (23)	0.92 (23)	1.12 (28)	46.92 (1173)	7.84 (196)	0.8 (20)	10.12 (253)	14.72 (368)	24.84 (621)	20 (500)
SE1.35.A60.330.4.52H	24.2 (605)	15.2 (380)	0.92 (23)	0.92 (23)	1.12 (28)	46.76 (1169)	7.84 (196)	0.8 (20)	10.12 (253)	14.72 (368)	24.84 (621)	20 (500)
SE.A60.330.4.52H	24.2 (605)	15.2 (380)	0.92 (23)	0.92 (23)	1.12 (28)	46.92 (1173)	7.84 (196)	0.8 (20)	10.12 (253)	14.72 (368)	24.84 (621)	20 (500)
SE1.40.A80.200.4.52M	29.48 (737)	20 (500)	0.92 (23)	0.92 (23)	1.12 (28)	47.48 (1187)	7.48 (187)	0.8 (20)	12.12 (303)	15.88 (397)	28 (700)	20 (500)
SE1.45.A80.245.4.52M	30.24 (756)	20 (500)	0.92 (23)	0.92 (23)	1.12 (28)	47.88 (1197)	8.4 (210)	0.8 (20)	12.12 (303)	15.88 (397)	28 (700)	20 (500)
SE1.45.A80.270.4.52M	30.24 (756)	20 (500)	0.92 (23)	0.92 (23)	1.12 (28)	47.88 (1197)	8.4 (210)	0.8 (20)	12.12 (303)	15.88 (397)	28 (700)	20 (500)
SE1.45.A80.300.4.52M	30.24 (756)	20 (500)	0.92 (23)	0.92 (23)	1.12 (28)	47.88 (1197)	8.4 (210)	0.8 (20)	12.12 (303)	15.88 (397)	28 (700)	20 (500)
SE1.45.A80.330.4.52M	30.24 (756)	20 (500)	0.92 (23)	0.92 (23)	1.12 (28)	47.88 (1197)	8.4 (210)	0.8 (20)	12.12 (303)	15.88 (397)	28 (700)	20 (500)
SE2.45.A100.200.4.52L	33.96 (849)	20 (500)	0.92 (23)	0.92 (23)	1.08 (27)	48.44 (1211)	8.92 (223)	0.92 (23)	14 (350)	14.76 (369)	28.76 (719)	20 (500)
SE2.45.A100.245.4.52L	33.96 (849)	20 (500)	0.92 (23)	0.92 (23)	1.08 (27)	48.44 (1211)	8.92 (223)	0.92 (23)	14 (350)	14.76 (369)	28.76 (719)	20 (500)
SE2.45.A100.270.4.52L	33.96 (849)	20 (500)	0.92 (23)	0.92 (23)	1.08 (27)	48.44 (1211)	8.92 (223)	0.92 (23)	14 (350)	14.76 (369)	28.76 (719)	20 (500)
SE2.45.A100.300.4.52L	33.96 (849)	20 (500)	0.92 (23)	0.92 (23)	1.08 (27)	48.44 (1211)	8.92 (223)	0.92 (23)	14 (350)	14.76 (369)	28.76 (719)	20 (500)
SE2.45.A100.330.4.52L	33.96 (849)	20 (500)	0.92 (23)	0.92 (23)	1.08 (27)	48.44 (1211)	8.92 (223)	0.92 (23)	14 (350)	14.76 (369)	28.76 (719)	20 (500)
SE2.50.A120.215.6.52E	38 (950)	24 (600)	1 (25)	0.96 (24)	1.12 (28)	50.52 (1263)	10.12 (253)	0.8 (20)	16.12 (403)	15.88 (397)	32 (800)	20 (500)
SE2.50.A120.255.6.52E	38 (950)	24 (600)	1 (25)	0.96 (24)	1.12 (28)	50.52 (1263)	10.12 (253)	0.8 (20)	16.12 (403)	15.88 (397)	32 (800)	20 (500)

SE/SE1/SE2/SEV [in (mm)] (part 2)

Pump type	X8	X9	X10	X11	X12	X16	XDc3	DN2	XDc2	Dt2	XM1
SE1.30.A40.200.2.52S	36 (900)	28 (700)	4"	12 (300)	32 (800)	64.32 (1608)	7.2 (180)	4"	7.64 (191)	0.92 (23)	6 x M24
SE.A40.200.2.52S	36 (900)	28 (700)	4"	12 (300)	32 (800)	64.6 (1615)	7.2 (180)	4"	7.64 (191)	0.92 (23)	6 x M24
SE1.30.A40.230.2.52S	36 (900)	28 (700)	4"	12 (300)	32 (800)	64.32 (1608)	7.2 (180)	4"	7.64 (191)	0.92 (23)	6 x M24
SE.A40.230.2.52S	36 (900)	28 (700)	4"	12 (300)	32 (800)	64.6 (1615)	7.2 (180)	4"	7.64 (191)	0.92 (23)	6 x M24
SE1.30.A40.250.2.52S	36 (900)	28 (700)	4"	12 (300)	32 (800)	64.32 (1608)	7.2 (180)	4"	7.64 (191)	0.92 (23)	6 x M24
SE.A40.250.2.52S	36 (900)	28 (700)	4"	12 (300)	32 (800)	64.6 (1615)	7.2 (180)	4"	7.64 (191)	0.92 (23)	6 x M24
SE.A40.300.2.52S	36 (900)	28 (700)	4"	12 (300)	32 (800)	64.6 (1615)	7.2 (180)	4"	7.64 (191)	0.92 (23)	6 x M24
SE.A40.335.2.52S	36 (900)	28 (700)	4"	12 (300)	32 (800)	64.6 (1615)	7.2 (180)	4"	7.64 (191)	0.92 (23)	6 x M24
SE.A40.390.2.52S	36 (900)	28 (700)	4"	12 (300)	32 (800)	64.6 (1615)	7.2 (180)	4"	7.64 (191)	0.92 (23)	6 x M24

Pump type	X8	X9	X10	X11	X12	X16	XDc3	DN2	XDc2	Dt2	XM1
SE.A40.420.2.52S	36 (900)	28 (700)	4"	12 (300)	32 (800)	64.6 (1615)	7.2 (180)	4"	7.64 (191)	0.92 (23)	6 x M24
SEV.30.A30.200.2.52H	36 (900)	28 (700)	4"	12 (300)	32 (800)	64 (1600)	7.2 (180)	3"	6.72 (168)	1 (25)	6 x M24
SEV.30.A30.230.2.52H	36 (900)	28 (700)	4"	12 (300)	32 (800)	64 (1600)	7.2 (180)	3"	6.72 (168)	1 (25)	6 x M24
SEV.30.A30.250.2.52H	36 (900)	28 (700)	4"	12 (300)	32 (800)	64 (1600)	7.2 (180)	3"	6.72 (168)	1 (25)	6 x M24
SEV.30.A30.300.2.52H	36 (900)	28 (700)	4"	12 (300)	32 (800)	64 (1600)	7.2 (180)	3"	6.72 (168)	1 (25)	6 x M24
SEV.30.A30.335.2.52H	36 (900)	28 (700)	4"	12 (300)	32 (800)	64 (1600)	7.2 (180)	3"	6.72 (168)	1 (25)	6 x M24
SEV.30.A30.390.2.52H	36 (900)	28 (700)	4"	12 (300)	32 (800)	64 (1600)	7.2 (180)	3"	6.72 (168)	1 (25)	6 x M24
SEV.30.A30.420.2.52H	36 (900)	28 (700)	4"	12 (300)	32 (800)	64 (1600)	7.2 (180)	3"	6.72 (168)	1 (25)	6 x M24
SE1.30.A40.200.4.52H	36 (900)	28 (700)	6"	12 (300)	32 (800)	72.48 (1812)	9.6 (240)	4"	9.64 (241)	0.96 (24)	6 x M24
SE.A40.200.4.52H	36 (900)	28 (700)	6"	12 (300)	32 (800)	72.44 (1811)	9.6 (240)	4"	7.2 (180)	0.96 (24)	6 x M24
SE1.35.A40.245.4.52H	36 (900)	28 (700)	6"	12 (300)	32 (800)	72.52 (1813)	9.6 (240)	4"	7.64 (191)	1 (25)	6 x M24
SE.A40.245.4.52H	36 (900)	28 (700)	6"	12 (300)	32 (800)	72.56 (1814)	9.6 (240)	4"	7.2 (180)	1 (25)	6 x M24
SE1.35.A40.270.4.52H	36 (900)	28 (700)	6"	12 (300)	32 (800)	72.52 (1813)	9.6 (240)	4"	7.64 (191)	1 (25)	6 x M24
SE.A40.270.4.52H	36 (900)	28 (700)	6"	12 (300)	32 (800)	72.56 (1814)	9.6 (240)	4"	7.2 (180)	1 (25)	6 x M24
SE1.35.A40.300.4.52H	36 (900)	28 (700)	6"	12 (300)	32 (800)	72.52 (1813)	9.6 (240)	4"	7.64 (191)	1 (25)	6 x M24
SE.A40.300.4.52H	36 (900)	28 (700)	6"	12 (300)	32 (800)	72.56 (1814)	9.6 (240)	4"	7.2 (180)	1 (25)	6 x M24
SE1.35.A40.330.4.52H	36 (900)	28 (700)	6"	12 (300)	32 (800)	72.52 (1813)	9.6 (240)	4"	7.64 (191)	1 (25)	6 x M24
SE.A40.330.4.52H	36 (900)	28 (700)	6"	12 (300)	32 (800)	72.56 (1814)	9.6 (240)	4"	7.2 (180)	1 (25)	6 x M24
SE1.30.A60.200.4.52H	36 (900)	28 (700)	6"	12 (300)	32 (800)	72.36 (1809)	9.6 (240)	6"	9.6 (240)	1.08 (27)	6 x M24
SE.A60.200.4.52H	36 (900)	28 (700)	6"	12 (300)	32 (800)	72.44 (1811)	9.6 (240)	6"	9.6 (240)	1.08 (27)	6 x M24
SE1.35.A60.245.4.52H	36 (900)	28 (700)	6"	12 (300)	32 (800)	72.4 (1810)	9.6 (240)	6"	9.6 (240)	1.08 (27)	6 x M24
SE.A60.245.4.52H	36 (900)	28 (700)	6"	12 (300)	32 (800)	72.56 (1814)	9.6 (240)	6"	9.6 (240)	1.08 (27)	6 x M24
SE1.35.A60.270.4.52H	36 (900)	28 (700)	6"	12 (300)	32 (800)	72.4 (1810)	9.6 (240)	6"	9.6 (240)	1.08 (27)	6 x M24
SE.A60.270.4.52H	36 (900)	28 (700)	6"	12 (300)	32 (800)	72.56 (1814)	9.6 (240)	6"	9.6 (240)	1.08 (27)	6 x M24
SE1.35.A60.300.4.52H	36 (900)	28 (700)	6"	12 (300)	32 (800)	72.4 (1810)	9.6 (240)	6"	9.6 (240)	1.08 (27)	6 x M24

Pump type	X8	X9	X10	X11	X12	X16	XDc3	DN2	XDc2	Dt2	XM1
SE.A60.300.4.52H	36 (900)	28 (700)	6"	12 (300)	32 (800)	72.56 (1814)	9.6 (240)	6"	9.6 (240)	1.08 (27)	6 x M24
SE1.35.A60.330.4.52H	36 (900)	28 (700)	6"	12 (300)	32 (800)	72.4 (1810)	9.6 (240)	6"	9.6 (240)	1.08 (27)	6 x M24
SE.A60.330.4.52H	36 (900)	28 (700)	6"	12 (300)	32 (800)	72.56 (1814)	9.6 (240)	6"	9.6 (240)	1.08 (27)	6 x M24
SE1.40.A80.200.4.52M	36 (900)	28 (700)	8"	12 (300)	32 (800)	76.28 (1907)	11.84 (296)	8"	11.88 (297)	1.2 (30)	6 x M24
SE1.45.A80.245.4.52M	36 (900)	28 (700)	8"	12 (300)	32 (800)	76.68 (1917)	11.84 (296)	8"	11.88 (297)	1.2 (30)	6 x M24
SE1.45.A80.270.4.52M	36 (900)	28 (700)	8"	12 (300)	32 (800)	76.68 (1917)	11.84 (296)	8"	11.88 (297)	1.2 (30)	6 x M24
SE1.45.A80.300.4.52M	36 (900)	28 (700)	8"	12 (300)	32 (800)	76.68 (1917)	11.84 (296)	8"	11.88 (297)	1.2 (30)	6 x M24
SE1.45.A80.330.4.52M	36 (900)	28 (700)	8"	12 (300)	32 (800)	76.68 (1917)	11.84 (296)	8"	11.88 (297)	1.2 (30)	6 x M24
SE2.45.A100.200.4.52L	36 (900)	28 (700)	10"	12 (300)	32 (800)	78.12 (1953)	14 (350)	10"	14 (350)	1.28 (32)	6 x M24
SE2.45.A100.245.4.52L	36 (900)	28 (700)	10"	12 (300)	32 (800)	78.12 (1953)	14 (350)	10"	14 (350)	1.28 (32)	6 x M24
SE2.45.A100.270.4.52L	36 (900)	28 (700)	10"	12 (300)	32 (800)	78.12 (1953)	14 (350)	10"	14 (350)	1.28 (32)	6 x M24
SE2.45.A100.300.4.52L	36 (900)	28 (700)	10"	12 (300)	32 (800)	78.12 (1953)	14 (350)	10"	14 (350)	1.28 (32)	6 x M24
SE2.45.A100.330.4.52L	36 (900)	28 (700)	10"	12 (300)	32 (800)	78.12 (1953)	14 (350)	10"	14 (350)	1.28 (32)	6 x M24
SE2.50.A120.215.6.52E	36 (900)	28 (700)	12"	12 (300)	32 (800)	83.32 (2083)	16 (400)	12"	17.28 (432)	1.28 (32)	6 x M24
SE2.50.A120.255.6.52E	36 (900)	28 (700)	12"	12 (300)	32 (800)	83.32 (2083)	16 (400)	12"	17.28 (432)	1.28 (32)	6 x M24

Dry, horizontal installation

Installation on horizontal base stand

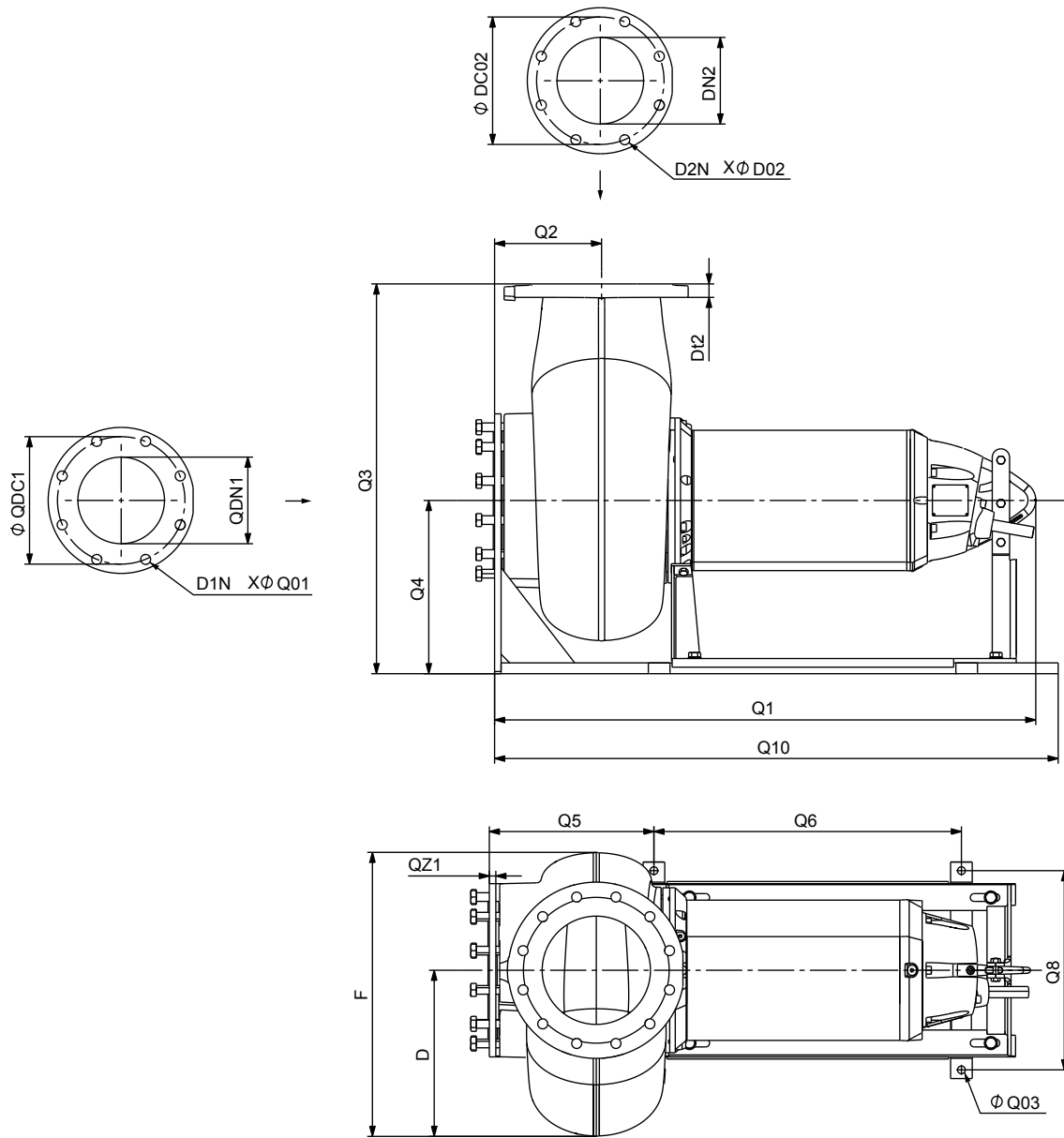

TM052580

Dry, horizontal dimensions

SE/SE1/SE2/SEV [in (mm)] (part 1)

Pump type SE1/SE2/SEV	D	F	Q1	Q2	Q3	Q4	Q5	Q6	Q8	Q10
SE1.30.A40.175.2.52S	7.6 (193)	15.2 (386)	45.4 (1154)	5.8 (148)	27 (685)	15.7 (400)	15 (380)	28 (710)	18.1 (460)	50.2 (1275)
SE.A40.175.2.52S	7.5 (191)	15 (382)	45.6 (1158)	6.5 (166)	27 (685)	15.7 (400)	15 (380)	28 (710)	18.1 (460)	50.2 (1275)
SE1.30.A40.200.2.52S	7.6 (193)	15.2 (386)	45.4 (1154)	5.8 (148)	27 (685)	15.7 (400)	15 (380)	28 (710)	18.1 (460)	50.2 (1275)

Pump type SE1/SE2/SEV	D	F	Q1	Q2	Q3	Q4	Q5	Q6	Q8	Q10
SE.A40.200.2.52S	7.5 (191)	15 (382)	45.6 (1158)	6.5 (166)	27 (685)	15.7 (400)	15 (380)	28 (710)	18.1 (460)	50.2 (1275)
SE1.30.A40.230.2.52S	7.6 (193)	15.2 (386)	45.4 (1154)	5.8 (148)	27 (685)	15.7 (400)	15 (380)	28 (710)	18.1 (460)	50.2 (1275)
SE.A40.230.2.52S	7.5 (191)	15 (382)	45.6 (1158)	6.5 (166)	27 (685)	15.7 (400)	15 (380)	28 (710)	18.1 (460)	50.2 (1275)
SE1.30.A40.250.2.52S	7.6 (193)	15.2 (386)	45.4 (1154)	5.8 (148)	27 (685)	15.7 (400)	15 (380)	28 (710)	18.1 (460)	50.2 (1275)
SE.A40.250.2.52S	7.5 (191)	15 (382)	45.6 (1158)	6.5 (166)	27 (685)	15.7 (400)	15 (380)	28 (710)	18.1 (460)	50.2 (1275)
SE1.30.A40.120.4.52H	9.3 (236)	16.8 (427)	46.3 (1177)	7.8 (198)	30 (780)	15.7 (400)	15 (380)	28 (710)	18.1 (460)	50.2 (1275)
SE.A40.120.4.52H	9.3 (236)	16.8 (427)	46.3 (1176)	7.8 (198)	30 (780)	15.7 (400)	15 (380)	28 (710)	18.1 (460)	50.2 (1275)
SE1.30.A40.150.4.52H	9.3 (236)	16.8 (427)	46.3 (1177)	7.8 (198)	30 (780)	15.7 (400)	15 (380)	28 (710)	18.1 (460)	50.2 (1275)
SE.A40.150.4.52H	9.3 (236)	16.8 (427)	46.3 (1176)	7.8 (198)	30 (780)	15.7 (400)	15 (380)	28 (710)	18.1 (460)	50.2 (1275)
SE1.30.A40.175.4.52H	9.3 (236)	16.8 (427)	46.3 (1177)	7.8 (198)	30 (780)	15.7 (400)	15 (380)	28 (710)	18.1 (460)	50.2 (1275)
SE.A40.175.4.52H	9.3 (236)	16.8 (427)	46.3 (1176)	7.8 (198)	30 (780)	15.7 (400)	15 (380)	28 (710)	18.1 (460)	50.2 (1275)
SE1.30.A40.200.4.52H	9.3 (236)	16.8 (427)	46.3 (1177)	7.8 (198)	30 (780)	15.7 (400)	15 (380)	28 (710)	18.1 (460)	50.2 (1275)
SE.A40.200.4.52H	9.3 (236)	16.8 (427)	46.3 (1176)	7.8 (198)	30 (780)	15.7 (400)	15 (380)	28 (710)	18.1 (460)	50.2 (1275)
SE1.35.A40.245.4.52H	10 (255)	18.1 (460)	46.4 (1178)	7.8 (202)	30 (780)	15.7 (400)	15 (380)	28 (710)	18.1 (460)	50.2 (1275)
SE.A40.245.4.52H	10 (255)	18.2 (462)	46.4 (1179)	7.8 (202)	30 (780)	15.7 (400)	15 (380)	28 (710)	18.1 (460)	50.2 (1275)
SE1.35.A40.270.4.52H	10 (255)	18.1 (460)	46.4 (1178)	7.8 (202)	30 (780)	15.7 (400)	15 (380)	28 (710)	18.1 (460)	50.2 (1275)
SE.A40.270.4.52H	10 (255)	18.2 (462)	46.4 (1179)	7.8 (202)	30 (780)	15.7 (400)	15 (380)	28 (710)	18.1 (460)	50.2 (1275)
SE1.35.A40.300.4.52H	10 (255)	18.1 (460)	46.4 (1178)	7.8 (202)	30 (780)	15.7 (400)	15 (380)	28 (710)	18.1 (460)	50.2 (1275)
SE.A40.300.4.52H	10 (255)	18.2 (462)	46.4 (1179)	7.8 (202)	30 (780)	15.7 (400)	15 (380)	28 (710)	18.1 (460)	50.2 (1275)
SE1.35.A40.330.4.52H	10 (255)	18.1 (460)	46.4 (1178)	7.8 (202)	30 (780)	15.7 (400)	15 (380)	28 (710)	18.1 (460)	50.2 (1275)
SE.A40.330.4.52H	10 (255)	18.2 (462)	46.4 (1179)	7.8 (202)	30 (780)	15.7 (400)	15 (380)	28 (710)	18.1 (460)	50.2 (1275)
SE1.30.A60.120.4.52H	11.2 (284)	16.7 (424)	46.3 (1177)	7.4 (188)	29.5 (750)	15.7 (400)	15 (380)	28 (710)	18.1 (460)	50.2 (1275)
SE.A60.120.4.52H	9.2 (233)	16.7 (424)	46.3 (1176)	7.4 (188)	29.5 (750)	15.7 (400)	15 (380)	28 (710)	18.1 (460)	50.2 (1275)
SE1.30.A60.150.4.52H	11.2 (284)	16.7 (424)	46.3 (1177)	7.4 (188)	29.5 (750)	15.7 (400)	15 (380)	28 (710)	18.1 (460)	50.2 (1275)
SE.A60.150.4.52H	9.2 (233)	16.7 (424)	46.3 (1176)	7.4 (188)	29.5 (750)	15.7 (400)	15 (380)	28 (710)	18.1 (460)	50.2 (1275)
SE1.30.A60.175.4.52H	11.2 (284)	16.7 (424)	46.3 (1177)	7.4 (188)	29.5 (750)	15.7 (400)	15 (380)	28 (710)	18.1 (460)	50.2 (1275)
SE.A60.175.4.52H	9.2 (233)	16.7 (424)	46.3 (1176)	7.4 (188)	29.5 (750)	15.7 (400)	15 (380)	28 (710)	18.1 (460)	50.2 (1275)
SE1.30.A60.200.4.52H	11.2 (284)	16.7 (424)	46.3 (1177)	7.4 (188)	29.5 (750)	15.7 (400)	15 (380)	28 (710)	18.1 (460)	50.2 (1275)

Pump type SE1/SE2/SEV	D	F	Q1	Q2	Q3	Q4	Q5	Q6	Q8	Q10
SE.A60.200.4.52H	9.2 (233)	16.7 (424)	46.3 (1176)	7.4 (188)	29.5 (750)	15.7 (400)	15 (380)	28 (710)	18.1 (460)	50.2 (1275)
SE1.35.A60.245.4.52H	9.9 (251)	17.9 (454)	46.3 (1177)	7.5 (191)	30 (780)	15.7 (400)	15 (380)	28 (710)	18.1 (460)	50.2 (1275)
SE.A60.245.4.52H	9.9 (251)	17.9 (454)	46.4 (1179)	7.5 (191)	30 (780)	15.7 (400)	15 (380)	28 (710)	18.1 (460)	50.2 (1275)
SE1.35.A60.270.4.52H	10.5 (251)	17.9 (454)	46.3 (1177)	7.5 (191)	30 (780)	15.7 (400)	15 (380)	28 (710)	18.1 (460)	50.2 (1275)
SE.A60.270.4.52H	9.9 (251)	17.9 (454)	46.4 (1179)	7.5 (191)	30 (780)	15.7 (400)	15 (380)	28 (710)	18.1 (460)	50.2 (1275)
SE1.35.A60.300.4.52H	9.9 (251)	17.9 (454)	46.3 (1177)	7.5 (191)	30 (780)	15.7 (400)	15 (380)	28 (710)	18.1 (460)	50.2 (1275)
SE.A60.300.4.52H	9.9 (251)	17.9 (454)	46.4 (1179)	7.5 (191)	30 (780)	15.7 (400)	15 (380)	28 (710)	18.1 (460)	50.2 (1275)
SE1.35.A60.330.4.52H	9.9 (251)	17.9 (454)	46.3 (1177)	7.5 (191)	30 (780)	15.7 (400)	15 (380)	28 (710)	18.1 (460)	50.2 (1275)
SE.A60.330.4.52H	9.9 (251)	17.9 (454)	46.4 (1179)	7.5 (191)	30 (780)	15.7 (400)	15 (380)	28 (710)	18.1 (460)	50.2 (1275)
SE1.40.A80.120.4.52M	10.5 (267)	18.5 (470)	47 (1196)	7.2 (182)	35.4 (900)	15.7 (400)	15 (380)	28 (710)	18.1 (460)	50.2 (1275)
SE1.40.A80.150.4.52M	10.5 (267)	18.5 (470)	47 (1196)	7.2 (182)	35.4 (900)	15.7 (400)	15 (380)	28 (710)	18.1 (460)	50.2 (1275)
SE1.40.A80.175.4.52M	10.5 (267)	18.5 (470)	47 (1196)	7.2 (182)	35.4 (900)	15.7 (400)	15 (380)	28 (710)	18.1 (460)	50.2 (1275)
SE1.40.A80.200.4.52M	10.5 (267)	18.5 (470)	47 (1196)	7.2 (182)	35.4 (900)	15.7 (400)	15 (380)	28 (710)	18.1 (460)	50.2 (1275)
SE1.45.A80.245.4.52M	12 (278)	19.7 (500)	47.5 (1206)	8 (205)	35.4 (900)	15.7 (400)	15 (380)	28 (710)	18.1 (460)	50.2 (1275)
SE1.45.A80.270.4.52M	12 (278)	19.7 (500)	47.5 (1206)	8 (205)	35.4 (900)	15.7 (400)	15 (380)	28 (710)	18.1 (460)	50.2 (1275)
SE1.45.A80.300.4.52M	12 (278)	19.7 (500)	47.5 (1206)	8 (205)	35.4 (900)	15.7 (400)	15 (380)	28 (710)	18.1 (460)	50.2 (1275)
SE1.45.A80.330.4.52M	12 (278)	19.7 (500)	47.5 (1206)	8 (205)	35.4 (900)	15.7 (400)	15 (380)	28 (710)	18.1 (460)	50.2 (1275)
SE2.45.A100.150.4.52L	15.5 (394)	26.8 (680)	48 (1220)	8.5 (216)	35.4 (900)	15.7 (400)	15 (380)	28 (710)	18.1 (460)	50.2 (1275)
SE2.45.A100.175.4.52L	15.5 (394)	26.8 (680)	48 (1220)	8.5 (216)	35.4 (900)	15.7 (400)	15 (380)	28 (710)	18.1 (460)	50.2 (1275)
SE2.45.A100.200.4.52L	15.5 (394)	26.8 (680)	48 (1220)	8.5 (216)	35.4 (900)	15.7 (400)	15 (380)	28 (710)	18.1 (460)	50.2 (1275)
SE2.45.A100.245.4.52L	15.5 (394)	26.8 (680)	48 (1220)	8.5 (216)	35.4 (900)	15.7 (400)	15 (380)	28 (710)	18.1 (460)	50.2 (1275)
SE2.45.A100.270.4.52L	15.5 (394)	26.8 (680)	48 (1220)	8.5 (216)	35.4 (900)	15.7 (400)	15 (380)	28 (710)	18.1 (460)	50.2 (1275)
SE2.45.A100.300.4.52L	15.5 (394)	26.8 (680)	48 (1220)	8.5 (216)	35.4 (900)	15.7 (400)	15 (380)	28 (710)	18.1 (460)	50.2 (1275)
SE2.45.A100.330.4.52L	15.5 (394)	26.8 (680)	48 (1220)	8.5 (216)	35.4 (900)	15.7 (400)	15 (380)	28 (710)	18.1 (460)	50.2 (1275)
SE2.45.A100.110.6.52E	15.5 (394)	26.8 (680)	48 (1220)	8.5 (216)	35.4 (900)	15.7 (400)	15 (380)	28 (710)	18.1 (460)	50.2 (1275)
SE2.45.A100.135.6.52E	15.5 (394)	26.8 (680)	48 (1220)	8.5 (216)	35.4 (900)	15.7 (400)	15 (380)	28 (710)	18.1 (460)	50.2 (1275)
SE2.45.A100.160.6.52E	15.5 (394)	26.8 (680)	48 (1220)	8.5 (216)	35.4 (900)	15.7 (400)	15 (380)	28 (710)	18.1 (460)	50.2 (1275)
SE2.50.A120.190.6.52E	16 (407)	27.2 (691)	50 (1272)	9.8 (248)	39.3 (1000)	15.7 (400)	15 (380)	28 (710)	18.1 (460)	50.2 (1275)

Pump type SE1/SE2/SEV	D	F	Q1	Q2	Q3	Q4	Q5	Q6	Q8	Q10
SE2.50.A120.215.6.52E	16 (407)	27.2 (691)	50 (1272)	9.8 (248)	39.3 (1000)	15.7 (400)	15 (380)	28 (710)	18.1 (460)	50.2 (1275)
SE2.50.A120.255.6.52E	16 (407)	27.2 (691)	50 (1272)	9.8 (248)	39.3 (1000)	15.7 (400)	15 (380)	28 (710)	18.1 (460)	50.2 (1275)
SEV.30.A30.175.2.52H	7.6 (192)	15.2 (385)	45 (1142)	6.6 (168)	28.7 (730)	15.7 (400)	15 (380)	28 (710)	18.1 (460)	50.2 (1275)
SEV.30.A30.230.2.52H	7.6 (192)	15.2 (385)	45 (1142)	6.6 (168)	28.7 (730)	15.7 (400)	15 (380)	28 (710)	18.1 (460)	50.2 (1275)
SEV.30.A30.250.2.52H	7.6 (192)	15.2 (385)	45 (1142)	6.6 (168)	28.7 (730)	15.7 (400)	15 (380)	28 (710)	18.1 (460)	50.2 (1275)
SEV.30.A30.300.2.52H	7.6 (192)	15.2 (385)	45 (1142)	6.6 (168)	28.7 (730)	15.7 (400)	15 (380)	28 (710)	18.1 (460)	50.2 (1275)
SEV.30.A30.335.2.52H	7.6 (192)	15.2 (385)	45 (1142)	6.6 (168)	28.7 (730)	15.7 (400)	15 (380)	28 (710)	18.1 (460)	50.2 (1275)
SEV.30.A30.390.2.52H	7.6 (192)	15.2 (385)	45 (1142)	6.6 (168)	28.7 (730)	15.7 (400)	15 (380)	28 (710)	18.1 (460)	50.2 (1275)
SEV.30.A30.420.2.52H	7.6 (192)	15.2 (385)	45 (1142)	6.6 (168)	28.7 (730)	15.7 (400)	15 (380)	28 (710)	18.1 (460)	50.2 (1275)

SE/SE1/SE2/SEV [in (mm)] (part 2)

Pump type SE1/SE2/SEV	QZ1	QDc1	DN1	Q01	D1N	D02	D2N	Dc02	DN2	Dt2	Q03
SE1.30.A40.175.2.52S	0.7 (18)	7.5 (191)	4"	M16	8	0.7 (19)	8	7.5 (191)	4"	0.9 (23)	0.7 (18)
SE.A40.175.2.52S	0.7 (18)	7.5 (191)	4"	M16	8	0.7 (19)	8	7.5 (191)	4"	1 (25)	0.7 (18)
SE1.30.A40.200.2.52S	0.7 (18)	7.5 (191)	4"	M16	8	0.7 (19)	8	7.5 (191)	4"	0.9 (23)	0.7 (18)
SE.A40.200.2.52S	0.7 (18)	7.5 (191)	4"	M16	8	0.7 (19)	8	7.5 (191)	4"	1 (25)	0.7 (18)
SE1.30.A40.230.2.52S	0.7 (18)	7.5 (191)	4"	M16	8	0.7 (19)	8	7.5 (191)	4"	0.9 (23)	0.7 (18)
SE.A40.230.2.52S	0.7 (18)	7.5 (191)	4"	M16	8	0.7 (19)	8	7.5 (191)	4"	1 (25)	0.7 (18)
SE1.30.A40.250.2.52S	0.7 (18)	7.5 (191)	4"	M16	8	0.7 (19)	8	7.5 (191)	4"	0.9 (23)	0.7 (18)
SE.A40.250.2.52S	0.7 (18)	7.5 (191)	4"	M16	8	0.7 (19)	8	7.5 (191)	4"	1 (25)	0.7 (18)
SE1.30.A40.120.4.52H	0.7 (18)	9.4 (240)	6"	M20	8	0.7 (19)	8	7.5 (191)	4"	0.9 (24)	0.7 (18)
SE.A40.120.4.52H	0.7 (18)	9.5 (241)	6"	M20	8	0.7 (19)	8	7 (180)	4"	1 (25)	0.7 (18)
SE1.30.A40.150.4.52H	0.7 (18)	9.4 (240)	6"	M20	8	0.7 (19)	8	7.5 (191)	4"	0.9 (24)	0.7 (18)
SE.A40.150.4.52H	0.7 (18)	9.5 (241)	6"	M20	8	0.7 (19)	8	7 (180)	4"	1 (25)	0.7 (18)
SE1.30.A40.175.4.52H	0.7 (18)	9.4 (240)	6"	M20	8	0.7 (19)	8	7.5 (191)	4"	0.9 (24)	0.7 (18)
SE.A40.175.4.52H	0.7 (18)	9.5 (241)	6"	M20	8	0.7 (19)	8	7 (180)	4"	1 (25)	0.7 (18)
SE1.30.A40.200.4.52H	0.7 (18)	9.4 (240)	6"	M20	8	0.7 (19)	8	7.5 (191)	4"	0.9 (24)	0.7 (18)
SE.A40.200.4.52H	0.7 (18)	9.5 (241)	6"	M20	8	0.7 (19)	8	7 (180)	4"	1 (25)	0.7 (18)
SE1.35.A40.245.4.52H	0.7 (18)	9.4 (240)	6"	M20	8	0.7 (19)	8	7.5 (191)	4"	0.9 (24)	0.7 (18)

Pump type SE1/SE2/SEV	QZ1	QDc1	DN1	Q01	D1N	D02	D2N	Dc02	DN2	Dt2	Q03
SE.A40.245.4.52H	0.7 (18)	9.5 (241)	6"	M20	8	0.7 (19)	8	7 (180)	4"	1 (25)	0.7 (18)
SE1.35.A40.270.4.52H	0.7 (18)	9.4 (240)	6"	M20	8	0.7 (19)	8	7.5 (191)	4"	0.9 (24)	0.7 (18)
SE.A40.270.4.52H	0.7 (18)	9.5 (241)	6"	M20	8	0.7 (19)	8	7 (180)	4"	1 (25)	0.7 (18)
SE1.35.A40.300.4.52H	0.7 (18)	9.4 (240)	6"	M20	8	0.7 (19)	8	7.5 (191)	4"	0.9 (24)	0.7 (18)
SE.A40.300.4.52H	0.7 (18)	9.5 (241)	6"	M20	8	0.7 (19)	8	7 (180)	4"	1 (25)	0.7 (18)
SE1.35.A40.330.4.52H	0.7 (18)	9.4 (240)	6"	M20	8	0.7 (19)	8	7.5 (191)	4"	0.9 (24)	0.7 (18)
SE.A40.330.4.52H	0.7 (18)	9.5 (241)	6"	M20	8	0.7 (19)	8	7 (180)	4"	1 (25)	0.7 (18)
SE1.30.A60.120.4.52H	0.7 (18)	9.4 (240)	6"	M20	8	0.9 (23)	8	11.7 (297)	6"	1.2 (28)	0.7 (18)
SE.A60.120.4.52H	0.7 (18)	9.5 (241)	6"	M20	8	0.9 (23)	8	9.5 (241)	6"	1.1 (27)	0.7 (18)
SE1.30.A60.150.4.52H	0.7 (18)	9.4 (240)	6"	M20	8	0.9 (23)	8	11.7 (297)	6"	1.2 (28)	0.7 (18)
SE.A60.150.4.52H	0.7 (18)	9.5 (241)	6"	M20	8	0.9 (23)	8	9.5 (241)	6"	1.1 (27)	0.7 (18)
SE1.30.A60.175.4.52H	0.7 (18)	9.4 (240)	6"	M20	8	0.9 (23)	8	11.7 (297)	6"	1.2 (28)	0.7 (18)
SE.A60.175.4.52H	0.7 (18)	9.5 (241)	6"	M20	8	0.9 (23)	8	9.5 (241)	6"	1.1 (27)	0.7 (18)
SE1.30.A60.200.4.52H	0.7 (18)	9.4 (240)	6"	M20	8	0.9 (23)	8	11.7 (297)	6"	1.2 (28)	0.7 (18)
SE.A60.200.4.52H	0.7 (18)	9.5 (241)	6"	M20	8	0.9 (23)	8	9.5 (241)	6"	1.1 (27)	0.7 (18)
SE1.35.A60.245.4.52H	0.7 (18)	9.4 (240)	6"	M20	8	0.9 (23)	8	9.4 (240)	6"	1.1 (27)	0.7 (18)
SE.A60.245.4.52H	0.7 (18)	9.5 (241)	6"	M20	8	0.9 (23)	8	9.5 (241)	6"	1.1 (27)	0.7 (18)
SE1.35.A60.270.4.52H	0.7 (18)	9.4 (240)	6"	M20	8	0.9 (23)	8	9.4 (240)	6"	1.1 (27)	0.7 (18)
SE.A60.270.4.52H	0.7 (18)	9.5 (241)	6"	M20	8	0.9 (23)	8	9.5 (241)	6"	1.1 (27)	0.7 (18)
SE1.35.A60.300.4.52H	0.7 (18)	9.4 (240)	6"	M20	8	0.9 (23)	8	9.4 (240)	6"	1.1 (27)	0.7 (18)
SE.A60.300.4.52H	0.7 (18)	9.5 (241)	6"	M20	8	0.9 (23)	8	9.5 (241)	6"	1.1 (27)	0.7 (18)
SE1.35.A60.330.4.52H	0.7 (18)	9.4 (240)	6"	M20	8	0.9 (23)	8	9.4 (240)	6"	1.1 (27)	0.7 (18)
SE.A60.330.4.52H	0.7 (18)	9.5 (241)	6"	M20	8	0.9 (23)	8	9.5 (241)	6"	1.1 (27)	0.7 (18)
SE1.40.A80.120.4.52M	0.7 (18)	11.7 (297)	8"	M20	8	0.9 (23)	8	9.4 (240)	8"	1.2 (30)	0.7 (18)
SE1.40.A80.150.4.52M	0.7 (18)	11.7 (297)	8"	M20	8	0.9 (23)	8	9.4 (240)	8"	1.2 (30)	0.7 (18)
SE1.40.A80.175.4.52M	0.7 (18)	11.7 (297)	8"	M20	8	0.9 (23)	8	9.4 (240)	8"	1.2 (30)	0.7 (18)
SE1.40.A80.200.4.52M	0.7 (18)	11.7 (297)	8"	M20	8	0.9 (23)	8	9.4 (240)	8"	1.2 (30)	0.7 (18)
SE1.45.A80.245.4.52M	0.7 (18)	11.6 (295)	8"	M20	8	0.9 (23)	8	11.6 (295)	8"	1.2 (30)	0.7 (18)

Pump type SE1/SE2/SEV	QZ1	QDc1	DN1	Q01	D1N	D02	D2N	Dc02	DN2	Dt2	Q03
SE1.45.A80.270.4.52M	0.7 (18)	11.6 (295)	8"	M20	8	0.9 (23)	8	11.6 (295)	8"	1.2 (30)	0.7 (18)
SE1.45.A80.300.4.52M	0.7 (18)	11.6 (295)	8"	M20	8	0.9 (23)	8	11.6 (295)	8"	1.2 (30)	0.7 (18)
SE1.45.A80.330.4.52M	0.7 (18)	11.6 (295)	8"	M20	8	0.9 (23)	8	11.6 (295)	8"	1.2 (30)	0.7 (18)
SE2.45.A100.150.4.52L	0.7 (18)	14.3 (362)	10"	M20	12	0.9 (23)	12	14.3 (362)	10"	1.3 (32)	0.7 (18)
SE2.45.A100.175.4.52L	0.7 (18)	14.3 (362)	10"	M20	12	0.9 (23)	12	14.3 (362)	10"	1.3 (32)	0.7 (18)
SE2.45.A100.200.4.52L	0.7 (18)	14.3 (362)	10"	M20	12	0.9 (23)	12	14.3 (362)	10"	1.3 (32)	0.7 (18)
SE2.45.A100.245.4.52L	0.7 (18)	14.3 (362)	10"	M20	12	0.9 (23)	12	14.3 (362)	10"	1.3 (32)	0.7 (18)
SE2.45.A100.270.4.52L	0.7 (18)	14.3 (362)	10"	M20	12	0.9 (23)	12	14.3 (362)	10"	1.3 (32)	0.7 (18)
SE2.45.A100.300.4.52L	0.7 (18)	14.3 (362)	10"	M20	12	0.9 (23)	12	14.3 (362)	10"	1.3 (32)	0.7 (18)
SE2.45.A100.330.4.52L	0.7 (18)	14.3 (362)	10"	M20	12	0.9 (23)	12	14.3 (362)	10"	1.3 (32)	0.7 (18)
SE2.45.A100.110.6.52E	0.7 (18)	14.3 (362)	10"	M20	12	0.9 (23)	12	14.3 (362)	10"	1.3 (32)	0.7 (18)
SE2.45.A100.135.6.52E	0.7 (18)	14.3 (362)	10"	M20	12	0.9 (23)	12	14.3 (362)	10"	1.3 (32)	0.7 (18)
SE2.45.A100.160.6.52E	0.7 (18)	14.3 (362)	10"	M20	12	0.9 (23)	12	14.3 (362)	10"	1.3 (32)	0.7 (18)
SE2.50.A120.190.6.52E	0.7 (18)	17 (432)	12"	M20	12	1 (25)	12	17 (432)	12"	1.3 (32)	0.7 (18)
SE2.50.A120.215.6.52E	0.7 (18)	17 (432)	12"	M20	12	1 (25)	12	17 (432)	12"	1.3 (32)	0.7 (18)
SE2.50.A120.255.6.52E	0.7 (18)	17 (432)	12"	M20	12	1 (25)	12	17 (432)	12"	1.3 (32)	0.7 (18)
SEV.30.A30.175.2.52H	0.7 (18)	7.1 (180)	4"	M16	8	0.7 (18)	8	6.3 (160)	3"	1 (25)	0.7 (18)
SEV.30.A30.230.2.52H	0.7 (18)	7.1 (180)	4"	M16	8	0.7 (18)	8	6.3 (160)	3"	1 (25)	0.7 (18)
SEV.30.A30.250.2.52H	0.7 (18)	7.1 (180)	4"	M16	8	0.7 (18)	8	6.3 (160)	3"	1 (25)	0.7 (18)
SEV.30.A30.300.2.52H	0.7 (18)	7.1 (180)	4"	M16	8	0.7 (18)	8	6.3 (160)	3"	1 (25)	0.7 (18)
SEV.30.A30.335.2.52H	0.7 (18)	7.1 (180)	4"	M16	8	0.7 (18)	8	6.3 (160)	3"	1 (25)	0.7 (18)
SEV.30.A30.390.2.52H	0.7 (18)	7.1 (180)	4"	M16	8	0.7 (18)	8	6.3 (160)	3"	1 (25)	0.7 (18)
SEV.30.A30.420.2.52H	0.7 (18)	7.1 (180)	4"	M16	8	0.7 (18)	8	6.3 (160)	3"	1 (25)	0.7 (18)

11. Grundfos Product Center

Online search and sizing tool to help you make the right choice.

From the international view, you can select your specific country to view the product range available to you.

International view: <https://product-selection.grundfos.com>

All the information you need in one place

Performance curves, technical specifications, pictures, dimensional drawings, motor curves, wiring diagrams, spare parts, service kits, 3D drawings, documents, system parts. The Product Center displays any recent and saved items - including complete projects - right on the main page.

Downloads

On the product pages, you can download installation and operating instructions, data booklets, service instructions, etc., in PDF format.

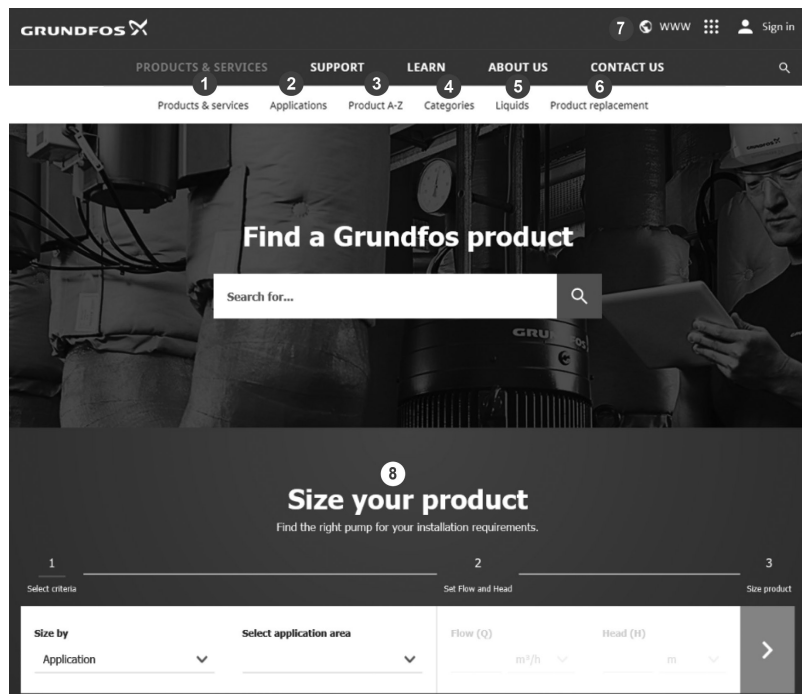

When you select your country, you will see the menus below. Note that some menus may not be available depending on the country.

Example: <https://product-selection.grundfos.com/uk>

Pos.	Description
1	Products & services enables you to find products and documents by typing a product number or name into the search field.
2	Applications enables you to choose an application to see how Grundfos can help you design and optimise your system.
3	Products A-Z enables you to look through a list of all the Grundfos products.
4	Categories enables you to look for a product category.
5	Liquids enables you to find pumps designed for aggressive, flammable or other special liquids.
6	Product replacement enables you to find a suitable replacement.
7	WWW enables you to select the country, which changes the language, the available product range and the structure of the website.
8	Sizing enables you to size a product based on your application and operating conditions.

Grundfos GO

Mobile solution for professionals on the GO!

Grundfos GO is the mobile tool box for professional users on the go. It is the most comprehensive platform for mobile pump control and pump selection including sizing, replacement and documentation. It offers intuitive, handheld assistance and access to Grundfos online tools, and it saves valuable time for reporting and data collection.



GET IT ON
Google play

Available on the
App Store

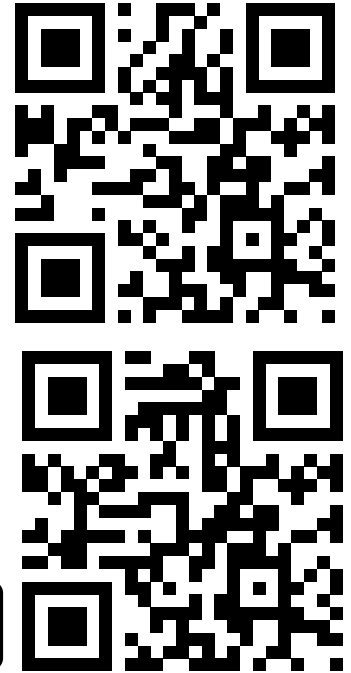

Argentina

Bombas GRUNDFOS de Argentina S.A.
Ruta Panamericana km. 37.500 Industlin
1619 - Garin Pcia. de B.A.
Tel.: +54-3327 414 444
Fax: +54-3327 45 3190

Australia

GRUNDFOS Pumps Pty. Ltd.
P.O. Box 2040
Regency Park
South Australia 5942
Tel.: +61-8-8461-4611
Fax: +61-8-8340-0155

Austria

GRUNDFOS Pumpen Vertrieb Ges.m.b.H.
Grundfosstraße 2
A-5082 Grödig/Salzburg
Tel.: +43-6246-883-0
Fax: +43-6246-883-03

Belgium

N.V. GRUNDFOS Bellux S.A.
Boomssesteenweg 81-83
B-2630 Aartselaar
Tel.: +32-3-870 7300
Fax: +32-3-870 7301

Bosnia and Herzegovina

GRUNDFOS Sarajevo
Zmaj od Bosne 7-7A
BiH-71000 Sarajevo
Tel.: +387 33 592 480
Fax: +387 33 590 465
www.ba.grundfos.com
E-mail: grundfos@bih.net.ba

Brazil

BOMBAS GRUNDFOS DO BRASIL
Av. Humberto de Alencar Castelo Branco,
630
CEP 09850 - 300
São Bernardo do Campo - SP
Tel.: +55-11 4393 5533
Fax: +55-11 4343 5015

Bulgaria

Grundfos Bulgaria EOOD
Slatina District
Iztocna Tangenta street no. 100
BG - 1592 Sofia
Tel.: +359 2 49 22 200
Fax: +359 2 49 22 201
E-mail: bulgaria@grundfos.bg

Canada

GRUNDFOS Canada inc.
2941 Brighton Road
Oakville, Ontario
L6H 6C9
Tel.: +1-905 829 9533
Fax: +1-905 829 9512

China

GRUNDFOS Pumps (Shanghai) Co. Ltd.
10F The Hub, No. 33 Suhong Road
Minhang District
Shanghai 201106 PRC
Tel.: +86 21 612 252 22
Fax: +86 21 612 253 33

Colombia

GRUNDFOS Colombia S.A.S.
Km 1.5 vía Siberia-Cota Conj. Potrero
Chico,
Parque Empresarial Arcos de Cota Bod. 1A.
Cota, Cundinamarca
Tel.: +57(1)-2913444
Fax: +57(1)-8764586

Croatia

GRUNDFOS CROATIA d.o.o.
Buzinski prilaz 38, Buzin
HR-10010 Zagreb
Tel.: +385 1 6595 400
Fax: +385 1 6595 499
www.hr.grundfos.com

Czech Republic

GRUNDFOS Sales Czechia and Slovakia
s.r.o.
Čajkovského 21
779 00 Olomouc
Tel.: +420-585-716 111

Denmark

GRUNDFOS DK A/S
Martin Bachs Vej 3
DK-8850 Bjerringbro
Tel.: +45-87 50 50 50
Fax: +45-87 50 51 51
E-mail: info_GDK@grundfos.com
www.grundfos.com/DK

Estonia

GRUNDFOS Pumps Eesti OÜ
Peterburi tee 92G
11415 Tallinn
Tel.: + 372 606 1690
Fax: + 372 606 1691

Finland

OY GRUNDFOS Pumput AB
Trukkikuja 1
FI-01360 Vantaa
Tel.: +358-(0) 207 889 500

France

Pompes GRUNDFOS Distribution S.A.
Parc d'Activités de Chesnes
57, rue de Malacombe
F-38290 St. Quentin Fallavier (Lyon)
Tel.: +33-4 74 82 15 15
Fax: +33-4 74 94 10 51

Germany

GRUNDFOS GMBH
Schlüterstr. 33
40699 Erkrath
Tel.: +49-(0) 211 929 69-0
Fax: +49-(0) 211 929 69-3799
E-mail: infoservice@grundfos.de
Service in Deutschland:
kundendienst@grundfos.de

Greece

GRUNDFOS Hellas A.E.B.E.
20th km. Athinon-Markopoulou Av.
P.O. Box 71
GR-19002 Peania
Tel.: +0030-210-66 83 400
Fax: +0030-210-66 46 273

Hong Kong

GRUNDFOS Pumps (Hong Kong) Ltd.
Unit 1, Ground floor, Siu Wai industrial
Centre
29-33 Wing Hong Street & 68 King Lam
Street, Cheung Sha Wan
Kowloon
Tel.: +852-27861706 / 27861741
Fax: +852-27858664

Hungary

GRUNDFOS South East Europe Kft.
Tópark u. 8
H-2045 Törökbalint
Tel.: +36-23 511 110
Fax: +36-23 511 111

India

GRUNDFOS Pumps India Private Limited
118 Old Mahabalipuram Road
Thoraiakkam
Chennai 600 097
Tel.: +91-44 2496 6800

Indonesia

PT GRUNDFOS Pompa
Graha intirub Lt. 2 & 3
Jln. Cillitan Besar No.454. Makasar,
Jakarta Timur
ID-Jakarta 13650
Tel.: +62 21-469-51900
Fax: +62 21-460 6910 / 460 6901

Ireland

GRUNDFOS (Ireland) Ltd.
Unit A, Merrywell Business Park
Ballymount Road Lower
Dublin 12
Tel.: +353-1-4089 800
Fax: +353-1-4089 830

Italy

GRUNDFOS Pompe Italia S.r.l.
Via Gran Sasso 4
I-20060 Truccazzano (Milano)
Tel.: +39-02-95838112
Fax: +39-02-95309290 / 95838461

Japan

GRUNDFOS Pumps K.K.
1-2-3, Shin-Miyakoda, Kita-ku
Hamamatsu
431-2103 Japan
Tel.: +81 53 428 4760
Fax: +81 53 428 5005

Kazakhstan

Grundfos Kazakhstan LLP
7' Kyz-Zhibek Str., Kok-Tobe micr.
KZ-050020 Almaty Kazakhstan
Tel.: +7 (727) 227-98-55/56

Korea

GRUNDFOS Pumps Korea Ltd.
6th Floor, Aju Building 679-5
Yeoksam-dong, Kangnam-ku, 135-916
Seoul, Korea
Tel.: +82-2-5317 600
Fax: +82-2-5633 725

Latvia

SIA GRUNDFOS Pumps Latvia
Deglava biznesa centrs
Augusta Deglava ielā 60
LV-1035, Rīga,
Tel.: +371 714 9640, 7 149 641
Fax: +371 914 9646

Lithuania

GRUNDFOS Pumps UAB
Smolensko g. 6
LT-03201 Vilnius
Tel.: +370 52 395 430
Fax: +370 52 395 431

Malaysia

GRUNDFOS Pumps Sdn. Bhd.
7 Jalan Peguam U1/25
Glenmarie industrial Park
40150 Shah Alam, Selangor
Tel.: +60-3-5569 2922
Fax: +60-3-5569 2866

Mexico

Bombas GRUNDFOS de México
S.A. de C.V.
Boulevard TLC No. 15
Parque industrial Stiva Aeropuerto
Apodaca, N.L. 66600
Tel.: +52-81-8144 4000
Fax: +52-81-8144 4010

Netherlands

GRUNDFOS Netherlands
Veluwezoom 35
1326 AE Almere
Postbus 22015
1302 CA ALMERE
Tel.: +31-88-478 6336
Fax: +31-88-478 6332
E-mail: info_gnl@grundfos.com

New Zealand

GRUNDFOS Pumps NZ Ltd.
17 Beatrice Tinsley Crescent
North Harbour Industrial Estate
Albany, Auckland
Tel.: +64-9-415 3240
Fax: +64-9-415 3250

Norway

GRUNDFOS Pumper A/S
Strømsveien 344
Postboks 235, Leirdal
N-1011 Oslo
Tel.: +47-22 90 47 00
Fax: +47-22 32 21 50

Poland

GRUNDFOS Pompy Sp. z o.o.
ul. Klonowa 23
Baranowo k. Poznania
PL-62-081 Przeźmierowo
Tel.: (+48-61) 650 13 00
Fax: (+48-61) 650 13 50

Portugal

Bombas GRUNDFOS Portugal, S.A.
Rua Calvet de Magalhães, 241
Apartado 1079
P-2770-153 Paço de Arcos
Tel.: +351-21-440 76 00
Fax: +351-21-440 76 90

Romania

GRUNDFOS Pompe România SRL
S-PARK BUSINESS CENTER, Clădirea
A2, etaj 2
Str. Tipografilor, Nr. 11-15, Sector 1, Cod
013714
Bucuresti, Romania
Tel.: 004 021 2004 100
E-mail: romania@grundfos.ro

Serbia

Grundfos Srbija d.o.o.
Omladinskih brigada 90b
11070 Novi Beograd
Tel.: +381 11 2258 740
Fax: +381 11 2281 769
www.rs.grundfos.com

Singapore

GRUNDFOS (Singapore) Pte. Ltd.
25 Jalan Tukang
Singapore 619264
Tel.: +65-6681 9688
Fax: +65-6681 9689

Slovakia

GRUNDFOS s.r.o.
Prievozská 4D 821 09 BRATISLAVA
Tel.: +421 2 5020 1426
sk.grundfos.com

Slovenia

GRUNDFOS LJUBLJANA, d.o.o.
Leskoškova 9e, 1122 Ljubljana
Tel.: +386 (0) 1 568 06 10
Fax: +386 (0) 1 568 06 19
E-mail: tehnika-si@grundfos.com

South Africa

GRUNDFOS (PTY) LTD
16 Lascelles Drive, Meadowbrook Estate
1609 Germiston, Johannesburg
Tel.: (+27) 10 248 6000
Fax: (+27) 10 248 6002
E-mail: lgradidge@grundfos.com

Spain

Bombas GRUNDFOS España S.A.
Camino de la Fuentecilla, s/n
E-28110 Algete (Madrid)
Tel.: +34-91-848 8800
Fax: +34-91-828 0465

Sweden

GRUNDFOS AB
Box 333 (Lunnagårdsgatan 6)
431 24 Mölndal
Tel.: +46 31 332 23 000
Fax: +46 31 331 94 60

Switzerland

GRUNDFOS Pumpen AG
Bruggacherstrasse 10
CH-8117 Fällanden/ZH
Tel.: +41-44-806 8111
Fax: +41-44-806 8115

Taiwan

GRUNDFOS Pumps (Taiwan) Ltd.
7 Floor, 219 Min-Chuan Road
Taichung, Taiwan, R.O.C.
Tel.: +886-4-2305 0868
Fax: +886-4-2305 0878

Thailand

GRUNDFOS (Thailand) Ltd.
92 Chaloe Phrakiat Rama 9 Road
Dokmai, Pravej, Bangkok 10250
Tel.: +66-2-725 8999
Fax: +66-2-725 8998

Turkey

GRUNDFOS POMPA San. ve Tic. Ltd. Sti.
Gebze Organize Sanayi Bölgesi
Ihsan dede Caddesi
2. yol 200. Sokak No. 204
41490 Gebze/ Kocaeli
Tel.: +90 - 262-679 7979
Fax: +90 - 262-679 7905
E-mail: satis@grundfos.com

Ukraine

ТОВ "ГРУНДФОС УКРАЇНА"
Бізнес Центр Європа
Столичне шосе, 103
м. Київ, 03131, Україна
Tel.: (+38 044) 237 04 00
Fax: (+38 044) 237 04 01
E-mail: ukraine@grundfos.com

United Arab Emirates

GRUNDFOS Gulf Distribution
P.O. Box 16768
Jebel Ali Free Zone, Dubai
Tel.: +971 4 8815 166
Fax: +971 4 8815 136

United Kingdom

GRUNDFOS Pumps Ltd.
Grovebury Road
Leighton Buzzard/Beds. LU7 4TL
Tel.: +44-1525-850000
Fax: +44-1525-850011

U.S.A.

Global Headquarters for WU
856 Koomey Road
Brookshire, Texas 77423 USA
Phone: +1-630-236-5500

Uzbekistan

Grundfos Tashkent, Uzbekistan
The Representative Office of Grundfos
Kazakhstan in Uzbekistan
38a, Oybek street, Tashkent
Tel.: (+998) 71 150 3290 / 71 150 3291
Fax: (+998) 71 150 3292

98287699 02.2025

ECM: 1417291

GRUNDFOS Holding A/S
Poul Due Jensens Vej 7
DK-8850 Bjerringbro
Tel: +45 87 50 14 00
www.grundfos.com

GRUNDFOS 