

EOM

ENGINEERING OPERATION
& MAINTENANCE MANUAL

A25PS Bolted Plastic Pump



Where Innovation Flows

WILDEN®



Copyright

Copyright 2023 PSG®, a Dover Company. All rights reserved.

PSG reserves the right to modify the information and illustrations in this document without prior notice. The product described in this document is furnished under a license agreement or nondisclosure agreement. No part of this document may be reproduced, stored in a retrieval system, or transmitted in any form or any means electronic or mechanical, including photocopying and recording, without the written permission of PSG, a Dover Company, except as described by the terms of those agreements.

This is a non-contractual document.

Trademarks

PSG and the PSG logo are registered trademarks of PSG. Wilden® is a registered trademark of PSG California LLC. Pro-Flo® SHIFT and Pro-Flo® are registered trademarks of PSG California LLC. Wil-Flex® is a trademark of PSG California LLC. Saniflex™ is a trademark of PSG California LLC.

All trademarks, names, logos and service marks (collectively “trademarks”) in this document are registered and unregistered trademarks of their respective owners. Nothing contained in this document should be construed as granting any license or right to use any trademark without the prior written permission of the trademark owner.

Warranty

Each and every product manufactured by Wilden is built to meet the highest standards of quality. Every pump is functionally tested to ensure integrity of operation. Wilden warrants that pumps, accessories and parts manufactured or supplied by it to be free from defects in material and workmanship for a period of five (5) years from date of installation or six (6) years from date of manufacture, whichever comes first.

For more information, and to register your Wilden pump for warranty, please visit <https://www.psgdover.com/wilden/support/warranty-registration>.

Certifications

CONTENTS

SECTION 1: Precautions – Read First! 4

SECTION 2: Wilden Pump Designation System 5

SECTION 3: How It Works 6

SECTION 4: Dimensional Drawings 7

SECTION 5: Performance 8

SECTION 6: Suggested Installation, Operation, Maintenance, and Troubleshooting 9

SECTION 7: Exploded View and Parts List..... 12

SECTION 8: Solenoid Control 15

SECTION 1

PRECAUTIONS – READ FIRST!



WARNING: Always wear safety glasses when operating a pump to avoid eye injury. If diaphragm rupture occurs, material being pumped may be forced out of the air exhaust.



CAUTION: Do not apply compressed air to the exhaust port – pump will not function.



CAUTION: Do not over-lubricate air supply– excess lubrication will reduce pump performance. Pump is pre-lubed.



TEMPERATURE LIMITS:

Acetal	-29°C to 82°C	-20°F to 180°F
Buna-N	-12°C to 82°C	10°F to 180°F
Geolast®	-40°C to 82°C	-40°F to 180°F
Neoprene	-18°C to 93°C	0°F to 200°F
Nordel EPDM	-51°C to 138°C	-60°F to 280°F
Nylon	-18°C to 93°C	0°F to 200°F
PFA	-7°C to 107°C	45°F to 225°F
Polypropylene	0°C to 79°C	32°F to 175°F
Polyurethane	-12°C to 66°C	10°F to 150°F
PVDF	-12°C to 107°C	10°F to 225°F
Saniflex	-29°C to 104°C	-20°F to 220°F
SIPD PTFE with EPDM-backed	4°C to 137°C	40°F to 280°F
SIPD PTFE with Neoprene-backed	4°C to 93°C	40°F to 200°F
PTFE*	4°C to 104°C	40°F to 220°F
FKM	-40°C to 177°C	-40°F to 350°F
Wil-Flex	-40°C to 107°C	-40°F to 225°F

*4°C to 149°C (40°F to 300°F) - 13 mm (1/2") and 25 mm (1") models only.

NOTE: Not all materials are available for all models. See "Wilden Pump Designation System" for material options for your pump.



CAUTION: When choosing pump materials, be sure to check the temperature limits for all wetted components. Example: FKM has a maximum limit of 177°C (350°F), but polypropylene has a maximum limit of only 79°C (175°F).



CAUTION: Maximum temperature limits are based on mechanical stress only. Certain chemicals will reduce maximum safe operating temperatures significantly. Consult the Chemical Resistance Guide for chemical compatibility and temperature limits.



WARNING: Prevent sparking — If static sparking occurs, fire or explosion could result. Pump, valves and containers must be grounded to a proper grounding point when handling flammable fluids and whenever discharge of static electricity is a hazard.



CAUTION: All Wilden pumps are capable of passing solids. Use a strainer on the pump intake to ensure that the pump's rated solids capacity is not exceeded.



CAUTION: Do not exceed 8.3 bar (120 psig) air supply pressure.



CAUTION: Do not exceed 0.7 bar (10 psig) or 7 m-H₂O (23 ft-H₂O) suction pressure.



CAUTION: Do not exceed 82°C (180°F) air inlet temperature for all models.



CAUTION: The process fluid and cleaning fluids must be compatible chemically with all wetted pump components.



CAUTION: The A25PS pump is not designed for the wet end or air end to be field serviceable.



CAUTION: Maintenance must not be performed when hazardous atmosphere is present.



CAUTION: The equipment must be inspected for visible damage prior to use.



CAUTION: Ensure pump is thoroughly cleaned and flushed prior to installation into the process line.



CAUTION: Before attaching the air line to the pump, blow out the air line for 10 to 20 seconds to make sure all pipeline debris is clear. Use an in-line air filter. A 5µ (micron) air filter is recommended.



CAUTION: Before installation, tighten all hardware.



NOTE: In the event of a power failure, close the shut-off valve if you do not want the pump to restart when the power returns.



WARNING: This product can expose you to chemicals including Nickel, Chromium, Cadmium, or Cobalt, which are known to the State of California to cause cancer and/or birth defects or other reproductive harm. For more information, go to www.P65Warnings.ca.gov.

SECTION 3

HOW IT WORKS – AIR-OPERATED DOUBLE-DIAPHRAGM PUMP

The Wilden diaphragm pump is an air-operated, positive displacement, self-priming pump. These drawings show flow pattern through the pump upon its initial stroke. It is assumed the pump has no fluid in it prior to its initial stroke.

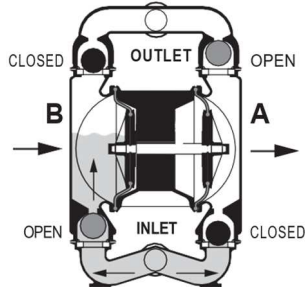

FIGURE 1 The solenoid-actuated air valve directs pressurized air to the back side of diaphragm A. The compressed air is applied directly to the liquid column separated by elastomeric diaphragms. The diaphragm acts as a separation membrane between the compressed air and liquid; a balanced load removes mechanical stress from the diaphragm. The compressed air moves the diaphragm away from the center of the pump. The opposite diaphragm is pulled in by the shaft connected to the pressurized diaphragm. Diaphragm B is on its suction stroke; air behind the diaphragm has been forced out to atmosphere through the exhaust port of the pump. The movement of diaphragm B toward the center of the pump creates a vacuum within chamber B. Atmospheric pressure forces fluid into the inlet manifold forcing the inlet valve ball off its seat. Liquid is free to move past the inlet valve ball and fill the liquid chamber (see shaded area).

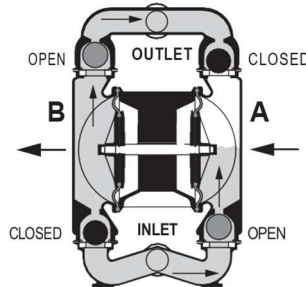

FIGURE 2 When the pressurized diaphragm, diaphragm A, reaches the limit of its discharge stroke, the air valve redirects pressurized air to the back side of diaphragm B. The pressurized air forces diaphragm B away from the center while pulling diaphragm A to the center. Diaphragm B is now on its discharge stroke. Diaphragm B forces the inlet valve ball onto its seat due to the hydraulic forces developed in the liquid chamber and manifold of the pump. These same hydraulic forces lift the discharge valve ball off its seat, while the opposite discharge valve ball is forced onto its seat, forcing fluid to flow through the pump discharge. The movement of diaphragm A toward the center of the pump creates a vacuum within liquid chamber A. Atmospheric pressure forces fluid into the inlet manifold of the pump. The inlet valve ball is forced off its seat allowing the fluid being pumped to fill the liquid chamber.

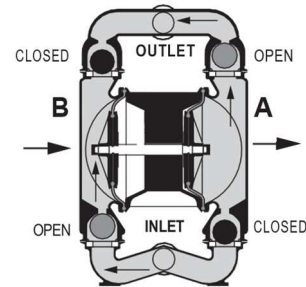
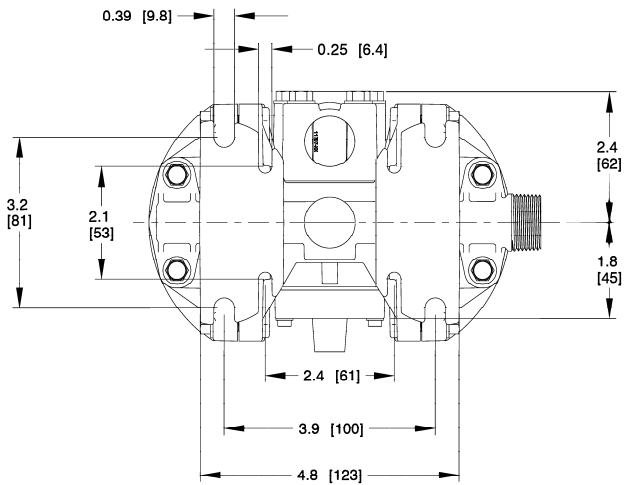
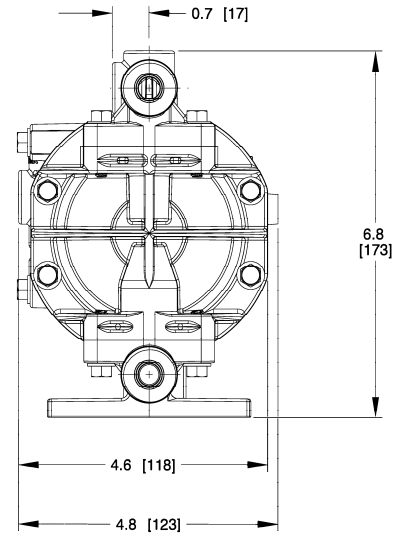
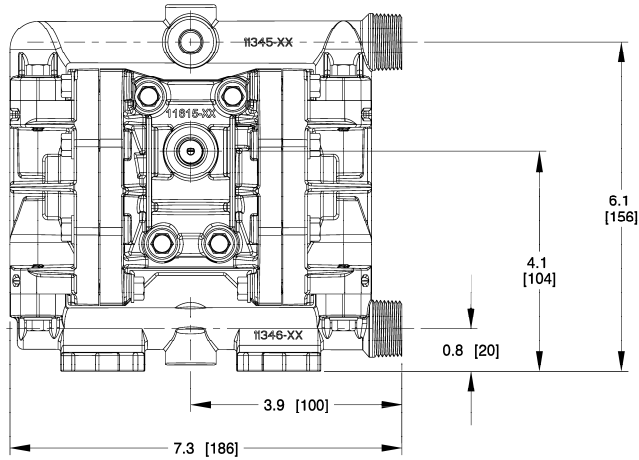

FIGURE 3 At completion of the stroke, the air valve again redirects air to the back side of diaphragm A, which starts diaphragm B on its exhaust stroke. As the pump reaches its original starting point, each diaphragm has gone through one exhaust and one discharge stroke. This constitutes one complete pumping cycle. The pump may take several cycles to completely prime depending on the conditions of the application.

SECTION 4

DIMENSIONAL DRAWING

A25PS



DIMENSIONS IN INCHES

SECTION 6

**SUGGESTED INSTALLATION, OPERATION, MAINTENANCE
AND TROUBLESHOOTING**

Wilden pumps are designed to meet the performance requirements of even the most demanding pumping applications. They have been designed and manufactured to the highest standards and are available in a variety of liquid path materials to meet your chemical resistance needs. Refer to "Performance" for an in-depth analysis of the performance characteristics of your pump. Wilden offers the widest variety of elastomer options in the industry to satisfy temperature, chemical compatibility, abrasion resistance and flex concerns.

The suction pipe size should be at least equal to or larger than the diameter size of the suction inlet on your Wilden pump. The suction hose must be a non-collapsible, reinforced type because these pumps are capable of pulling a high vacuum. Discharge piping should also be equal to or larger than the diameter of the pump discharge, which will help reduce friction losses.

 **CAUTION:** All fittings and connections must be airtight. Otherwise, pump suction capability will be reduced or lost.

Months of careful planning, study and selection efforts can result in unsatisfactory pump performance if installation details are left to chance. You can avoid premature failure and long-term dissatisfaction by exercising reasonable care throughout the installation process.

Location

Noise, safety and other logistical factors usually dictate where equipment will be situated on the production floor. Multiple installations with conflicting requirements can result in congestion of utility areas, leaving few choices for additional pumps. Within the framework of these and other existing conditions, locate every pump in such a way that the following six key factors are balanced against each other to maximum advantage:

- **Access:** First, the location should be accessible. If it's easy to reach the pump, maintenance personnel will be able to perform routine inspections and adjustments more easily. If major repairs become necessary, ease of access can play a key role in speeding the repair process and reducing total downtime.
- **Air Supply:** Every pump location should have an air line large enough to supply the volume of air necessary to achieve the desired pumping rate. For best results, the pumps should use a 5µ (micron) air filter, needle valve and regulator. The use of an air filter before the pump will ensure that the majority of any pipeline contaminants will be eliminated.
- **Solenoid Operation:** When operation is controlled by a solenoid valve in the air line, three-way valves should be used. This valve allows trapped air between the valve and the pump to bleed off, which improves pump performance. You can estimate pumping volume by counting the number of strokes per minute, and then multiplying that figure by the displacement per stroke.
- **Muffler:** Using the standard Wilden muffler, sound levels are reduced below OSHA specifications. You can use other mufflers to reduce sound levels farther, but they usually reduce pump performance.
- **Elevation:** Selecting a site that is well within the pump's dynamic lift capability will assure that loss-of-prime issues will

be eliminated. In addition, pump efficiency can be adversely affected if proper attention is not given to site location.

- **Piping:** Final determination of the pump site should not be made until the piping challenges of each possible location have been evaluated. The impact of current and future installations should be considered ahead of time to make sure that inadvertent restrictions are not created for any remaining sites.

The best choice possible will be a site involving the shortest and straightest hook-up of suction and discharge piping. Unnecessary elbows, bends and fittings should be avoided. Pipe sizes should be selected to keep friction losses within practical limits. All piping should be supported independently of the pump. In addition, the piping should be aligned to avoid placing stress on the pump fittings.

Flexible hose can be installed to aid in absorbing the forces created by the natural reciprocating action of the pump. If the pump is to be bolted down to a solid location, a mounting pad placed between the pump and the foundation will assist in minimizing pump vibration. Flexible connections between the pump and rigid piping will also assist in minimizing pump vibration. If quick-closing valves are installed at any point in the discharge system, or if pulsation within a system becomes a problem, a surge suppressor (SD Equalizer) should be installed to protect the pump, piping and gauges from surges and water hammer.

If the pump is to be used in a self-priming application, make sure that all connections are airtight and that the suction lift is within the model's ability.

When pumps are installed in applications involving flooded suction or suction head pressures, a gate valve should be installed in the suction line to permit closing of the line for pump service.

Pumps in service with a positive suction head are most efficient when inlet pressure is limited to 0.5–0.7 bar (7–10 psig). Premature diaphragm failure may occur if positive suction is 0.7 bar (10 psig) and higher.

 **CAUTION:** All Wilden pumps are capable of passing solids. Use a strainer on the pump intake to ensure that the pump's rated solids capacity is not exceeded.

 **CAUTION:** Do not exceed 8.3 bar (120 psig) air supply pressure.

SUGGESTED INSTALLATION, OPERATION, MAINTENANCE AND TROUBLESHOOTING

This illustration is a generic representation of an air-operated double-diaphragm pump

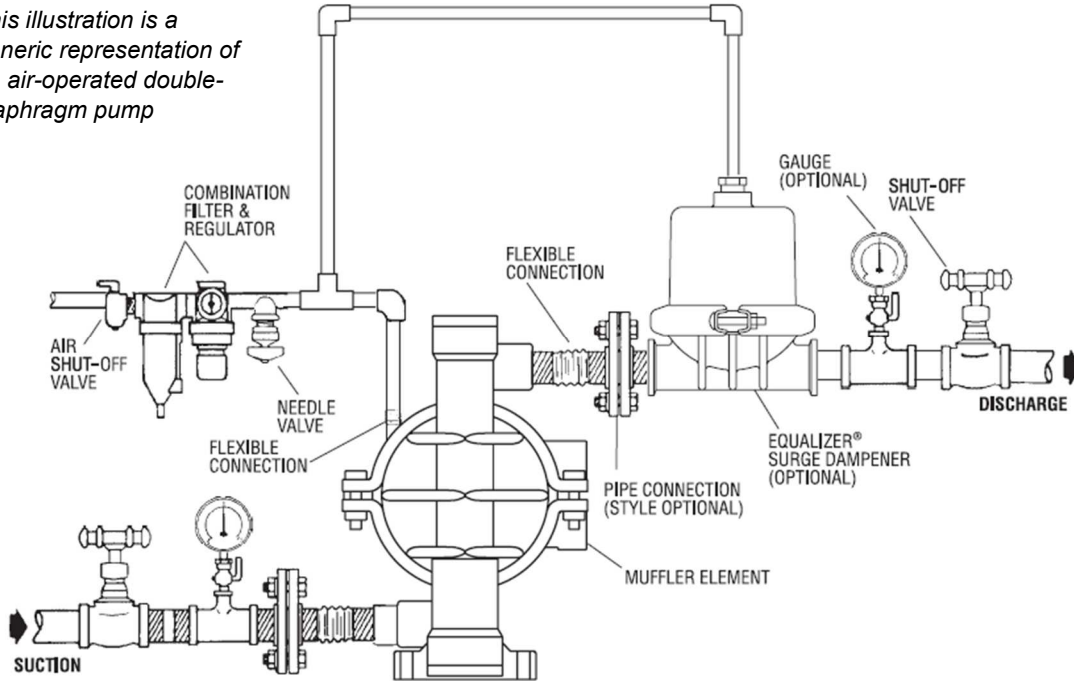

! **NOTE:** In the event of a power failure, close the shut-off valve if you do not want the pump to restart when the power returns.

Air-Operated Pumps: To stop the pump from operating in an emergency, simply close the shut-off valve (user-supplied) installed in the air supply line. A properly functioning valve will stop the air supply to the pump, therefore stopping output. This shut-off valve should be located far enough away from the pumping equipment such that it can be reached safely in an emergency.

Operation

The Air-Operated Double Diaphragm Pump requires a minimum of 20 psig of air to operate, with some variation according to diaphragm material.

Solenoid control of the inlet air is used in order to facilitate remote operation. A three way solenoid valve is recommended, in order to allow the air to “bleed off” between the solenoid and the pump. Do not use valves for flow control on the suction side of the pump. (Closing or partially closing a liquid suction valve restrict the suction line and may cause damage to the diaphragms.) Suction strainers may be employed to reduce or eliminate larger solids, but routine maintenance is necessary in order to prevent a restriction on the suction.

Maintenance and Inspections

Due to the unique nature of each application, periodic inspection of the pump is the best method to determine a proper maintenance schedule. A record should be kept of all repairs made to an installed pump. This will serve as the best predictor of future maintenance.

The A25PS pump is not designed for the wet end or air end to be field serviceable.

Maximum Torque Specifications

	Torque	Wrench Size
Manifold Bolts	6.8 N·m (60 in-lb)	3/8 in.
Polypropylene Chamber	6.8 N·m (60 in-lb)	3/8 in.
Polypropylene Chamber with PTFE Diaphragms	7.1 N·m (62.5 in-lb)	3/8 in.
PVDF Chamber	7.1 N·m (62.5 in-lb)	3/8 in.
PVDF Chamber with PTFE Diaphragms	7.1 N·m (62.5 in-lb) (Qty 12) 9.0 N·m (80 in-lb)* (Qty 4)	3/8 in.
Air Valve	4.5 N·m (40 in-lb)	3/8 in.
Diaphragm Plates	4.5 N·m (40 in-lb)	3/4 in.

* **Note:** Torque the 2 bottom bolts on each side of intermediate and outer chambers (4 total) at 9.0 N·m (80 in-lb) to create a proper seal.

SUGGESTED INSTALLATION, OPERATION, MAINTENANCE AND TROUBLESHOOTING

Troubleshooting

Pump will not run or runs slowly.

1. Remove plug from pilot spool exhaust.
2. Ensure that the air inlet pressure is at least 0.4 bar (5 psig) above startup pressure and that the differential pressure (the difference between air inlet and liquid discharge pressures) is not less than 0.7 bar (10 psig).
3. Check air inlet filter for debris (see "Suggested Installation, Operation, Maintenance and Troubleshooting").
4. Check for extreme air leakage (blow by) that would indicate worn seals/bores in the air valve, pilot spool and main shaft.
5. Disassemble the pump and check for obstructions in the air passageways or objects that would obstruct the movement of internal parts.
6. Check for sticking ball check valves.
 - a. If material being pumped is not compatible with pump elastomers, swelling may occur. Replace ball check valves and seals with proper elastomers.
 - b. Also, as the check valve balls wear out, they become smaller and can become stuck in the seats. In this case, replace balls and seats.
7. Check for any broken inner piston that would cause the air valve spool to be unable to shift.

Pump runs, but little or no product flows.

1. Check for pump cavitation. Slow pump speed down to allow thick material to flow into liquid chambers.
2. Verify that vacuum required to lift liquid is not greater than the vapor pressure of the material being pumped (cavitation).
3. Check for sticking ball check valves.
 - a. If material being pumped is not compatible with pump elastomers, swelling may occur. Replace ball check valves and seals with proper elastomers.
 - b. Also, as the check valve balls wear out, they become smaller and can become stuck in the seats. In this case, replace balls and seats.

Pump air valve freezes.

1. Check for excessive moisture in the compressed air.
 - a. Either install a dryer or a hot air generator for compressed air.
 - b. Alternatively, you may use coalescing filter to remove the water from the compressed air in some applications.

Air bubbles in pump discharge.

1. Check for a ruptured diaphragm.
2. Check tightness of outer pistons (see "Disassembly/Reassembly").
3. Check tightness of fasteners and integrity of O-rings and seals, especially at intake manifold.
4. Ensure pipe connections are airtight.

Product comes out air exhaust.

1. Check for a diaphragm rupture.
2. Check the tightness of the outer pistons to the shaft.

SECTION 7

EXPLODED VIEW AND PARTS LIST

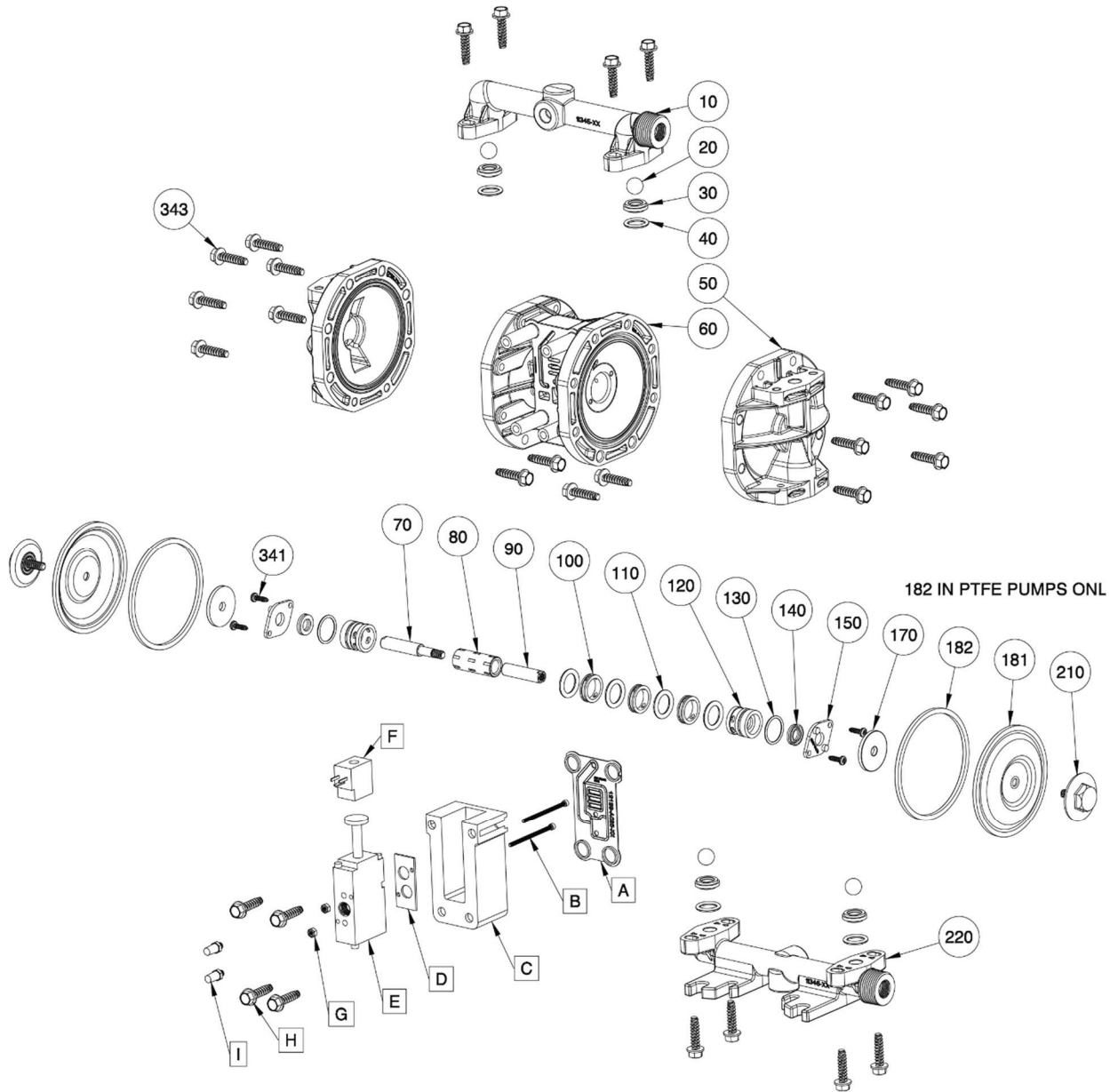

EXPLODED VIEW AND PARTS LIST

Item	DESCRIPTION	QTY	PUMP MODEL	PART NO.	MATERIAL
10	DISCHARGE MANIFOLD	1	A25PS/PPPPP/***/P/**	11345-W-40	Polypropylene
			A25PS/KPPPP/***/P/**	11345-W-56	PVDF
20	BALL	4	A25PS/*PPPP/***/WF/P/**	11001-23	Santoprene
			A25PS/*PPPP/***/TF/P/**	11001-59	PTFE
30	VALVE SEAT	4	A25PS/*PPPP/***/P/**	10924-ROD-40	Polypropylene
40	O-RING (Valve Seat)	4	A25PS/*PPPP/***/P/BN	11954-11	BUNA-N
			A25PS/*PPPP/***/P/VT	11954-13	FKM
			A25PS/*PPPP/***/P/EP	11954-15	EPDM
			A25PS/*PPPP/***/P/TF	11954-17	PTFE
50	OUTER CHAMBER	2	A25PS/PPPPP/***/P/**	10728-40	Polypropylene
			A25PS/KPPPP/***/P/**	10728-56	PVDF
60	INTERMEDIATE	1	ALL MODELS	11502-40	Polypropylene
70 & 90	DIAPHRAGM ROD ASSEMBLY	1	ALL MODELS	35008-00	Stainless Steel
80	PILOT SLEEVE	1	ALL MODELS	10109-31	Acetal
100	INNER SPACER (Pilot Sleeve)	3	ALL MODELS	10211-40	Polypropylene
110	O-RING (Pilot Sleeve)	4	ALL MODELS	11929-16	Urethane
120	END SPACER (Pilot Sleeve)	2	ALL MODELS	10210-40	Polypropylene
130	O-RING (End Spacer)	2	ALL MODELS	11955-11	Nitrile
140	LIP SEAL (Diaphragm Rod)	2	ALL MODELS	12005-76	Nitrile
150	RETAINING PLATE	2	ALL MODELS	12710-A025-60	Polypropylene
170	INNER DIAPHRAGM PLATE	2	ALL MODELS	11105-25	Plated Steel
181	DIAPHRAGM	2	A25PS/*PPPP/ZGS/***/P/**	10604-19	Geolast
			A25PS/*PPPP/WFS/***/P/**	10604-23	Santoprene
			A25PS/*PPPP/TSU/***/P/**	10604-59	PTFE
182	DIAPHRAGM O-RING (PTFE ONLY)	2	A25PS/*PPPP/TSU/***/P/**	10606-23	Santoprene
210	OUTER DIAPHRAGM PLATE W/ THREADED STUD	2	A25PS/PPPPP/***/P/**	11205-A025-40	Polypropylene
			A25PS/KPPPP/***/P/**	11205-A025-56	PVDF
220	SUCTION MANIFOLD	1	A25PS/PPPPP/***/P/**	11346-40	Polypropylene
			A25PS/KPPPP/***/P/**	11346-56	PVDF
341	SCREW (#6 x 1/2")	4	ALL MODELS	12510-26	Stainless Steel
343	SCREW (1/4" - 10 x 1")	28	ALL MODELS	12562-26	Stainless Steel

* Sold as part of 56000-00, Submersion Kit

EXPLODED VIEW AND PARTS LIST

SOLENOID CONTROL VALVE

Item	Part Number	Description	QTY
A	12128-A025-11	Gasket-Air Valve-A025-Buna	1
B	12591-26	Screw-SHCS #4-40X2.00"-SS	2
C	13456-31	Adapter-Plate-Solenoid-A025	1
D	12132-11	Gasket-Solenoid-A025-Buna	1
E	13453-00	Valve-Solenoid-4-Way-A025	1
F	13454-10	Coil-Solenoid-A025 - 110 VAC	1
	13454-12	Coil-Solenoid-A025 - 12 VDC	1
	13454-20	Coil-Solenoid-A025 - 220 VAC	1
	13454-24	Coil-Solenoid-A025 - 24 VDC	1
G	12592-26	Nut-Hex-Nylock-#4-40-SS	2
H	12562-26	Screw-HWHSTF-1/4-10x1.00"-SS	4
I	13117-00	MUFFLER-1/8"NPT-POLY	2

SECTION 8

SOLENOID CONTROL

A25PS PLASTIC SOLENOID CONTROL

The A25PS is configured with solenoid pulse control to enable metering and dispensing application. The solenoid is available in 4 voltages, 110 VAC, 220 VAC, 12 VDC and 24 VDC. All solenoid equipped pumps have a standard DIN 43650B male connector. The A25PS has an optional DIN 43650C male connector that can replace the standard DIN 43650B male connector. See pump product manual for configuration codes.

SOLENOID ELECTRICAL PROPERTIES				
Voltage +/- 10%	Current (Amps)		Resist. (OHMS @ 25°C)	Power (AC = VA, DC = Watts)
	Inrush	Holding		
110/50 110/60	.02	.02	2310	2.4
220/50 220/60	.01	.01	9515	2.4
12 VDC	.15	.15	78	2.0
24 VDC	.09	.09	283	2.0

Valve Operation

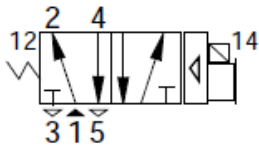
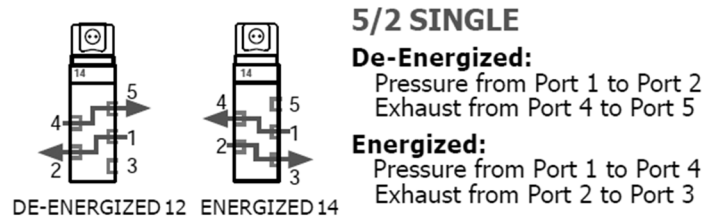

OPTIONAL ACCESSORIES	
Part No.	Description
13465-00	Illuminated Connector with 6' cord for 110/220 VAC Solenoid
13466-00	Illuminated Connector with 6' cord for 12/24 VDC Solenoid

WILDEN®

PSG
22069 Van Buren Street
Grand Terrace, CA 92313-5651 USA
P: +1 (909) 422 -1730
psgdover.com



Where Innovation Flows

PSG® reserves the right to modify the information and illustrations contained in this document without prior notice. This is a non-contractual document.