

Please read and save this Repair Parts Manual. Read this manual and the General Operating Instructions carefully before attempting to assemble, install, operate or maintain the product described. Protect yourself and others by observing all safety information. The Safety Instructions are contained in the General Operating Instructions. Failure to comply with the safety instructions accompanying this product could result in personal injury and/or property damage! Retain instructions for future reference. AMT reserves the right to discontinue any model or change specifications at any time without incurring any obligation.

©2012 American Machine & Tool Co., Inc. of PA, A Subsidiary of The Gorman-Rupp Company, All Rights Reserved.

Periodic maintenance and inspection is required on all pumps to insure proper operation. Unit must be clear of debris and sediment. Inspect for leaks and loose bolts. Failure to do so voids warranty.

Hand Operated Diaphragm Pump



DESCRIPTION

This diaphragm pump is a hand operated and self-priming portable unit. Shipped completely assembled. For use with liquids compatible with pump component materials.

SPECIFICATIONS

Suction Inlet.....1 or 1 ½" Smooth Hose†
 Discharge Outlet.....1 or 1 ½" Smooth Hose†
 Basic Construction.....Delrin®
 Diaphragm.....Buna
 Flapper Check Valves.....Buna
 Max Temperature.....130F
 Max Pressure.....2 PSI
 Flow.....Up To 12 GPM @ 90 Strokes/Minute

IMPORTANT: NOT FOR USE IN CLOSED LOOP SYSTEM

† 1" Size installed from factory, optional 1 ½"

GENERAL SAFETY INFORMATION

Included with pump, refer to maintenance section for proper installation of hand optional ports.

- When using a hand pump, follow all electrical and safety codes, as well as the Occupational Safety and Health Act (OSHA), most recent United States National Electrical Code (NEC), National Fire Protection Association, Inc (NFPA) codes, local codes and ordinances, as needed in a particular application.
- Know the pump application, limitations and potential hazards. The "Warning" statements indicate potentially hazardous conditions for the operator or equipment. TAKE NECESSARY STEPS TO PROTECT PERSONNEL AND EQUIPMENT.
 Pump should only be used with liquids compatible with pump component materials. The chemical supplier should be consulted regarding any questions of chemical compatibility, proper and safe use, and handling of chemical. Misapplication of pump using non-compatible liquids will void warranty.

▲ WARNING

Do not use to pump flammable or explosive fluids such as gasoline, fuel oil, kerosene, etc. Do not use in flammable and/or explosive atmospheres. Pump should only be used with liquids compatible with pump component materials. Failure to follow this warning can result in personal injury and/or property damage.

In order to safely use this product, familiarize yourself with this pump and also with liquid (chemical, etc.) that is going to be pumped through the unit. Although this pump is suitable for many liquids, it is not suitable for all liquids!

- Provide adequate protection and guarding around moving parts.
- Release all pressure within the system before servicing any component.
- Drain all liquids from the system before servicing.
- Do not over tighten threaded fittings. One full turn past hand tight is usually enough to prevent leakage. Teflon sealant tape should be used on all threaded joints.

- Secure the discharge line before starting the pump. An unsecured discharge line will whip possible causing personal injury and/or property damage.
- Check hose for weak or worn condition before each use, making certain that all connections are secure.
- Periodically inspect pump and system components. Performance routine maintenance as required.
- Provide a pressure relief system on pumps whose discharge line can be shut-off or obstructed.
- Personal Safety:**
 - Wear safety glasses at all times when working with pumps
 - Wear a face shield and proper apparel when pumping hazardous chemicals.
 - Keep work area clean, uncluttered and properly lighted; replace all unused tools and equipment.
 - Keep visitors at a safe distance from the work area.
 - Make workshop child-proof with padlocks, master switches, and by removing starter keys.

▲ WARNING

Failure to follow all General Safety Information can result in a fatality, personal injury and/or property damage!

ASSEMBLY

- Inspect unit to see that no parts are missing or broken in shipment.
- Attaching pump to a wood or equivalent base in the (4) hole provided on pump will ease operation of the manual pump.
- Place pump on a solid foundation, located as close as possible to the fluid being pumped, making the suction line short, straight, and direct as possible.
- Optional Ports:
 - Each HP01-99 comes with 1" ports installed. Optional 1 ½" ports are included and can be installed by owner as described in Maintenance Section, Section 2, Flapper Valve removal. Follow and complete instructions and replace both suction and discharge. Failure to do so can cause damage to pump and void warranty.
- Attached suction piping to the suction inlet and discharge piping to the discharge outlet. Suction line should be positioned such that there us a continual upward slope from the fluid source to the pump. Avoid using loops or sections of pipe or fittings which might permit air to become trapped.

IMPORTANT: Be sure to use the same size 1" or 1 ½" reinforced hose on both the suction and discharge. DO NOT USE canvas or similar collapsible materials. Suction line must be air tight so that air cannot leak in and destroy priming vacuum. On a permanent installation where piping is used, always connect a piece of flexible hose between pump and piping so pump is free to move slightly. Assure airtight pipe connections with the use of a rope joint sealant.

- Use a strainer on the inlet end of the suction hose or pipe at all times to prevent damage. Keep the strainer clean. If possible, suspend it to keep it from becoming clogged with foreign objects. Keep hose free of kinks as they will restrict flow and add excess loading to the pump.

MAINTENANCE

- When the pump has been used it is possible that sand or other foreign particles may build up under the diaphragm. This will limit the stroke and reduce the flow. When and if this should happen remove the handle assembly (Ref No. 1) then the screws and nuts holding the clamp ring (Ref No. 6) to the diaphragm casings (Ref No. 6). Remove the entire assembly as one unit and clean the foreign object(s) from the diaphragm casing and reassemble as before.
- To replace a faulty flapper check valve remove the six screws and nuts from the inlet housing (Ref No. 5) or the discharge housing (Ref No. 5). Remove old Adhesive/sealant from flange faces; be careful to avoid damaging face of each flange. Apply a thin film of adhesive/sealant (3M #847 or equivalent) to entire face of both flanges and replace the flapper check valves (Ref No. 4). Replace inlet or discharge housing.

NOTE: Recommend to replace both flapper check valves.

- To replace a faulty diaphragm, remove the handle assembly screw and nut (Ref No. 1). Remove the (12) screws and nuts holding the clamp ring (Ref No. 6) to the base. Remove the entire assembly. Remove the screw from the plunger and remove the diaphragm plate (Ref No. 2) and the diaphragm (Ref No. 3). Remove old adhesive/sealant from plunger; be careful to avoid damaging plunger face. Apply a thin film of adhesive/sealant (3M #847 or equivalent) to plunger face in a small circular shape around perimeter of center screw boss. Replace the diaphragm and reassembly as before. Before tightening, make sure the hole in the diaphragm are aligned with the holes in the clamp ring then tighten.

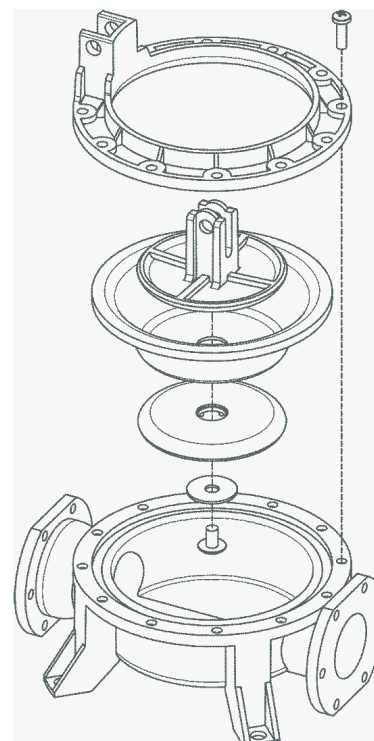

Figure 1 – Diaphragm Assembly

Troubleshooting Chart

Symptom	Possible Cause(s)	Corrective Action
Pump does not prime	<ol style="list-style-type: none"> Suction tube clogged Inlet screen/strainer clogged Air leakage Diaphragm leaking Valve leakage 	<ol style="list-style-type: none"> Clean suction tube Clean inlet screen/strainer Verify that the connection to the inlet housing is sealed tight Replace the diaphragm Inspect flapper valves for tears or holes, replace as required
Insufficient flow	<ol style="list-style-type: none"> Possible cause for "Pump does not prime" (see above) Clogged suction or discharge hose Foreign objects under diaphragm limiting the stroke Pinched or kinked inlet or discharge hose 	<ol style="list-style-type: none"> Check and repair as necessary Clean hose or hoses Remove the diaphragm and clean the chamber Replace or straighten hose as required

For Repair Parts contact dealer where pump was purchased.

Please provide following information:

-Model Number

-Serial Number (if any)

Part description and number as shown in parts list

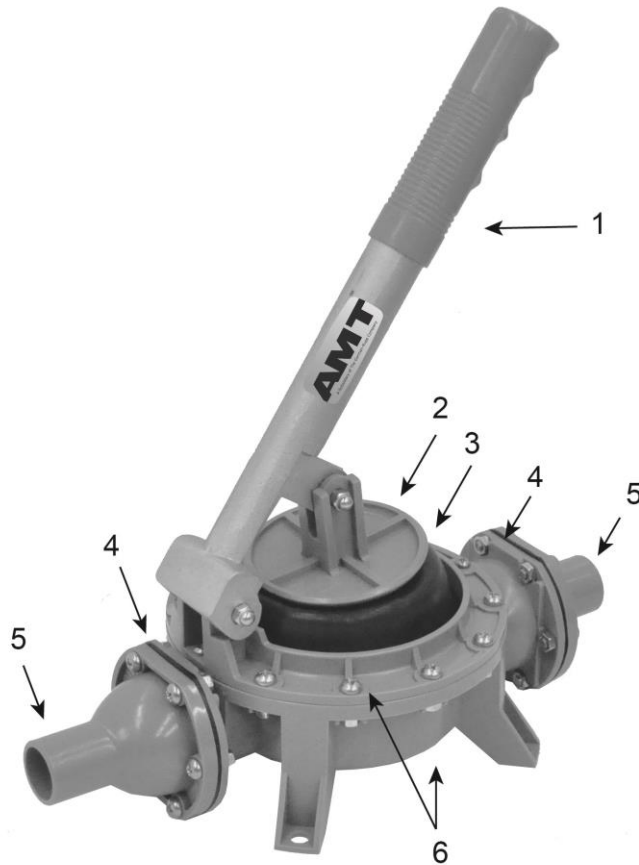

Figure 2 – Repair Parts Illustration

Repair Parts List

Ref. No.	Description	Part Number	Qty.
1	Handle Kit (Includes Handle, Grip, & Hardware)	HP01-100-90	1
2	Diaphragm Kit	HP01-070-90	1
3	Plunger & Diaphragm Plate Kit	HP01-010-90	1
4	Flapper Check Valve Kit (2)	HP01-071-90	1
5	Port Kit 1" Kit (2)	HP01-050-90	1
	Port Kit 1 1/2" Kit (2)	HP01-051-90	1
6	Body Assembly (Clamp Ring & Base)	Replace Pump	N/A

IMPORTANT NOTES:

A Replace all hardware locally; not available unless included with kits noted above.

B See maintenance section for proper replacement and installation

NOTE: The required 3M #847 or equivalent is not included with replacement parts.



American Machine & Tool Co., Inc. of PA
(herein "AMT")
400 Spring Street
Royersford, PA 19468
Phone: (610) 948-3800
Fax: (610) 948-5300
www.amtpump.com

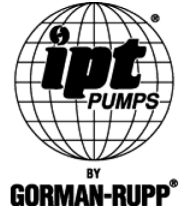

General Information

SALES POLICY: AMT products are sold through our established Distributors. We do not sell direct to the consumer or organization not entitled to trade recognition. Therefore, possession of our catalogs and/or price list(s) does not infer an offer to sell.

MINIMUM ORDER: We appreciate your order, however, all orders are subject to a minimum \$35.00 net invoice charge (excluding freight). This applies to all pump and parts purchase orders.

PRICES: Prices are subject to change without notice. All orders accepted are subject to prices in effect at time of shipment.

PAYMENT TERMS: Terms, upon establishment of credit, are Net 30 days. Past due accounts may be subject to a service charge of 1.5% per month. Domestic or assignable letter of credit is required for all export trade.

PAST DUE ACCOUNTS: AMT reserves the right to withhold open account shipments on any past due account. Invoices are considered past due after thirty (30) days. In the interest of sound business, all orders are subject to approval of the Credit Department.

SHIPPING INSTRUCTIONS: All shipments will be made F.O.B. the factory. Where instructions for shipment do not appear on the order, the shipment will be made according to our best judgment. Full risk of loss (including transportation delays and losses) shall pass to the customer upon delivery of the products to the carrier at the F.O.B. point. When loss or delay occurs, primary responsibility for tracing rests with the customer. When there is LOSS or APPARENT VISIBLE DAMAGE to a shipment, when tendered for delivery, *DO NOT* give the carrier a clear receipt. Note such damage on the carrier's delivery receipt and *HAVE THE DRIVER SIGN THE RECEIPT.*

PRODUCT REVISIONS: AMT reserves the right to discontinue, change or improve its products or any portions thereof without being obligated to provide such a change or improvement for units sold and/or shipped prior to such a change or improvement.

LEAD TIME: Products designated "Quick Ship Product", also referred to as "QSP" will normally be shipped within 24 hours of receipt of a non-cancellable purchase order. Only limited quantities of "QSP" pumps are available.

STANDARD LEAD TIME: Lead time is two weeks for all non "QSP" product. AMT reserves the right to revise lead times as required due to availability of materials and all other causes beyond our control.

VIP SHIPMENT: Select AMT and IPT branded pumps are available for next day shipment for non-QSP (Quick Ship Products) items and subjected to a specific model surcharge per unit noted in the respective price book. Requires calling for availability, confirmation and a non-cancellable purchase order or credit card payment prior to shipment. The expedited shipping charges are an additional cost added separately from the VIP charges per item. AMT reserves the right to revise lead times as required due to availability of materials and all other causes beyond our control. QSP quantities are limited as determined by AMT.

ALL purchase orders must be submitted via hard copy sent to AMT customer service department by fax, EDI or e-mail.

RETURN GOODS POLICY: Goods shall not be returned without a return goods authorization number (RGA) issued by AMT customer service. The RGA number must be listed on the packing list. Only current model and part numbers with a valid date code may be returned (within one year from date of purchase). **A 20% restocking and packaging charge will apply to all returns. All shipping charges must be pre-paid. No exceptions.**

ORDER CHANGES BY CUSTOMER: Orders in process may not be changed except with written consent and may be subject to special charges.

12 Month Limited Warranty

EXTENT AND DURATION OF LIMITED WARRANTY

Coverage: American Machine & Tool Company (herein "AMT") or IPT Pumps by Gorman-Rupp (herein "IPT") or Gorman-Rupp Industries Division of The Gorman-Rupp Company, Patterson, or the Gorman-Rupp Company (herein referred to as "G-R Unit") each individually warrants that its products and parts shall be free from defects in material and workmanship for twelve (12) months from the date of purchase by the original end user when installation is made and maintenance is performed in accordance with G-R Unit's recommendations. Wear and tear resulting from use and items normally consumed in use are not covered.

EXCEPTIONS

(A) This Limited Warranty shall not apply to mechanical seals in AMT or IPT pumps and the following products and parts: engines, motors, trade accessories and all other products, components, parts and materials not manufactured by the G-R Units. These items may, however, be covered by the warranties of their respective manufacturers. (B) This warranty does not extend to or apply to any unit which has been repaired or altered at any place other than by a G-R Unit, or by persons not expressly approved by a G-R Unit to make repairs or alterations, nor to any unit the serial number, model number or identification of which has been removed, defaced or altered. (C) This warranty does not extend to any product manufactured by a G-R Unit, which has been subjected to mis-use, neglect, accident, improper installation, or use in violation of instructions furnished by a G-R Unit. (D) Pump Kits: This warranty does not extend to any product sold by a G-R Unit unassembled as a Pump Kit. Pump Kits are warranted against defects in material and workmanship for 60 days from the date of shipment from a G-R Unit. Any Pump Kit parts deemed defective by a G-R Unit will be replaced free of charge within 60 days of shipment. Pump Kits are not returnable for credit.

LIMITATIONS

THE G-R UNITS' SOLE AND EXCLUSIVE WARRANTY WITH RESPECT TO THEIR PRODUCTS AND PARTS IS THIS LIMITED WARRANTY. THIS LIMITED WARRANTY IS IN LIEU OF ALL OTHER EXPRESS AND/OR IMPLIED WARRANTIES, INCLUDING IMPLIED WARRANTIES OF MERCHANTABILITY AND FITNESS FOR PARTICULAR PURPOSE.

EXCLUSIVE REMEDY AND DAMAGES

The sole and exclusive remedy for breach of this Warranty by a G-R Unit and the entire extent of its liability for such breach or for damages arising from the use of the products and parts covered under this Limited Warranty, shall be as follows:

- Repair or Replacement:** If inspection shows that any G-R Unit product or part covered under this Limited Warranty is defective in materials or workmanship, the G-R Unit shall repair or replace the defective or non-conforming product or part without charge, whichever the G-R Unit chooses. You must have properly maintained and used the product or part claimed to be defective in accordance with the maintenance schedule or manual, which comes with the product. No allowance will be made for labor, installation, removal, transportation or other charges incurred by you in connection with such repair or replacement.
- To obtain the above remedy:
 - Immediately notify the G-R Unit upon discovery of the claimed defect in materials or workmanship and provide the serial number or date code of the product and/or part(s) or provide the G-R Unit with the invoice or bill of sale referencing the product by no later than the expiration date of the warranty period.
 - The G-R Unit will advise whether inspection will be necessary and how whether repair or replacement will be made. If inspection by the G-R Unit is necessary, the pump or defective part must be sent freight pre-paid to the G-R Unit. Return shipment will be F.O.B. the G-R Unit's plant.
 - Return Goods Authorization Requirement:** No product will be accepted for return or replacement without the prior written authorization of the G-R Unit. Upon such authorization, and in accordance with instructions from the G-R Unit, the product will be returned to the G-R Unit, shipping charges prepaid by the Buyer.
- Damages:** The G-R Unit's liability for damages for breach of this Limited Warranty shall not exceed the amount of the purchase price of the product or part(s) in respect to which Such damages are claimed. **IN NO EVENT SHALL THE G-R UNITS BE LIABLE FOR INCIDENTAL, CONSEQUENTIAL OR SPECIAL DAMAGES FOR BREACH OF THIS LIMITED WARRANTY.**

Some states do not allow the exclusion or limitation of incidental or consequential damages, so the above limitation or exclusion may not apply to you. This Limited Warranty gives you specific legal rights, and you may also have other rights, which vary from state to state.