

BALDOR® • ***RELIANCE***

Product Information Packet

CTM1765T

40/10HP, 1775/885RPM, 3PH, 60HZ, 324T, TEFC

Part Detail							
Revision:	M	Status:	PRD/A	Change #:		Proprietary:	No
Type:	AC	Prod. Type:	1262M	Elec. Spec:	12WGW968	CD Diagram:	CD0032
Enclosure:	TEFC	Mfg Plant:		Mech. Spec:	12F707	Layout:	12LYF707
Frame:	324T	Mounting:	F1	Poles:	04/08	Created Date:	10-29-2009
Base:	RG	Rotation:	R	Insulation:	F	Eff. Date:	02-24-2016
Leads:	6#8					Replaced By:	
Literature:		Elec. Diagram:					

Nameplate NP2178E											
CAT.NO.	CTM1765T										
SPEC.	12F707W968										
HP	40/10										
VOLTS	460										
AMP	48/18.6										
RPM	1760/870										
FRAME	324T				HZ	60		PH	3		
SER.F.	1.15			CODE	H	DES	A		CL	F	
NEMA-NOM-EFF				PF							
RATING	40C AMB-CONT										
CC									USABLE AT 208V		
DE	6312				ODE	6312					
ENCL	TEFC			SN							

Parts List		
Part Number	Description	Quantity
SA187301	SA 12F707W968	1.000 EA
RA175068	RA 12F707W968	1.000 EA
S/P107-000-004	SUPER-E(284 FR. & UP)-CL PLANT,POLYREX E	1.000 EA
10CB1000A04E	CONDUIT BOX, MACH W/E-COAT	1.000 EA
09GS1010	GASKET, DWG, LEADWIRE SEPERATOR	1.000 EA
10XN3118K16	5/16-18 X 1' GRADE #5, STL, ZINC PLATE	4.000 EA
HW1001A31	LOCKWASHER 5/16, ZINC PLT.591 OD, .319 I	4.000 EA
WD1000B16	T&B CX70TN TERMINAL	1.000 EA
10XN2520K08	1/4-20 X .50 GRADE #5, STL, ZINC PLATE	1.000 EA
HW1001A25	LOCKWASHER 1/4, ZINC PLT .493 OD, .255 I	1.000 EA
HA4017A10	1/8X1.25 GREASE EXT (F/S)	1.000 EA
HW4019A01	PIPE COUPLING 1/8 NPT,STEEL,ZINC COATING	1.000 EA
HA4017A01	1/8 X 4 GREASE EXT (F/S)	1.000 EA
HA3400A13	STUD, 1/2-13 X 7" WELKER	4.000 EA
HW4600A90	SEAL 2.125 X 2.875 X 0.375 SINGLE LIP	1.000 EA
HA1005A06	SLINGER, OD 3.62, ID 2.15	1.000 EA
HW5100A15	W4997-050 WVY WSHR (WB)	1.000 EA
10XN3118K40	5/16-18 X 2.50" HEX HD, GRADE 5	4.000 EA
12FH1002A33E	FAN COVER, MACH ,E-COAT	1.000 EA
12EP1106A40E	PUEP, MACH FOR OIL SEAL W/E-COAT	1.000 EA
10XN5013K28	1/2-13 X 1.75 HEX HEAD MACH SCREW,GRAD	4.000 EA
HW1001A50	LOCKWASHER 1/2, ZINC PLT.,.879 OD, .509 I	4.000 EA
HW4600B37	SEAL 2.250 X 3.000 X .375 SINGLE LIP	1.000 EA
HW4600B41	V-RING SLINGER 2.125 X 2.880 X 0.280	1.000 EA

Parts List (continued)		
Part Number	Description	Quantity
10XN3118K40	5/16-18 X 2.50" HEX HD, GRADE 5	4.000 EA
XY5013A12	NUT,1/2-13,HEX,STEEL,ZINCPLATED	4.000 EA
HW1001A50	LOCKWASHER 1/2, ZINC PLT.,.879 OD, .509 I	4.000 EA
HW1001A50	LOCKWASHER 1/2, ZINC PLT.,.879 OD, .509 I	4.000 EA
10CB1503A01P	CONDUIT BOX LIPPED LID, MACH W/EPXY PRMR	1.000 EA
14GS1003	GASKET CONDUIT BOX LID, NEOP	1.000 EA
10XN2520K16	1/4-20 X 1" HX HD SCRW GRADE 5, ZINC P	4.000 EA
HW1001A25	LOCKWASHER 1/4, ZINC PLT .493 OD, .255 I	4.000 EA
HW2501H33	KEY, 1/2 SQ X 3.875	1.000 EA
MJ5001A27	32220KN GRAY SEALER *MIN BUY 4 QTS=1GAL	0.031 QT
MJ5001A14	DYNAPRO SEAL, CP MOTORS VC#2508050 (603	0.030 EA
LB1115N	LABEL,LIFTING DEVICE (ON ROLLS)	1.000 EA
LB1002N	LABEL,MARINE DUTY (ON ROLLS)	1.000 EA
12EP1111A17GE6	FR ENDPLATE, MACH W/E-COAT & PAINT	1.000 EA
MN416A01	TAG-INSTAL-MAINT no wire (1200/bx) 11/14	1.000 EA
HW4500A17	317400 ALEMITE GREASE RELIEF	1.000 EA
HW4500A21	1618BALEMITE FITTING 825 UNIVERSAL	1.000 EA
HA4051A00	PLASTIC CAP FOR GREASE FITTING	1.000 EA
HA4054	SHORT T-DRAIN FITTING, .125" N.P.T.	1.000 EA
09FN3001B03SP	EXTERNAL FAN, PLASTIC	1.000 EA
HA4054	SHORT T-DRAIN FITTING, .125" N.P.T.	1.000 EA
MJ1000A02	GREASE, POLYREX EM EXXON (USe 4824-15A)	0.200 LB
HW4500A17	317400 ALEMITE GREASE RELIEF	1.000 EA
HW4500A03	GREASE FITTING, .125 NPT 1610(ALEMITE) 8	1.000 EA

Product Information Packet: CTM1765T - 40/10HP,1775/885RPM,3PH,60HZ,324T,TEFC

HA4051A00	PLASTIC CAP FOR GREASE FITTING	1.000 EA
HW2500A25	WOODRUFF KEY USA #1008 #BLOW CARBON STEE	1.000 EA
51XB1214A20	12-14X1.25 HXWSSLD SERTYB	1.000 EA
MG1025N19	WILKOFEST, 778.50, RELIANCE BLUE-GREEN	0.080 GA
85XU0407S04	4X1/4 U DRIVE PIN STAINLESS	2.000 EA
LB1119N	WARNING LABEL	1.000 EA
LC0032	CONNECTION LABEL	1.000 EA
NP2178E	SS CP SUPER-E UL CSA CC	1.000 EA
12PA1000	PACKAGING GROUP PRINT PK1024A06	1.000 EA

AC Induction Motor Performance Data

Record # 3275 - Typical performance - not guaranteed values

Winding: 12WGW968-R001	Type: 1262M	Enclosure: TEFC
-------------------------------	--------------------	------------------------

Nameplate Data				460 V, 60 Hz: High Speed Connection	
Rated Output (HP)	40/10			Full Load Torque	119 LB-FT
Volts	460			Start Configuration	direct on line
Full Load Amps	48/18.6			Breakdown Torque	382 LB-FT
R.P.M.	1760/870			Pull-up Torque	147 LB-FT
Hz	60	Phase	3	Locked-rotor Torque	196 LB-FT
NEMA Design Code	B	KVA Code	H	Starting Current	337 A
Service Factor (S.F.)	1.15			No-load Current	16.2 A
NEMA Nom. Eff.	0	Power Factor	0	Line-line Res. @ 25°C	0.178 Ω
Rating - Duty	40C AMB-CONT			Temp. Rise @ Rated Load	61°C
S.F. Amps				Temp. Rise @ S.F. Load	69°C

Load Characteristics 460 V, 60 Hz, 40 HP

% of Rated Load	25	50	75	100	125	150	S.F.
Power Factor	58	76	83	86	87	87	87
Efficiency	80	87.8	90.3	91.1	91.3	90.8	91.2
Speed	1795	1788	1784	1779	1775	1769	1777
Line amperes	20.6	28.5	37.9	48.2	59.4	71.3	54.9

Performance Graph at 460V, 60Hz, 40.0HP Typical performance - Not guaranteed values

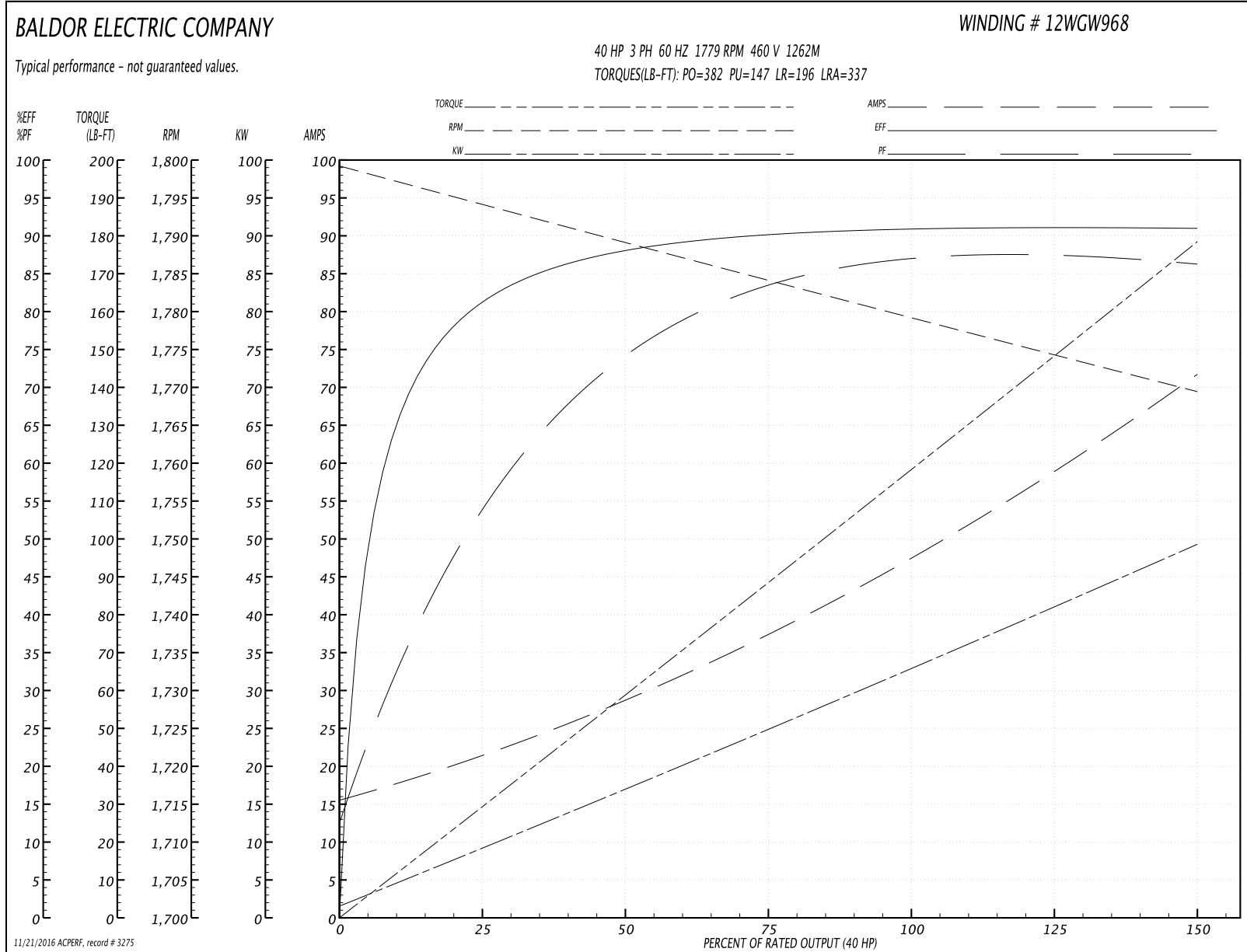

AC Induction Motor Performance Data
Record # 3276 - Typical performance - not guaranteed values

Winding: 12WGW968-R001	Type: 1262M	Enclosure: TEFC
-------------------------------	--------------------	------------------------

Nameplate Data				460 V, 60 Hz: Low Speed Connection	
Rated Output (HP)	40/10			Full Load Torque	60 LB-FT
Volts	460			Start Configuration	direct on line
Full Load Amps	48/18.6			Breakdown Torque	169 LB-FT
R.P.M.	1760/870			Pull-up Torque	61 LB-FT
Hz	60	Phase	3	Locked-rotor Torque	71 LB-FT
NEMA Design Code	B	KVA Code	H	Starting Current	79 A
Service Factor (S.F.)	1.15			No-load Current	12.2 A
NEMA Nom. Eff.	0	Power Factor	0	Line-line Res. @ 25°C	0.682 Ω
Rating - Duty	40C AMB-CONT			Temp. Rise @ Rated Load	37°C
S.F. Amps				Temp. Rise @ S.F. Load	42°C

Load Characteristics 460 V, 60 Hz, 10 HP

% of Rated Load	25	50	75	100	125	150	S.F.
Power Factor	26	40	51	58	63	65	61
Efficiency	72.4	82.8	86.5	87.7	88.1	87.7	87.9
Speed	896	894	891	889	886	882	887
Line amperes	12.9	14.3	16.2	18.6	21.5	24.8	20.34

Performance Graph at 460V, 60Hz, 10.0HP Typical performance - Not guaranteed values

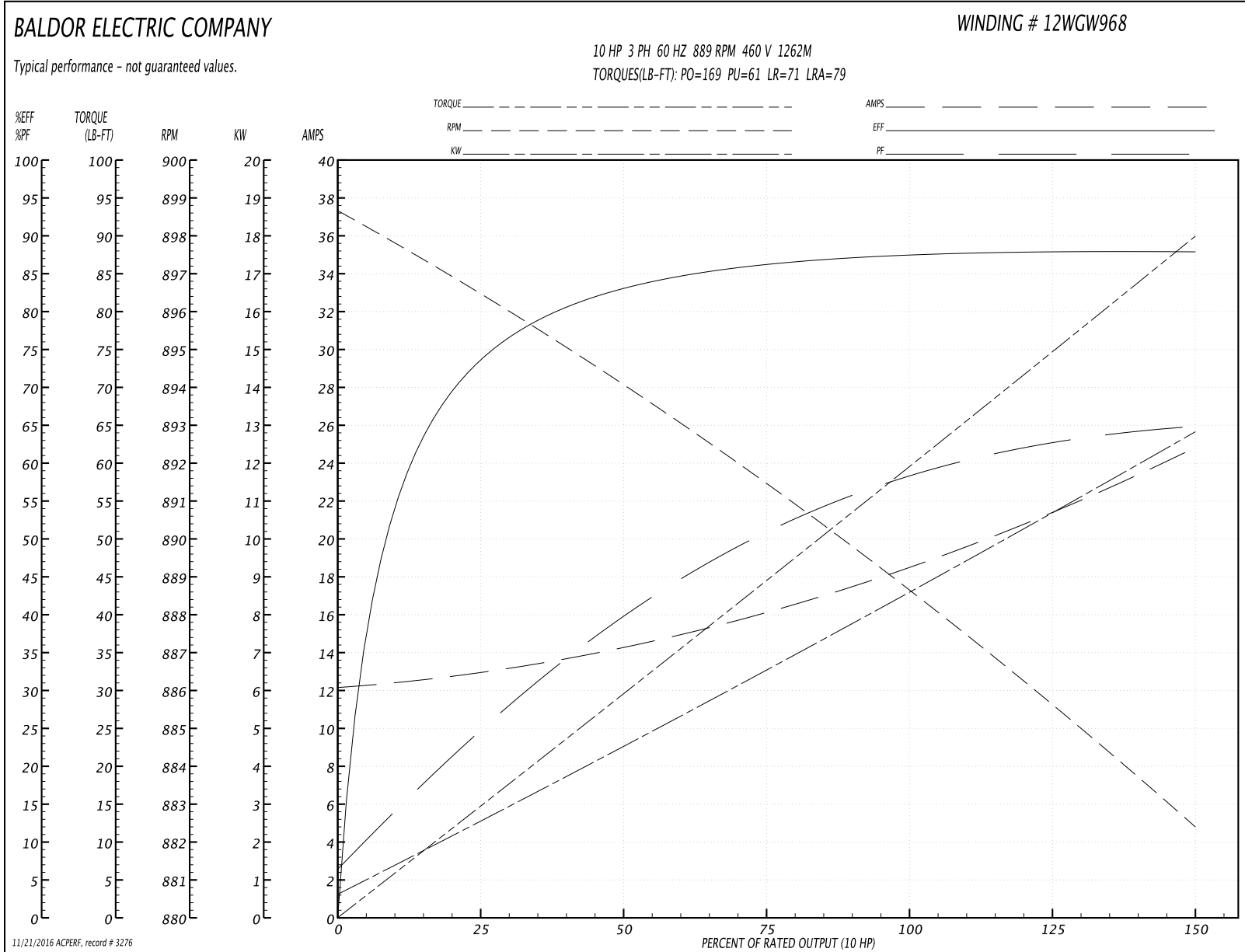

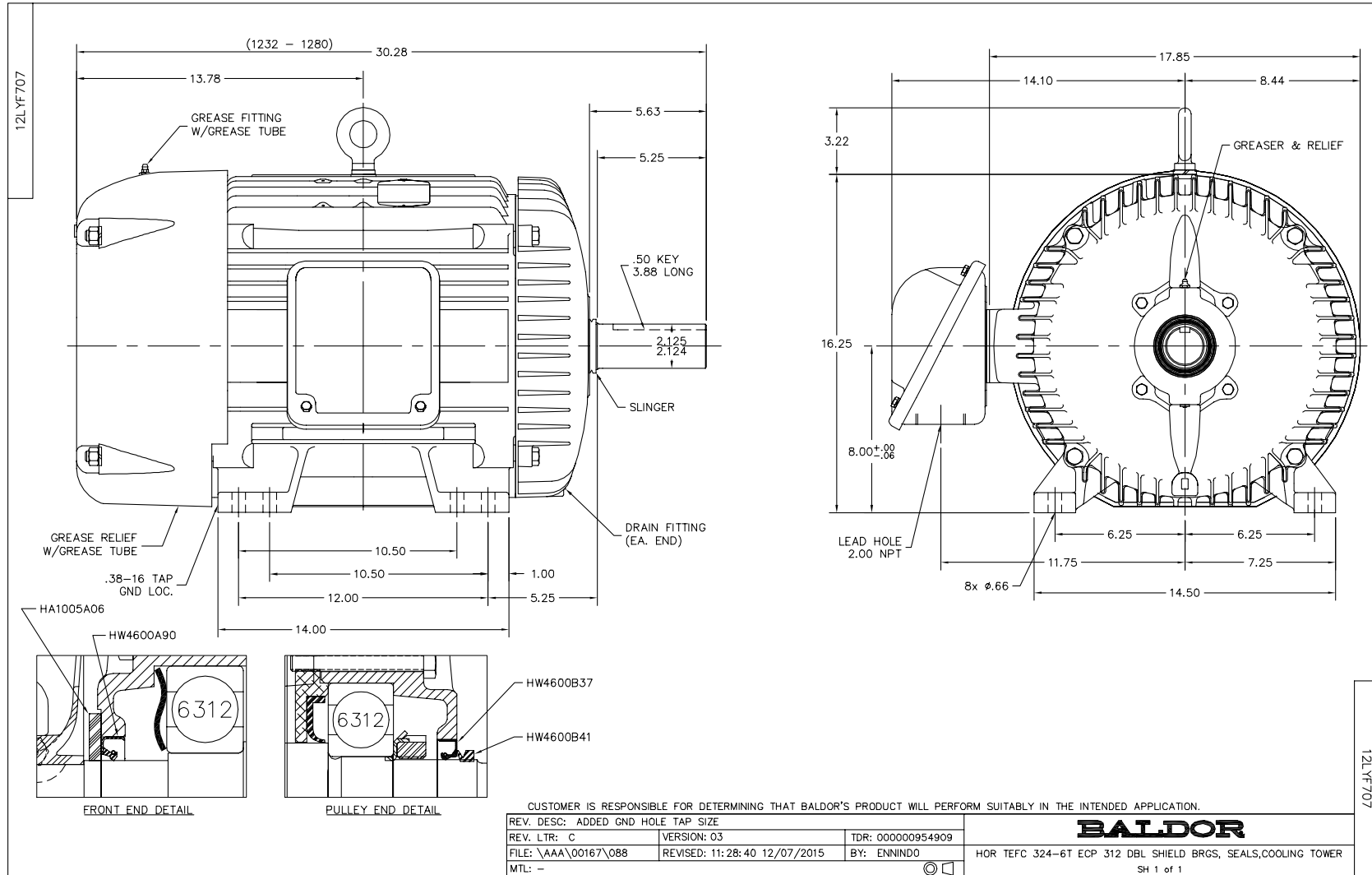

CD0032

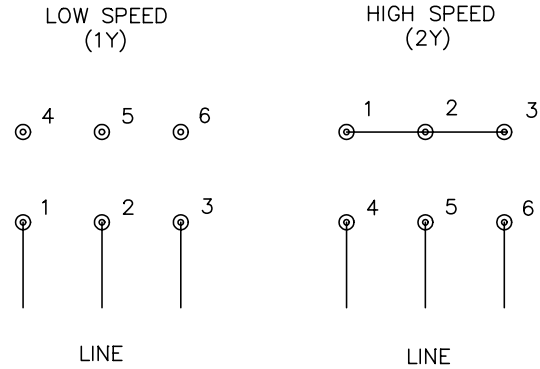

NOTES:

1. INTERCHANGE ANY TWO LINE LEADS TO REVERSE ROTATION.
2. OPTIONAL THERMOSTATS ARE PROVIDED WHEN SPECIFIED.
3. ACTUAL NUMBER OF INTERNAL PARALLEL CIRCUITS MAY BE A MULTIPLE OF THOSE SHOWN ABOVE.
4. LEAD COLORS ARE OPTIONAL. LEADS MUST ALWAYS BE NUMBERED AS SHOWN.

REV. DESC: REVISE TO SHOW OPTIONAL COLORS			
REV. LTR: E	BY: JLP	REVISED: 01/22/99 8:27	TDR: 0171435
CD0032		FILE: AAA00005145	MDL: -
		MTL: -	

BALDOR ELECTRIC Co.

3PH, SV, 6 LEADS, 2-SPEED 1-WINDING VARIABLE TORQUE

CD0032