

# **BALDOR**® • ***RELIANCE***

## **Product Information Packet**

# **VHEM2516T**

**25HP,3525RPM,3PH,60HZ,256HP,0946M,OPEN,F**

Part Detail							
Revision:	B	Status:	PRD/A	Change #:		Proprietary:	No
Type:	AC	Prod. Type:	0946M	Elec. Spec:	09WGY147	CD Diagram:	CD0005
Enclosure:	OPEN	Mfg Plant:		Mech. Spec:	09G625	Layout:	09LYG625
Frame:	256HP	Mounting:	F1	Poles:	02	Created Date:	07-13-2015
Base:	N	Rotation:	R	Insulation:	F	Eff. Date:	05-18-2016
Leads:	9#10					Replaced By:	
Literature:		Elec. Diagram:					

Nameplate NP1259L										
CAT.NO.	VHEM2516T									
SPEC.	09G625Y147G1									
HP	25									
VOLTS	230/460									
AMP	58/29									
RPM	3525									
FRAME	256HP				HZ	60			PH	3
SER.F.	1.15		CODE	J	DES	A		CL	F	
NEMA-NOM-EFF	91.7		PF	88						
RATING	40C AMB-CONT									
CC	010A				USABLE AT 208V			62		
DE	6312				ODE	6208				
ENCL	OPEN		SN							

Parts List		
Part Number	Description	Quantity
SA303804	SA 09G625Y147G1	1.000 EA
RA290945	RA 09G625Y147G1	1.000 EA
S/P107-000-005	SUPER-E PROC'S(254/6 FR.) ZK PLANT - POL	1.000 EA
09CB3002A19	CB MACH - 1.50 N.P.T. LEAD HOLE	1.000 EA
10XN2520K12	1/4-20 X.75 GRD 5	4.000 EA
HW1001A25	LOCKWASHER 1/4, ZINC PLT .493 OD, .255 I	4.000 EA
WD1000B17	T&B CX35TN TERMINAL	1.000 EA
11XW1032G06	10-32 X .38, TAPTITE II, HEX WSHR SLTD U	1.000 EA
09AD2003	AIR DEFLECTOR, 309 OPEN P-BASE	1.000 EA
51XW0832A07	8-32 X .44, TAPTITE II, HEX WSHR SLTD SE	3.000 EA
09EP1203A01P4	FREP, MACH W/FINISH PAINT ONLY	1.000 EA
10XN3816K40	3/8-16 X 2.50 HEX HD CAP SCREW, GRADE 5	2.000 EA
HW1001A38	LOCKWASHER 3/8, ZINC PLT .688 OD, .382 I	2.000 EA
HW5100A08	W3118-035 WVY WSHR (WB)	1.000 EA
10XN2520K36	1/4-20 X 2.25" HX HD SCRWGRADE 5, ZINC P	4.000 EA
HW1001A25	LOCKWASHER 1/4, ZINC PLT .493 OD, .255 I	4.000 EA
HW4600B61	SEAL,V70A FORSH/400700 CR	1.000 EA
10XN3118K68	5/16 18 X 4 1/4 HEX HEAD CAP	4.000 EA
HW1001A31	LOCKWASHER 5/16, ZINC PLT.591 OD, .319 I	4.000 EA
09EP1508A06	ENDPLATE, MACH W/312 BRG	1.000 EA
10XN3816K40	3/8-16 X 2.50 HEX HD CAP SCREW, GRADE 5	4.000 EA
HW1001A38	LOCKWASHER 3/8, ZINC PLT .688 OD, .382 I	4.000 EA
HW4600B41	V-RING SLINGER 2.125 X 2.880 X 0.280	1.000 EA
09FH1502A01	DRIP COVER, MACH	1.000 EA

Parts List (continued)		
Part Number	Description	Quantity
HW3201A11	.38-16 EYEBOLT W/4.00 SHANK	2.000 EA
HW1000A38	WASHER, 3/8" FLAT, SAE Z/P	2.000 EA
HW1001A38	LOCKWASHER 3/8, ZINC PLT .688 OD, .382 I	2.000 EA
09CB3501	CONDUIT BOX LID FOR 09CB3001 & 09CB3002	1.000 EA
51XW2520A12	.25-20 X .75, TAPTITE II, HEX WSHR SLTD	2.000 EA
HW1001A31	LOCKWASHER 5/16, ZINC PLT.591 OD, .319 I	2.000 EA
HW2501E18	KEY, 1/4 SQ X 2.000	1.000 EA
LB1182	WARNING LABEL FOR MOTORS WITH EYENUTS	1.000 EA
HW4500A03	GREASE FITTING, .125 NPT 1610(ALEMITE) 8	1.000 EA
HW4500A17	317400 ALEMITE GREASE RELIEF	1.000 EA
HW4500A20	1/8NPT SL PIPE PLUG	1.000 EA
HA4051A00	PLASTIC CAP FOR GREASE FITTING	1.000 EA
MG1025G05	WILKOFAS, 789.227, MED. GRAY CHAR. MET.	0.200 GA
MJ1000A02	GREASE, POLYREX EM EXXON (USe 4824-15A)	0.080 LB
HW4500A03	GREASE FITTING, .125 NPT 1610(ALEMITE) 8	1.000 EA
HW4500A17	317400 ALEMITE GREASE RELIEF	1.000 EA
HA4051A00	PLASTIC CAP FOR GREASE FITTING	1.000 EA
85XU0407S04	4X1/4 U DRIVE PIN STAINLESS	2.000 EA
LC0005E02	SPL CONN.DIA./WARN.LABEL(LC0005/LB1119)	1.000 EA
NP1259L	ALUM SUPER-E UL CSA-EEV CC NEMA PREMIUM	1.000 EA
42PA1016	PACKAGING GROUP, 09 LARGE FACE	1.000 EA
MN416A01	TAG-INSTAL-MAINT no wire (1200/bx) 11/14	1.000 EA

No performance data has been  
assigned to this product.

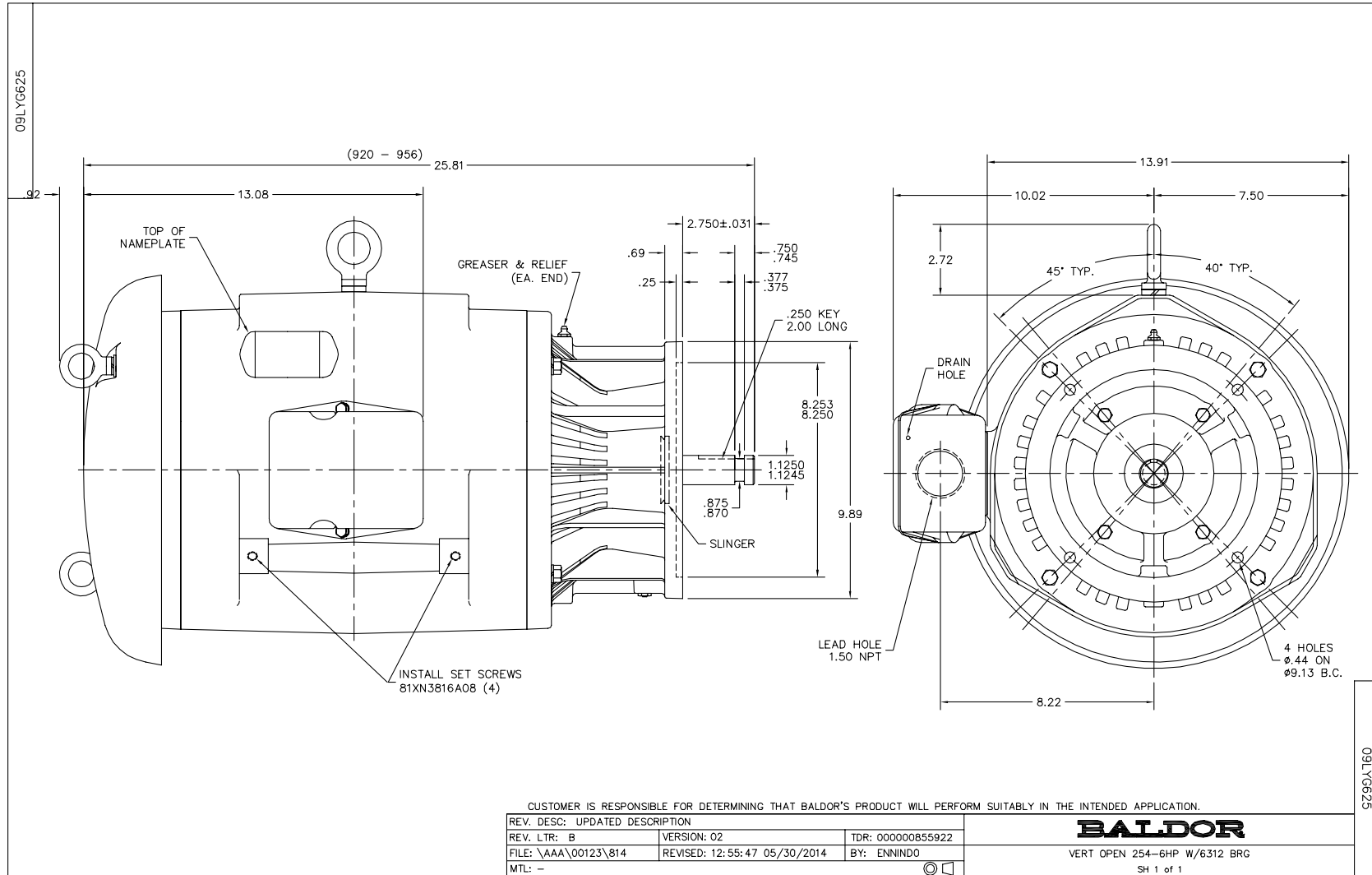

CD0005



LOW VOLTAGE  
(2Y)



LINE

HIGH VOLTAGE  
(1Y)



LINE

NOTES:

1. INTERCHANGE ANY TWO LINE LEADS TO REVERSE ROTATION.
2. OPTIONAL THERMOSTATS ARE PROVIDED WHEN SPECIFIED.
3. ACTUAL NUMBER OF INTERNAL PARALLEL CIRCUITS MAY BE A MULTIPLE OF THOSE SHOWN ABOVE.
4. LEAD COLORS ARE OPTIONAL. LEADS MUST ALWAYS BE NUMBERED AS SHOWN.

REV. DESC: REVISE TO SHOW OPTIONAL COLORS			
REV. LTR: E	BY: JLP	REVISED: 01/19/99 10:15	TDR: 0171435
900000		FILE: AAA00005140	MDL: -
		MTL: -	

**BALDOR ELECTRIC Co.**

3PH, DV, 9 LEADS

CD0005