

Section	SAE Tech Data 4117
Page	1
Date	January 1, 2013
Supersedes 9-1-11	

## Selection For Pumping Application

### *Pump End*

When delivering the required capacity (GPM) to the system piping, the pump must add the amount of Head required by the system at that capacity. The operating head-capacity point should be as close as possible to the highest efficiency line shown on the performance curve, and **MUST** be below the head-capacity line labeled "**Maximum**" **RPM**. The maximum operating RPM for the pump is determined by bearing life, or in some cases, by the pressure limits of the pump. "**The maximum working pressure for NPT tapped and flanged pumps, per ANSI B16.1 class 125, is 175 PSI unless otherwise stated on the pump curve.**"

When used as a booster pump, the pressure at the pump discharge (combination of inlet pressure plus pressure added by the pump) must not exceed the maximum working pressure shown. The Suction NPSHA must be greater than the NPSHR shown on the pump curve.

### *Engine*

The engine used to drive the pump must be suitable for the application. It must produce adequate power for the pump demand, and must rotate in the correct direction (standard rotation is **CLOCKWISE** when viewed from the front of engine).

Internal Combustion Engines are variable speed and variable power machines. The power output depends upon the engine speed (RPM) and will be reduced when operating altitude, and/or the air temperature increases. When driving the pump at the RPM required to deliver water into the system piping, the engine must operate within the engine manufacturers minimum and maximum RPM limits. The power output to supply the pump power demand must not exceed the **CONTINUOUS POWER RATING** of the engine, after derating for all power consuming engine accessories, and

adjustment for installation site altitude and air temperature. Proper power matching of the pump and engine is the responsibility of the pump and engine unit assembler.

## Matching Pump End To Engine

### *S.A.E. Bracket Size*

Type "B" engine drive pumps are available to fit engines having a standard S.A.E. 5 through S.A.E. 1 flywheel housing.

For a new engine, the engine supplier can provide the S.A.E. housing number.

For an existing engine, the flywheel housing bore and bolt circle can be measured and compared against the standard S. A. E. housing dimensions listed in *Table I*, to identify the housing S. A. E. number.

**Table I**

Flywheel Housing Dimensions	S.A.E. Flywheel Housing Size					
	1	2	3	4	5	
<b>A</b>	20-1/8	17-5/8	16-1/8	14-1/4	12-3/8	
<b>B</b>	20-7/8	18-3/8	16-7/8	15	13-1/8	
<b>C</b>	<b>No.</b>	12	12	12	12	8
	<b>Size</b>	7/16-14	3/8-16	3/8-16	3/8-16	3/8-16

**Figure 1**

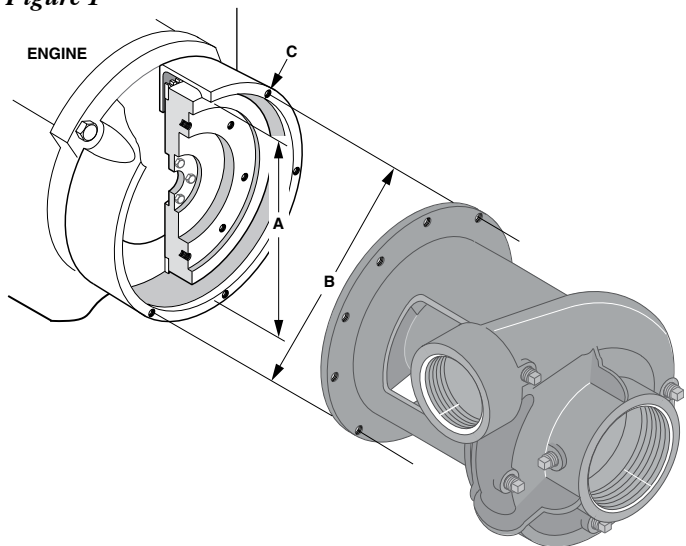

Section	SAE Tech Data 4117
Page	2
Date	January 1, 2013
Supersedes 9-1-11	

- Measure the flywheel housing bore (A), and the bolt circle (B), as accurately as possible with a tape measure (to the nearest 1/32 inch).
- Count the number of threaded holes in the flywheel housing (C). Test the threaded holes with a bolt, to determine the thread series. Unified National Coarse (UNC) cap screws are furnished with the pump end. If the hole threads are other than UNC, the assembler must substitute the correct bolts.
- Compare the measured dimensions (A), (B), and (C) against Table I, to determine the S. A. E. number of the flywheel housing, and select the pump end to fit this housing.
- If the dimensions do not match the S. A. E. standard dimensions in table 1, then the housing is not an S. A. E. standard size. The close-coupled pump end cannot be used with the housing. A frame-mounted pump with a flexible coupling can be used.
- Record measurements on the dimension form on Page 7 in the spaces provided under Flywheel Housing Dimension.

### ***Flywheel Coupling***

The flywheel coupling transmits power from the engine flywheel to the pump shaft. The maximum power that a coupling can safely handle is shown by a rating number, “R”, which is listed in the coupling dimensions tables.

1. When selecting a flywheel coupling for a pump and engine, first determine the power rating that the pump will demand. On the pump performance curve, find the RPM and BHP values required to produce the application head-capacity point.
2. Divide the BHP by the RPM, then multiply the result times 100. The result will be the **demand number** for the pump.

For example, a B6JQBM *can deliver 1500 GPM at 260 feet Total Head when running at 2200 RPM. The power required by the pump will be 120 BHP. The demand number will be:*

$$(120/2200) \times 100 = 5.45$$

3. Next, select a coupling that can safely transmit the power, and which will fit the flywheel dimensions. For a coupling to be suitable, it must have an “R” rating number ***GREATER THAN*** the pump **demand number**. In the above example, the minimum coupling “R” number would be 6.

**NOTE:** The elastomer disk design of Berkeley flywheel couplings provides smooth power flow from the engine to the pump, which minimizes torsional vibration problems.

With the broad range of engines available, a torsional mismatch can occur, which can cause excessive stress in the pump shaft and coupling. Torsional compatibility of the engine, pump, and coupling is the responsibility of the assembler. Berkeley Pumps will supply data for the pump and coupling for use by the assembler for a torsional analysis.

**NOTE:** If the flywheel is fitted with a pilot bearing pressed into a bore at the center, remove it to avoid interference with the pump shaft.

### **Flywheels For Industrial Type Over-Center Clutches**

Figure 2 shows the hollowed-out appearance of the flywheels made for use with over-center type clutch power take-off assemblies.

These flywheels will have a recessed bore machined into the face, and a set of tapped holes, which will be used to attach the coupling to the flywheel.

Dimensions are governed by SAE standard J620d, and are listed in Tables IIA and IIB. The “Clutch Size” shown in the table is the nominal clutch facing diameter for drive ring type over-center clutches.

For a new engine, the engine supplier can furnish the dimensions.

For an existing engine, measure the flywheel dimensions, "D" through "H", using a tape measure and a machinists combination square. Measurements to the nearest 1/32" will usually be adequate.

When dimensions match a standard flywheel coupling listed in Tables IIA or IIB, select the one that has an "R" rating number greater than the pump demand number.

- Record measurements on the dimension form on Page 6 in the spaces provided under Flywheel Dimensions.

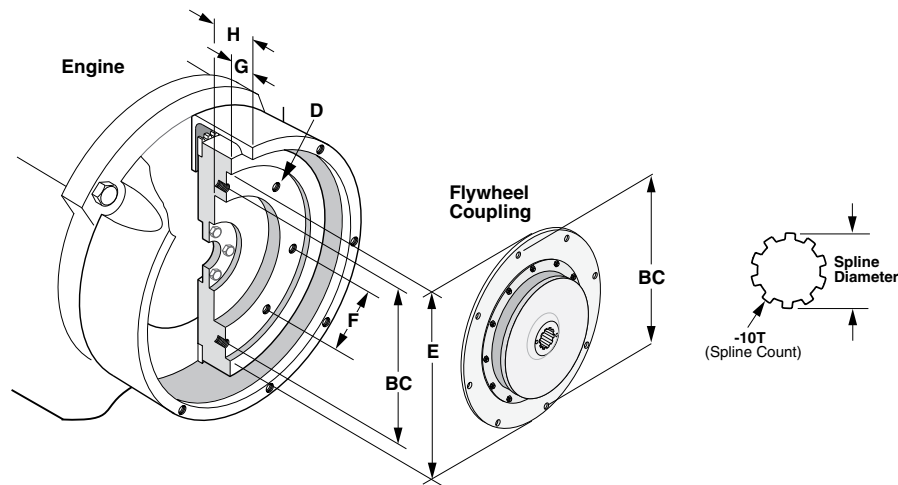

Figure 2

Table IIA – Wide RPM Range, Elastomer Mounted Hub

Clutch Size	Flywheel Dimensions								Flywheel Coupling	
	D		E	BC	F	G	H	R	Catalog Number	Shaft Spline Diameter
	Qty.	Size (UNC)								
6-1/2"	6	5/16-18	8-1/2" OD	7.88	3.94	1.19	1.69	7	B85397	1-3/8" 10T
6-1/2"	6	5/16-18	8-1/2" OD	7.88	3.94	1.19	1.69	7	B85398	1-1/2" 10T
7-1/2"	8	5/16-18	9-1/2" OD	8.75	3.69	1.19	1.69	7	B85399	1-3/8" 10T
7-1/2"	8	5/16-18	9-1/2" OD	8.75	3.69	1.19	1.69	7	B85400	1-1/2" 10T
8"	6	3/8-16	10-3/8" OD	9.62	4.81	2.44	2.94	7	B85401	1-3/8" 10T
8"	6	3/8-16	10-3/8" OD	9.62	4.81	2.44	2.94	7	B85402	1-1/2" 10T
10"	8	3/8-16	12-3/8" OD	11.62	4.47	2.13	2.75	7	B85403	1-3/8" 10T
10"	8	3/8-16	12-3/8" OD	11.62	4.47	2.13	2.75	7	B85404	1-1/2" 10T
11-1/2"	8	3/8-16	13-7/8" OD	13.12	5.06	1.56	2.69	7	B85405	1-3/8" 10T
11-1/2"	8	3/8-16	13-7/8" OD	13.12	5.06	1.56	2.69	7	B85406	1-1/2" 10T

Table IIB – Heavy Duty, Elastomer Mounted Hub

Clutch Size	Flywheel Dimensions								Flywheel Coupling	
	D		E	BC	F	G	H	R	Catalog Number	Shaft Spline Diameter
	Qty.	Size (UNC)								
10"	8	3/8-16	12-3/8" OD	11.62	4.47	2.13	2.75	9	B85407	1-3/8" 10T
10"	8	3/8-16	12-3/8" OD	11.62	4.47	2.13	2.75	9	B85408	1-1/2" 10T
11-1/2"	8	3/8-16	13-7/8" OD	13.12	5.06	1.56	2.69	9	B85409	1-3/8" 10T
11-1/2"	8	3/8-16	13-7/8" OD	13.12	5.06	1.56	2.69	9	B85410	1-1/2" 10T
11-1/2"	8	3/8-16	13-7/8" OD	13.12	5.06	1.56	2.69	16	M15654	2" 10T
11-1/2"	8	3/8-16	13-7/8" OD	13.12	5.06	1.56	2.69	19	M15655	2" 10T
14"	8	1/2-13	18-3/8" OD	17.25	6.63	1.00	2.13	9	B85411	1-1/2" 10T

Section	SAE Tech Data 4117
Page	4
Date	January 1, 2013
Supersedes 9-1-11	

When the measured dimensions match with one of the standard listed couplings, specify the CATALOG NUMBER for the coupling. Note the shaft spline diameter to verify a match with the pump shaft shown in the price list.

- Record measurements on the dimension form on Page 7 in the spaces provided under Flywheel Dimensions.

### Other Flywheels

Some engines are fitted with flywheels especially machined for coupling to other kinds of machinery (electrical generators, torque converters, etc.), and require nonstandard flywheel couplings. If the measured flywheel dimensions do not correspond to dimensions listed in Tables IIa or IIb, write the measured dimensions into the Dimension Form provided on page 7, and send it to Berkeley for quotation of special flywheel coupling.

### Pump To Engine Assembly

#### Preparation For Assembly Of Pump On Engine

- Clean face and register fit of flywheel housing and flywheel as necessary to remove all grease, dirt, or rust (and all traces of rust preventative) which would interfere with installation of pump and/or prevent correct alignment. If flywheel is fitted with a pilot bearing for a transmission shaft, remove and discard. The pilot bearing is not required for installation of the pump end, and could interfere with the pump shaft.
- Examine shaft spline closely. Use a file, if necessary, to remove any burrs that would prevent coupling from sliding freely onto the shaft.
- Lubricate pump shaft spline sparingly with light grease.
- Slide the coupling onto shaft until it is stopped against the shaft.

- Measure the distance from the engine side of flywheel coupling adapter ring to the mounting face of the pump bracket. Refer to Figure 3 below, **Dimension "A"**.
- Next, measure depth from face of flywheel housing on engine, to face on flywheel against which coupling will be bolted. Refer to Figure 3 below, **Dimension "B"**.

**NOTE:** When the coupling is correctly assembled, the hub will not bottom out on the shaft splines. If it should bottom out, reverse the coupling on the shaft as shown to gain clearance.

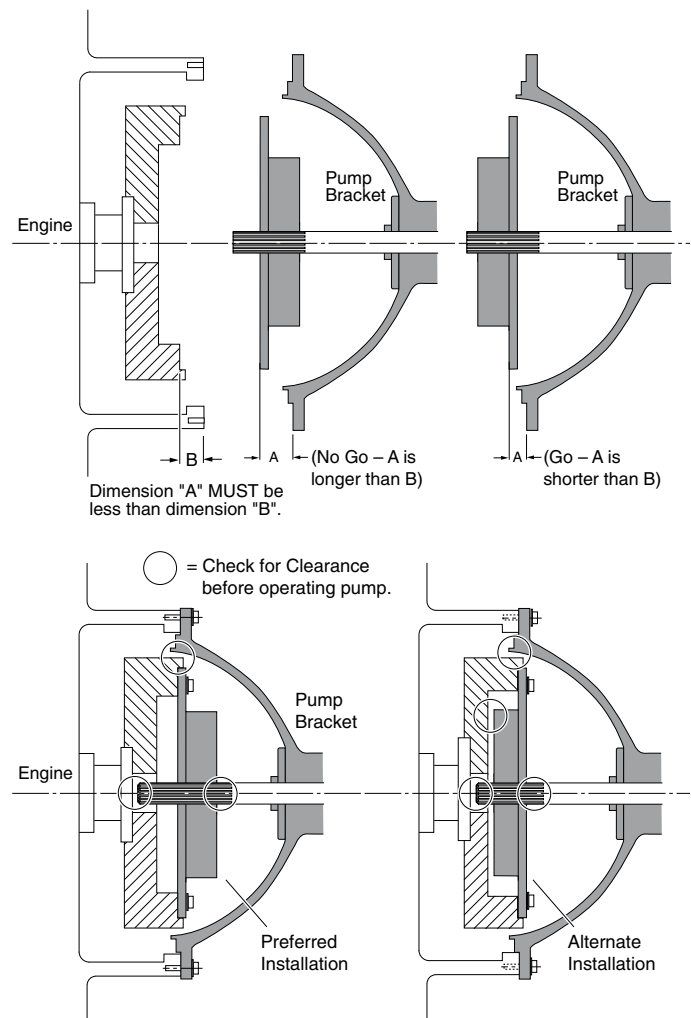

**Figure 3**

Pump measurement must be less than engine measurement or axial interference will result in thrust force on engine crank shaft bearings. Simply stated, **Dimension “A” must be less than Dimension “B”**.

### **Installation Of Coupling On Flywheel**

#### ***Flywheel Coupling Over-Center Type:***

These couplings are aligned concentrically with the flywheel by register fit on the flywheel.

Fit the coupling into the flywheel. Align the bolt holes and engage coupling with register fit on flywheel. Tap coupling with a soft heavy hammer, if necessary, to be sure that it is seated flat against flywheel. Secure coupling tightly to flywheel with cap-screws and lock washer.

### **Installation Of Pump On Engine**

- Lift pump with suitable lifting apparatus and align pump shaft with coupling. End of pump shaft has a pilot diameter which permits easy engagement of pump shaft into coupling.
- Reach into pump suction opening and rotate impeller slightly until the splines on the shaft will engage the coupling. Verify that there is no gap between bracket and flywheel housing faces. Rotate pump as necessary to align bracket holes with engine. Install cap screws and bolt pump end securely to engine.

**NOTE: If any interference, or incompatibility of parts is detected during installation, DO NOT proceed with assembly. Direct the problem to your nearest Berkeley Professional Dealer.**

### **Specifying The Pump End**

When a pump model with required performance has been selected, refer to the price list and locate a catalog number for that pump end. Make sure the bracket size matches the engine S. A. E. housing size.

Choose a flywheel coupling to fit the flywheel dimensions. If more than one coupling is offered for the flywheel, choose the one having an “R” number greater than the demand number for the pump.

## Dimensions Form

Measured Dimensions For:	
Job name <input style="width: 90%;" type="text"/>	Order Number <input style="width: 90%;" type="text"/>
Engine Manufacturer <input style="width: 90%;" type="text"/>	Model <input style="width: 90%;" type="text"/>
For Pump Model <input style="width: 90%;" type="text"/>	HP Req'd <input style="width: 90%;" type="text"/> At <input style="width: 90%;" type="text"/> RPM
Flywheel Housing Dimensions (From page 5)	
"A"= <input style="width: 80%;" type="text"/> In.	"B"= <input style="width: 80%;" type="text"/> In.
Hole "C"= Qty: <input style="width: 40%;" type="text"/> Size: <input style="width: 40%;" type="text"/>	
From Table I, Page 5 , SAE Housing Size is: <input style="width: 40%;" type="text"/>	
Flywheel Dimensions (From page 7)	
Hole "C" Qty: <input style="width: 40%;" type="text"/> Size: <input style="width: 40%;" type="text"/> Dim. "BC"= <input style="width: 40%;" type="text"/> In.	
"E"= <input style="width: 40%;" type="text"/> In.	"F"= <input style="width: 40%;" type="text"/> In.
"G"= <input style="width: 40%;" type="text"/> In.	"H"= <input style="width: 40%;" type="text"/> In.
If all even except one, center to center of odd hole is <input style="width: 40%;" type="text"/> In.	
For Fig. 4 symmetrically grouped set of holes: "F1"= <input style="width: 40%;" type="text"/> In.	
"F2"= <input style="width: 40%;" type="text"/> In.	
<b>"Standard" Flywheel Coupling from Table IIA or IIB:</b> (From page 3 or 4)	
<input style="width: 80%;" type="text"/>	

**Type “B” Centrifugal Pumps**  
**Close coupled pump ends**  
**SAE Engine Mount**

Section	SAE Tech Data 4117
Page	7
Date	January 1, 2013
Supersedes 9-1-11	

### Limited Warranty

BERKELEY warrants to the original consumer purchaser (“Purchaser” or “You”) of the products listed below, that they will be free from defects in material and workmanship for the Warranty Period shown below.

Product	Warranty Period
<b>Water Systems:</b>	
Water Systems Products — jet pumps, small centrifugal pumps, submersible pumps and related accessories	<i>whichever occurs first:</i> 12 months from date of original installation, or 18 months from date of manufacture
Pro-Source™ Composite Tanks	5 years from date of original installation
Pro-Source™ Steel Pressure Tanks	5 years from date of original installation
Pro-Source™ Epoxy-Lined Tanks	3 years from date of original installation
Sump/Sewage/Effluent Products	12 months from date of original installation, or 18 months from date of manufacture
<b>Agricultural/Commercial:</b>	
Centrifugals – close-coupled motor drive, frame mount, SAE mount, engine drive, VMS, SSCX, SSHM, solids handling, submersible solids handling	12 months from date of original installation, or 24 months from date of manufacture
Submersible Turbines, 6” diameter and larger	12 months from date of original installation, or 24 months from date of manufacture

Our limited warranty will not apply to any product that, in our sole judgement, has been subject to negligence, misapplication, improper installation, or improper maintenance. Without limiting the foregoing, operating a three phase motor with single phase power through a phase converter will void the warranty. Note also that three phase motors must be protected by three-leg, ambient compensated, extra-quick trip overload relays of the recommended size or the warranty is void.

Your only remedy, and BERKELEY’s only duty, is that BERKELEY repair or replace defective products (at BERKELEY’s choice). You must pay all labor and shipping charges associated with this warranty and must request warranty service through the installing dealer as soon as a problem is discovered. No request for service will be accepted if received after the Warranty Period has expired. This warranty is not transferable.

BERKELEY SHALL NOT BE LIABLE FOR ANY CONSEQUENTIAL, INCIDENTAL, OR CONTINGENT DAMAGES WHATSOEVER. THE FOREGOING LIMITED WARRANTIES ARE EXCLUSIVE AND IN LIEU OF ALL OTHER EXPRESS AND IMPLIED WARRANTIES, INCLUDING BUT NOT LIMITED TO IMPLIED WARRANTIES OF MERCHANTABILITY AND FITNESS FOR A PARTICULAR PURPOSE. THE FOREGOING LIMITED WARRANTIES SHALL NOT EXTEND BEYOND THE DURATION PROVIDED HEREIN.

Some states do not allow the exclusion or limitation of incidental or consequential damages or limitations on the duration of an implied warranty, so the above limitations or exclusions may not apply to You. This warranty gives You specific legal rights and You may also have other rights which vary from state to state.

This Limited Warranty is effective June 1, 2011 and replaces all undated warranties and warranties dated before June 1, 2011.

**In the U.S.: BERKELEY, 293 Wright St., Delavan, WI 53115**  
**In Canada: 269 Trillium Dr., Kitchener, Ontario N2G 4W5**