

**BERKELEY®**

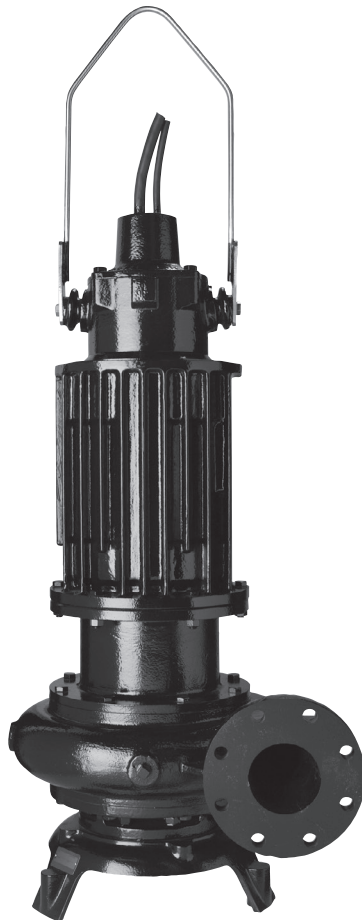

**4BSW4 Series**

## PUMP/MOTOR IDENTIFICATION

Carefully record all of the following data from your pump/motor nameplate. It will aid in obtaining the correct replacement parts for your pump. In addition to the nameplate, the pump serial number is also stamped on the discharge flange.

### Pump:

Serial Number \_\_\_\_\_

Size \_\_\_\_\_ Model # \_\_\_\_\_

GPM \_\_\_\_\_ Head \_\_\_\_\_ (feet)

BHP: \_\_\_\_\_ RPM: \_\_\_\_\_

Pump \_\_\_\_\_ Weight (lbs.) \_\_\_\_\_

### Motor:

Horsepower \_\_\_\_\_

Serial Number \_\_\_\_\_

Motor Frame \_\_\_\_\_

Full Load Speed \_\_\_\_\_

Full Load Amps \_\_\_\_\_

Phase/Hz/Volts \_\_\_\_\_ / \_\_\_\_\_ / \_\_\_\_\_

Motor Weight \_\_\_\_\_

Motor Identification Number \_\_\_\_\_

Date Placed in Service \_\_\_\_\_

# TABLE OF CONTENTS

<b>PUMP/MOTOR IDENTIFICATION</b> .....	<b>2</b>
<b>INTRODUCTION</b> .....	<b>3</b>
<b>WARRANTY</b> .....	<b>4</b>
<b>PRESTART-UP AND START-UP CHECKLIST</b> .....	<b>5</b>
<b>SAFETY INSTRUCTIONS</b> .....	<b>6</b>
<b>STORAGE OF PUMPS</b> .....	<b>6</b>
<b>GENERAL</b> .....	<b>6</b>
<b>INSTALLATION</b> .....	<b>7</b>
<b>OPERATION</b> .....	<b>8</b>
<b>TROUBLESHOOTING</b> .....	<b>10</b>
<b>MAINTENANCE</b> .....	<b>11</b>
<b>ILLUSTRATIONS</b> .....	<b>13</b>

---

## INTRODUCTION

Congratulations! You are the new owner of the finest pump commercially available. If you give it the proper care as outlined and recommended by this manual, it will provide you with reliable service and long life.

**NOTE:** Read this complete manual and manuals for all component equipment before assembly or installation is started. It contains information which is the result of engineering and research efforts. It is designed to supply adequate instructions for the installation, operation and maintenance of your pump. Failure or neglect to properly install, operate or maintain your pump may result in personal injury, property damage or unnecessary damage to the pump.

This manual applies to the pump installation, operation and maintenance. They are intended to be general and not specific. If your operating conditions ever change, always refer to the factory for reapplication. Always refer to the manuals provided by manufacturers of the accessory equipment for their separate instructions.

This manual contains installation, operation and maintenance instructions for Berkeley UL and CSA Listed submersible pumps and motors. Instructions for non-UL or non-CSA listed submersible pumps and motors may be obtained by contacting the factory.

Variations exist in both the equipment used with these pumps and in the particular installation of the pump and driver. Therefore, specific operating instructions are not within the scope of this manual. The manual contains general rules for installation, operation and maintenance of the pump. If there are questions regarding the pump or its application which are not covered in this manual, please contact the factory as follows:

**Berkeley**  
**293 Wright Street**  
**Delavan, WI 53115**

To obtain additional data on hydraulics and pump selection and operation, we suggest you purchase "Hydraulic Institute Standards" from the Hydraulic Institute, 9 Sylvan Way, Parsippany, NJ 07054-3802.

### **California Proposition 65 Warning**

**▲ WARNING** This product and related accessories contain chemicals known to the State of California to cause cancer, birth defects or other reproductive harm.

## Limited Warranty

BERKELEY warrants to the original consumer purchaser ("Purchaser" or "You") of the products listed below, that they will be free from defects in material and workmanship for the Warranty Period shown below.

Product	Warranty Period
<b>Water Systems:</b>	
Water Systems Products — jet pumps, small centrifugal pumps, submersible pumps and related accessories	<i>whichever occurs first:</i> 12 months from date of original installation, or 18 months from date of manufacture
Pro-Source™ Composite Tanks	5 years from date of original installation
Pro-Source™ Steel Pressure Tanks	5 years from date of original installation
Pro-Source™ Epoxy-Lined Tanks	3 years from date of original installation
Sump/Sewage/Effluent Products	12 months from date of original installation, or 18 months from date of manufacture
<b>Agricultural/Commercial:</b>	
Centrifugals – close-coupled motor drive, frame mount, SAE mount, engine drive, VMS, SSCX, SSHM, solids handling, submersible solids handling	12 months from date of original installation, or 24 months from date of manufacture
Submersible Turbines, 6" diameter and larger	12 months from date of original installation, or 24 months from date of manufacture

Our limited warranty will not apply to any product that, in our sole judgement, has been subject to negligence, misapplication, improper installation, or improper maintenance. Without limiting the foregoing, operating a three phase motor with single phase power through a phase converter will void the warranty. Note also that three phase motors must be protected by three-leg, ambient compensated, extra-quick trip overload relays of the recommended size or the warranty is void.

Your only remedy, and BERKELEY's only duty, is that BERKELEY repair or replace defective products (at BERKELEY's choice). You must pay all labor and shipping charges associated with this warranty and must request warranty service through the installing dealer as soon as a problem is discovered. No request for service will be accepted if received after the Warranty Period has expired. This warranty is not transferable.

BERKELEY SHALL NOT BE LIABLE FOR ANY CONSEQUENTIAL, INCIDENTAL, OR CONTINGENT DAMAGES WHATSOEVER. THE FOREGOING LIMITED WARRANTIES ARE EXCLUSIVE AND IN LIEU OF ALL OTHER EXPRESS AND IMPLIED WARRANTIES, INCLUDING BUT NOT LIMITED TO IMPLIED WARRANTIES OF MERCHANTABILITY AND FITNESS FOR A PARTICULAR PURPOSE. THE FOREGOING LIMITED WARRANTIES SHALL NOT EXTEND BEYOND THE DURATION PROVIDED HEREIN.

Some states do not allow the exclusion or limitation of incidental or consequential damages or limitations on the duration of an implied warranty, so the above limitations or exclusions may not apply to You. This warranty gives You specific legal rights and You may also have other rights which vary from state to state.

This Limited Warranty is effective June 1, 2011 and replaces all undated warranties and warranties dated before June 1, 2011.

**In the U.S.: BERKELEY, 293 Wright St., Delavan, WI 53115**  
**In Canada: 269 Trillium Dr., Kitchener, Ontario N2G 4W5**

## SUBMERSIBLE PUMP/MOTOR PRESTART-UP AND START-UP CHECKLIST

Contractor \_\_\_\_\_ Pump Serial Number \_\_\_\_\_

Project Name \_\_\_\_\_ Pump Model Number \_\_\_\_\_

Date of Shipment \_\_\_\_\_ Motor Serial Number \_\_\_\_\_

Procedure	Yes	No	N/A	Comments
<b>1. Shipment</b>				
Was there any damage in transit? (If so, has freight claim been filed?)				_____
Were all items received?				_____
<b>2. Storage</b>				
Has equipment been protected from the elements?				_____
Was equipment subject to flooding?				_____
<b>3. Installation</b>				
Have proper anchor bolts been used?				_____
Have the bolts been properly tightened?				_____
Has discharge been checked for pipe strain?				_____
<b>4. Rotation</b>				
Has the rotation of the drives been checked for correct rotation?				_____
Are moisture detectors wired into controls?				_____
Are thermostats wired into controls?				_____
Is motor wired to a continuous megging device?				_____
Do controls have proper disconnect protection?				_____
Are heater coils correctly sized and installed properly?				_____
Are controls wired with an alarm that will promptly notify personnel if a problem develops?				_____
<b>5. System</b>				
Has the system been checked to insure that it is free of foreign matter which could be damaging to the pump?				_____
Is liquid available to the pump?				_____
Has assurance been obtained from responsible parties that all piping is secure and that the routing of flow has been established and is correct?				_____
Are liquid levels properly set?				_____
<b>6. Start-Up</b>				
Has flow been established? Flow rate: _____ GPM				_____
Have gauge readings been taken? Discharge pressure: _____ PSI				_____
Is excessive vibration present?				_____
What is recorded line voltage? _____ volts				_____
What is motor amp draw on each leg? 1.) _____ 2.) _____ 3.) _____				_____
<b>7. Safety</b>				
Have all safety labels been read and understood?				_____

Name \_\_\_\_\_ Date \_\_\_\_\_

Name \_\_\_\_\_ Date \_\_\_\_\_

## READ AND FOLLOW SAFETY INSTRUCTIONS!

 This is the safety alert symbol. When you see this symbol on your pump or in this manual, look for one of the following signal words and be alert to the potential for personal injury.

**▲ DANGER** warns about hazards that will cause serious personal injury, death or major property damage if ignored.

**▲ WARNING** warns about hazards that will or can cause serious personal injury, death or major property damage if ignored.

**▲ CAUTION** warns about hazards that will or can cause minor personal injury or property damage if ignored.

The label **NOTE** indicates special instructions which are important but not related to hazards.

The installation, use and operation of this type of equipment is affected by various Federal, State and Local Laws, Underwriters Laboratories (UL) and the regulations concerning OSHA. Compliance with such laws relating to the proper installation and safe operation of this type of equipment is the responsibility of the equipment Owner and all necessary steps should be taken by the Owner to assure compliance with such laws before operating the equipment.

The Motor supplied on this order is UL and CSA Listed for Hazardous Locations Class 1, Division 1, Group C and D, when used with normal line current. When the motor is built with inverter duty insulation, the pump may be used in variable frequency drive applications.

**▲ WARNING** **Risk of serious eye injury from flying chips, foreign matter on the pump, etc.** Wear protective eye glasses while working on this equipment.

**▲ WARNING** **Risk of sudden and unexpected starts. Disconnect and lock out power and verify that pump cannot start before servicing or working on equipment.** Many installations use automatic starting equipment, which can cause the unit to start at any time without warning. Proper precautions should be taken to avoid injury as a result of automatic starting of the equipment.

**NOTE:** This product has been designed specifically for operation in water or sewage. Consult the factory before using it with other liquids.

**▲ WARNING** **Risk of puncture wounds and health hazards from sharp objects. Do not try to clean the pump with bare hands.** Always wear heavy puncture resistant gloves when cleaning the pump. The pumped material may contain items that may present health hazards such as needles and other sharp objects.

**Before attempting to service this pump:**

1. **Familiarize yourself with this manual.**
2. **Disconnect or lock out the power source to insure the pump will not start. Confirm power source disconnect with appropriate electrical test equipment.**
3. **Close the discharge valve, and if present, the suction valve.**

**After the pump has been installed, make certain that the pump and all piping connections are tight and are**

**properly supported prior to start-up and operation.**

**▲ WARNING** **Burn hazard.** Certain procedures in disassembly and assembly require parts be heated to high temperatures. Heated parts can cause severe burns. Wear heat resistant gloves when handling heated parts.

**NOTE:** This manual contains general instructions for installation and operation of Explosion-Proof Submersible Pumps. Since pumping station designs and electrical controls will vary significantly between various installations, only general wiring diagrams for the motor and controls are shown in this manual.

## STORAGE OF PUMPS

**NOTE:** If the equipment is not to be immediately installed and operated, at least do the following:

Consider a unit in storage when:

1. It has been delivered to the jobsite and is awaiting installation.
2. It has been installed but operation is delayed.
3. There are long (30 days or more) periods between operation cycles.
4. The facility is shut down.

**NOTE:** Improper storage could result in product failures or damage not covered by warranty.

If the pumps and motors are not immediately installed and operated, store them vertically in a clean, dry, well-ventilated area, free from vibration, moisture, and rapid or wide variations in temperature. Rotate the motor shaft by hand several revolutions every 4 weeks to ensure the bearing and seal components are coated with oil for protection against corrosion.

**NOTE:** Keep ends of power and control cables clean and dry; do not submerge in water or sewage. Submergence will result in permanent damage to the cables.

## GENERAL

The Model 4BSW4 pumps consist of several components. The following is a list of those major parts (or component assemblies) and a brief description of their design and function.

### Impellers

The impeller is a balanced solids-handling type made of close-grained cast iron. The impeller is a one piece, single suction, enclosed radial flow design with well-rounded leading vanes and then tapered toward the trailing edge for a circular flow pattern. The waterways through the impeller have extremely smooth contours, devoid of sharp corners, so as to minimize rags, stringy or fibrous material from catching or clogging. The impeller is balanced and secured to the shaft by means of a bolt and key. The arrangement is such that the impeller cannot be loosened from torque in either forward or reverse rotation.

### Volute

The volute is matched to the impeller and made of close-grained cast iron. The volute is of one-piece constant velocity, equalizing pressure design with smooth fluid passage large enough to pass any size solid that can pass through the impeller. The volute includes a flanged discharge connection.

## Fits and Hardware

The volute and fronthead are manufactured with concentric shoulder fits to assure accurate alignment. All bolts, nuts and capscrews are stainless steel and are of the hex-headed type.

## Motor

The motors have a rated maximum operating skin temperature of 160 degrees C.

Motors are designed for standard use with either 230V or 460V three phase service depending on the nameplate rating. On special order other voltages are available. All motor ratings are noted on the motor nameplate, and are based on operating in a 40 degree C ambient temperature. Insulation is Class F as noted on the motor nameplate.

The standard motors have duty ratings for any one of three operating conditions: continuous duty in air, continuous duty submerged, and one-hour duty in air. For a more detailed discussion of these conditions, see the section on "Operation."

The motor is mounted directly on the pump volute, and the pump impeller is installed on the motor shaft. All motor housing joints are equipped with long rabbet fits and O-ring seals. The housing is made of close grain cast iron. The motor shaft and all external nuts and bolts are stainless steel.

Motors have a single row, upper radial ball bearing and a single row, lower thrust ball bearing. All bearings are oil lubricated for life.

The motor shaft is sealed with two mechanical seals, mounted in a tandem arrangement, and with an oil chamber between them. The inner seal has a carbon rotating face and a ceramic stationary face (optional seal faces are available for the inner seal). The outer seal has a reaction bonded silicone carbide stationary face and a tungsten carbide rotating face. The o-rings for both the inner seal and outer seal stationary faces are viton.

**Since all mechanical seals must seep moisture to provide lubrication to the sealing faces, two moisture detector probes have been installed in the seal chamber. This system monitors the quantity of water in the oil chamber. When a mixture of 25 to 30% of water to oil is reached, the moisture controller will signal that it is time to change the oil. O-ring sealed fill and drain plugs are included for ease of changing oil in the oil chamber.**

Thermostats in the motor windings are standard, and protect the motor from excessive winding temperatures. Power and control cables are epoxy-potted into the cover to prevent moisture from intruding into the motor. For additional protection of maintenance and operation personnel, it is highly recommended that the motor power circuitry have ground fault circuit interruption (GFCI) capabilities.

**Non-Clog:** Pumps referred to as non-clog are specially designed to accommodate the pumping of solids by providing larger than normal passage ways through the impeller and volute, minimizing the number of impeller vanes and volute cut-waters. In addition, the leading edges of the impeller vanes and the volute cutwater are well rounded to promote the shedding of long fibrous material. These features make non-clog pumps more resistant to plugging from the accumulation of solids in the pump than a pump of conventional design. However, no pump can ever be described as being completely resistant to clogging.

When the content of the pumpage includes large amounts of fibrous solids which cannot be removed prior to the pump, the sump design should be of the nature to allow the pumps to be run at near full speed, drawing down the sump and cycling the pumps on and off as required. This is particularly true during low flow periods when solids tend to settle out and accumulate at the bottom of the sump and in the suction piping. Low speed and low velocity pumping can even cause plugging in a vertical leg of the discharge piping. Reduced pump speed and low suction velocities must be avoided to reduce the tendency to clog. The sump and suction piping design should be of the "self-cleaning" design to avoid the accumulation of solids at these locations.

## INSTALLATION

### General

Carefully read all sections of this manual and all other instruction manuals supplied by manufacturers of other equipment supplied with this pump.

Upon receipt of this shipment, unpack and inspect the pump/driver assembly and individual parts to ensure none are missing or damaged. Carefully inspect all boxes and packing material for loose parts before discarding them. Report immediately to the factory, and the transportation company involved, any missing parts or damage incurred during shipment, and file your "damaged and/or lost in shipment" claim with the carrier immediately.

### Piping

**NOTE:** All piping connections must be made with the pipe in a rigid supported state, and without the need to apply vertical or side pressure to obtain alignment of the piping with pump flange.

All piping should be independently supported so that neither mechanical nor hydraulic pipe strain exists.

### Discharge Piping

Discharge pipe should be as direct as possible with a minimum of valves to reduce pipe friction losses. A check valve and closing valve should be installed in the discharge line. The check valve, between the pump and closing valve, prevents reverse rotation in the event of power failure. The closing valves are used to isolate the pump for repairs.

**▲ WARNING** **Crushing hazard if pump falls. Pump is heavy (5 and 7.5 HP: 625 lbs.; 10 and 15 HP = 660 lbs.); use appropriate lifting gear. Never stand under a hanging load.**

A. Attach one end of a suitable lifting cable or chain to the metal motor bale or lifting harness. Attach the other end to a suitable lift or hoist that will bear the weight of the pump.

**NOTE the following:** Prior to lifting the unit, check to make sure that all hooks, cables, chains and hoists are of adequate strength and size. The approximate weight of pump plus motor is 625–660 pounds.

Lifting mechanism sheave shall have a diameter large enough so as to not crimp or severely bend the lifting cable. Small diameter or angle type sheaves could cause cable failure.

Do not lift by the power or control cable. Damage to the cables and connections will result and you may drop the pump.

B. With an adequate hoist, lower the pump into the wet pit.

- C. Connect the discharge piping. Tighten all bolts and eliminate any pipe strain.
- D. Install the controls per the control manufacturer's recommendations.
- E. Wire the motor and motor protection devices.  
The motors are supplied with one 4-lead power cable. Lead color codes and terminal connections are outlined in Tables 1 and 2.

**Table 1: Power Cable Terminal Connections (1)**

Lead Color Code				
Frame	Black	White	Red	Green
210	T3	T1	T2	Ground

**Table 2: Control Cable Terminal Connections (2)**

Control Device	Lead Color Code				
	Black	White	Red	Orng	Grn
Thermostats	P2	P1	N/A	N/A	
Moisture Detector	N/A	N/A	W2	W1	Grd

- (1) Power leads connect the motor to the power supply.
- (2) Control leads connect thermostats, moisture detectors and optional thrust bearing RTD controls.

**⚠ WARNING Possible explosion hazard. UL requirements do not permit splicing the cable.** Make all connections at the terminal ends of the cable.

Figure 4 (later in this manual) shows the simplified schematic wiring diagram for 210 frame motors. The thermostats should be wired in series with the stop button. Provision for manual reset of the motor after the thermostats trip is recommended. The thermostats themselves will reset automatically after the motor windings cool down.

**⚠ WARNING Risk of explosion.** All electric controls and motor starting equipment must be located outside the hazardous area unless they are approved for hazardous locations.

**⚠ WARNING Hazardous voltage and risk of unexpected motor starts. Can burn or kill.** Open and lock out the disconnect switch before doing any work on the motor-pump unit.

The current through the thermostat shall not exceed the

**Table 3: Thermostat Current Limits**

Volts	Continuous Amps	Inrush Amps
220-240	1.5	15.0
440-480	0.75	7.5

limits in the following table:

**NOTE:** Thermostats must be connected in the circuit and must be operative. Running the motor with inoperative thermostats will void the warranty. Thermostat contact rating 120-600 VAC, 360 VA maximum.

Figure 4 (later in this manual) shows a typical wiring diagram for the moisture detectors for cable lengths

of 125 feet or less. The detectors can be wired to shutdown the motor or to activate an indicator or alarm device, or to do both. (Sample moisture detection controllers are located in the drawing section of this manual.) A compatible controller must be connected to properly protect the motor. A controller rated for 500 volts A/C with a triggering resistance across the probes of 25,000 Ohms is required.

**NOTE:** Moisture detectors must be connected and functional. Operation of the pump without operative moisture detectors will void the motor warranty.

- F. The direction of rotation should be checked before the pump is put in operation. Raise the pump back out of the wet-well and carefully lay it horizontally. The correct rotation of the pump is indicated by an arrow cast on the volute. While looking into the pump section, "bump" start the motor to observe rotation.

**⚠ DANGER Risk of loss of fingers or serious hand injury. Do not put hands or any item in the volute suction** to determine direction of rotation, as doing so will cause serious personal injury.

Bump start is generally accomplished on three-phase motors by engaging and immediately disengaging the power switch. It is seldom necessary to engage the power source for more than one second to determine motor rotation.

Note the direction of impeller rotation. If the impeller rotates opposite the arrow on the pump volute, reverse any two of the three power leads and motor rotation will be reversed.

Both motor mechanical seals are lubricated and cooled by the oil in the oil chamber. Oil chamber is filled at the factory prior to shipment.

## OPERATION

### General

**NOTE:** This section contains general rules for operation. Because variations may exist in a particular installation between the pumps, the drivers and the accessory equipment, specific operating instructions are not within the scope of this manual.

**⚠ WARNING Hazardous voltage. Can shock, burn, or kill.** Before starting or operating the pump, read this entire manual and the control manufacturer's instructions for proper operation of the system, especially complying with the following instructions:

1. Duty Cycles:

It is important that the motor be operated within the limits of its rating. Carefully note the "Duty" block on the motor nameplate.

A Duty cycle of "Short Time in Air 1 Hour" requires the following:

The capacity of the pump should be selected to be greater than the maximum flow into the wet well. Under maximum flow conditions, the pump should draw down the sump from the top of the motor, Level A, to the bottom flange on the motor, Level B, within 1 hour. See Figure 1.

The power frequency shall not vary by more than +/-5%,

and the voltage by more than +/-10% of the nameplate data. Voltage deviation from the nameplate ratings will have an effect on the pump speed and, therefore, on pump performance. The pump will deliver the rated head and capacity only when running at the rated speed.

Note: Voltage should not vary from phase to phase by more than 2% without derating the motor's horsepower rating. Damage may occur to the motor if operated with more variation.

**NOTE:** Check to make sure that input voltage is the same as the motor rated voltage. Proper voltage is required or permanent damage to the motor may occur.

2. Make sure the moisture detection system is operational at all times. Note that all mechanical seals must seep to provide lubrication to the rotating faces. The seep is trapped in the oil chamber between the inner and outer seals. During the initial run-in period, new seals may seep enough to cause the moisture alarm to go off. This is normal, change the oil and put the unit back into service.
3. Make sure both the suction (if required) and discharge valves are open.
4. Observe all caution, warning and danger tags that may be attached to the equipment.
5. Never run the pump longer than 15 minutes without liquid in the volute as close running fits within the pump are lubricated by the liquid. This condition may result in pump seizure, and/or seal damage.
6. Because of tight internal clearances these pumps should not run against a closed valve, unless approved by the factory.

### Starting the Pump

- A. Be sure the pump is submerged properly and that the liquid level exceeds the minimum operating level recommended.
- B. Refer to the motor nameplate for operation limits before proceeding.
- C. The pump requires no special procedures or adjustments before starting, except to check for rotation. The control system should be set to ensure no more than 10 across the line starts per hour.

**⚠ WARNING** Risk of explosion and fire. Pump water or sewage only with this pump. NEVER pump flammable liquids with this pump.

- D. Start the unit.
- E. Immediately after the pump has been started, check the following:
  - 1) Observe the unit for any unusual noise or vibration.
  - 2) The voltage should be within +/- 10% of the rated nameplate voltage across each phase. There should be no more than 2% variation between the average voltage and each leg.
  - 3) The amp reading of each phase should be less than the rated nameplate amps.
  - 4) Observe the unit for proper pressure and flow output.
  - 5) Continue to observe the unit's operation for at least the next four hours.
- F. For any problems, consult the "Troubleshooting" section of this manual.

### Stopping the Pump

Pump stations are usually designed to have the pumps started and stopped automatically. Since this is a function of station design, the operators should be familiar with the system's operating parameters. The general procedure to shut down the pump is as follows:

- A. Disconnect the electrical motor.
- B. If the pump is to be removed for repair, close the suction and discharge valves.

### Seasonal Operating Instructions

If the pump is located in an area that is subject to below freezing temperatures and will not be operated enough to prevent freezing, the sump and pump should be drained to prevent damage to the casing caused by freezing.

### Emergency Procedures

Many installations are equipped with emergency shut off switches near the pump location. These locations should be plainly marked and be readily accessible at all times.

The control panel (if used) may be equipped with an emergency start/stop button or switch.

**NOTE:** The operator or persons working around the equipment should be familiar with locations of emergency start-up and shut-off points.

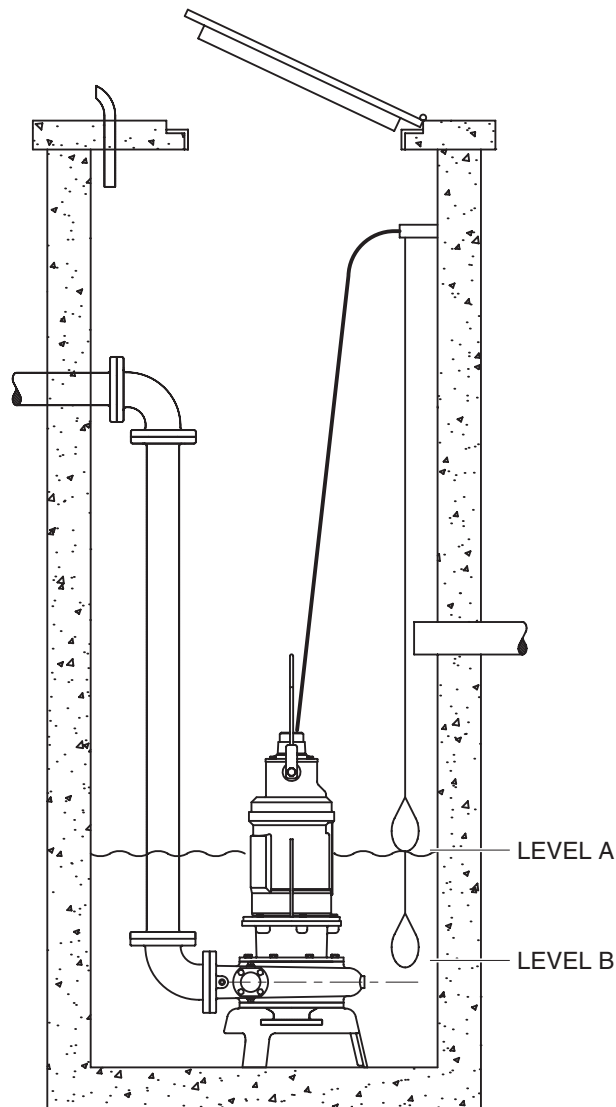

Figure 1: Typical Installation

Symptom	Probable Cause	Corrective Actions
<b>Insufficient Pressure or Flow</b>	<p>Wrong direction of rotation.</p> <p>Impeller running clearance too great.</p> <p>Speed too low.</p> <p>Impeller passage partially plugged.</p> <p>Insufficient net positive suction head.</p> <p>Air in liquid.</p> <p>Impeller damaged.</p> <p>Impeller diameter too small.</p> <p>Insufficient submergence.</p>	<p>Reverse any two motor lead connections.</p> <p>Check O&amp;M manual.</p> <p>Reset impeller clearance per O&amp;M manual.</p> <p>Check driver voltage and electrical source.</p> <p>Clean impeller passages.</p> <p>Raise wet well level.</p> <p>De-aerate liquid. Increase submergence to prevent vortexing.</p> <p>Check and repair or replace.</p> <p>Replace impeller with larger diameter. Check driver HP.</p> <p>Increase submergence.</p>
<b>Excessive Power Consumption</b>	<p>Pumping too much liquid.</p> <p>Speed too high.</p> <p>Improper line voltage or frequency.</p> <p>Incorrect diameter impeller.</p> <p>Internal rubbing.</p> <p>Shaft bent.</p> <p>Rotating element binds.</p> <p>Specific gravity or viscosity of liquid pumped is too high.</p>	<p>Change system. Reduce pump speed. Trim impeller.</p> <p>Check driver speed and voltage.</p> <p>Check driver voltage. Change power source or driver.</p> <p>Determine correct impeller diameter and replace or trim impeller.</p> <p>Replace shaft.</p> <p>Determine cause and correct.</p> <p>Reduce pump capacity.</p>
<b>Vibration or Noise</b>	<p>Pipe strain.</p> <p>Wrong rotation.</p> <p>Pumps too much liquid and exceeds NPSHR.</p> <p>Shaft bent.</p> <p>Vortexing</p> <p>Pump running at shut-off. Restricted discharge, internal recirculation.</p> <p>Air in liquid.</p> <p>Impeller passages plugged.</p>	<p>Improperly supported or aligned. Check pipe supports; adjust or realign.</p> <p>Reverse any two motor lead connections.</p> <p>Check O&amp;M manual.</p> <p>Increase system head. Reduce pump speed. Trim impeller.</p> <p>Replace shaft.</p> <p>Increase suction head.</p> <p>Open discharge valve. Check for obstructions.</p> <p>Increase submergence.</p> <p>Clean impeller passages.</p>
<b>Overheating</b>	<p>Shaft bent.</p> <p>Insufficient submergence.</p> <p>Rotating element binds.</p> <p>Excessive load.</p> <p>Excessive cycles.</p> <p>Excessively high or low voltage.</p> <p>Loss of internal oil.</p>	<p>Replace shaft.</p> <p>Increase submergence.</p> <p>Determine cause and correct.</p> <p>Increase system head. Check for mechanical interference.</p> <p>Change level controls, change system.</p> <p>Correct voltage source.</p> <p>Check oil level, check for bearing and seal damage.</p>
<b>Liquid Level Above High Limit</b>	<p>Excessive flow to wet well.</p> <p>Solids collecting around the pump suction reducing pump capacity.</p> <p>Controls improperly set on the high level.</p> <p>Improper sump design.</p> <p>Pump has been inoperative temporarily and excess water has accumulated in wet well.</p>	<p>Reduce influent. Increase pump capacity.</p> <p>Remove solids accumulation.</p> <p>Reset controls.</p> <p>Correct sump design.</p> <p>Operate pump to reduce level. (If a higher than normal water level has existed and was not witnessed, it can easily be detected by examining the sump for a scum line above the normal high level limit.)</p>

## TROUBLESHOOTING

If you have followed the installation and start up procedures outlined in this manual, your pump should provide reliable service and long life. However, if operating problems occur, significant time and expense can be saved if you use the following checklist to eliminate the most common causes of those problems.

## MAINTENANCE

### General

- A. With proper application of the pump/motor unit and proper installation of all the protective devices, no periodic maintenance of the equipment is necessary.
- B. Should the moisture detector indicate intrusion of moisture, the pump should be shut-down as soon as possible. Oil should be drained from the motor by removing the oil cavity inspection plug. Dispose of oil in accordance with local ordinances. With the motor in position with the inspection plug hole at the top, refill the seal chamber with the recommended oil (one port: 19 oz.; two or three ports: 28 oz.) and place the unit back in service. (In some cases, the seal faces require time to seal properly and some water may have passed by the seal faces into the seal oil chamber causing an alarm to signal.)

Note that all mechanical seals must seep to provide lubrication to the rotating faces. The seep is trapped in the oil chamber between the inner and outer seals. During the initial run-in period, new seals may seep enough to cause the moisture alarm to go off. This is normal, change the oil and put the unit back into service.

- C. Should a malfunction be indicated by the motor protection devices or observed in the operation of the pump, the pump should be removed, serviced, and the cause of the problem corrected. Refer to the **REPAIR PARTS** section of this manual for instructions on ordering.
- D. Motor overheating may be caused by an accumulation of foreign material collecting on the outside of the motor housing. The outside of the motor housing should be cleaned.

### Pump Disassembly

**NOTE:** Read this entire disassembly procedure and refer to the sectional drawings in this manual before starting.

- A. Prepare the pump for disassembly according to the following procedures:
  1. Disconnect and lock out the power to the motor.  
**▲WARNING** Risk of electrical shock and unexpected starts. Lock out and tag out all circuits connected to the motor before beginning to work on the pump or motor. Check with appropriate electrical test equipment to make sure that the motor cannot be accidentally started.
  2. Remove the pump and motor from the sump.
  3. Place the pump in an area where it can be cleaned and decontaminated thoroughly. Remove all scale and deposits on the pump. Submerge the complete pump in a disinfectant solution (chlorox or chlorine bleach) for at least one hour before disassembling the pump. Dispose of the bleach solution in accordance with local ordinances.

4. If pump/motor inspection, maintenance or repair must be performed at another location, disconnect the motor leads at the controller.
- B. Remove the capscrews holding the motor to the volute. Remove the motor and impeller assembly from the volute.
- C. Remove the impeller capscrew (9) and impeller washer (9A). Because the impeller capscrew (9) is installed with Loctite, it may be necessary to heat the capscrew to break the bond. Excessive heating may damage the lower seal.

**▲WARNING** Burn hazard. Wear heat resistant gloves when handling heated parts.

- D. Remove the impeller (1) and the impeller key (102) from the motor shaft.
  1. The impeller (1) has a straight bore fit, with a close tolerance. It may be necessary to use a wheel puller or similar device.
  2. Note the location and number of shims placed between the impeller hub and the shaft shoulder.  
**NOTE:** Care should be taken not to damage the impeller when using a puller or similar device. Attach the puller or other equipment behind the impeller vane area only. Do not try to pull against the unsupported impeller shroud.  
**NOTE:** Do not try to remove the shaft from the motor or disassemble any part of the motor.
  3. Store the motor in a clean, dry place if no motor repair is required.
- E. If the impeller or fronthead wear rings require replacement, or if the pump is to be retrofitted for wear rings, refer to the "WEAR RINGS" section of this manual. Always use original manufacturer's parts.  
**Note:** It is not necessary to remove the volute (30) from the fronthead (33) unless those items require service.
- F. If the fronthead (33) must be removed, remove the capscrews and remove from the volute (30). Remove the cleanout over (202) and gasket (203), if provided.

### Motor Disassembly

**NOTE:** The motor requires no periodic service, with the exception of changing the mechanical seal oil every 4000 hours of operation, not to exceed one year. Motor bearings are lubricated for life.

**CAUTION** UL Listing requirements do not permit disassembly or repairs of the motor by the owner, except for the replacement of the outer seal or the cable assembly. Motors must be returned to the factory or an authorized UL Listed Qualified Service Center.

- A. Cover/Cable Removal
  1. With the motor in a vertical position remove the cover capscrews, loosening slowly to allow any pressure to escape.
  2. Break the seal between the cover and the housing.
  3. Lift cover, turn over, and secure to housing with one cover capscrew.
  4. Remove the terminal board nuts and lead wires.
- B. Lower Mechanical Seal Removal
  1. Drain oil from seal chamber through the inspection plug (34G), and properly dispose of oil in accordance

with local ordinances.

2. Remove the rotary seal body clamp by removing the two locking screws.
3. Remove the rotating portion of the seal.
4. Remove the gland capscrews (31A).
5. Remove the gland (31).
6. Remove the stationary portion of seal from the gland.

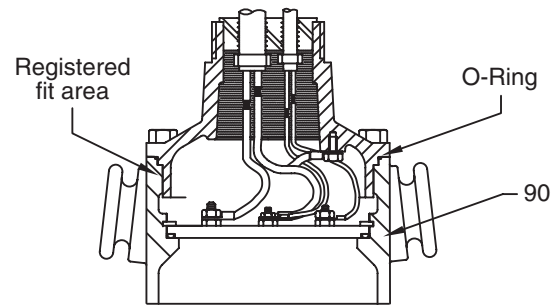

6239 0810

**⚠ WARNING** **Burn hazard. Allow the motor to cool before attempting to disassemble it.** Residual heat in the motor windings can cause high temperatures and pressures within the motor. Escaping hot gas or oil may cause serious burns.

**NOTE:** Normal maintenance does not require removal of the upper seal. Removal of the upper seal is not recommended as it requires draining and refilling the motor oil—also not recommended.

### Motor Assembly

**NOTE:** Read this entire assembly procedure before starting.

#### A. Outer Mechanical Seal and Gland Installation

1. Inspect the shaft.
2. Buff out all nicks that could cut the seal elastomer.  
**NOTE:** Exercise caution while buffing to avoid creating flat spots on the shaft under the elastomer. Wipe the shaft clean with a soft cloth. Keep the cloth out of the oil cavity.
3. Clean the machined surfaces.
4. Clean the oil cavity.
5. Install the gland O-ring (31B) on the gland (31).
6. Run a small bead of 515 Loctite® Form-a-Gasket around the face of the lower bearing housing (34).
7. Install the gland (31) and install the gland capscrews (31A).
8. Lubricate the viton O-ring on the stationary seal face with a water based rubber lubricant (P-80 or equal) and install it in the gland. Be sure the correct side (polished side) is facing up. Extreme care is to be taken not to damage the stationary seal face, and when installed, it is level and perpendicular to the shaft. It is recommended to measure down to at least three points on the seal face, at 120 degrees from each other. These dimensions should not vary more than 0.003".
9. Lubricate the inner diameter of the elastomer body of the rotating seal with a water based rubber lubricant (P-80 or equal).
10. Install the rotating portion of the seal. Be sure not to damage the seal when it passes over the step on the shaft. Take care as the seal body is sliding down the shaft. Try to keep the seal straight (not cocked) to the shaft and the ridge inside the seal body will seat in the groove in the shaft.
11. Install the retaining clamp, secure with the two locking screws.
12. Through the fill port on the side of the housing, fill the oil cavity (one port: 19 oz.; two or three ports: 28 oz.). Replace plug.

**B. Cover/Cable Assembly**

1. Install the cover O-Ring (32A) onto the cover.
2. Connect the control and power cable lead wires to the terminal board as shown on the drawings in the Auxiliary Diagrams section of this manual.
3. Run a small bead of 525 Loctite™ Form-a-Gasket around the motor housing (90) to seal it to the cover.

**CAUTION** 525 Loctite™ must be applied so as to keep it away from the o-ring and registered fit area.

4. Place the cover onto the motor housing or top motor housing and bolt up.

**Pump Assembly**

**NOTE:** Read this entire assembly procedure before starting. The following step-by-step instructions for assembly of the pump are essentially the reverse order of the instructions for disassembly.

- A. Prepare the pump for assembly according to the following procedures:
  1. Thoroughly clean all parts to remove all oil, grease and any foreign material.
  2. Inspect all parts including the motor shaft for wear or damage and replace if required.
  3. Gaskets should not be reused and should always be replaced.
- B. If the impeller or fronthead wear rings are being replaced, or if the pump is to be retrofitted for wear rings, refer to the "Wear Rings" section of this manual. Always use original manufacturer's parts.
- C. Thoroughly clean the impeller bore, the end of the shaft, the shaft and keyway.
  1. Inspect and measure the impeller bore, the shaft fit diameter, the key and the keyway for wear.

**NOTE:** Measure in several locations along the length of the fit.

  2. If wear is noticed and the clearance between the

shaft and the impeller (1) exceeds 0.003" anywhere along the length of the impeller bore, contact the factory for instructions for rework or replacement of the components.

3. Install the impeller key (102) in the motor shaft. Replace the shaft shims and if provided the circulator. Slide the impeller (1) in place, making sure it butts firmly against the shaft shims or circulator.
  4. With the impeller washer (9A) in place, install the impeller capscrew (9) and tighten it to 60 ft.-lbs torque.
- D. If the volute (30) and fronthead (33) have been removed proceed as follows:
1. Use new cleanout cover gaskets (203) and install the cleanout cover (202), if provided.

**Seal Oil**

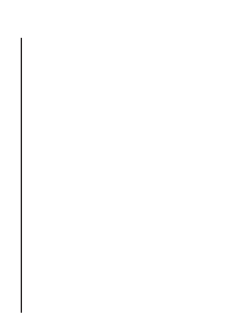

**3-PHASE MOTOR LEAD SIDE CONNECTIONS**

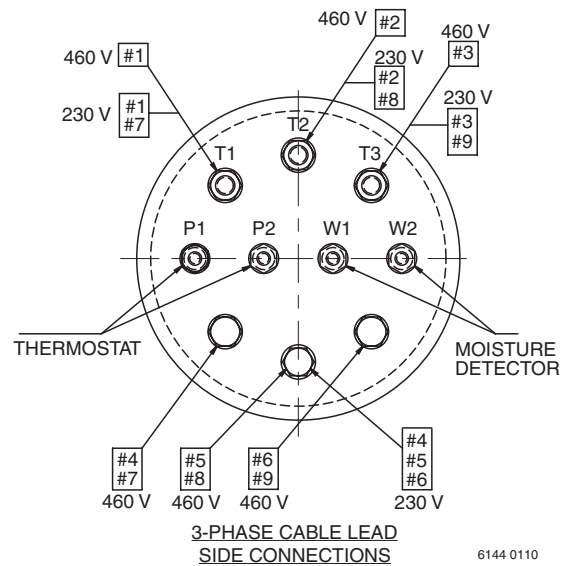
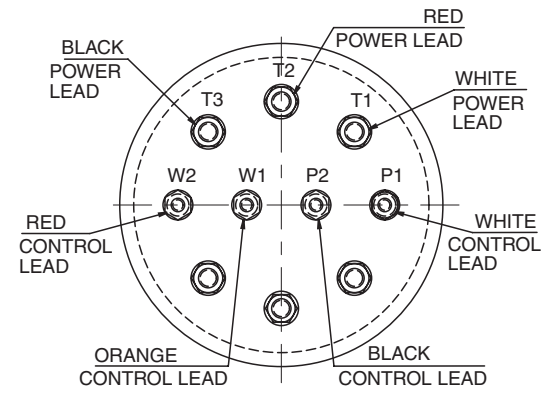

6144 0110

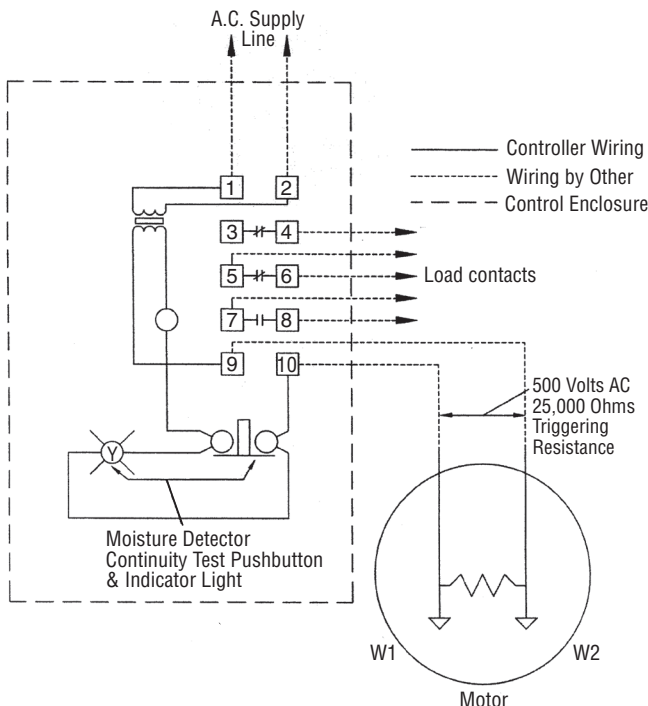

**Figure 2: Moisture Detection Controller Wiring Diagram**

**Figure 3: Dual Voltage Terminal Board Connections**

### 4BSW4 Parts List

Key No.	Item	4" D5431W-5HP	4" D5431W-7.5HP	4" D5432W-10HP	4" D5432W-15HP
	<b>Engineering Number (230V)</b>	<b>B85654</b>	<b>B85655</b>	<b>B85656</b>	<b>B85657</b>
	<b>Engineering Number (460V)</b>	<b>B85658</b>	<b>B85659</b>	<b>B85660</b>	<b>B85661</b>
M	Motor (230 Volt)	U005C2214A1X	U007C2214A1X	U010C2214B1X	U015C2214B1X
M	Motor (460 Volt)	U005D2214A1X	U007D2214A1X	U010D2214B1X	U015D2214B1X
B	Lifting Bail	CP8984AA 2280 F	CP8984AA 2280 F	CP8984AA 2280 F	CP8984AA 2280 F
BA	Lifting Bail Capscrews	(2) 11FM7A0111 0005 F	(2) 11FM7A0111 0005 F	(2) 11FM7A0111 0005 F	(2) 11FM7A0111 0005 F
1	Impeller	T4A1FG675	T4A1FG760	T4B1MG770	T4B1MG865
9	Impeller Capscrew	11FM7A0113 0003 F	11FM7A0113 0003 F	11FM7A0114 0003 F	11FM 7A0114 0003 F
9A	Impeller Washer	CP5855AN 9660 F	CP5855AN 9660 F	CP5855AN 9660 F	CP5855AN 9660 F
15	Vertical Base	T4A15J 0220 F	T4A15J 0220 F	T4A15J 0220 F	T4A15J 0220 F
15A	Base Capscrews	(8) 11FM7A0174 0005 F	(8) 11FM7A0174 0005 F	(8) 11FM7A0174 0005 F	(8) 11FM7A0174 0005 F
15B	Base Capscrew Nuts	(8) 11FM25A10007 0005 F	(8) 11FM25A10007 0005 F	(8) 11FM25A10007 0005 F	(8) 11FM25A10007 0005 F
16	Volute Wear Ring	T4A16A 9630 F	T4A16A 9630 F	N/A	N/A
16	Fronthead Wear Ring	N/A	N/A	T4C16AF 9630 F	T4C16AF 9630 F
30	Volute	T4A30AG 0220 F	T4A30AG 0220 F	T4B30AK 0220 F	T4B30AK 0220 F
30A	Volute Capscrews	(8) 11FM7A0056 0005 F	(8) 11FM7A0056 0005 F	(8) 11FM7A0112 0005 F	(8) 11FM7A0112 0005 F
33	Pipe Plug	N/A	N/A	(5) 20FM7D0004 0008 F	(5) 20FM7D0004 0008 F
33A	Fronthead	N/A	N/A	T4B33AZ 0220 F	T4B33AZ 0220 F
102	Fronthead Capscrews	N/A	N/A	(8) 11FM7A0112 0005 F	(8) 11FM7A0112 0005 F
156	Impeller Key	16FM104S0194 4780 F	16FM104S0194 4780 F	16FM104S0194 4780 F	16FM104S0194 4780 F
186	Volute Gasket	T3A155A 8380 F	T3A155A 8380 F	(2) CP2930 8380 F	(2) CP2930 8380 F
186	Impeller Hub Shim (.015")	(2) CP5819AA 2280 F	(2) CP5819AA 2280 F	(4) CP5819AA 2280 F	(4) CP5819AA 2280 F
186	Impeller Hub Shim (.005")	(4) CP5819AB 2280 F	(4) CP5819AB 2280 F	(2) CP5819AB 2280 F	(2) CP5819AB 2280 F
202	Handhole Cover	N/A	N/A	T4C202A 3980 F	T4C202A 3980 F
*202A	Handhole Cover Capscrews	N/A	N/A	(4) 11FM7A0112 0005 F	(4) 11FM7A0112 0005 F
*203	Handhole Cover Gasket	N/A	N/A	TBGA467A 7880 F	TBGA467A 7880 F

Parts below are a part of the motor cost above:

32	Cover/Cable Assembly (Includes Key Nos. 32A, 90E)	CP8986H25	CP8986H25	CP8986K25	CP8986L25
32A	Cover/Cable Assembly O-Ring (Included with Cover/Cable Assembly, Key No. 32)	HYD6E114	HYD6E114	HYD6E114	HYD6E114
34D	Water Sensor Probe	*	*	*	*
34G/H	Drain/Fill Plugs	(2) HYD42U1 9906 F	(2) HYD42U1 9906 F	(2) HYD42U1 9906 F	(2) HYD42U1 9906 F
90E	Terminal Board Assembly	CP9003J 1111A	CP9003J 1111A	CP9003J 1111A	CP9003J 1111A
90F	Terminal Board Retaining Ring	HYD37A11 9906F	HYD37A11 9906F	HYD37A11 9906F	HYD37A11 9906F
.	Inner Mechanical Seal	*	*	*	*
456	Outer Mechanical Seal	HYD1EW1 9906 F	HYD1EW1 9906 F	HYD1EW1 9906 F	HYD1EW1 9906 F

\* Replaceable only by an Authorized Motor Repair Station.

• Not illustrated.

F

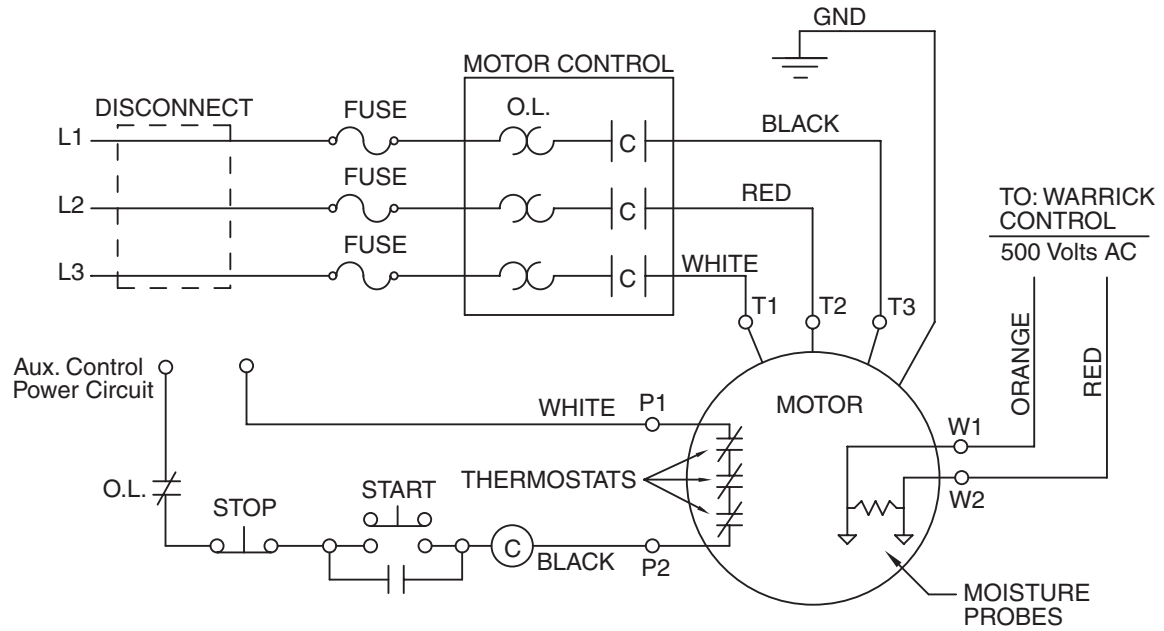

Submersible Motor Wiring Diagram  
for 210T and 220T Frame Motors

6141 0110

Figure 4: Submersible 210T Frame Motor Wiring Diagram.

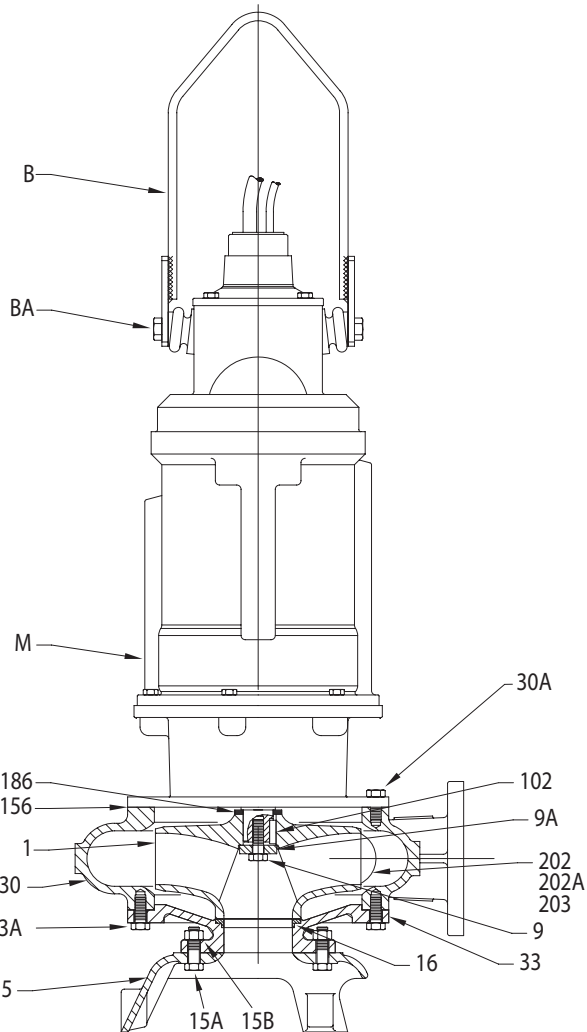

Figure 5: Submersible Solids Pump Assembly Drawing.

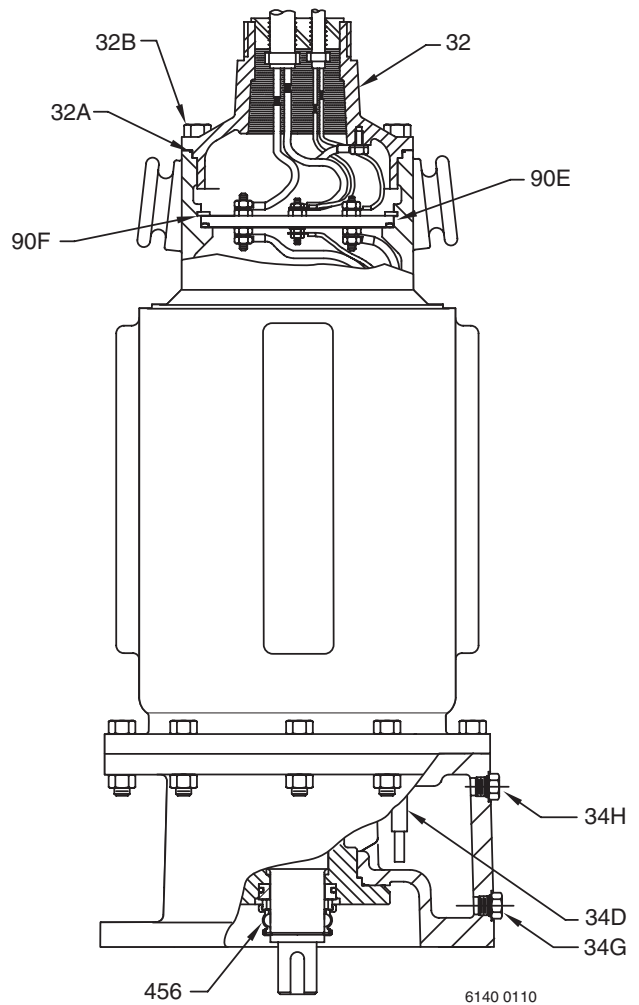
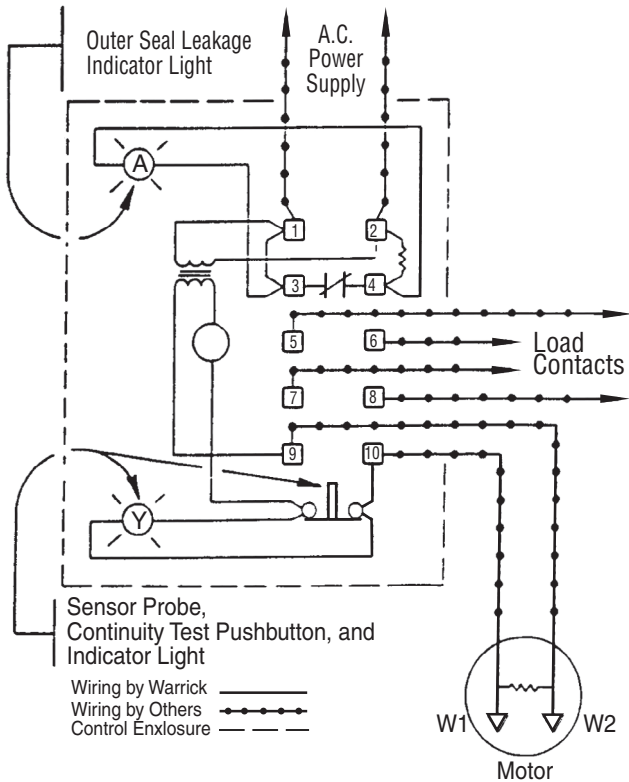
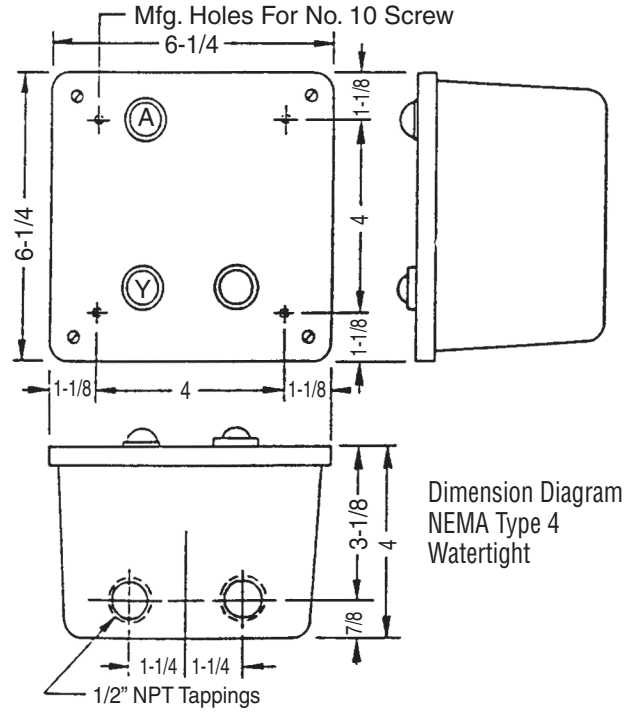

Figure 6: Submersible Solids 210 Frame Motor Assembly Drawing.

6140 0110



**Figure 7:** Connections for Warrick Moisture Detection Controls



**Figure 9:** Dimension drawing, NGMA Type 4 Watertight Control Housing

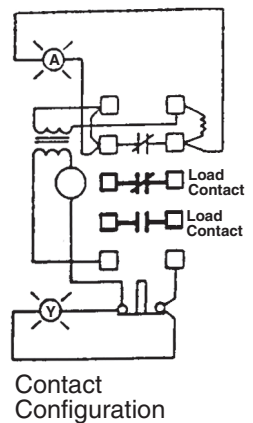

**Figure 8:** Contact configuration for Warrick Moisture Detection Controls