



e-HMX Smart Pumps

INTEGRATED PUMP, MOTOR & VARIABLE SPEED DRIVE SOLUTIONS
powered by hydrovar® X

Contents

Example Product Code	3
e-HMX Series Hydraulic Coverage Curves	4
e-HMX Series Benefits	5
e-HMX Series with Drive and hydrovar X Applications & Specifications	6
e-HMX Nameplate	7
e-HMX Series Model List and General Characteristics	7
Maximum Power and Current Consumption	8
hydrovar X Noise	8
Mechanical Seals.....	8
Major Components.....	9
Table of Materials	9
e-HMX Series Mechanical Seals	10
e-HMX All Models Dimensions and Weights	11
Terminal Block.....	12
How to Read Smart Pump Series Curves.....	13
Hydraulic Performance Curves	14
Technical Data - Water Property Chart.....	25
Technical Data - Compatibility Chart for Materials	26
Technical Data - NPSH	27

Xylem Solver

We are continuously working with our customers to help with selecting the right pumps to meet the demands of a wide range of applications. Xylem Solver, our user-friendly online selection tool is also available with multiple search options and helpful product information to help with pump configuration.

Solver can be available: at <https://solver.xylem.com/>

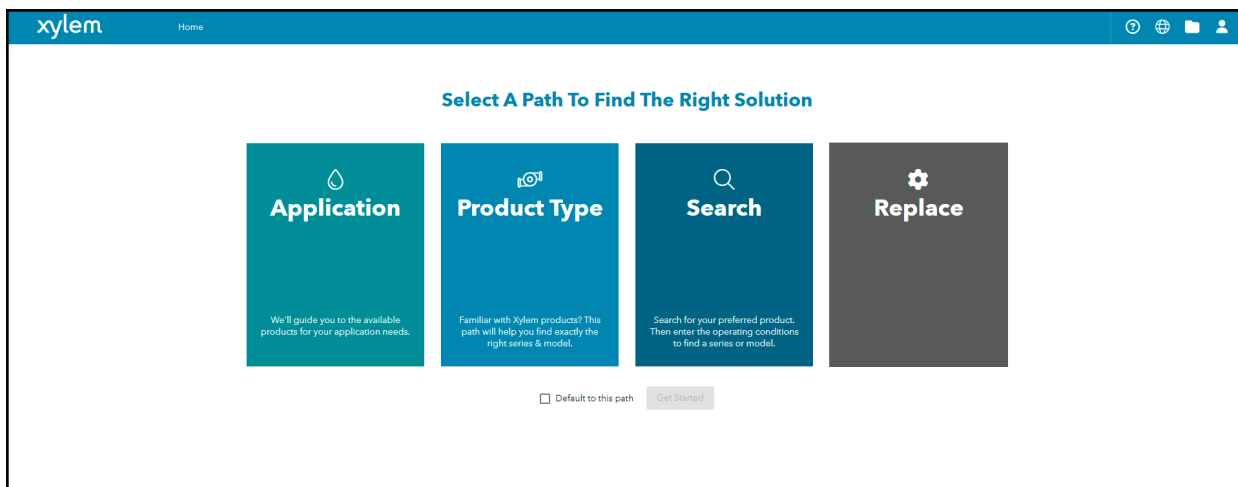

Example Product Code

10	HMX	08	N	55	T	M6	BQE	
----	-----	----	---	----	---	----	-----	--

Special Configuration

Seal Materials

BQE = Carbon-SilCar-EPDM (standard)

BQV = Carbon-SilCar-Viton

QQE = SilCar-SilCar-EPDM

QQV = SilCar-SilCar-Viton

BVE = Carbon-Ceramic-EPDM

QQK = SilCar-SilCar-Kalrez

BQK = Carbon-SilCar-Kalrez

Hz-Phase-Voltage

M5 = 50/60 - 3 - 200-240V

M6 = 50/60 - 3 - 380-480V

Phase

T = 3

HP

30 = 4 hp

40 = 5.5 hp

55 = 7.5 hp

Construction

N = 316 Stainless Steel

Total Number of Stages

Product Line

HMX = Stainless Horizontal Multistage with hydrovar X

Nominal Flow

3 = 16 GPM

5 = 33 GPM

10 = 56 GPM

15 = 90 GPM

22 = 100 GPM

* Not all combinations are valid

e-HMX Series Hydraulic Coverage Curve

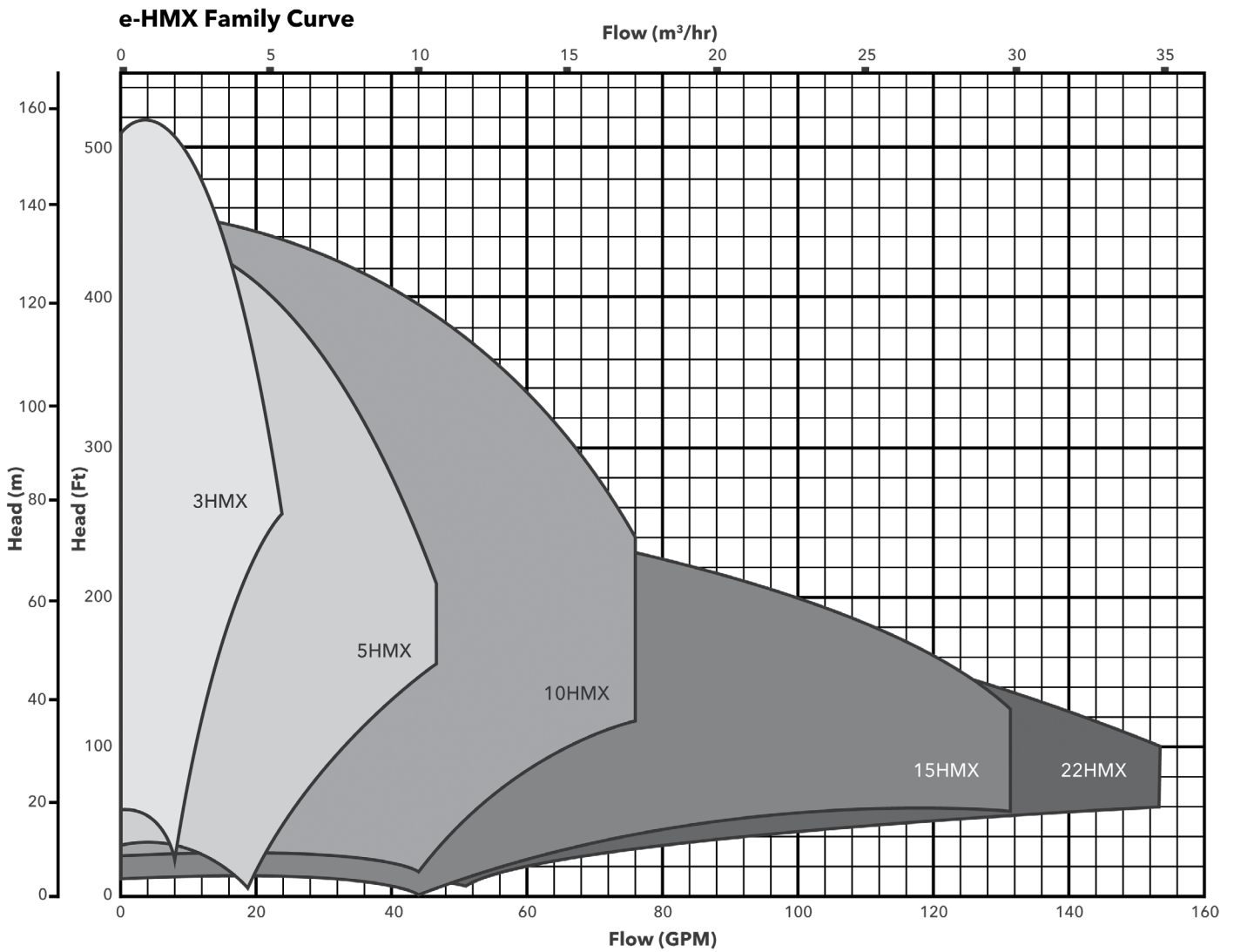

Commercial Water

e-HMX SERIES

Applications, Benefits and Industry

Powered by Xylem's hydrovar® X Smart Motor, e-HMX Smart Pumps offer customizable pumping solutions designed to deliver ultra-premium efficiency, connectivity, and simplicity right out of the box!

e-HMX Smart Pumps integrate decades of expertise and know-how in pumping solutions to bring the right combination of motors, variable speed drive and hydraulic pumps in one comprehensive, highly efficient package. It is a versatile horizontal multistage pump designed for best-in-class efficiency and superior durability to reduce the total cost of ownership. Customizable options mean you get exactly the right pump for your application, exactly when you need it.



So, when it's time to think efficiency, performance and reliable market-leading technology ... start with e-HMX Smart Pumps from Goulds Water Technology - a complete system, delivering the solutions you need for today.

BENEFITS:

The e-HMX provides the following benefits:

More performance for less cost. The e-HMX is a high-performance smart pump with full pressure-boosting capabilities—using significantly less energy. With the e-HMX, users can do more, while spending less!

Reliability: The e-HMX pump is made of 316 stainless steel and construction incorporating a 20% increase in the pump body thickness, ensures enhanced durability and reliability. The balanced impeller reduces axial thrust 40%, extending motor bearing life.

Ease of installation and maintenance: the integrated pump and hydrovar X motor package eliminates additional wiring, labor, and costs associated with a traditional variable frequency drive (VFD) package. The hydrovar X motor features a quick-connect electrical socket between the motor and drive for rapid maintenance.

Intelligent performance: advanced control systems embedded within the hydrovar X motor are customizable for a wide range of applications and multi-pump support (up to 8 pumps) for parallel pumping installations.

Simple: the hydrovar X motor is easy to configure and commission. Follow the start-up genie to quickly tailor the motor to its intended application. Control selections and navigate menus via a full color graphical display.

Built-in protections: integrated functions protect the pump and motor when operating near the current and power limits of the system.

High efficiency: the IE5 "ultra-premium" hydrovar X motor provides one of the broadest efficiency ranges in the industry.

e-HMX SERIES WITH DRIVE AND HYDROVAR X (PERMANENT MAGNET MOTOR)

Applications:

Designed with compactness in mind, the e-HMX is ideal for applications where a smaller footprint is needed. With two designs, six models and modular construction, it's completely customizable and can be configured for a wide range of applications: It's an ideal solution for industrial, building services and residential applications including:

- pressure boosting and water supply systems
- industrial washing and cleaning
- water treatment
- circulation of hot and cold liquids in heating, cooling and conditioning systems

e-HMX Smart Pump Specifications:

- Flow rate: up to 150 GPM (34 m³/h)
- Head: up to 509 ft (155 m)
- Temperature of pumped liquid: 20°F to 248°F (-30°C to 120°C)
- Maximum operating pressure: 235 psi (16 bar)
- Environment operating temperature: -4°F to 122°F (-20°C to 50°C)
- Storage and transport temperature: -40°F to 140°F (-40C to 60C)



For a full list of features and specifications of the hydrovar X motor, please scan the QR code below to see more documentation.



hydrovar X Motor Specifications:

- Graphical color display
- Control Modes include: actuator, constant pressure, proportional pressure, proportional quadratic pressure, constant flow, constant temperature, constant level
- Multi-pump linking: up to 8 pumps
- IP55 / NEMA 4 enclosure
- Working temperature: -4°/+122°F (-20°/+50°C)
- RS485 Communication interface, BACnet and MODBUS® standard and BLE included
- IES2 Power drive system (PDS) efficiency (IEC 61800-9-2:2017)
- IE5 Motor efficiency (IEC TS 60034-30-2:2016)
- Insulation Class 115 (Class F)
- Totally enclosed fan cooled (TEFC) construction
- 3-Phase power supply
- Rated speeds (high speed models): 3000 - 4000 RPM³
- Rated speeds (low speed models): 1500 - 2000 RPM³
- High speed models: 3 kW to 22 kW (4 HP to 30 HP): 200-240V and 380-480V +/- 10%, 50/60Hz
- Low speed models: 1.5 kW to 11 kW (2 HP to 15 HP): 200-240V and 380-480V +/- 10%, 50/60Hz
- Overload and locked rotor protection with automatic reset included

³ Rated speeds are used to determine the net efficiency of a pump-drive system and for energy efficiency listings. Pumps may or may not utilize the full speed range of hydrovar X depending on a variety of factors or limitations. Models may operate below rated speed at partial loading. See individual performance curves for more detail.

Commercial Water

e-HMX NAMEPLATE

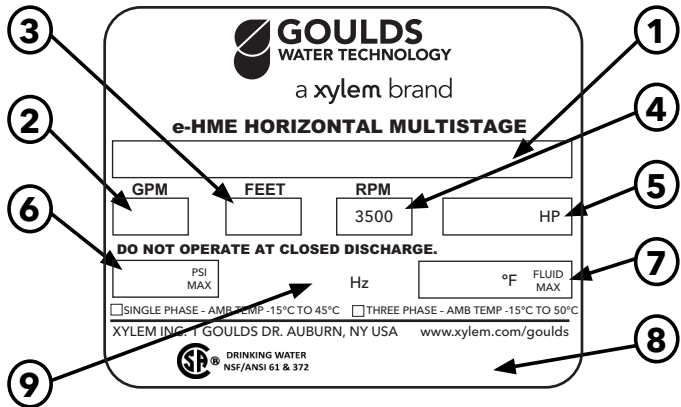

1	Catalog Number
2	Capacity Range
3	TDH Range
4	Rated Speed
5	Rated Horsepower
6	Maximum Operating Pressure
7	Maximum Fluid Temperature
8	Pump Serial Number
9	Rated Hz

e-HMX SERIES MODEL LIST AND GENERAL CHARACTERISTICS

e-HMX	Stages	Frame	Voltage	Motor Type	Motor HP	Motor PN	Temperature Range	MWP (psi)	Motor Weight (lbs)	Pump + Motor Weight (lbs)
3HMX	14	90HMHB	380-480	EXM90HMHB/4.040BH2	4	100638293	-20° to 248°F	235	46	65
5HMX	09	90HMHB		EXM90HMHB/4.040BH2	4	100638293	-20° to 248°F	235	46	65
5HMX	12	90HMHB		EXM90HMHB/4.040BH2	4	100638293	-20° to 248°F	235	46	71
10HMX	04	90HMHC		EXM90HMHC/4.040BH2	4	100638303	-20° to 248°F	235	46	69
10HMX	05	100HMHC		EXM100HMHC/4.055BH2	5.5	100638313	-20° to 248°F	235	48	72
10HMX	08	112HMHC		EXM112HMHC/4.075BH2	7.5	100638320	-20° to 248°F	235	56	78
15HMX	02	90HMHC		EXM90HMHC/4.040BH2	4	100638303	-20° to 248°F	235	46	67
15HMX	03	100HMHC		EXM100HMHC/4.055BH2	5.5	100638313	-20° to 248°F	235	48	69
15HMX	04	112HMHC		EXM112HMHC/4.075BH2	7.5	100638320	-20° to 248°F	235	56	72
22HMX	02	100HMHC		EXM100HMHC/4.055BH2	5.5	100638313	-20° to 248°F	235	48	67
22HMX	03	112HMHC		EXM112HMHC/4.075BH2	7.5	100638320	-20° to 248°F	235	56	75
3HMX	14	90HMHB		200-240	EXM90HMHB/3.040BH2	4	100638291	-20° to 248°F	235	46
5HMX	09	90HMHB	EXM90HMHB/3.040BH2		4	100638291	-20° to 248°F	235	46	65
5HMX	12	90HMHB	EXM90HMHB/3.040BH2		4	100638291	-20° to 248°F	235	46	71
10HMX	04	90HMHC	EXM90HMHC/3.040BH2		4	100638301	-20° to 248°F	235	46	69
15HMX	02	90HMHC	EXM90HMHC/3.040BH2		4	100638301	-20° to 248°F	235	46	67

MAXIMUM POWER AND CURRENT CONSUMPTION (3600 RPM)

e-HMX	Stages	Voltage	HP	Frame	Motor Type	Max Input Power (kW)	Max Input Current (A)
3HMX	14	460	4	90HMHB	EXM90HMHB/4.040BH2	2.64	4.84
3HMX	14	230	4	90HMHB	EXM90HMHB/3.040BH2	2.67	8.23
5HMX	09	460	4	90HMHB	EXM90HMHB/4.040BH2	2.84	5.21
5HMX	09	230	4	90HMHB	EXM90HMHB/3.040BH2	2.87	8.85
5HMX	12	460	4	90HMHB	EXM90HMHB/4.040BH2	3.38	6.2
5HMX	12	230	4	90HMHB	EXM90HMHB/3.040BH2	3.44	10.61
10HMX	04	460	4	90HMHC	EXM90HMHC/4.040BH2	3.08	5.65
10HMX	04	230	4	90HMHC	EXM90HMHC/3.040BH2	3.12	9.62
10HMX	05	460	5.5	100HMHC	EXM100HMHC/4.055BH2	3.82	6.51
10HMX	08	460	7.5	112HMHC	EXM112HMHC/4.075BH2	6.08	9.9
15HMX	02	460	4	90HMHC	EXM90HMHC/4.040BH2	3.02	5.54
15HMX	02	230	4	90HMHC	EXM90HMHC/3.040BH2	3.06	9.44
15HMX	03	460	5.5	100HMHC	EXM100HMHC/4.055BH2	4.58	7.81
15HMX	04	460	7.5	112HMHC	EXM112HMHC/4.075BH2	6.13	9.98
22HMX	02	460	5.5	100HMHC	EXM100HMHC/4.055BH2	4.36	7.43
22HMX	03	460	7.5	112HMHC	EXM112HMHC/4.075BH2	6.19	10.08

hydrovar X NOISE¹

Motor Type	Power [HP]	Sound Pressure (dBA) ± 2dB	
		3000 RPM	3600 RPM
EXM90HMHB/4.040BH2	4	61	64
EXM90HMHC/4.040BH2			
EXM90HMHB/3.040BH2			
EXM90HMHC/3.040BH2			
EXM100HMHC/4.055BH2	5.5	61	64
EXM112HMHC/4.075BH2	7.5	61	64

¹ Sound power measured at 1m distance in no-load condition according to ISO 9614-2 and sound pressure values determined according to the ISO 11203 method.

3HMX, 5HMX, 10HM, 15HMX, 22HMX

MECHANICAL SEALS: PRESSURE AND TEMPERATURE LIMITS

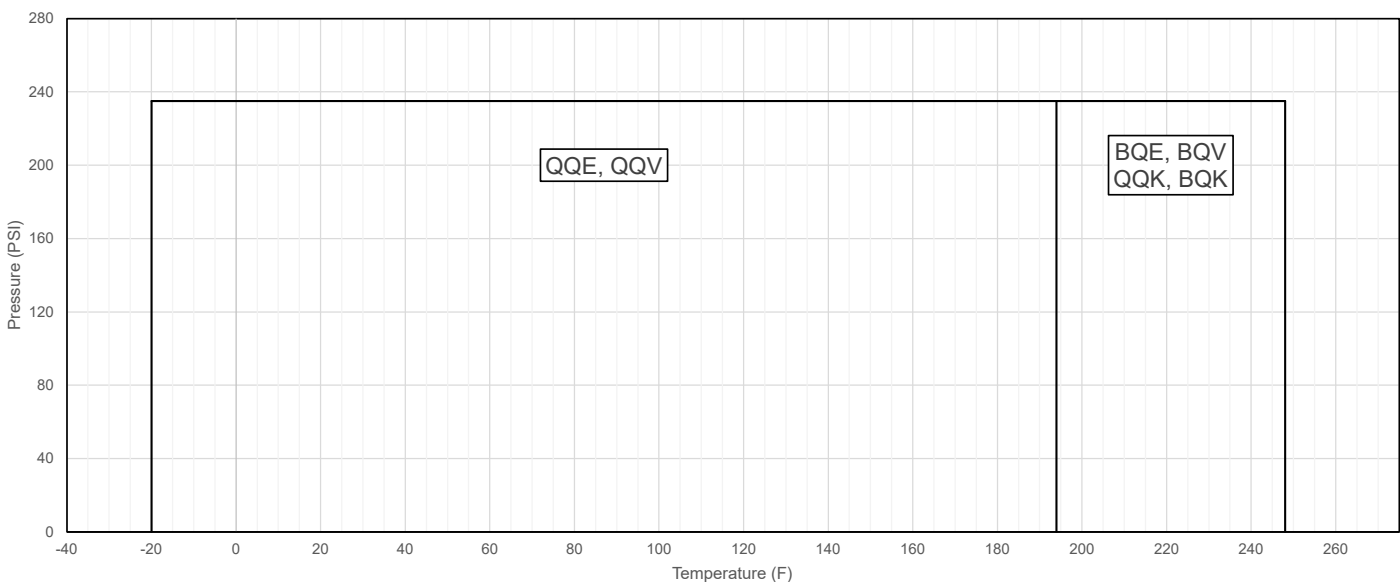

Commercial Water

MODEL 3, 5, 10, 15, 22 HM..N SERIES - MAJOR COMPONENTS

e-HMX series pumps utilize the standard construction of e-HM (sleeve design) pumps as depicted below.

Liquid End Materials of Construction (Sleeve Design)

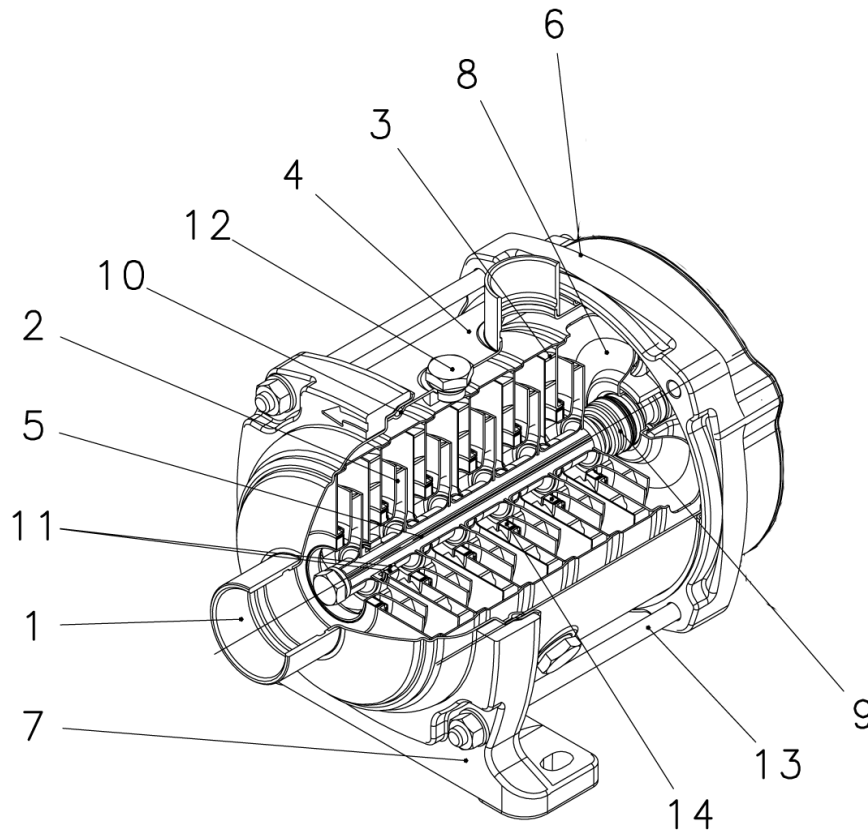
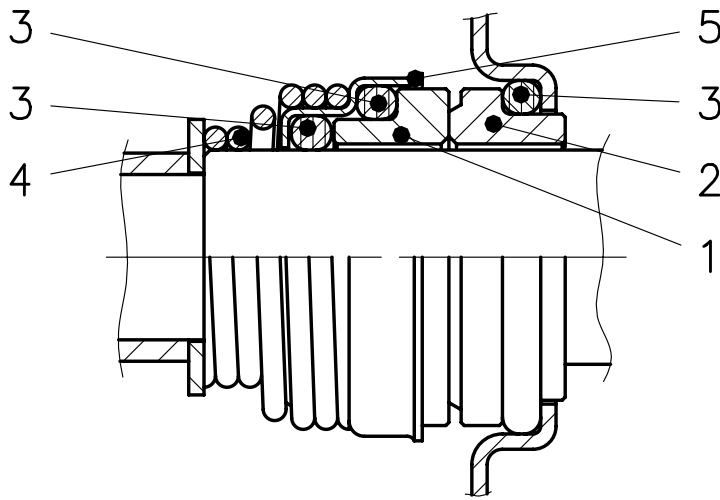

TABLE OF MATERIALS HM..N SERIES

REFERENCE NUMBER	NAME	MATERIAL	REFERENCE STANDARDS	
			USA	EUROPE
1	Head	Stainless steel	AISI 316L	EN 10088-1-X2CrNiMo17-12-2 (1.4404)
2	Impeller	Stainless steel	AISI 316L	EN 10088-1-X2CrNiMo17-12-2 (1.4404)
3	Diffuser and upper spacer	Stainless steel	AISI 316L	EN 10088-1-X2CrNiMo17-12-2 (1.4404)
4	Outer sleeve	Stainless steel	AISI 316L	EN 10088-1-X2CrNiMo17-12-2 (1.4404)
5	Shaft	Stainless steel	AISI 316	EN 10088-1-X5CrNiMo17-12-2 (1.4401)
6	Adapter	Aluminium	-	EN 1706-AC-AISI11Cu2 (Fe) (AC46100)
7	Ring with foot	Aluminium	-	EN 1706-AC-AISI11Cu2 (Fe) (AC46100)
8	Seal housing	Stainless steel	AISI 316L	EN 10088-1-X2CrNiMo17-12-2 (1.4404)
9	Mechanical seal	Ceramic / Carbon / EPDM (PN10) - Silicon Carbide/Carbon/EPDM (PN16)		
10	Elastomers	EPDM		
11	Shaft sleeve and bushing	Tungsten carbide		
12	Fill / drain plugs	Stainless steel	AISI 316L	EN 10088-1-X5CrNiMo17-12-2 (1.4401)
13	Tie rods	Stainless steel	AISI 431	EN 10088-1-X17CrNi16-2 (1.4057)
14	Wear ring	Technopolymer (PPS)		

e-HMX SERIES MECHANICAL SEALS



LIST OF MATERIALS

Components	Part Number			
	1	2	3	4 and 5
	Rotary Face	Stationary Face	Elastomers	Hardware
Materials	B - Carbon		E - EPDM (EPR)	All 316 SS
	Q - Sil Carbide		V - Viton	
	V - Ceramic		K - Kalrez	

PRESSURE AND TEMPERATURES LIMITS

Seal Code	3HMX, 5HMX, 10HMX, 15HMX, 22HMX
BQE	235PSI at 248F
BQV	235PSI at 248F
QQE	235PSI at 194F
QQV	235PSI at 194F
BVE	Not Available
QQK	235PSI at 194F
BQK	235PSI at 248F

Commercial Water

e-HMX ALL MODELS DIMENSIONS AND WEIGHTS

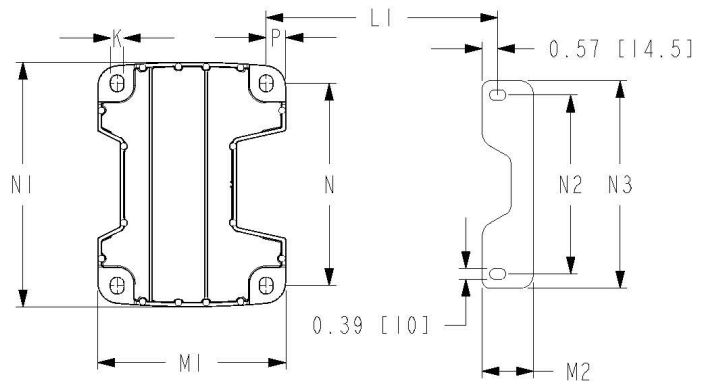
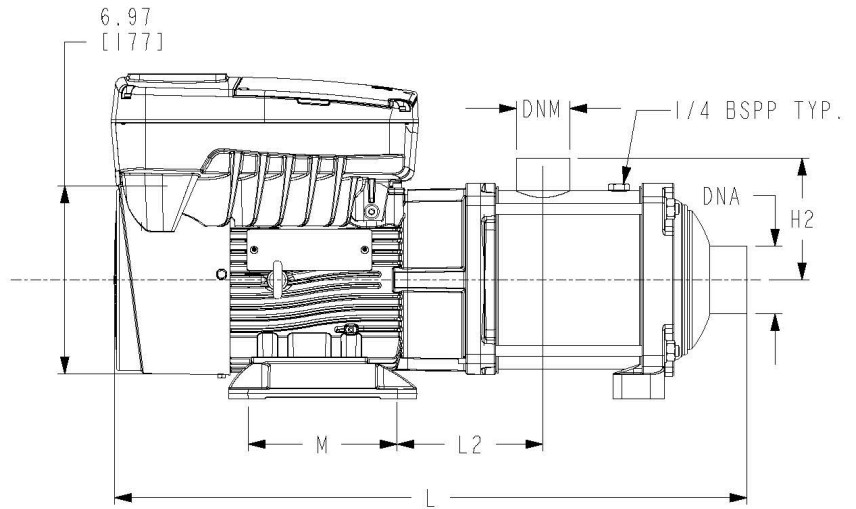
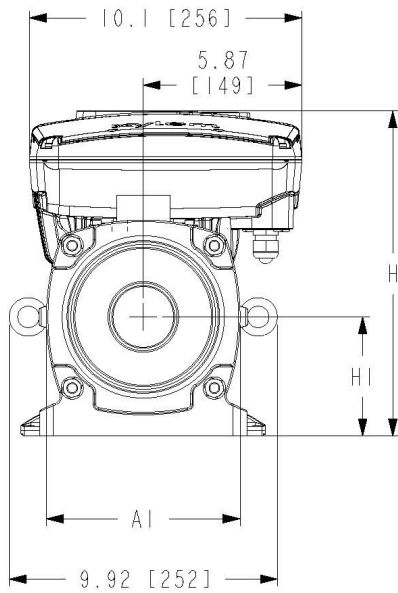

e-HMX	Motor			NPT (in.)		Dimensions (in)																MWP (psi)	Weight (lbs)	
	Frame	Motor Type	HP	DNA	DNM	A	A1	H	H1	H2	L	L1	L2	M	M1	M2	N	N1	N2	N3	P			K
3HMX14	90	EXM90HMHB/4.040BH2	4	1	1	7.52	5.51	11.18	3.54	3.7	26.54	12.21	8.67	4.92	6.14	1.77	5.51	6.85	5.51	6.5	0.63	0.39	235	65
5HMX09	90	EXM90HMHB/4.040BH2	4	1.25	1	9.17	5.51	11.18	3.54	3.7	24.28	9.85	4.76	4.92	6.14	1.77	5.51	6.85	5.51	6.5	0.63	0.39	235	65
5HMX12	90	EXM90HMHB/4.040BH2	4	1.25	1	12.13	5.51	11.18	3.54	3.7	27.23	12.8	4.76	4.92	6.14	1.77	5.51	6.85	5.51	6.5	0.63	0.39	235	71
10HMX04	90	EXM90HMHC/4.040BH2	4	1.5	1.25	6.18	7.17	11.18	3.54	4.45	21.33	6.72	4.8	4.92	6.14	1.89	5.51	6.85	6.61	7.68	0.63	0.39	235	69
10HMX05	100	EXM100HMHC/4.055BH2	5.5	1.5	1.25	7.44	7.17	11.57	3.94	4.45	22.59	7.66	4.49	5.51	6.81	1.89	6.3	7.64	6.61	7.68	0.67	0.47	235	72
10HMX08	112	EXM112HMHC/4.075BH2	7.5	1.5	1.25	11.22	7.17	12.05	4.41	4.45	26.38	11.72	4.76	5.51	6.97	1.89	7.48	9.06	6.61	7.68	0.33	0.47	235	78
15HMX02	90	EXM90HMHC/4.040BH2	4	2	1.5	5.67	7.17	11.18	3.54	4.49	21.45	6.72	5.43	4.92	6.14	1.89	5.51	6.85	6.61	7.68	0.63	0.39	235	67
15HMX03	100	EXM100HMHC/4.055BH2	5.5	2	1.5	5.67	7.17	11.57	3.94	4.49	21.45	6.4	4.06	5.51	6.81	1.89	6.3	7.64	6.61	7.68	0.67	0.47	235	69
15HMX04	112	EXM112HMHC/4.075BH2	7.5	2	1.5	7.56	7.17	12.05	4.41	4.49	23.34	8.57	5.39	5.51	6.97	1.89	7.48	9.06	6.61	7.68	0.33	0.47	235	72
22HMX02	100	EXM100HMHC/4.055BH2	5.5	2	1.5	5.67	7.17	11.57	3.94	4.49	21.45	6.4	5.12	5.51	6.81	1.89	6.3	7.64	6.61	7.68	0.67	0.47	235	67
22HMX03	112	EXM112HMHC/4.075BH2	7.5	2	1.5	5.67	7.17	12.05	4.41	4.49	21.45	6.68	5.39	5.51	6.97	1.89	7.48	9.06	6.61	7.68	0.33	0.47	235	75

Commercial Water

e-HMX SERIES hydrovar X Terminal Block Diagram

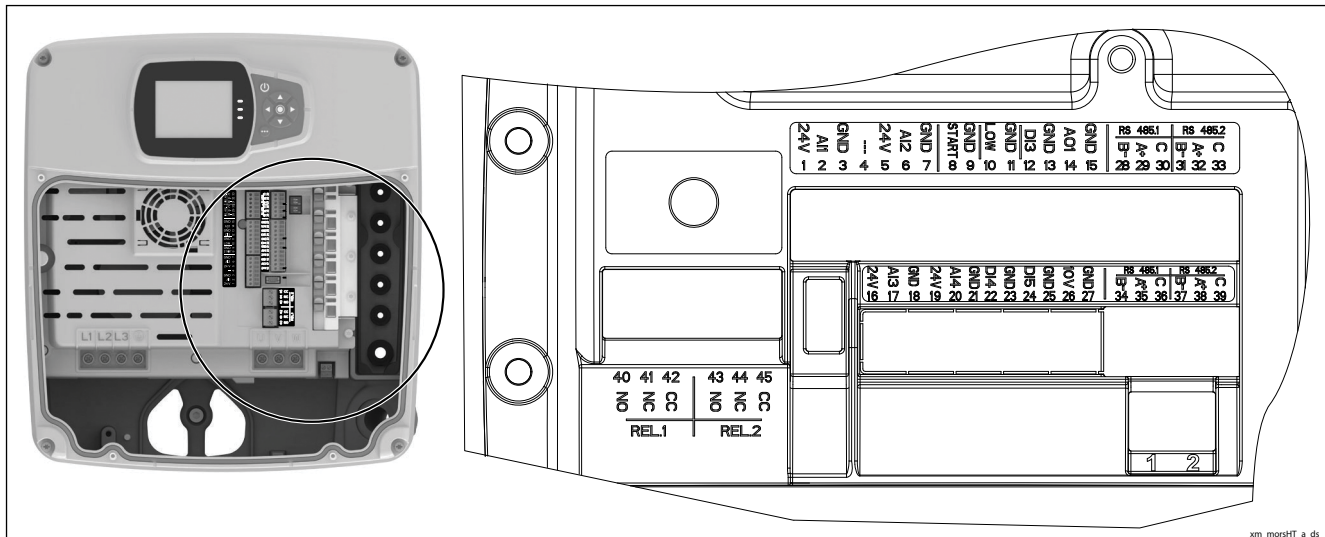

REF.	ITEM	DESCRIPTION	DEFAULT
1		Power supply +24 VDC, max. 60mA (total, terminals 1 + 5)	
2	Analog Input 1	Configurable Analog Input 1	Pressure Sensor 1
3		Electronic GND	
4	Not used	Internal use - Do not connect	
5		Power supply +24 VDC, max. 60mA (total, terminals 1 + 5)	
6	Analog Input 2	Configurable Analog Input 2	Not used
7		Electronic GND	
8	External Start/Stop	Start/Stop digital input, +24 VDC internal pull-up, 6mA contact current	-
9		Electronic GND	
10	External Lack of Water	Low water digital input, +24 VDC internal pull-up, 6mA contact current	-
11		Electronic GND	
12	Digital Input 3	Configurable Digital Input 3, +24 VDC internal pull-up, 6mA contact current	Solo Run
13		Electronic GND	
14	Analog Output	Configurable Analog Output	Motor Speed
15		Electronic GND	
16		Power supply +24 VDC, max. 60mA (total, terminals 16 and 19)	
17	Analog Input 3	Configurable Analog Input 3	Not used
18		Electronic GND	
19		Power supply +24 VDC, max. 60mA (total, terminals 16 and 19)	
20	Analog Input 4	Configurable Analog Input 4	Not used
21		Electronic GND	
22	Digital Input 4	Configurable Digital Input 4, +24 VDC internal pull-up, 6mA contact current	Not used
23		Electronic GND	
24	Digital Input 5	Configurable Digital Input 5, +24 VDC internal pull-up, 6mA contact current	Not used
25		Electronic GND	
26	10 VDC supply	Power supply +10 VDC, max. 3mA	-
27		Electronic GND	
28	Communication bus 1	RS485 port 1: RS485-1B N (-)	Multipump
29		RS485 port 1: RS485-1A P (+)	
30		RS485 port 1: RS485-COM	
31	Communication bus 2	RS485 port 2: RS485-2B N (-)	Modbus
32		RS485 port 2: RS485-2A P (+)	
33		RS485 port 2: RS485-COM	
34	Communication bus 1	RS485 port 1: RS485-1B N (-)	Multipump
35		RS485 port 1: RS485-1A P (+)	
36		RS485 port 1: RS485-COM	
37	Communication bus 2	RS485 port 2: RS485-2B N (-)	Modbus
38		RS485 port 2: RS485-2A P (+)	
39		RS485 port 2: RS485-COM	
40	Relay 1	Configurable relay 1: Normally Open	Running
41		Configurable relay 1: Normally Closed	
42		Configurable relay 1: Common Contact	
43	Relay 2	Configurable relay 2: Normally Open	Error
44		Configurable relay 2: Normally Closed	
45		Configurable relay 2: Common Contact	

Commercial Water

e-HMX SERIES HOW TO READ SMART PUMP SERIES CURVES

To exploit to the maximum potential of Smart Pumps it's important to properly read working curves:

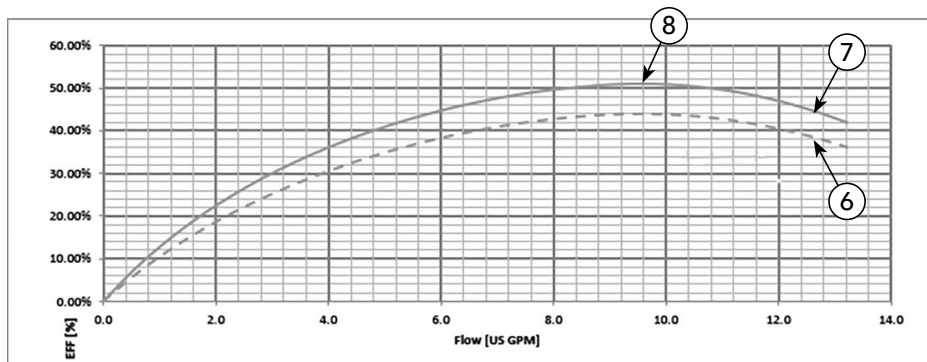
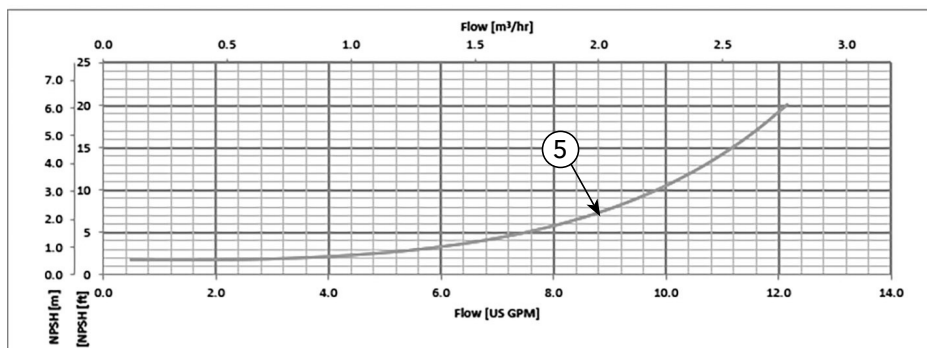
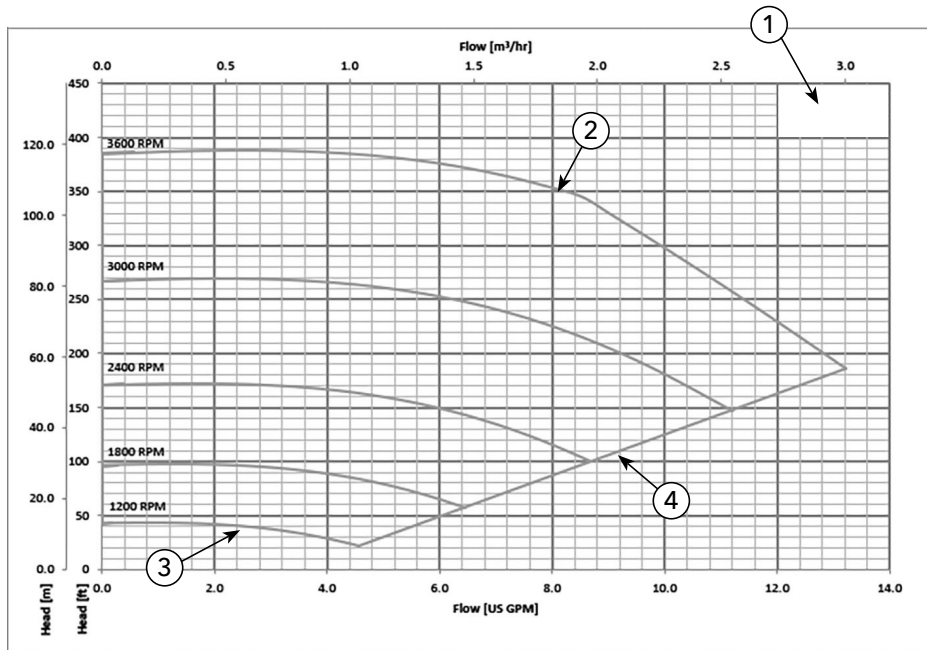

- ① **Pump model**
- ② **Maximum speed curve:** equal to 3600 rpm
- ③ **Minimum speed curve:** Minimum speed curve: the minimum operating speed of the pump and motor. In this example, 1200 RPM
- ④ **Intermediate curves:** hydraulic curves that represent operating conditions at a given speed
- ⑤ **NPSH:** is the net positive suction head of pump+motor+drive system working at maximum speed
- ⑥ **Wire to Water Efficiency:** the net efficiency of the pump, motor, and drive operating at maximum speed
- ⑦ **Pump Efficiency:** the hydraulic efficiency of the pump operating at maximum speed
- ⑧ **Working point:** it's important to make sure the pump is working at the best working point, the one at highest efficiency

It's easy to find it: it's the highest point of the hp pump efficiency curve; once you found it, you can read flow values from x-axis and head values from y-axis which allow the system to work at the best working point

The performances are valid for liquid with density $\rho = 1 \text{ Kg/dm}^3$ and kinematic viscosity $\nu = 1 \text{ mm}^2/\text{sec}$.

3HMX14 Hydraulic Performance

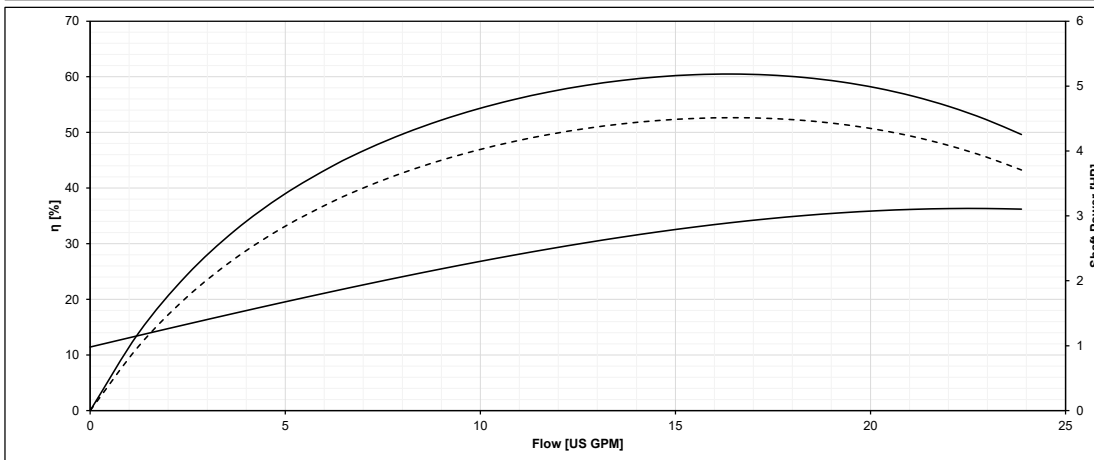
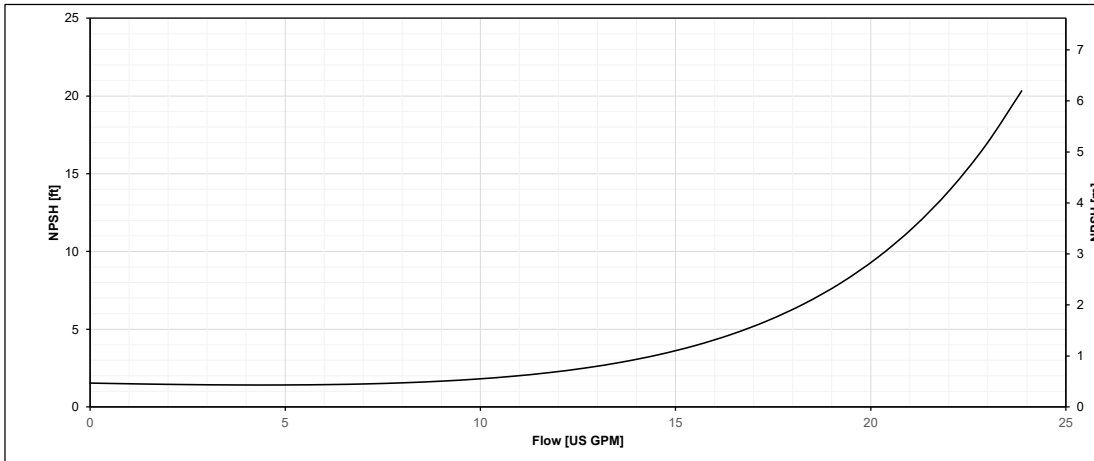
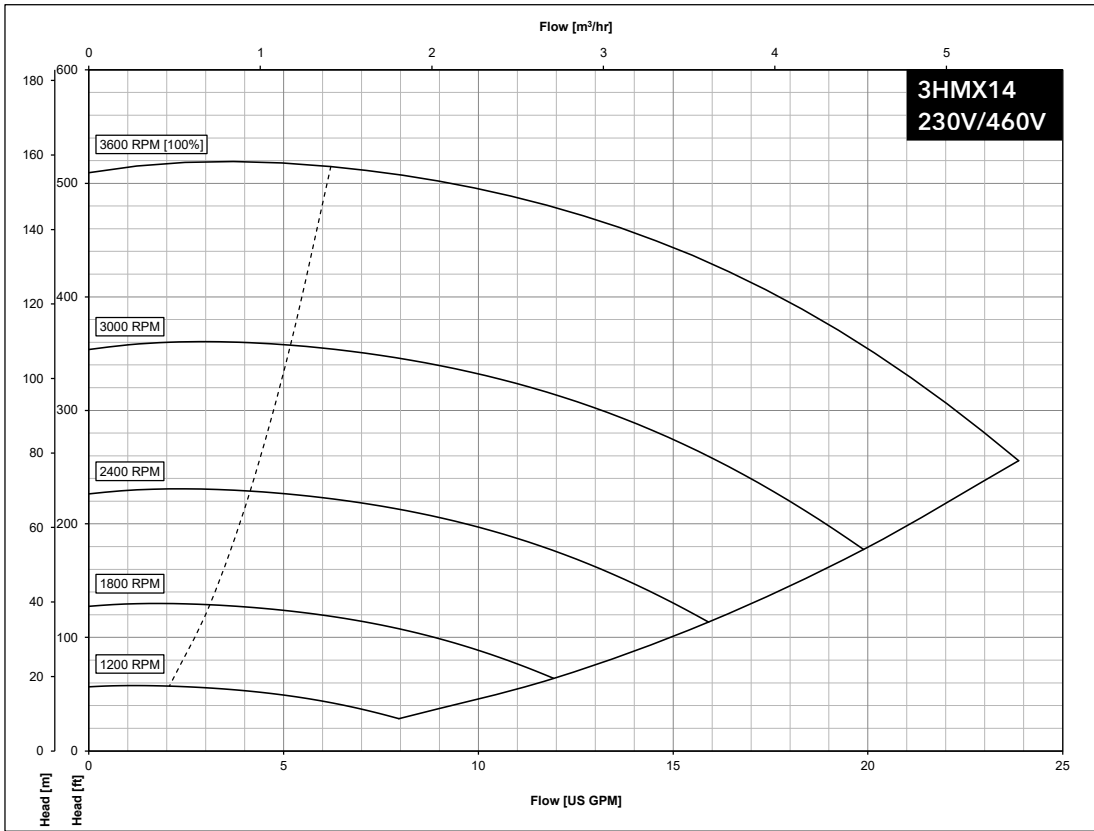

5HMX09 Hydraulic Performance

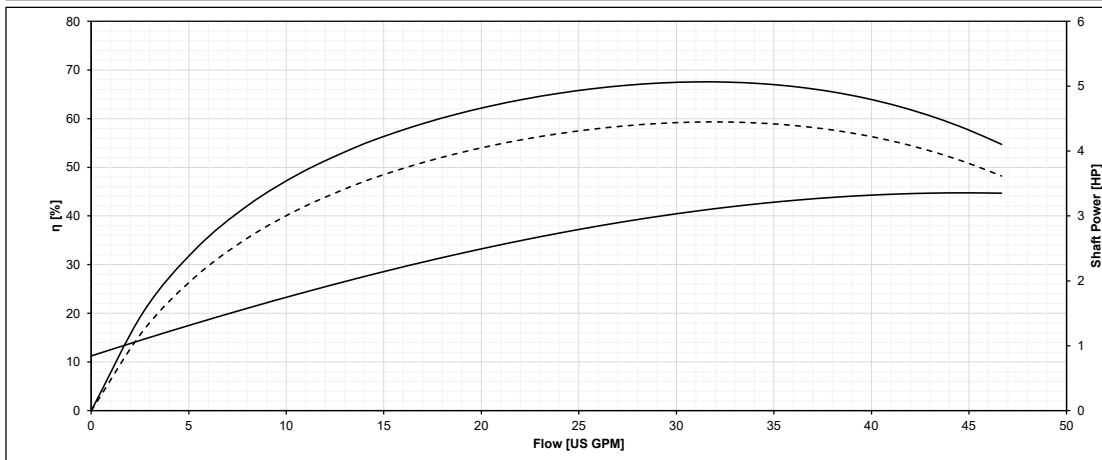
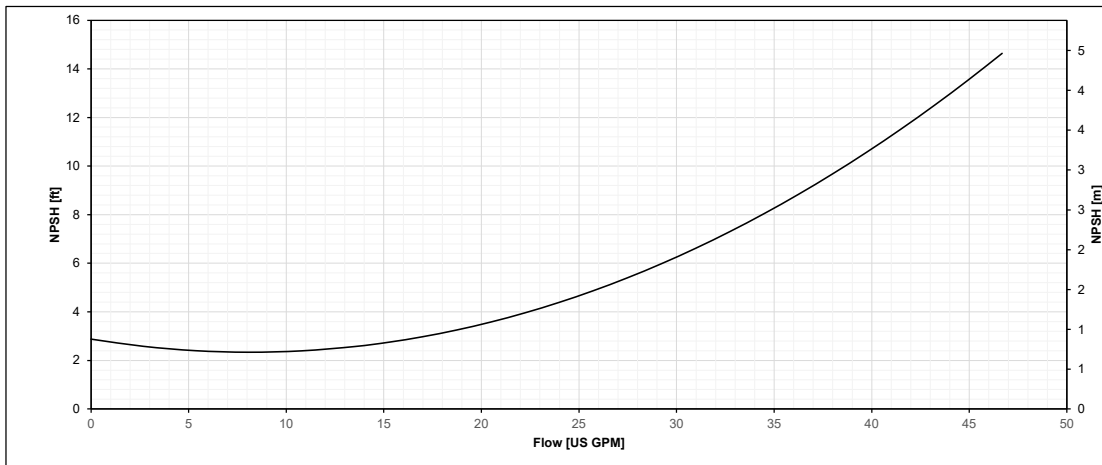
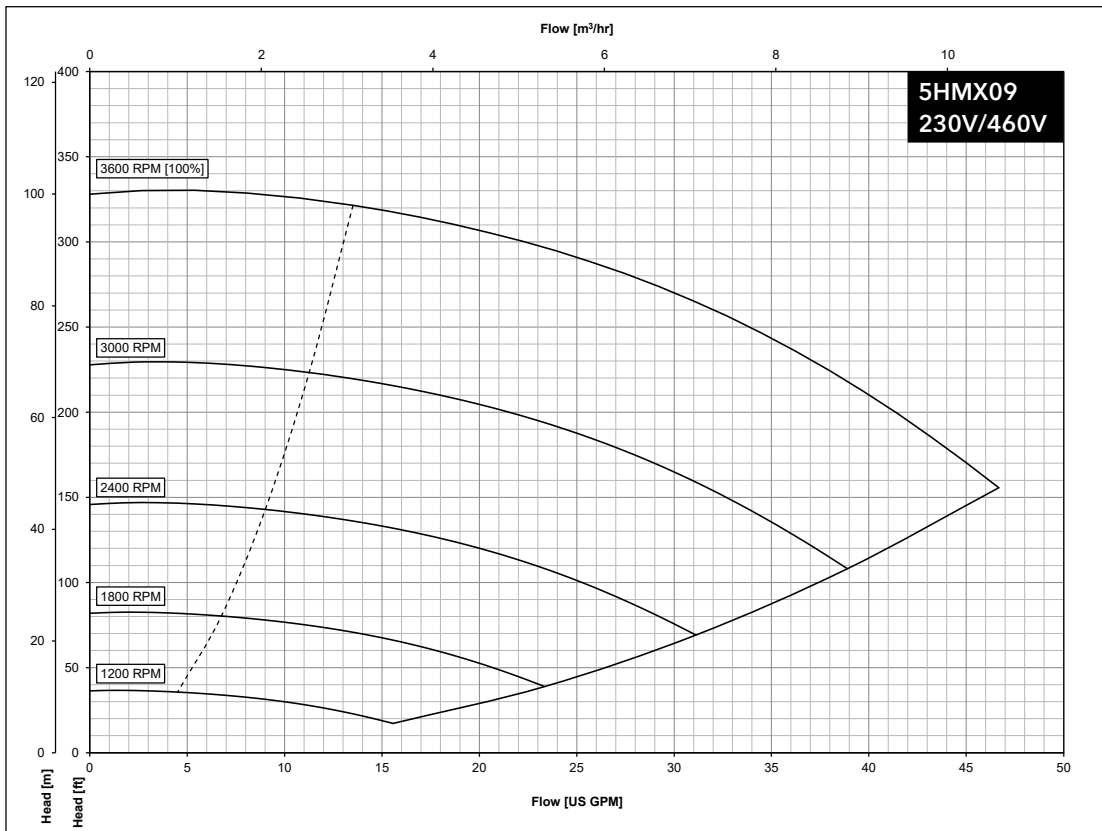

5HMX12 Hydraulic Performance

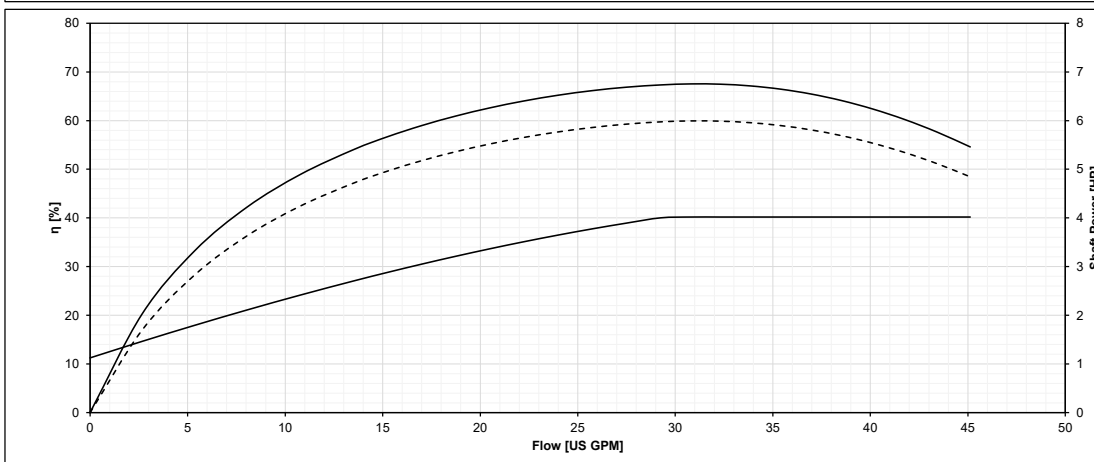
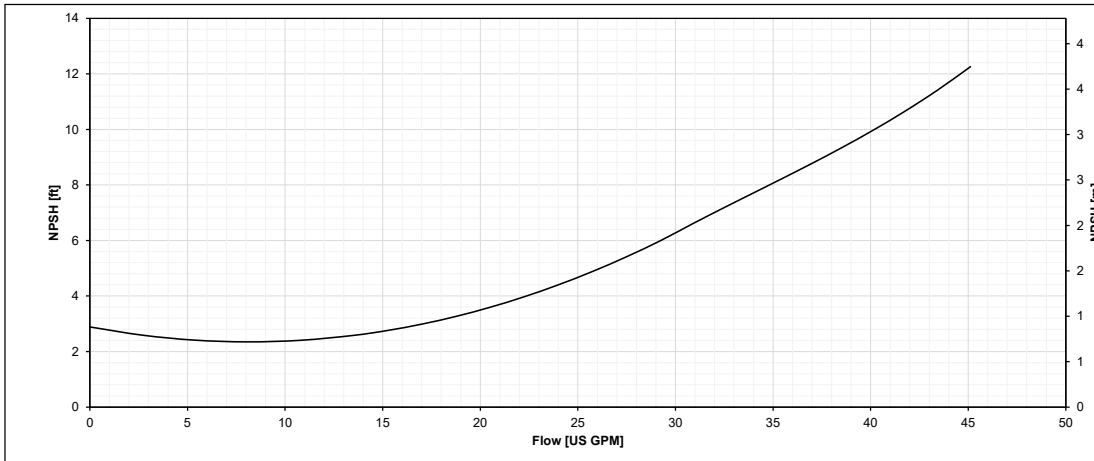
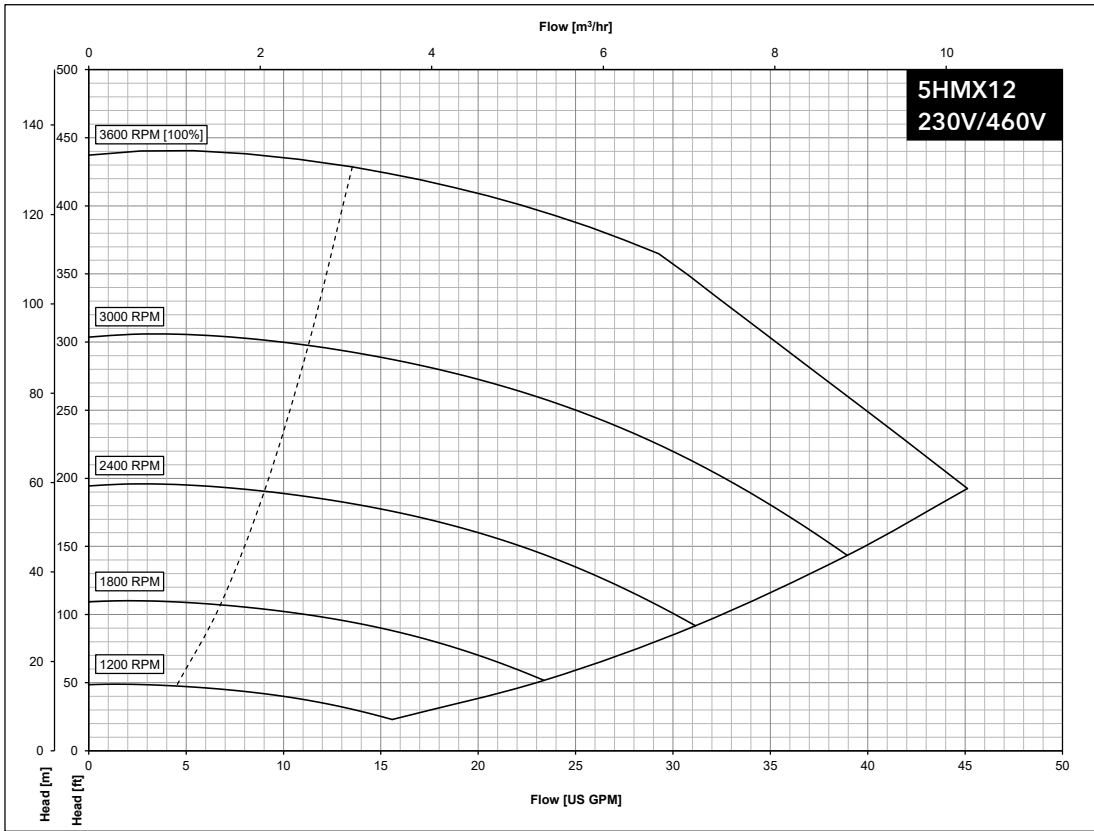

10HMX04 Hydraulic Performance

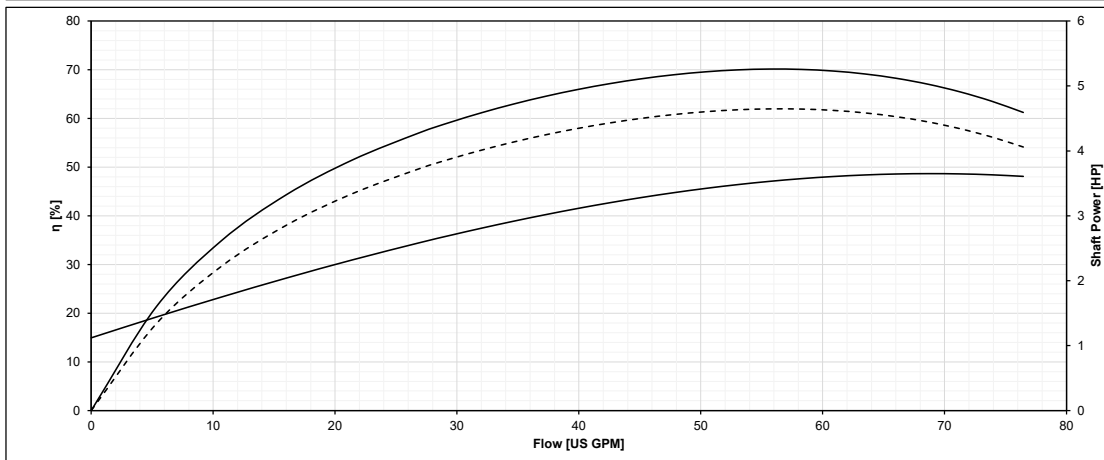
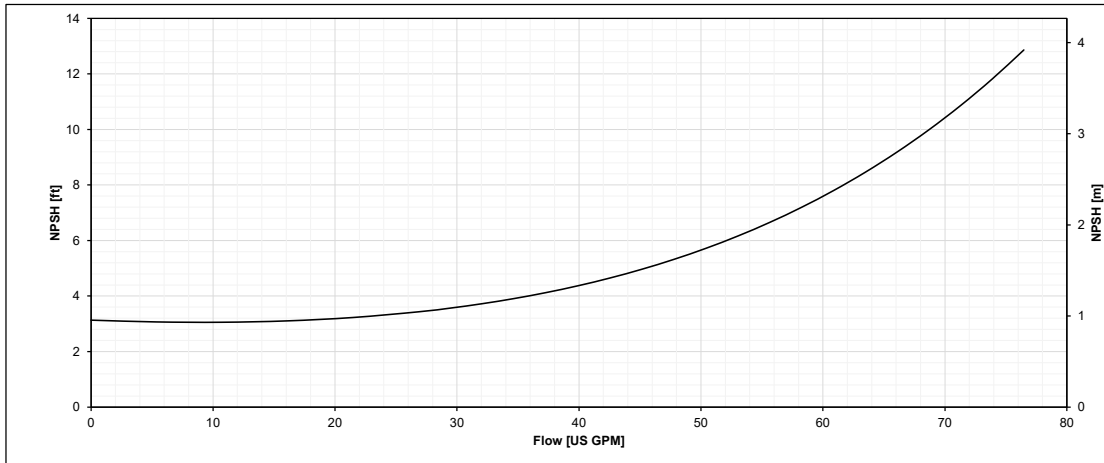
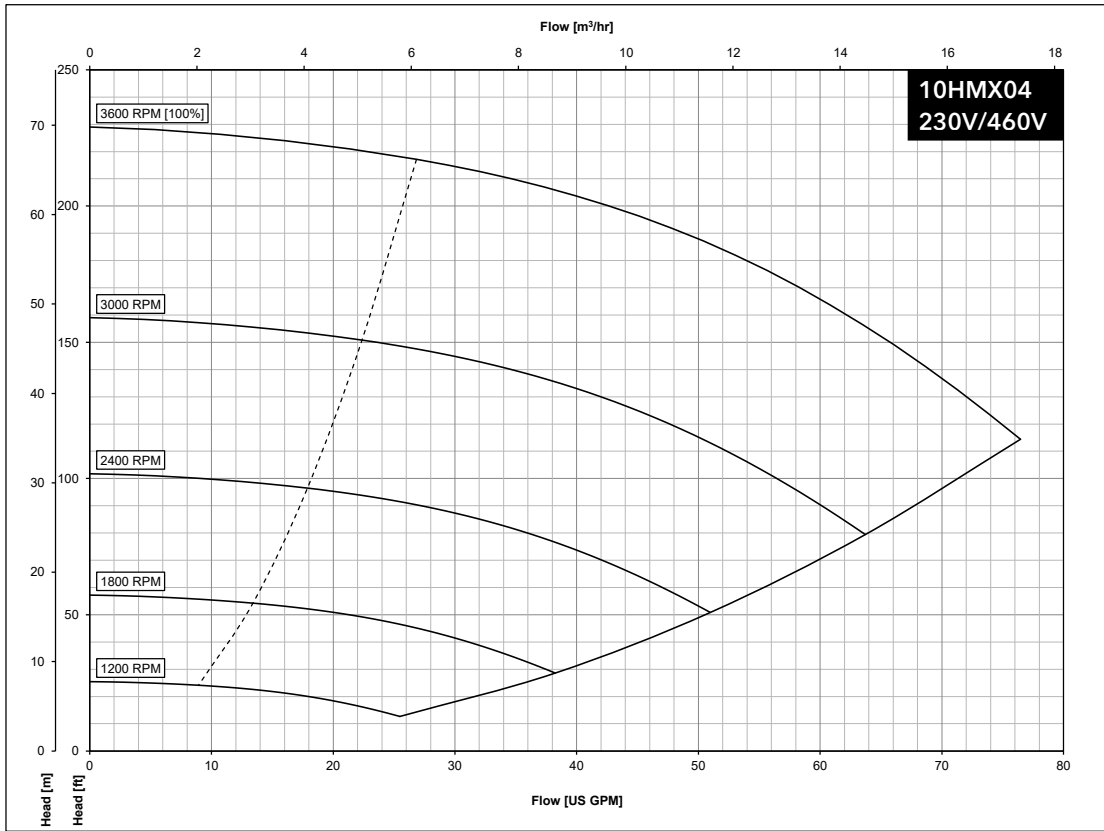

10HMX05 Hydraulic Performance

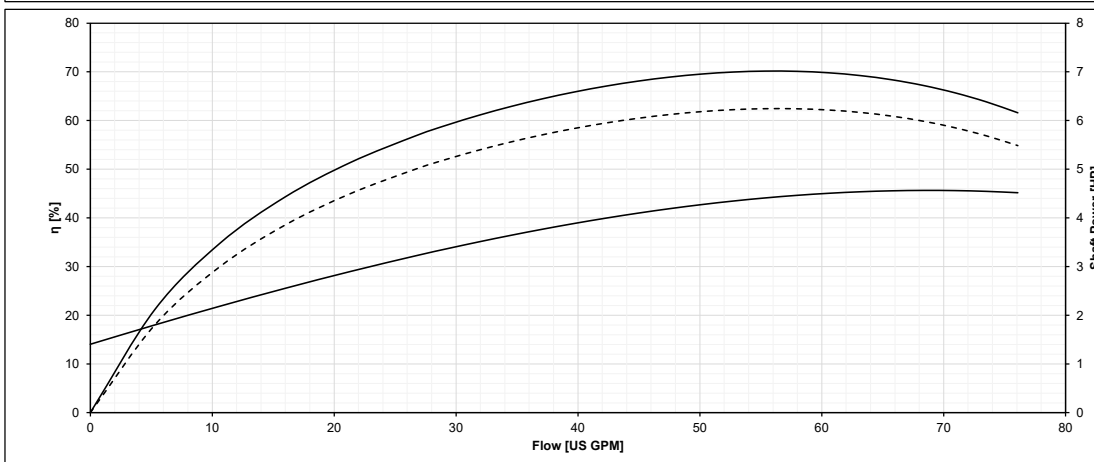
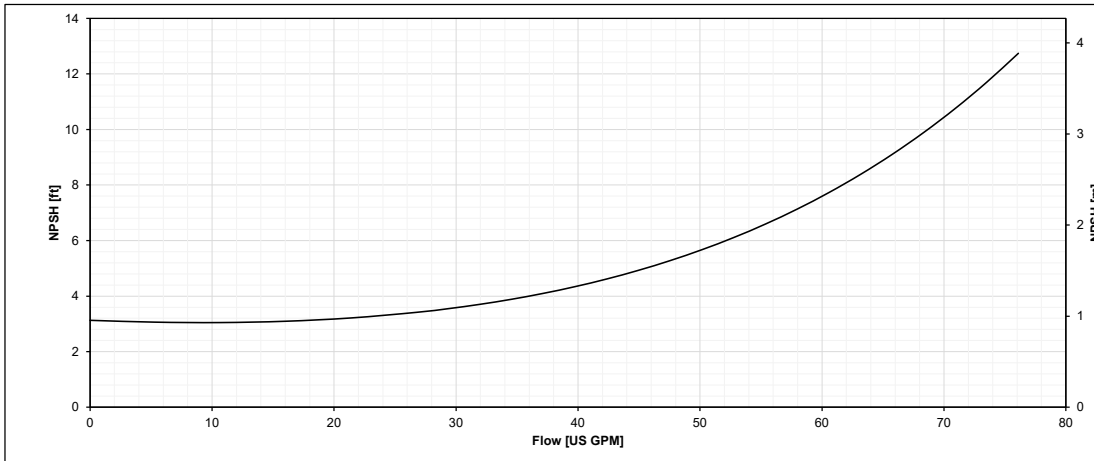
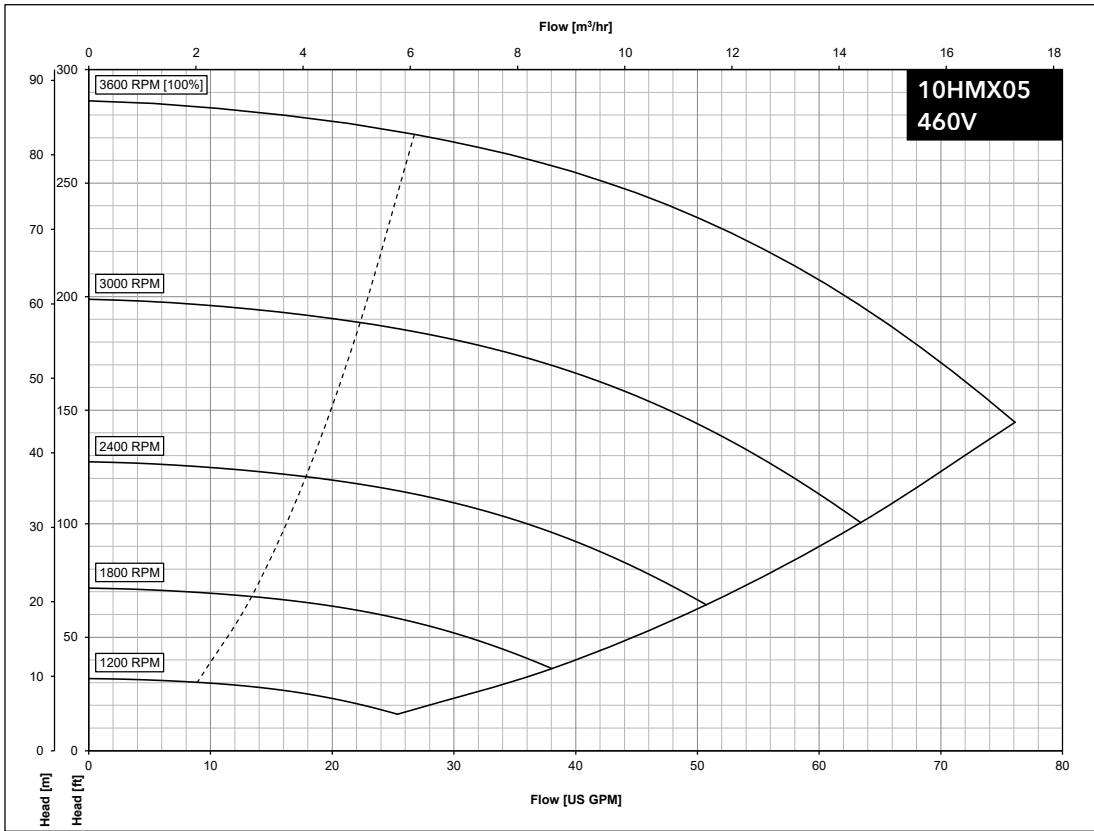

10HMX08 Hydraulic Performance

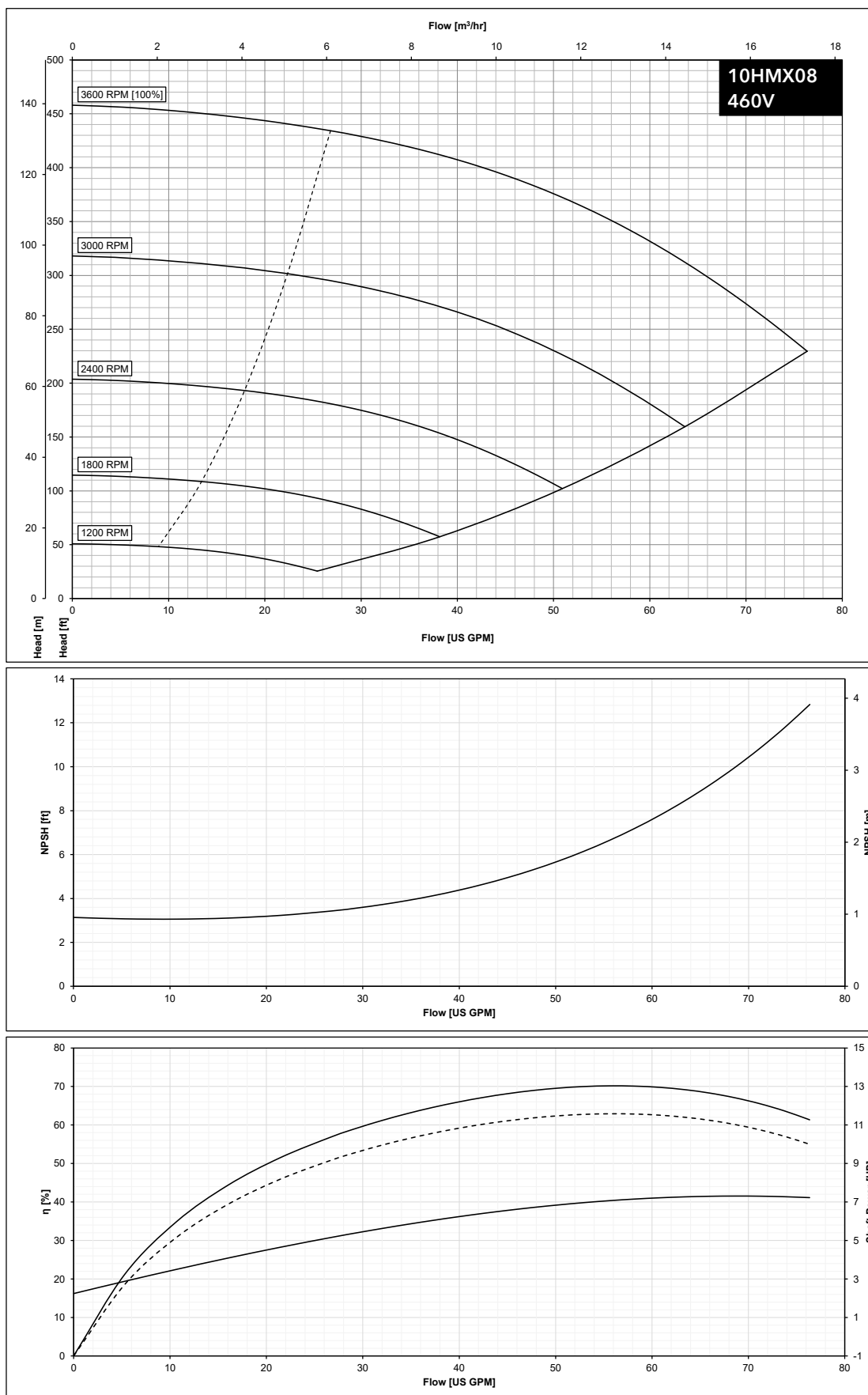

15HMx02 Hydraulic Performance

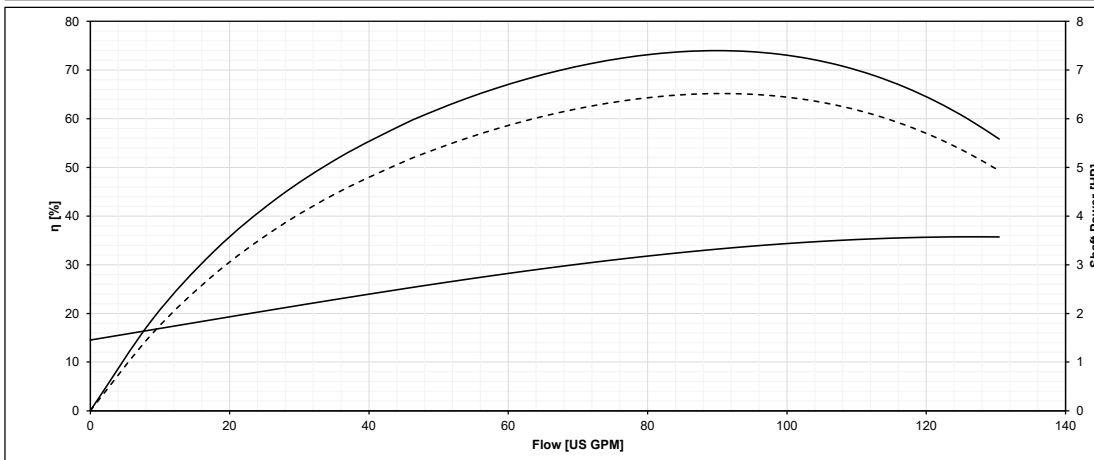
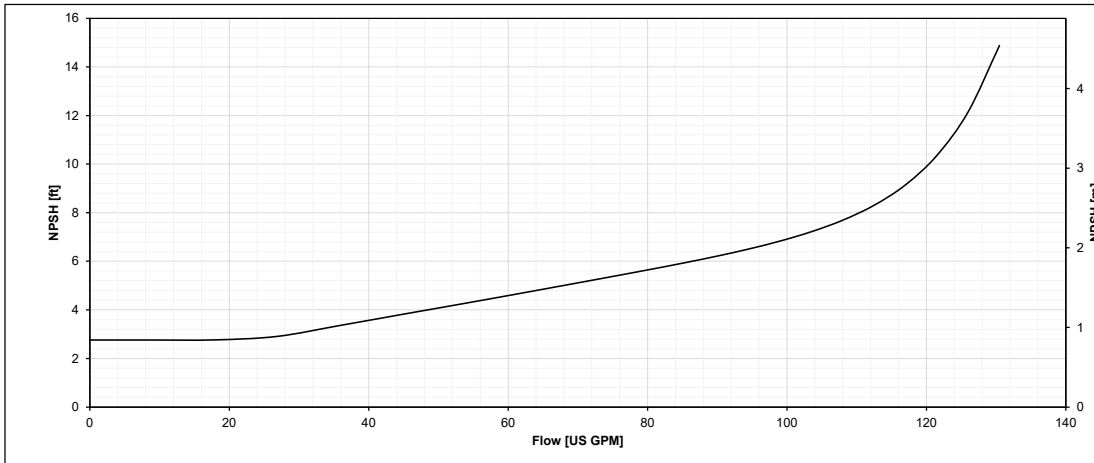
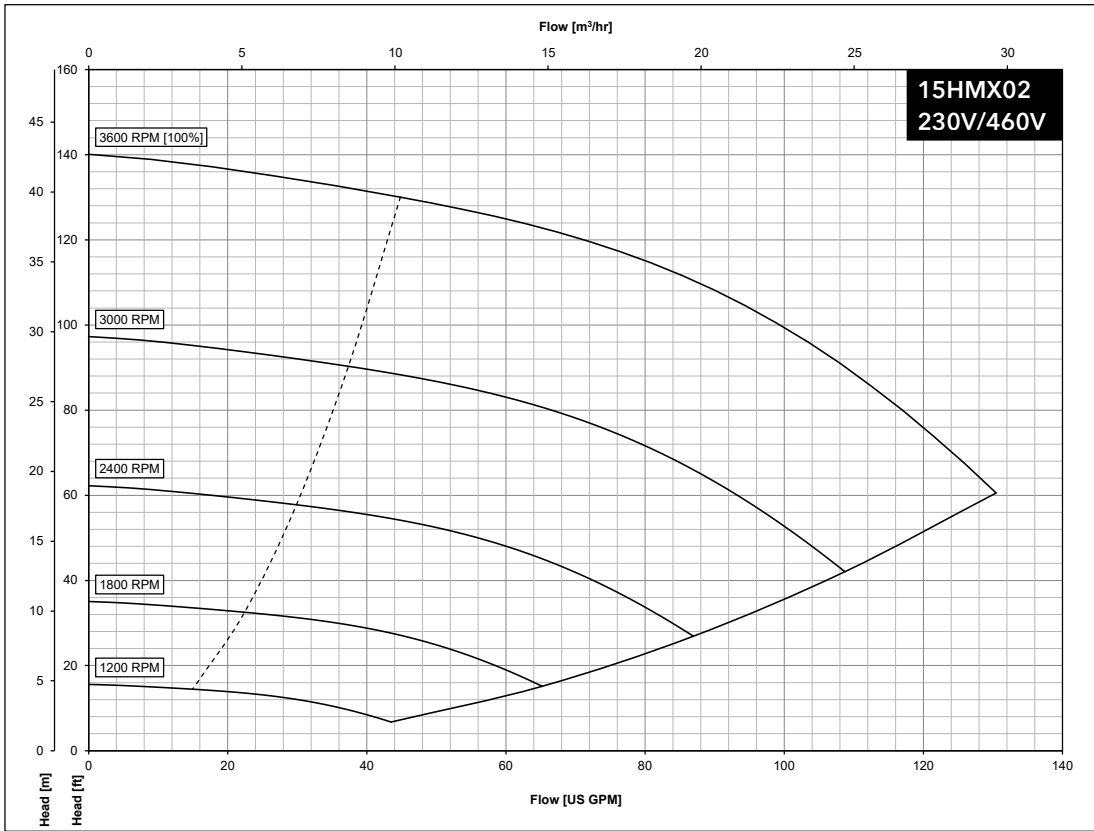

15HMX03 Hydraulic Performance

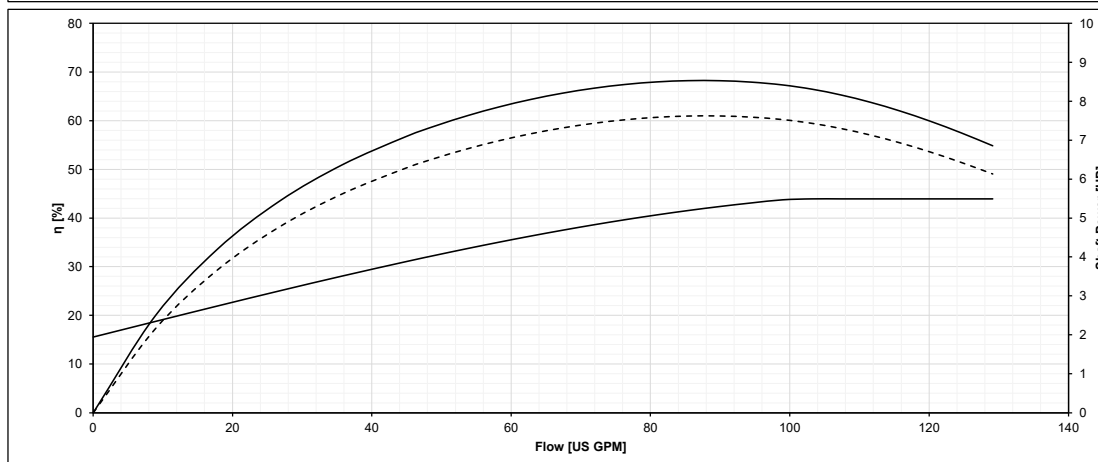
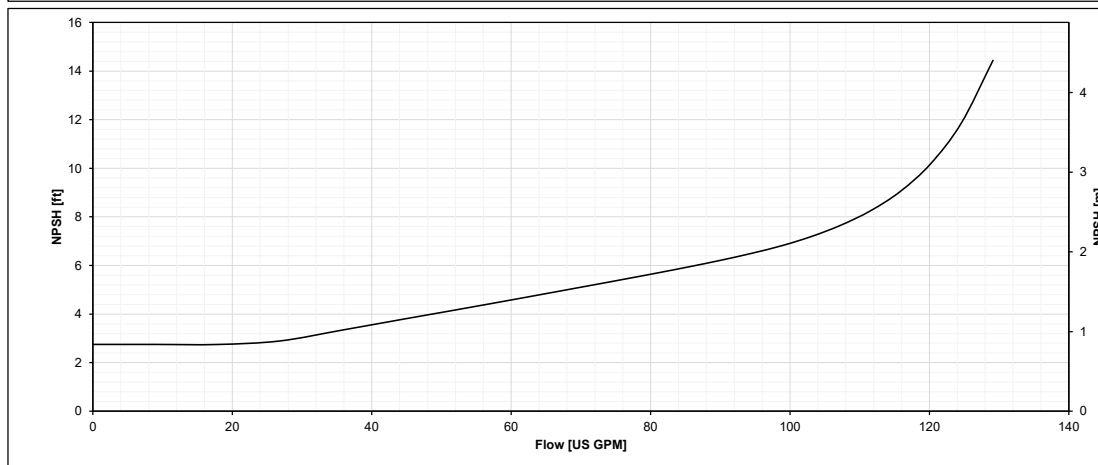
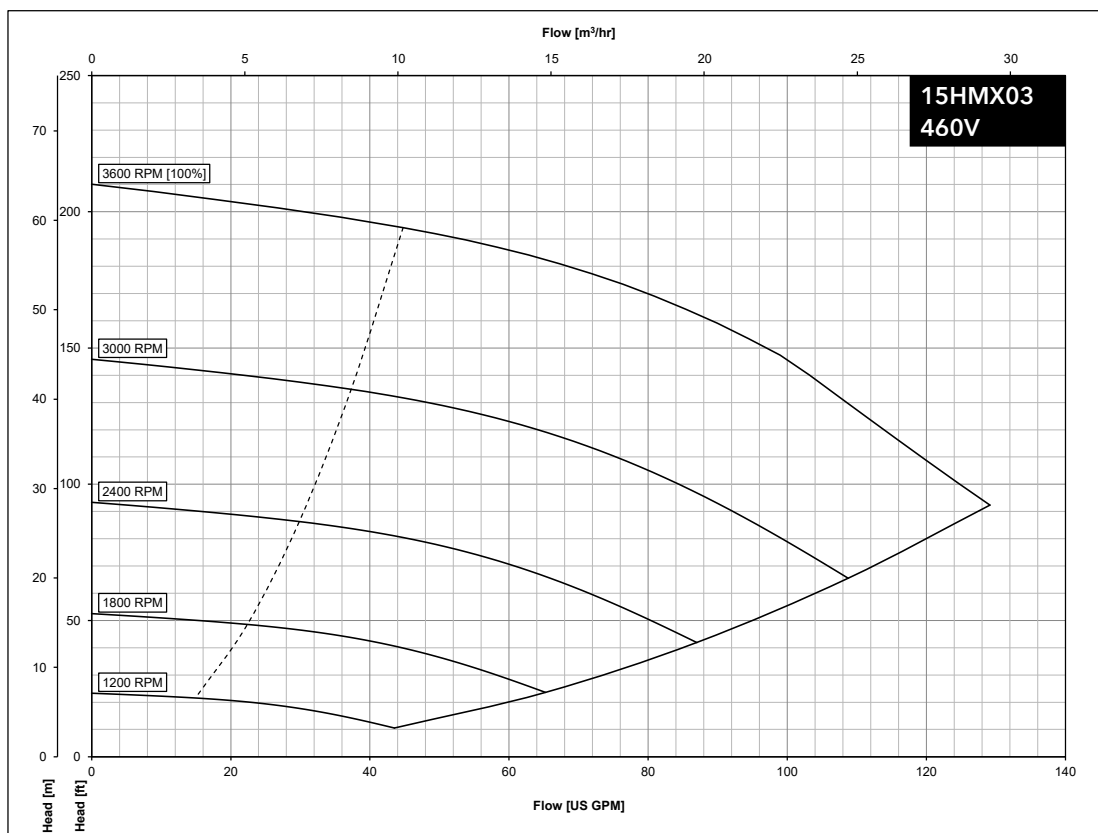

15HMX04 Hydraulic Performance

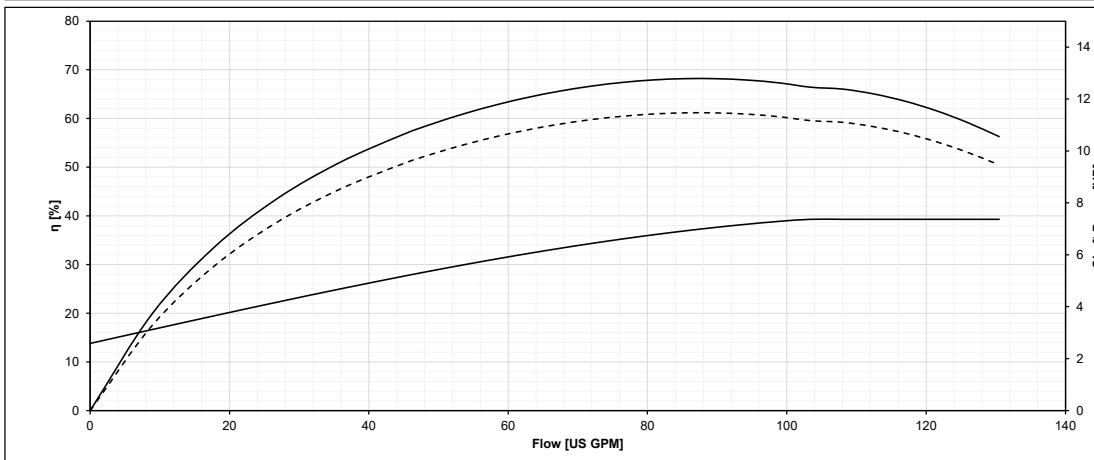
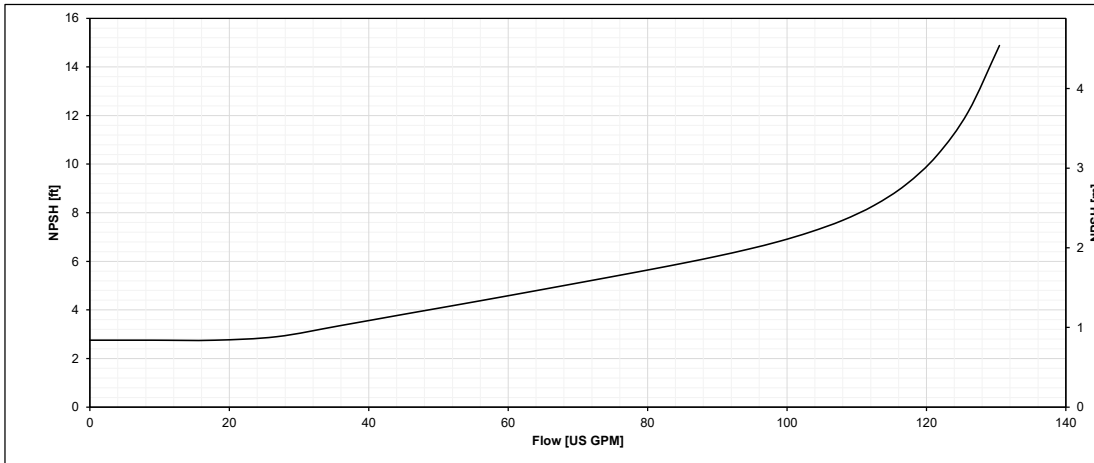
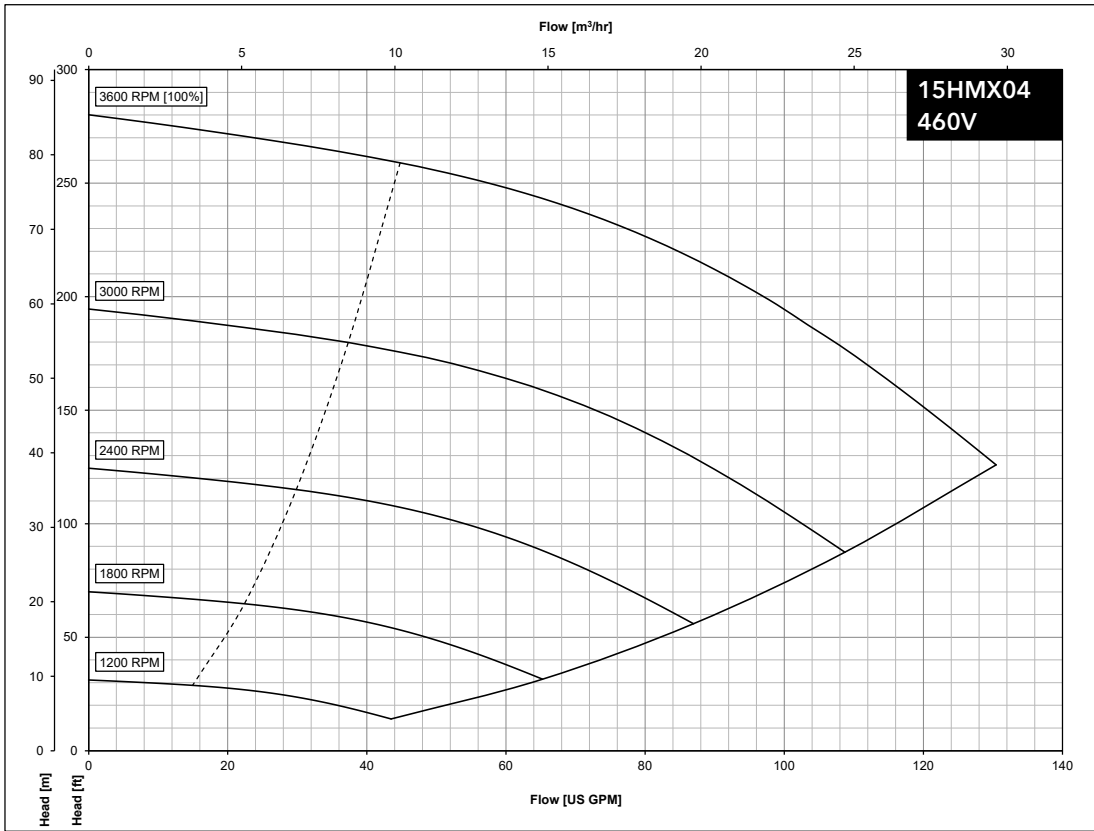

22HMx02 Hydraulic Performance

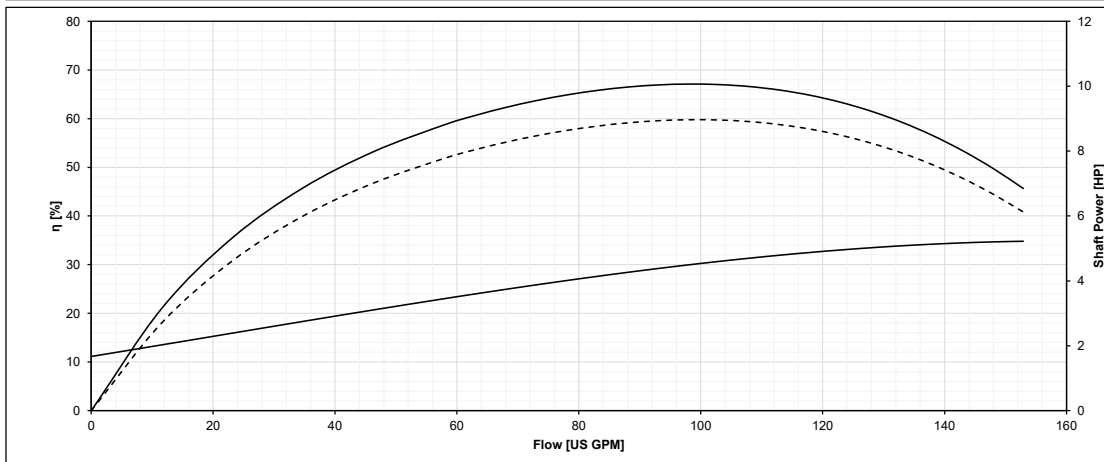
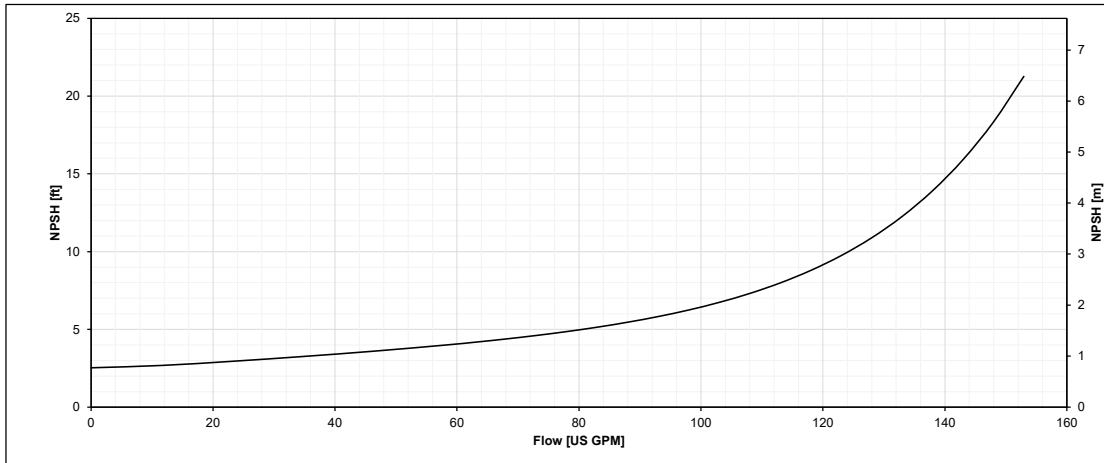
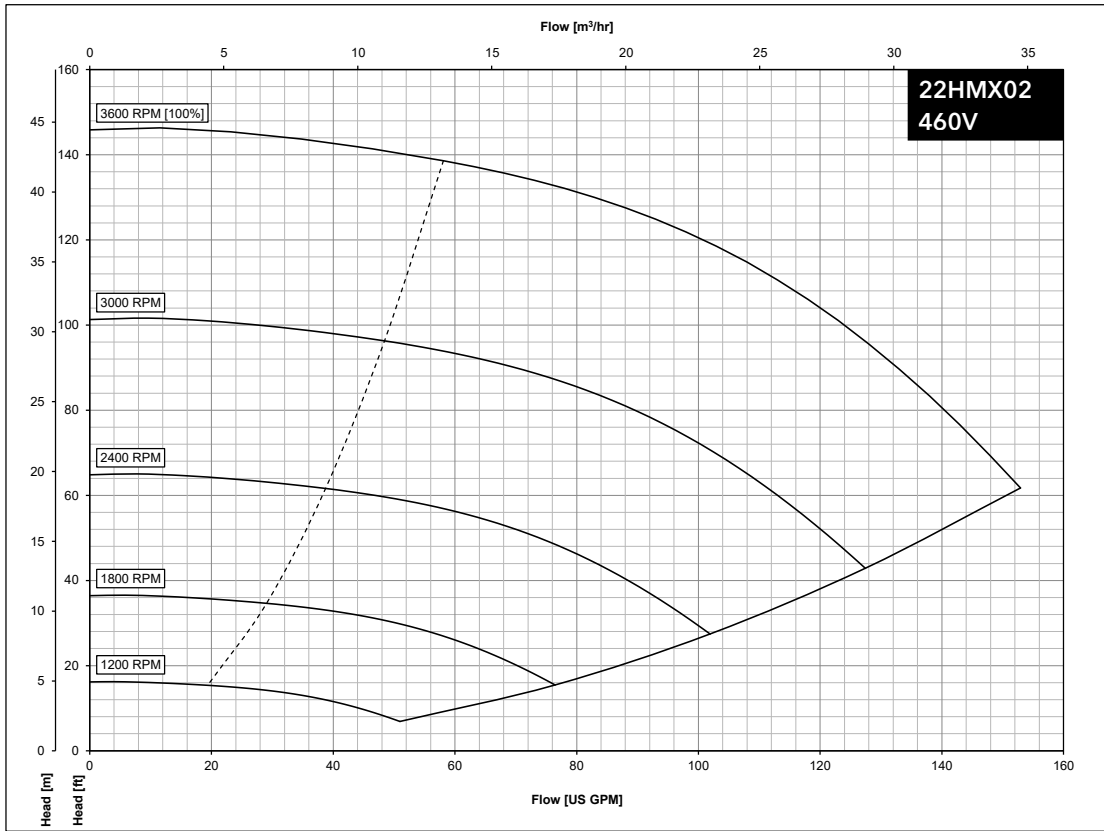

22HMX03 Hydraulic Performance

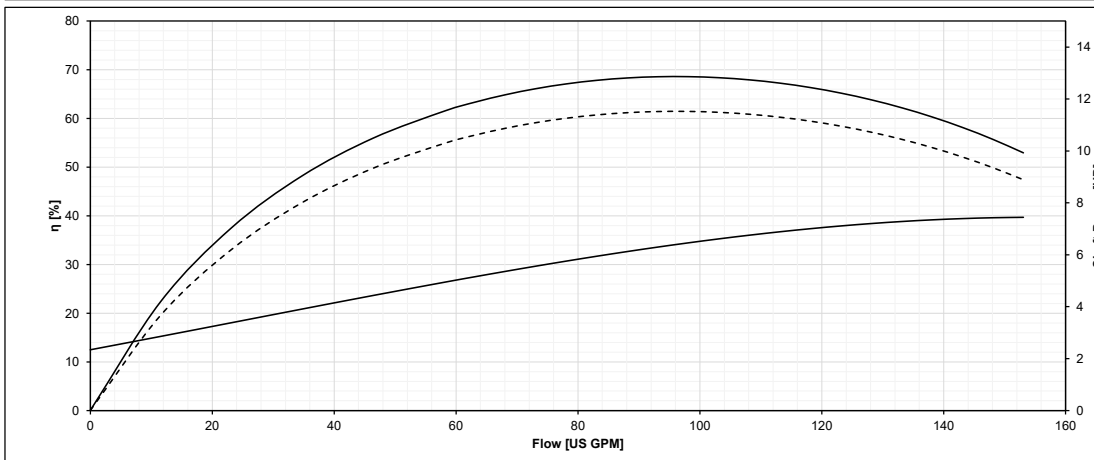
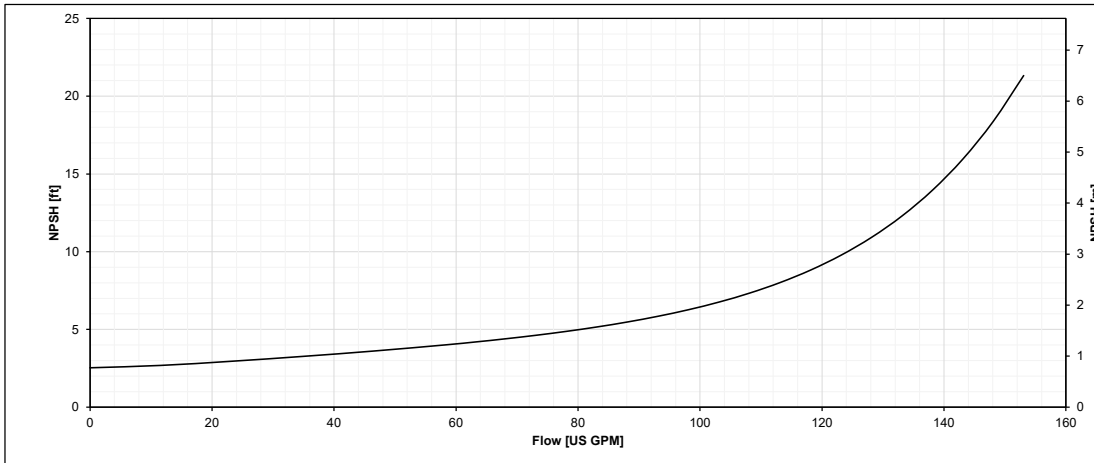
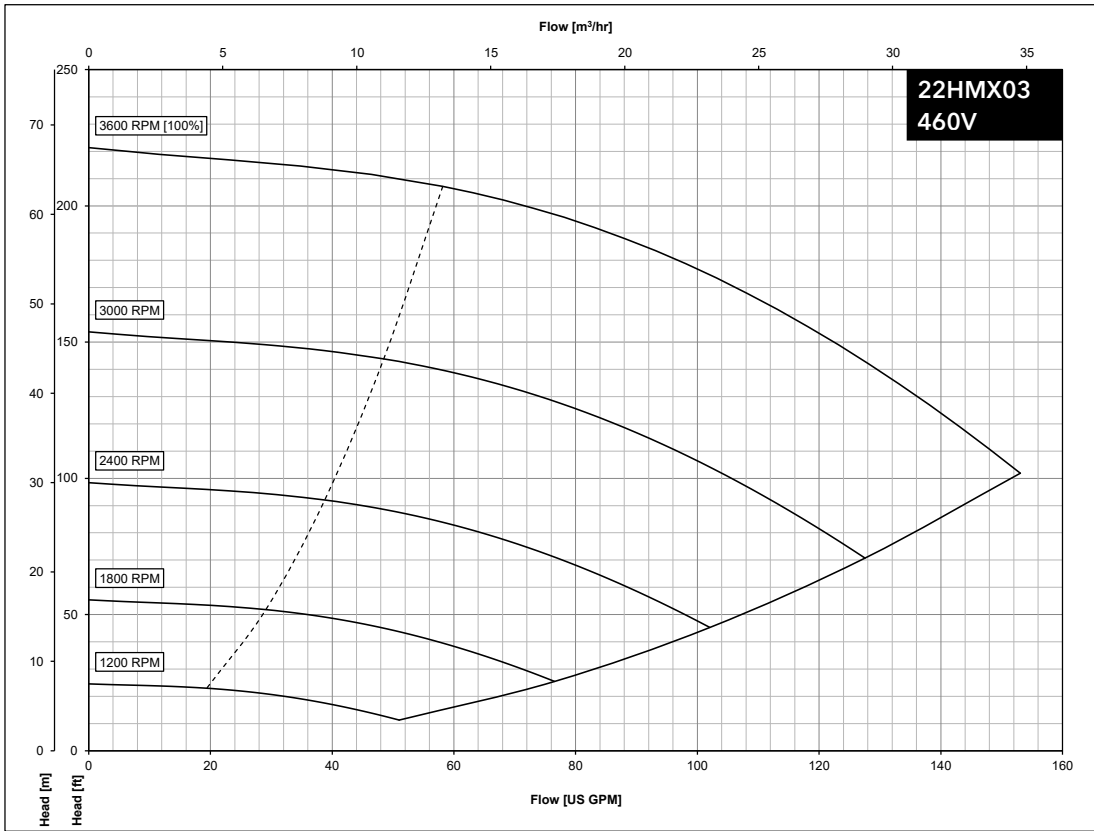

TECHNICAL DATA - WATER PROPERTY CHART

Temp °F	Temp °C	Specific Volume (Cubic ft/lb)	Specific Gravity			Weight (lb/cubic ft)	Vapor Pressure (psi Abs)
			@ 39.2°F	@ 60°F	@ 68°F		
32	0.0	0.01602	1.000	1.001	1.002	62.42	0.088
35	1.7	0.01602	1.000	1.001	1.002	62.42	0.100
40	4.4	0.01602	1.000	1.001	1.002	62.42	0.122
50	10.0	0.01603	0.999	1.001	1.002	62.38	0.178
60	15.6	0.01604	0.999	1.000	1.001	62.34	0.256
70	21.1	0.01606	0.998	0.999	1.000	62.27	0.363
80	26.7	0.01608	0.996	0.998	0.999	62.19	0.507
90	32.2	0.0161	0.995	0.996	0.997	62.11	0.698
100	37.8	0.01613	0.993	0.994	0.995	62.00	0.949
120	48.9	0.0162	0.989	0.990	0.991	61.73	1.692
140	60.0	0.01629	0.983	0.985	0.986	61.39	2.889
160	71.1	0.01639	0.977	0.979	0.979	61.01	4.741
180	82.2	0.01651	0.970	0.972	0.973	60.57	7.510
200	93.3	0.01663	0.963	0.964	0.966	60.13	11.526
212	100.0	0.01672	0.958	0.959	0.960	59.81	14.696
220	104.4	0.01677	0.955	0.956	0.957	59.63	17.186
240	115.6	0.01692	0.947	0.948	0.949	59.10	24.97
260	126.7	0.01709	0.938	0.939	0.940	58.51	35.43
280	137.8	0.01726	0.928	0.929	0.930	58.00	49.20
300	148.9	0.01745	0.918	0.919	0.920	57.31	67.01
320	160.0	0.01756	0.908	0.909	0.910	56.66	89.66
340	171.1	0.01787	0.896	0.898	0.899	55.96	118.01
360	182.2	0.01811	0.885	0.886	0.887	55.22	153.04
380	193.3	0.01836	0.873	0.874	0.875	54.47	195.77
400	204.4	0.01864	0.859	0.860	0.862	53.65	247.31
420	215.6	0.01894	0.846	0.847	0.848	52.80	308.83
440	226.7	0.01926	0.832	0.833	0.834	51.92	381.59
460	237.8	0.0196	0.817	0.818	0.819	51.02	466.9
480	248.9	0.02	0.801	0.802	0.803	50.00	566.1
500	260.0	0.0204	0.785	0.786	0.787	49.02	680.8
520	271.1	0.0209	0.765	0.766	0.767	47.85	812.4
540	282.2	0.0215	0.746	0.747	0.748	46.51	962.5
560	293.3	0.0221	0.726	0.727	0.728	45.30	1133.1
580	304.4	0.0228	0.703	0.704	0.704	43.90	1325.8
600	315.6	0.0236	0.678	0.679	0.680	42.30	1542.9
620	326.7	0.0247	0.649	0.650	0.650	40.50	1786.6
640	337.8	0.026	0.617	0.618	0.618	38.50	2059.7
660	348.9	0.0278	0.577	0.577	0.578	36.00	2365.4
680	360.0	0.0305	0.525	0.526	0.527	32.80	2708.1
700	371.1	0.0369	0.434	0.435	0.435	27.10	3093.7

TECHNICAL DATA - COMPATABILITY CHART FOR MATERIALS IN CONTACT WITH MOST COMMONLY USED LIQUIDS

Liquid	Concentration (%)	Temperature Min/Max °F	Specific Weight (lb/in³)	1HM - 22HM	Recommended Seal	Elastomers
				316		
Water	100	23/248		•	QBEGG	E
Deionized, demineralized	100	-13/230		•	QBEGG	E
Water and oil emulsion	any	23/194		•	QBVGG	V
Acetic acid (•)	80	14/158	.038	•	QBEGG	E
Citric acid	5	14/158	.056	•	QBEGG	E
Hydrochloric acid	2	23/77	.043	•	QQVGG	V
Phosphoric acid	10	23/86	.048	•	QBEGG	E
Nitric acid (•)	50	23/86	.053	•	QQVGG	V
Sulphuric acid (•)	2	14/77	.066	•	QBVGG	V
Tannic acid	20	32/122		•	QBEGG	E
Tartaric acid	50	14/77	.063	•	QQVGG	V
Uric acid	80	14/176	.068	•	QBEGG	E
Benzoic acid	70	32/158	.047	•	QBVGG	V
Boric acid	Saturated	14/194	.052	•	QQVGG	V
Formic acid (•)	5	5/77	.044	•	QBEGG	E
Ethyl alcohol (•)	100	23/104	.029	•	QBEGG	E
Methyl alcohol (•)	100	23/104	.029	•	QBEGG	E
Propyl alcohol (•)	100	23/176	.029	•	QBEGG	E
Butyl alcohol	100	23/176	.030	•	QBVGG	V
Denatured alcohol (•)	100	23/158	.030	•	QBEGG	E
Ammonia in water (•)	25	-4/122	.038	•	QBEGG	E
Chloroform		14/86	.053	•	QBVGG	V
Caustic soda	25	32/158	.077	•	QQEGG	E
Water, detergents,		23/176		•	QQVGG	V
Cleaning products		23/212		•	QQVGG	V
Diesel oil (•)	100	32/176	.033	•	QBVGG	V
Kerosene (•)	100	32/176		•	QBVGG	V
Fuel oil (•)		32/194	.027	•	QBVGG	V
Glycerine	100	68/194	.046	•	QBEGG	E
Sodium Hypochlorite	1	14/77		•	QQVGG	V
Phosphates/polyphosphates		23/194		•	QQVGG	V
Sodium nitrate	Saturated	14/176	.081	•	QBEGG	E
Cutting fluid	100	23/230	.033	•	QBVGG	V
Peanut oil (•)	100	23/230	.034	•	QBEGG	E
Colza oil (•)	100	23/230	.034	•	QBEGG	E
Linseed oil (•)	100	23/230	.034	•	QBEGG	E
Coconut oil (•)	100	-4/194	.033	•	QBEGG	E
Soybean oil (•)	100	32/194		•	QBEGG	E
Diathermic oil	100	23/230	.033	•	QBVGG	V
Hydraulic oil	100	23/230		•	QBVGG	V
Mineral oil	100	23/230	.034	•	QBVGG	V
Sodium sulfate	15	14/104	.094	•	QQEGG	E
Aluminum sulfate	30	23/122	.097	•	QQEGG	E
Ammonium sulfate	10	14/140	.064	•	QQEGG	E
Iron sulfate	10	23/86	.076	•	QBEGG	E
Copper sulfate	20	32/86	.082	•	QQVGG	V
Trichloroethylene		14/104	.053	•	QBVGG	V
Perchloroethylene		14/86	.057	•	QBVGG	V

Legend

Q = Silicon carbide B = Carbon E = EPDM V = Viton G = AISI 316 (spring, metal components)

(•) A special version may be necessary for this fluid. For additional information, please contact our sales network.

Commercial Water

TECHNICAL DATA - NPSH

NPSH

The minimum operating values that can be reached at the pump suction end are limited by the onset of cavitation.

Cavitation is the formation of vapor-filled cavities within liquids where the pressure is locally reduced to a critical value, or where the local pressure is equal to, or just below the vapor pressure of the liquid.

The vapor-filled cavities flow with the current and when they reach a higher pressure the vapor contained in the cavities condenses. The cavities collide, generating pressure waves that are transmitted to the walls. These, being subjected to stress cycles, gradually become deformed and yield due to fatigue. This phenomenon, characterized by a metallic noise produced by the hammering on the pipe walls, is called incipient cavitation.

The damage caused by cavitation may be magnified by electrochemical corrosion and a local rise in temperature due to the plastic deformation of the walls. The materials that offer the highest resistance to heat and corrosion are alloy steels, especially austenitic steel. The conditions that trigger cavitation may be assessed by calculating the total net suction head, referred to in technical literature with the acronym NPSH (Net Positive Suction Head).

The NPSH represents the total energy (expressed in feet) of the liquid measured at suction under conditions of incipient cavitation, excluding the vapor pressure (expressed in feet) that the liquid has at the pump inlet.

To find the static height (h_z) at which to install the machine under safe conditions, the following formula must be verified:

$$h_p + h_z \geq (\text{NPSHr} + 2 \text{ ft}) + h_f + h_{pv}$$

where:

h_p is the absolute pressure applied to the free liquid surface in the suction tank, expressed in feet of liquid; h_p is the quotient between the barometric pressure and the specific weight of the liquid.

h_z is the suction lift between the pump axis and the free liquid surface in the suction tank, expressed in feet; h_z is negative when the liquid level is lower than the pump axis.

h_f is the flow resistance in the suction line and its accessories, such as: fittings, foot valve, gate valve, elbows, etc.

h_{pv} is the vapor pressure of the liquid at the operating temperature, expressed in feet of the liquid. h_{pv} is the quotient between the P_v vapor pressure and the liquid's specific weight.

0.5 is the safety factor.

The maximum possible suction head for installation depends on the value of the atmospheric pressure (i.e. the elevation above sea level at which the pump is installed) and the temperature of the liquid.

To help the user, with reference to water temperature (40°F) and to the elevation above sea level, the following tables show the drop in hydraulic pressure head in relation to the elevation above sea level, and the suction loss in relation to temperature.

Water Temperature (°F)	68	104	140	176	194	230	248
Suction Loss (ft)	-0.7	2.3	6.6	16.4	24.3	50.5	70.5

Elevation Above Sea Level (ft)	1600	3300	4900	6500	8200	9800
Suction Loss (ft)	1.8	3.6	5.4	7.2	9.0	10.8

To reduce it to a minimum, especially in cases of high suction head (over 13 - 16 feet) or within the operating limits with high flow rates, we recommend using a suction line having a larger diameter than that of the pump's suction port. It is always a good idea to position the pump as close as possible to the liquid to be pumped.

Xylem |'zīləm|

- 1) The tissue in plants that brings water upward from the roots;
- 2) a leading global water technology company.

We're a global team unified in a common purpose: creating advanced technology solutions to the world's water challenges. Developing new technologies that will improve the way water is used, conserved, and re-used in the future is central to our work. Our products and services move, treat, analyze, monitor and return water to the environment, in public utility, industrial, residential and commercial building services settings. Xylem also provides a leading portfolio of smart metering, network technologies and advanced analytics solutions for water, electric and gas utilities. In more than 150 countries, we have strong, long-standing relationships with customers who know us for our powerful combination of leading product brands and applications expertise with a strong focus on developing comprehensive, sustainable solutions.

For more information on how Xylem can help you, go to www.xylem.com

Learn more about
e-HMX Smart Pumps:



Xylem Product Cybersecurity

Xylem values your system security and the availability of your critical services. For more information on Xylem cybersecurity practices or to contact the cybersecurity team please visit xylem.com/security.



Xylem Inc.
1 Goulds Drive
Auburn, NY 13021
Phone: (866) 673-0428
Fax: (888) 322-5877
www.xylem.com/goulds

Xylem is a registered trademark of Xylem Inc. or one of its subsidiaries. Goulds is a registered trademark of ITT Manufacturing Enterprises LLC and is used under license. All other trademarks or registered trademarks are property of their respective owners.

© 2024 Xylem Inc. GWTe-HMXTB400005 R1 February 2024

Order Online: www.PumpCatalog.com