

Multifunction Valve, Model MFV

For 900/800/400/300 Series
Cartridge Valve Liquid Ends
Quick Start Guide

Manual No.: 57884

Revision : 2

Date : 03/2021



Precautions and Warnings:



Always wear protective clothing, face shield, safety glasses when working on or near your chemical metering pump. Additional precautions should be taken depending on the solution being pumped. Refer to MSDS precautions from chemical supplier.

The relief line must be mechanically fastened to the supply tank.

Use 3/8" tubing only for the relief line.

Maximum rated flow is 8 GPH (30.3 LPH)

Introduction

LMI® Series metering pumps are offered with a multifunction valve, Model MFV. The MFV can be mounted directly on the liquid end of the pump. The features and functions are listed below.

MFV Features:

- Ergonomic design for easy control of functions.
- PVDF body (standard) / PVC body (Pro) and hardware compatible with most chemicals.
- A mounting connection that swivels 360° to the position best suited for installations.
- LMI®'s tubing connection system for the most secure connection available with electronic metering pump.

MFV Functions:-

- **Anti-Syphon:** A diaphragm allows flow only with the discharge stroke of the pump. This prevents the discharge line from syphoning liquid from the supply tank in most application.
- **Back Pressure:** This diaphragm creates approximately 20 psi (1.4 bar) of back pressure. This improves system performance by providing constant pressure against the pump.
- **Pressure Relief:** A second diaphragm protects the pump from overpressure by releasing fluid through a relief port in the event of excessive discharge line pressure.
- **Burp:** Turn the yellow knob to eliminate the valve's back pressure allowing the pump to run at atmospheric pressure.
- **Prime:** Turn the black knob to divert flow through the relief line to the tank. This allows air through flow from the head.
- **Drain Line:** Turn both knobs to open the discharge line to the tank, leaving it open to atmosphere.

Yellow Knob

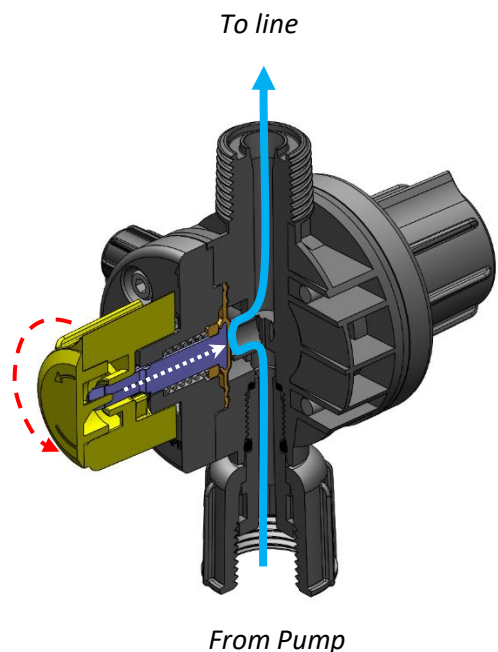

Function	Action
Back-Pressure	Automatic
Anti-Siphon	Automatic
Burp	Turn Yellow

Black Knob

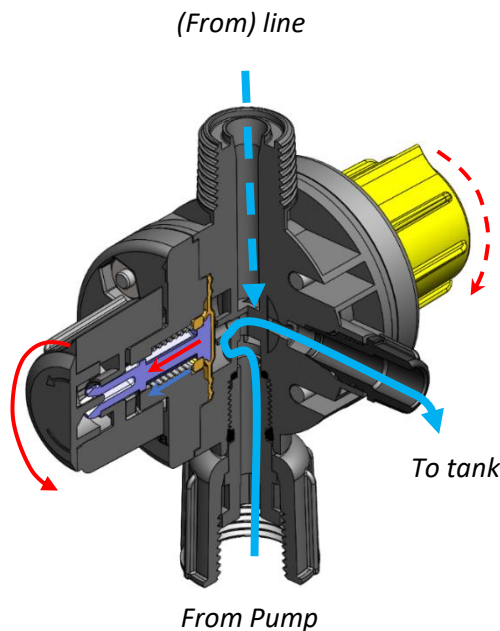

Function	Action
Pressure Relief	Automatic
Prime	Turn Black
Drain Line	Turn B & Y

Multifunction Valve Parts List



Standard Version

Designed for General Applications

Body Material: PVDF

MFV Kit Numbers	Description
57708	MFV Kit, 150 PSI, ½" NPT, Polyprel
57710	MFV Kit, 250 PSI, ½" NPT, Polyprel
57709	MFV Kit, 150 PSI, ½" NPT, PTFE
57711	MFV Kit, 250 PSI, ½" NPT, PTFE
Retrofit Kit Numbers	Description
57706	MFV Retrofit Kit, 150 PSI
57707	MFV Retrofit Kit, 250 PSI



Pro Version

Designed for Sodium Hypochlorite Applications

Body Material: PVC

MFV Kit Numbers	Description
58062	MFV Kit, 150 PSI, ½" NPT, Polyprel
58064	MFV Kit, 250 PSI, ½" NPT, Polyprel
Retrofit Kit Numbers	Description
58060	MFV Pro Retrofit Kit, 150 PSI
58061	MFV Pro Retrofit Kit, 250 PSI

Mode of Operation

Priming

- Connect all tubing per instructions.
- Turn black knob about 1/8 turn CCW to stop point to open bypass port.
- Set pump at 100% speed and 100% stroke length. Start pump. Air will be evacuated from the liquid end and once fluid has been flowing through the bypass port tubing for 10-20 seconds, the pump is primed.
- Stop pump and return black knob to normal position.

NOTE:

The pumps are normally self-priming if suction lift is less than 5 feet (1.5 meters), check valves are wet (there is usually water in the pump head when shipped from the factory), and the steps above are followed. If the pump does not self-prime, you can choose one of the 2 ways to help prime:

- Remove the MFV and discharge cartridges and slowly pour water or solution into the pump head until it is filled. Replace cartridges and MFV valve and repeat steps above.
- Or, temporarily improve suction conditions by pumping from a container closer to or above pump.

Depressurizing the Discharge Line

When preparing to maintain the pump or any component in the discharge line, the multifunction valve is used to depressurize the line. Be sure an injection check valve is properly installed and is operating, and that all tubing connections on the MFV are secure.

- Turn off the pump.
- If any valves have been installed downstream of the pump, close them.
- If the supply tank for the pump is higher than the pump head, fluid will flow through unless a suction line valve is closed.
- Turn the black knob on the MFV about 1/8 turn CCW to its open position. This relieves pressure between the pump and the MFV.
- To release line pressure, while the black knob is in open position, turn the yellow knob and hold open until fluid flow through the bypass port stops.

Multifunction Valve Kits Instructions

For Liquid end Series 900, 800, 400 and 300- Code NI

Follow the instructions below to install the new multifunction valve. Before you begin, ensure:

1. Pump is turned OFF.
2. Pump discharge line is depressurized.
3. Pump discharge tubing is removed.

Your MFV kit includes:

- New Multifunction Valve (MFV)
- 3/8" Tubing for Relief Line
- (3) Black Polyprel® O-rings **OR** (3) White PTFE O-rings (depending on the kit)
- Quick Start Guide

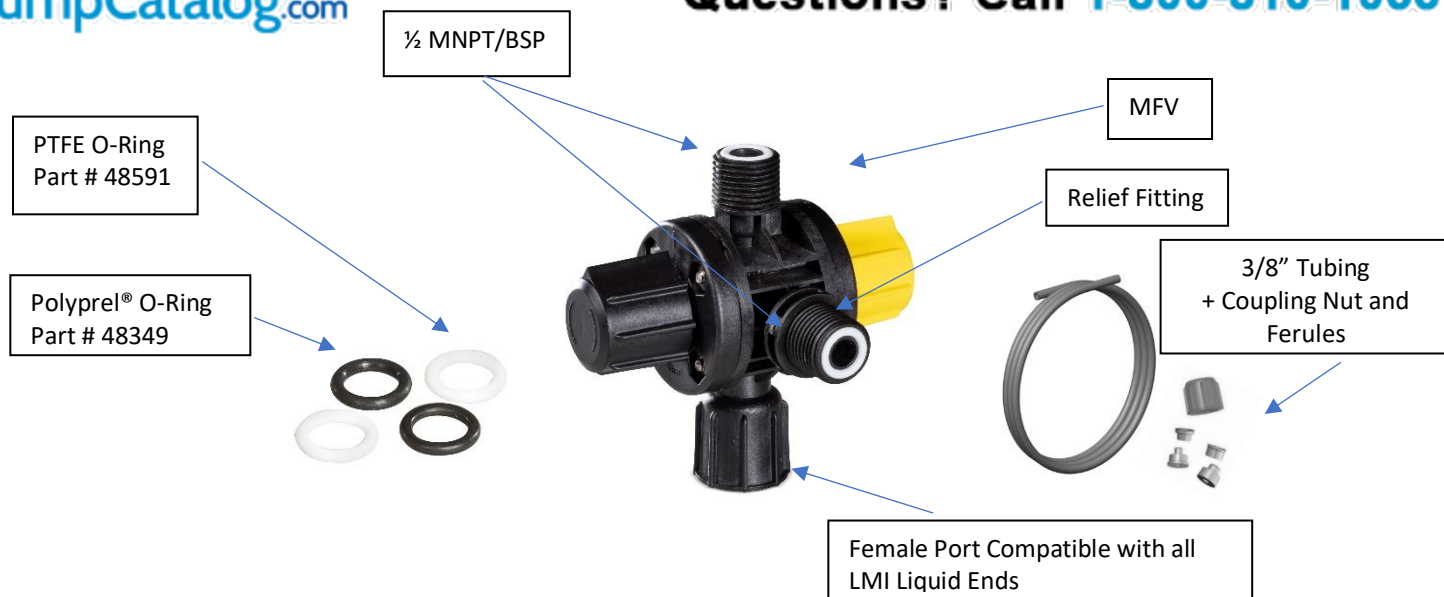

- Place the O-ring on the straight discharge fitting of the pump.
- Mount the new MFV to the liquid end of the pump.
- Tighten the coupling nut on the MFV. Do not over tighten.
- Place the o-ring on the MFV fitting. NOTE: Orient the MFV in the desired position prior to fully tightening.
- Reattach the tubing to the new MFV.
- Place the O-ring on the relief fitting.
- Attach the 3/8" tubing only to the relief line.
- NOTE: The relief line must be mechanically fastened to the supply tank.

Retrofit Kits Instructions

Follow the instructions below to upgrade the 4-function and 3-function valves to the new multifunction valve design using the retrofit kit. Before you begin, ensure:

1. Pump is turned OFF.
2. Pump discharge line is depressurized.
3. Tubings are removed.

Tools you will need:

1. 13/16" or 20mm socket wrench.
2. Screw driver or pin to remove the cartridge.

Your Retrofit kit includes:

- New Multifunction Valve (MFV)
- (3) Black Polyprel® O-rings
- (3) White PTFE O-rings
- (1) 3/8" Tubing for Relief Line
- (2) Fittings for Liquid End's:
 - PVDF double ball fitting for Series 900 and 800
 - PVDF single ball fitting for Series 700, 400, and 300
- Quick Start Guide



For Liquid end Series 900 and 800:

- Remove the existing multifunction valve on the pump.
- Use a screwdriver or pin to gently remove the cartridge.
- Place the cartridge inside the double ball fitting. NOTE: Ensure the cartridge is installed correctly on the same direction as the flow and o-ring installed.
- Tighten the fitting to the discharge port of the pump. 50 inch-pounds is recommended. Do not over tighten.
- NOTE: Select the o-ring (Polyprel® or PTFE) based on chemical compatibility or consistent with what is installed on the pump.
- Place the compatible o-ring into the o-ring groove of the discharge fitting, ensure the o-ring is fully seated into the groove. NOTE: Orient the MFV in the desired position prior to fully tightening.
- Attach the new multifunction valve.
- Remove the yellow cap from MFV and ensure compatible o-ring is installed on the discharge of the MFV.
- Reattach the tubings on the new MFV.
- Place the O-ring on the relief fitting.
- Attach the 3/8" tubing only to the relief line.
- NOTE: The relief line must be mechanically fastened to the supply tank.

For Liquid end Series 700, 400 and 300:

- Follow the same instructions above using the single ball fitting.

About Ingersoll Rand

Ingersoll Rand (NYSE:IR), driven by an entrepreneurial spirit and ownership mindset, is committed to helping make life better. We provide innovative and mission-critical industrial, energy, medical and specialty vehicle products and services across 40+ respected brands designed to excel in even the most complex and harsh conditions where downtime is especially costly. Our employees connect to customers for life by delivering proven expertise, productivity and efficiency improvements. For more information, visit www.IRCO.com.



LMI* is a registered trademark of Milton Roy, LLC.
LIQUIFRAM™ is a trademark of Milton Roy, LLC.
AUTOPRIME™ is a trademark of Milton Roy, LLC.
PRO PAC™ is a trademark of Milton Roy, LLC.
FASTPRIME™ is a trademark of Milton Roy, LLC.
ROYTRONIC® is a registered trademark of Milton Roy, LLC.
MICROPACE™ is a trademark of Milton Roy, LLC.
© 2001, 2018 Milton Roy, LLC.
info@lmipumps.com
www.lmipumps.com

