

Condensate MicroVision

The MicroVision Condensate Controller delivers condensate return monitoring with a reliable and accurate temperature compensated conductivity probe. Worry less about installation with 'plug and play' simplicity with user friendly easy to use programming to save time and money on equipment installation. This latest addition to the MicroVision family of controllers is configured specifically for precise measurement of conductivity in the condensate return and allows for more efficient use of time in inhibiting corrosion.



FEATURES

- Graphical display
- Activates diverter valve
- Five digital inputs
- Selectable sampling modes
- 5 output relays with selectable timers
- Scalable 4-20mA output to report condensate conductivity
- Hall-effect and pulse water meter inputs
- Digital drum levels
- Boiler interlock input

OPERATING BENEFITS

- Simple Programming
- Easy Installation and Easy to Use
- Reliable Conductivity Probe
- Heavy Duty Enclosure

Input and Output Functionality

System Outputs	Blowdown	Timer 1	Timer 2	Timer 3	Alarm/Timer 4
Output Type	Relay 1	Relay 2	Relay 3	Relay 4	Dry Contact
Limit		X	X	X	X
28 Day		X	X	X	X
Pulse		X	X	X	X
Percent		X	X	X	X
Cycle		X	X	X	X
System Alarm					X
Programmable Inputs	Input 1	Input 2	Input 3	Input 4	Input 5
Drum Level		X	X	X	X
Dry Contact Water Meter	X	X	X	X	X
Hall Effect	X				
Interlock					X

SPECIFICATION AND MODEL SELECTION

MODEL	Power Wiring
MVBXCHXC025-XXX	Conduit connections
MVBXCHXC025-CZXXX	Conduit connections; 230V
MVBXPHXC025-XXX	Prewired with pigtails

ENGINEERING DATA

Controller	
Enclosure	NEMA 4X / IP65
Power Supply	100-240VAC +/-10% / 50/60Hz / 5A
Control Output	5 Amp Max – Prewired Relay 1 Amp Per Relay – Dry Contact
Display	LCD
Sensor	
Sensor Type	Condensate Electrode
Cable Length	25 Feet Max. (Use of the supplied cable is required)
Maximum Temperature	392°F / 200°C
Maximum Pressure	250 PSI (17 BAR)
Saturated Steam Max.	210 PSI (14.4 Bar)
Conductivity Range	0 to 20 µS/cm
Cell Constant and TC	K=0.1 – 1000 RTD
Materials of Construction	316 SS and PEEK

PARTS AND ACCESSORIES

Part Number	Description
CCBS-C-25	Condensate Probe Assembly w/ 25 ft Cable
13-511-07-1	25 feet cable - Must be used with MicroVision Condensate Controller
03-135-02	Tee, Iron Black, 0.75" NPT

DIMENSIONS

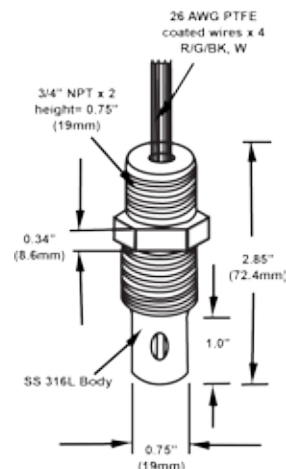
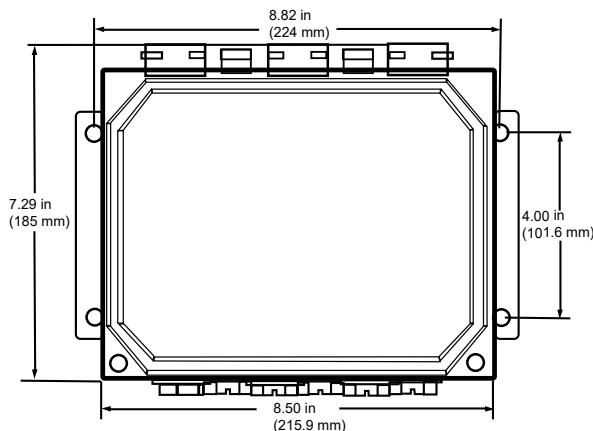

 27101 Airport Road
 Punta Gorda, FL 33982

An ISO Certified Company

 ORDER ONLINE www.PumpCatalog.com

 MVC001 H17