

WILDEN[®]
Part of Pump Solutions Group
A **DOVER** COMPANY

EOM
Engineering
Operation &
Maintenance

XSD HS
Saniflo™ Hygienic Series
Surge Dampener



Where Innovation Flows

www.wildenpump.com



TABLE OF CONTENTS

SECTION 1 CAUTIONS—READ FIRST! 1

SECTION 2 WILDEN PUMP DESIGNATION SYSTEM 2

SECTION 3 HOW IT WORKS—PUMP & AIR DISTRIBUTION SYSTEM...... 3

SECTION 4 DIMENSIONAL DRAWINGS..... 4

SECTION 5 PERFORMANCE

 XSD1-1/2 HS 5

 XSD2 HS 6

 XSD3 HS 7

SECTION 6 SUGGESTED INSTALLATION & TROUBLESHOOTING 9

SECTION 7 DISASSEMBLY / REASSEMBLY 11

 Reassembly Hints & Tips. 14

 Cleaning-CIP 15

SECTION 8 EXPLODED VIEW & PARTS LISTING

 XSD1-1/2 HS 16















 XSD2 HS 18

 XSD3 HS 20

SECTION 9 ELASTOMER OPTIONS 22



CAUTIONS—READ FIRST!

-  **CAUTION:** Do not over-lubricate air supply — excess lubrication will reduce performance.
-  **CAUTION:** Do not exceed 8.6 bar (125 psig) air supply pressure.
-  **CAUTION:** When choosing dampener materials, be sure to check the temperature limits for all wetted components. Example: Viton® has a maximum limit of 177°C (350°F) but polypropylene has a maximum limit of only 79°C (175°F).
-  **CAUTION:** Maximum temperature limits are based upon mechanical stress only. Certain chemicals will significantly reduce maximum safe operating temperatures. Consult Chemical Resistance Guide (E4) for chemical compatibility and temperature limits.
-  **TEMPERATURE LIMITS:**
- | | | |
|---|----------------|----------------|
| Polypropylene | 0°C to 79°C | 32°F to 175°F |
| PVDF | -12°C to 107°C | 10°F to 225°F |
| PFA | 7°C to 107°C | 20°F to 225°F |
| Neoprene | -18°C to 93°C | 0°F to 200°F |
| Buna-N | -12°C to 82°C | 10°F to 180°F |
| EPDM | -51°C to 138°C | -60°F to 280°F |
| Viton® FKM | -40°C to 177°C | -40°F to 350°F |
| Wil-Flex™ | -40°C to 107°C | -40°F to 225°F |
| Saniflex™ | -29°C to 104°C | -20°F to 220°F |
| Polyurethane | -12°C to 66°C | 10°F to 150°F |
| Polytetrafluoroethylene (PTFE) ¹ | 4°C to 104°C | 40°F to 220°F |
| Nylon | -18°C to 93°C | 0°F to 200°F |
| Acetal | -29°C to 82°C | -20°F to 180°F |
| SIPD PTFE with Neoprene-backed | 4°C to 104°C | 40°F to 220°F |
| SIPD PTFE with EPDM-backed | -10°C to 137°C | 14°F to 280°F |
| Polyethylene | 0°C to 70°C | 32°F to 158°F |
| Geolast® | -40°C to 82°C | -40°F to 180°F |
- ¹4°C to 149°C (40°F to 300°F) - 13 mm (1/2") and 25 mm (1") models only.
- NOTE:** Not all materials are available for all models. Refer to Section 2 for material options for your dampener.
-  **WARNING:** Prevent static sparking. If static sparking occurs, fire or explosion could result. Dampener, pump, valves and containers must be grounded to a proper grounding point when handling flammable fluids and whenever discharge of static electricity is a hazard.
-  **CAUTION:** The process fluid and cleaning fluids must be chemically compatible with all wetted dampener components. Consult Chemical Resistance Guide (E4).
-  **CAUTION:** Dampener(s) should be thoroughly flushed before installing into process lines. FDA- and USDA-approved dampeners should be cleaned and/or sanitized before being used.
-  **CAUTION:** Always wear safety glasses when operating dampener. If diaphragm rupture occurs, process fluid may be forced out air exhaust.
-  **CAUTION:** Before any maintenance or repair is attempted, the compressed air line to the dampener and pump should be disconnected and all air pressure allowed to bleed from the system. Disconnect all intake, discharge and air lines. Drain the dampener by allowing any fluid to flow into a suitable container.
-  **CAUTION:** Blow out air line for 10 to 20 seconds before attaching to dampener to make sure all pipeline debris is clear. Use an in-line air filter. A 5µ (micron) air filter is recommended.
-  **CAUTION:** Dampeners cannot be used in submersible applications.
-  **CAUTION:** Tighten all hardware prior to installation.
-  **CAUTION:** ATEX products have been assessed for use in potentially explosive atmospheres in accordance with the European Directive 94/9/EC (ATEX 95). Users of ATEX products must be familiar with ATEX requirements and follow all safety guidelines. (Refer to Wilden Safety Supplement WIL-18510-E.)



WILDEN DESIGNATION SYSTEM

**XSD
HYGIENIC SERIES
EQUALIZER®**

LEGEND

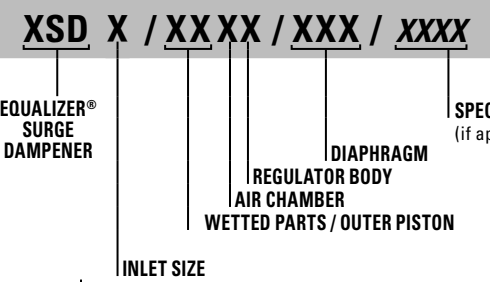

MATERIAL CODES

MODEL

XSD = ATEX EQUALIZER® SURGE DAMPENER

INLET SIZE

1-1/2 = 38 mm (1-1/2")
2 = 51 mm (2")
3 = 76 mm (3")

WETTED PATH / OUTER PISTON

SS = STAINLESS STEEL/
STAINLESS STEEL
SZ = STAINLESS STEEL/
NO PISTON

AIR CHAMBER

N = NICKEL-PLATED
ALUMINUM
S = STAINLESS STEEL

REGULATOR BODY

N = NICKEL-PLATED
ALUMINUM
S = STAINLESS STEEL

DIAPHRAGM

BNU = ULTRA-FLEX™ BUNA¹
EPU = ULTRA-FLEX™ EPDM¹
FBS = SANITARY BUNA¹
(Two Yellow Dots)
FES = SANITARY EPDM¹
FSS = SANIFLEX™¹
FWL = FULL STROKE SANITARY
WIL-FLEX™ IPD^{1,2,3}
FWS = SANITARY WIL-FLEX™¹
LEL = PTFE-EPDM BACKED
LAMINATE IPD^{1,2,3}
TEU = PTFE W/EPDM
BACKUP^{1,2}
TSU = PTFE W/SANIFLEX™
BACK-UP^{1,2}

NOTE:

¹Meets requirements of FDA CFR21.177

²Meets of USP Class VI

³Required for EHEDG certification

SPECIALTY CODES

0770 SaniFlo® HS

NOTE: MOST ELASTOMERIC MATERIALS USE COLORED DOTS FOR IDENTIFICATION.

Viton® is a registered trademark of DuPont Elastomers.
Santoprene® is a registered trademark of Exxon Mobil Corporation.

HOW IT WORKS — DAMPENER

All reciprocating pumps experience a pressure fluctuation. The Equalizer® minimizes unwanted pressure fluctuation by providing a supplementary pumping action. This is accomplished by using a diaphragm as a separation membrane within the Equalizer® to trap a given volume of liquid on one side and pressurized air on the other. When the fluid pressure falls in the system, the Equalizer® supplies additional pressure to the discharge line between pump strokes by displacing fluid via diaphragm movement. This movement provides the supplementary pumping action needed to virtually eliminate pressure variation and pulsation.

The Equalizer® automatically sets and maintains the correct air pressure matching the variations in liquid flow or discharge pressure generated by the pump. A shaft attached to the Equalizer® diaphragm triggers the addition or deletion of the air within the non-wetted side of the Equalizer®. The Equalizer® automatically adjusts to any pressure and/or flow setting of the pump with no need for manual adjustment of the unit and/or system. The Equalizer® has proven to be the cost effective choice for protecting your liquid process system from unwanted pulsation or pressure fluctuation. Contact your local Wilden distributor for further information on the Equalizer® and other pumping solutions.

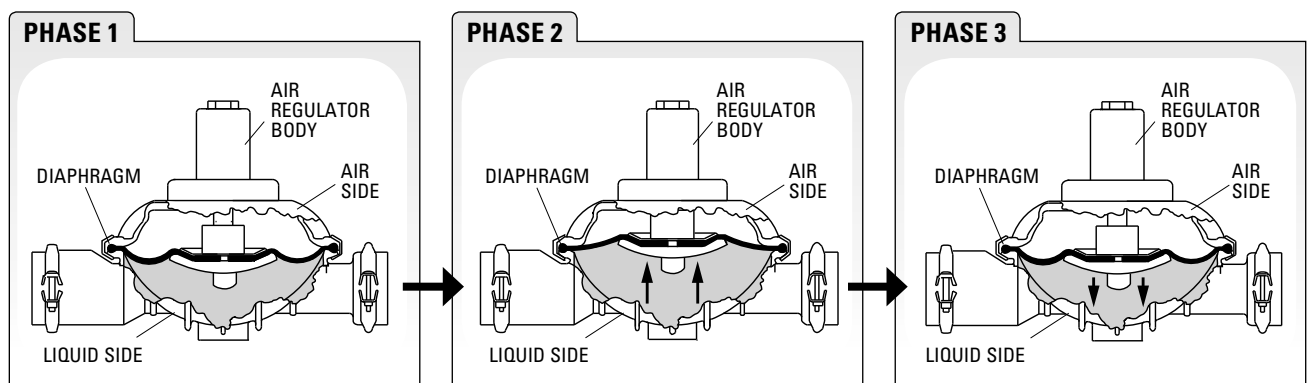

A compressed air line attached to the air regulator body sets and maintains pressure on the air side of the diaphragm. As the reciprocating pump begins its stroke, liquid discharge pressure increases which flexes the Equalizer® diaphragm inward. This action accumulates fluid in the liquid chamber (see Phase 2).

When the pump redirects its motion upon stroke completion, the liquid discharge pressure decreases and compressed air in the air side forces the Equalizer® diaphragm to flex outward displacing the fluid into the discharge line (see Phase 3). This motion provides the supplementary pumping action needed to minimize pressure fluctuation.

CAUTION: DO NOT EXCEED 8.6 BAR (125 PSIG) AIR PRESSURE.

Maximum temperature limits are based upon mechanical stress only. Certain chemicals will significantly reduce maximum safe operating temperatures. Consult Wilden Chemical Guide for chemical compatibility and temperature limits. Plastic Equalizers are manufactured with virgin plastic and are not UV-stabilized. Direct sunlight for prolonged periods can cause deterioration of these plastics. In this situation a metal Equalizer® is suggested.

Wear safety glasses. When diaphragm rupture occurs, material being pumped may be forced out air exhaust.

WARNING Prevent static sparking. If static sparking occurs, fire or explosion could result. Pump, Equalizer®, valves and containers must be grounded when handling flammable fluids and whenever discharge of static electricity is a hazard.

XSD1-1/2 Saniflo™ HS

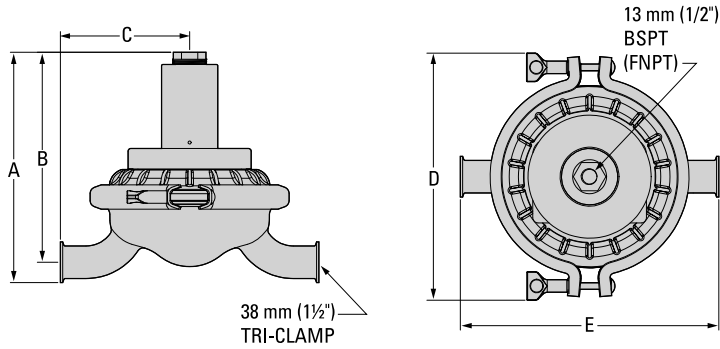

DIMENSIONS

ITEM	METRIC (mm)	STANDARD (inch)
A	284	11.2
B	259	10.2
C	160	6.3
D	305	12.0
E	320	12.6

XSD2 Saniflo™ HS

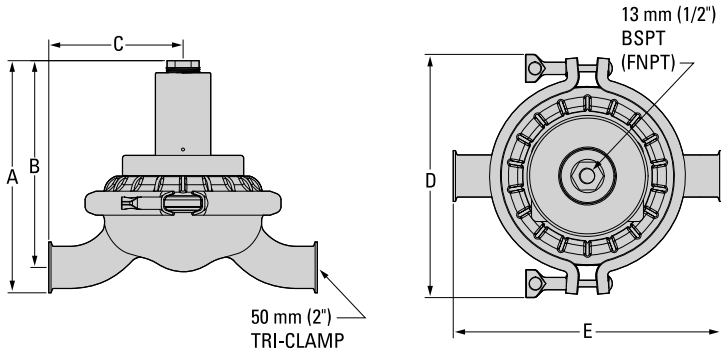

DIMENSIONS

ITEM	METRIC (mm)	STANDARD (inch)
A	292	11.5
B	259	10.2
C	170	6.7
D	305	12.0
E	338	13.3

XSD3 Saniflo™ HS

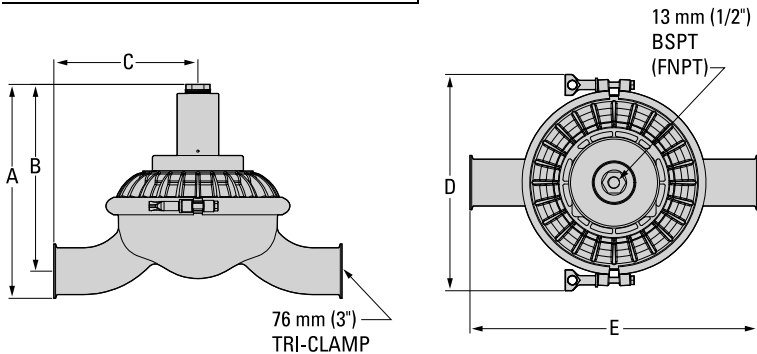

DIMENSIONS

ITEM	METRIC (mm)	STANDARD (inch)
A	358	14.1
B	312	12.3
C	241	9.5
D	363	14.3
E	482	19.0

XSD1½ HS PERFORMANCE

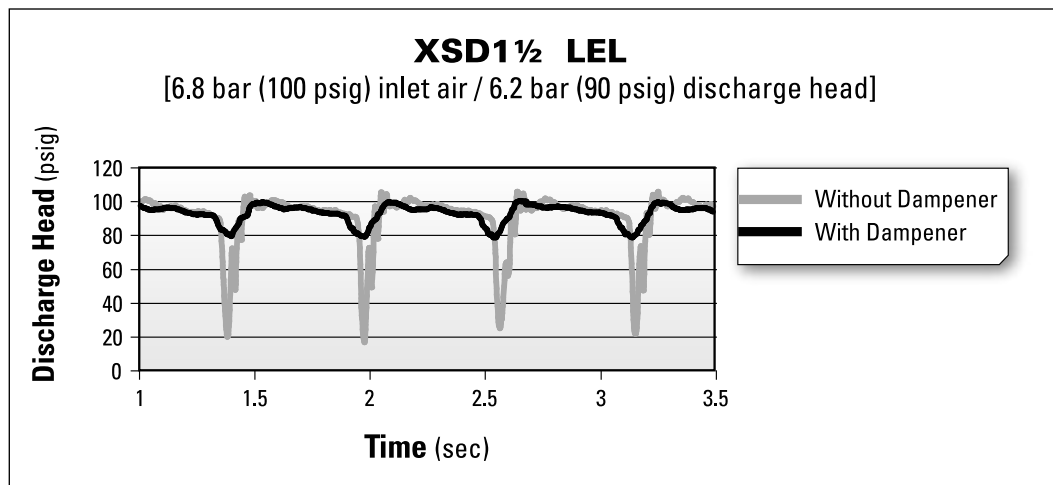
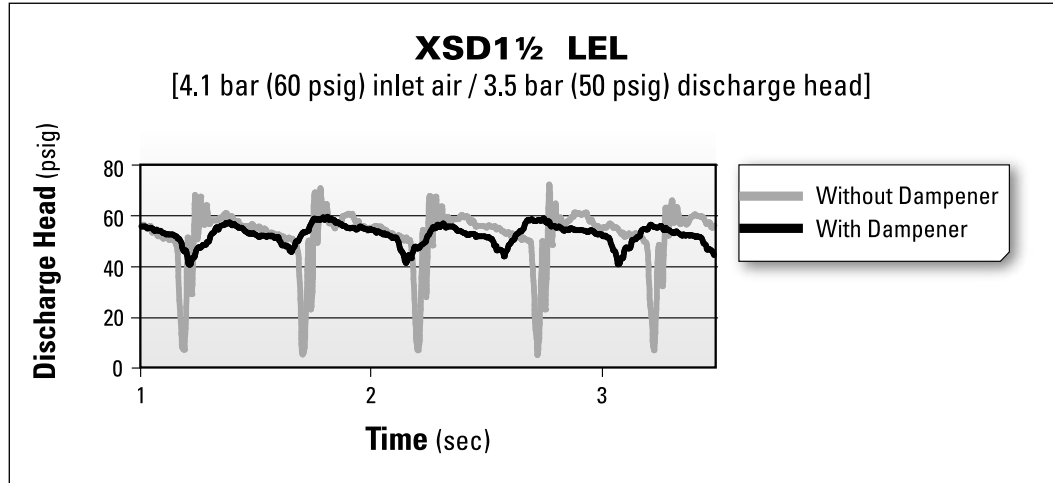

These charts show discharge head fluctuations for a diaphragm pump with and without a dampener. By reviewing the variation in pressure, the level of dampening can be estimated for an application. For example, the head pressure generated by a 38 mm (1-1/2") pump operating at 6.8 bar (100 psig) air inlet pressure and 6.2 bar (90 psig) head pressure varies between 0.8 bar (12 psig) and 7.4 bar (108 psig)

resulting in a total pressure fluctuation of 96 psig for each stroke. When an XSD1 1/2/SZSS/LEL/0770 dampener is installed in the application, the head pressure varies between 5.1 bar (74 psig) and 6.8 bar (99 psig) resulting of a pressure fluctuation of only 1.7 bar (25 psig). This results in a 74% reduction in head pressure fluctuation.

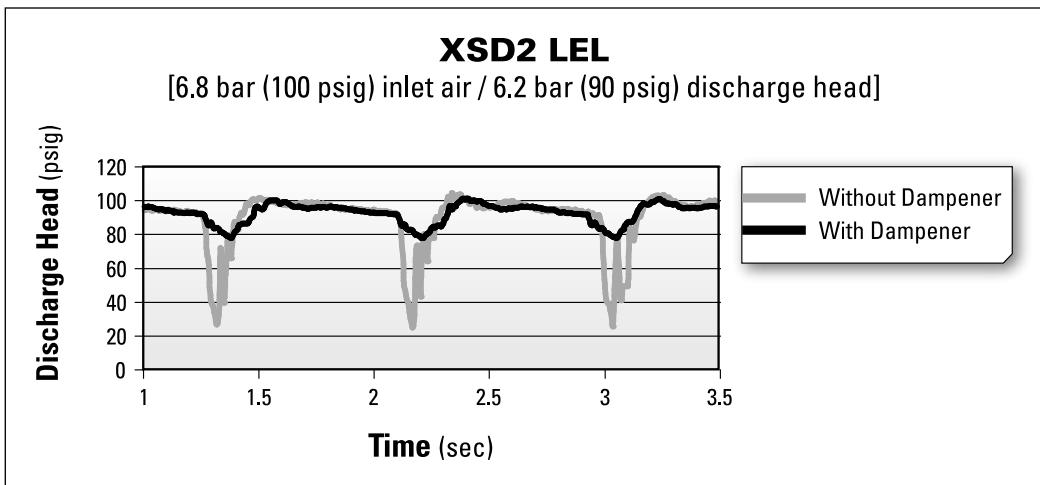
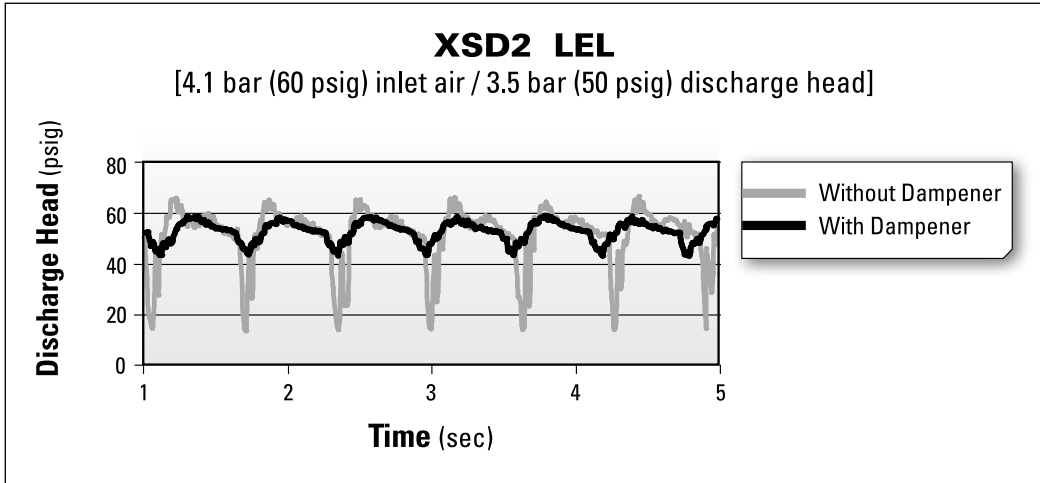

These charts show discharge head fluctuations for a diaphragm pump with and without a dampener. By reviewing the variation in pressure, the level of dampening can be estimated for an application. For example, the head pressure generated by a 51 mm (2") pump operating at 6.8 bar (100 psig) air inlet pressure and 6.2 bar (90 psig) head pressure varies between 1.4 bar (20 psig) and 7 bar (102 psig)

resulting in a total pressure fluctuation of 5.7 bar (82 psig) for each stroke. When an XSD2/SZSS/LEL/0770 dampener is installed in the application, the head pressure varies between 5.2 bar (75 psig) and 6.8 bar (100 psig) resulting of a pressure fluctuation of only 1.7 bar (25 psig). This results in a 70% reduction in head pressure fluctuation.

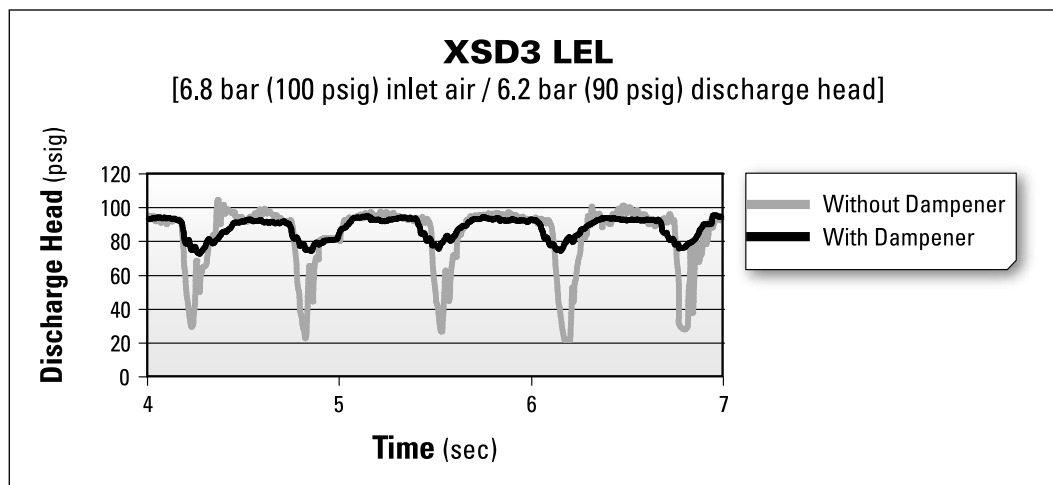
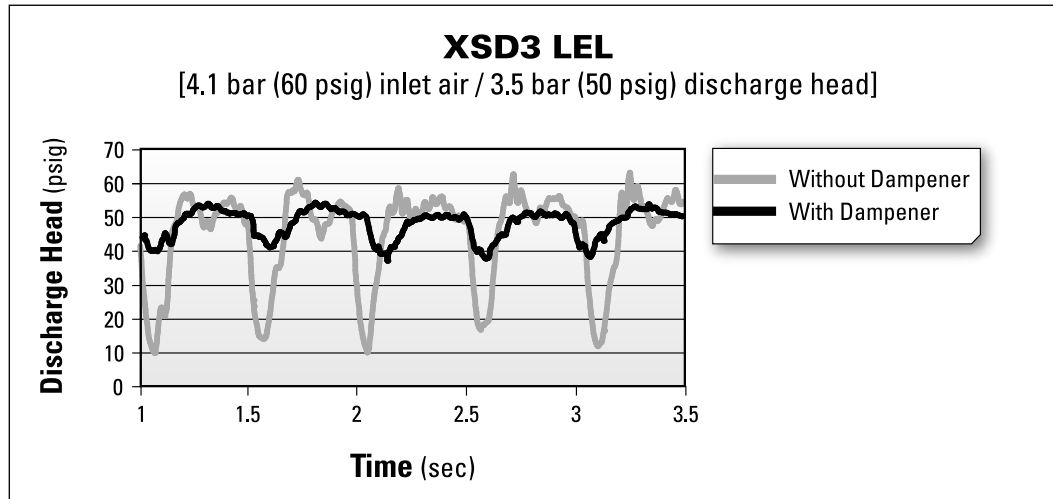

These charts show discharge head fluctuations for a diaphragm pump with and without a dampener. By reviewing the variation in pressure, the level of dampening can be estimated for an application. For example, the head pressure generated by a 76 mm (3") pump operating at 6.8 bar (100 psig) air inlet pressure and 6.2 bar (90 psig) head pressure varies between 1.4

bar (21 psig) and 7.1 bar (103 psig) resulting in a total pressure fluctuation of 82 psig for each stroke. When an XSD3/SZSS/LEL/0770 dampener is installed in the application, the head pressure varies between 4.9 bar (71 psig) and 6.5 bar (94 psig) resulting of a pressure fluctuation of only 1.6 bar (23 psig). This results in a 72% reduction in head pressure fluctuation.

NOTES

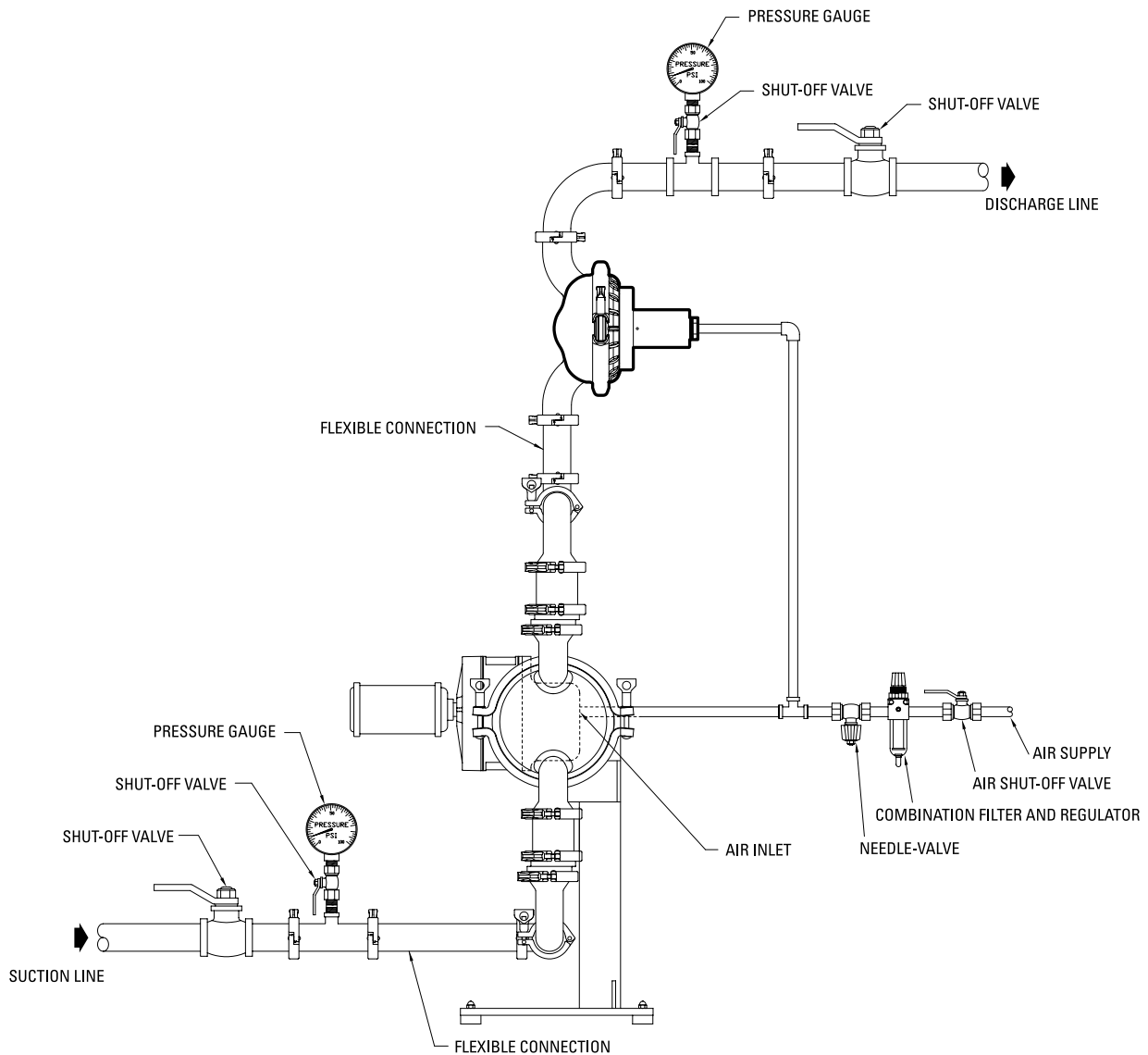

The model XSD1-1/2 Hygienic Series™ has a 38 mm (1-1/2") tri clamp style inlet/discharge. The model XSD2 has a 51 mm (2") inlet/discharge. The model XSD3 has a 76 mm (3") inlet/discharge. The Equalizer® can be installed in either direction. A variety of materials are available to satisfy temperature, chemical compatibility, abrasion and flex concerns. The Equalizer® installed on the discharge side of the pump minimizes pulsation and protects in-line equipment. It can also be connected on the suction side to prevent water hammer associated with a positive inlet condition. The model XSD1-1/2 Hygienic Series™ is engineered for use with Wilden 38 mm (1-1/2") PX4 Hygienic Series™ pumps. The model XSD2 Hygienic Series™ is engineered for use with Wilden 51 mm (2") PX8 Hygienic Series™ pumps. The model XSD3 is engineered for use with Wilden PX15 Hygienic Series™ pumps.

Install the Equalizer® as shown above. The use of flexible connections and a Filter, Regulator, Lubricator (FRL) will extend parts life on the. Shut-off valves on the suction side of pump and the discharge side of Equalizer® will enable maintenance personnel to safely service the equipment. To maximize effectiveness install the Equalizer® as close as possible to the discharge of the pump. **It is important to support the pipe immediately downstream from the Equalizer®.** Use a tee connector on the pump air supply line and connect the line to the Equalizer® regulator body. This tee connector should be installed after the FRL. The Equalizer® consumes very little air, therefore, a 1/4" hose is more than adequate to supply enough air volume. When the air supply to the pump is shut down, the air to the Equalizer® will be shut off as well.

- 1) When there is a significant drop in the fluid discharge pressure, there will be a noticeable release of air through the small bleed hole in the air regulator body. This is how the Equalizer® automatically adjusts itself for optimal suppression. This is a good way of verifying proper operation of the unit. If there is a continuous discharge of air out this hole during steady fluid discharge pressure, the Equalizer® is not functioning properly and should be inspected. The air regulator body houses three (3) Glyd rings.
- 2) Fluid leakage around the clamp band area is normally stopped by tightening the clamp band bolts. If leakage continues, unit should be disassembled and inspected.
- 3) Air leakage between the adapter plate and air chamber requires tightening of four air chamber bolts on the inside of the air chamber.

SURGE DAMPENER DISASSEMBLY

Tools Required:

- Deep well socket and ratchet (3/4")
- Dead blow mallet
- Hex (Allen®) wrenches (3/16" and 1/4")
- Large adjustable wrench or channel lock pliers

Tools Recommended:

- Large pipe wrench
- Vise equipped w/soft jaws (such as aluminum, plastic, plywood or other suitable material)

CAUTION: Before any maintenance or repair is attempted, the compressed air line to the Equalizer® and the pump should be disconnected and all air pressure allowed to bleed from the system. Disconnect all intake, discharge and air lines. Be aware of any hazardous effects of contact with your process fluid. PLEASE READ ALL DIRECTIONS BEFORE STARTING DISASSEMBLY.

NOTE: The model photographed for these instructions is a XSD1-1/2 Hygienic Series. Other Equalizer® models should be similar in design but may contain slightly different components and fastener sizes.

**Step 1**

Remove large clamp band.

**Step 2**

Set liquid chamber aside.

**Step 3**

Remove reducer bushing at top of regulator.



Step 4

Loosen shaft assembly by using a 3/4" socket on shaft bolt inside air regulator body. Turn counter clockwise. One of two scenarios will occur: the diaphragm will loosen from shaft, or the shaft bolt will loosen from shaft.



Step 5

In either case, this will allow the removal of the diaphragm, shaft stop, shaft, shaft stop washer and bolt.



Step 6

Inspect shaft for nicks or abrasion. Small nicks can usually be dressed out. If shaft is chemically attacked or nicks are hindering operation, shaft should be replaced.



Step 7

Disassembly of the air chamber from the regulator adaptor plate is needed only in the event of air leakage.



Step 8

In the event of an air leak, remove the air chamber and replace the gasket.



Step 9

Disassembly of the regulator body from the regulator adaptor plate is needed only in the event of air leakage.

**Step 10**

In the event of an air leak, remove the regulator adaptor plate and replace the O-ring.

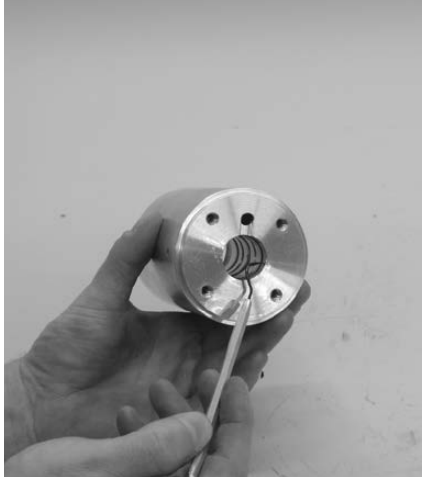
**Step 11**

Using an O-ring pick remove the Glyd-rings from air regulator body.

ASSEMBLY:

Upon performing applicable maintenance to the air distribution system, the Equalizer® can now be reassembled. Please refer to the disassembly instructions for photos and parts placement. To reassemble the Equalizer®, follow the disassembly instructions in reverse order. The air regulator body needs to be assembled first, then the diaphragms and finally the wetted path. Please find the applicable torque specifications on this page. The following tips will assist in the assembly process.

- Lubricate air regulator body, Glyd rings and shaft bore, center with NLGI grade 2 white EP bearing grease or equivalent.
- Clean the inside of the air regulator body bore to ensure no damage is done to new shaft seals.
- Stainless bolts should be lubed to reduce the possibility of seizing during tightening.

MAXIMUM TORQUE SPECIFICATIONS

Model	Description of Part	Torque
XSD1-½ HS	Air chamber/adapter plate	24.4 N·m (18 ft·lb)
	Air regulator body/adapter plate	7.9 N·m (70 in·lb)
	Outer piston/shaft bolt assembly (all diaphragms)	54.2 N·m (40 ft·lb)
XSD2 HS	Air chamber/adapter plate	24.4 N·m (18 ft·lb)
	Air regulator body/adapter plate	7.9 N·m (70 in·lb)
	Outer piston/shaft bolt assembly (rubber & PTFE)	109 N·m (80 ft·lb)
	Outer piston/shaft bolt assembly (Ultra-Flex™ & SIPD)	74.6 N·m (55 ft·lb)
XSD3 HS	Air chamber/adapter plate	24.4 N·m (18 ft·lb)
	Air regulator body/adapter plate	7.9 N·m (70 in·lb)
	Outer piston/shaft bolt assembly (rubber & PTFE)	109 N·m (80 ft·lb)
	Outer piston/shaft bolt assembly (Ultra-Flex™ & SIPD)	74.6 N·m (55 ft·lb)

SHAFT SEAL INSTALLATION:

PRE-INSTALLATION

- Once all of the old seals have been removed, the inside of the air regulator body should be cleaned to ensure no debris is left that may cause premature damage to the new seals.

INSTALLATION

The following tools can be used to aid in the installation of the new seals:

- Needle Nose Pliers
- Phillips Screwdriver
- Electrical Tape

- Wrap electrical tape around each leg of the needle nose pliers (heat shrink tubing may also be used). This is done to prevent damaging the inside surface of the new seal.
- With a new seal in hand, place the two legs of the needle nose pliers inside the seal ring. (See Figure A.)
- Open the pliers as wide as the seal diameter will allow, then with two fingers pull down on the top portion of the seal to form kidney bean shape. (See Figure B.)
- Lightly clamp the pliers together to hold the seal into the kidney shape. Be sure to pull the seal into as tight of a kidney shape as possible, this will allow the seal to travel down the bushing bore easier.
- With the seal clamped in the pliers, insert the seal into the bushing bore and position the bottom of the seal into the correct groove. Once the bottom of the seal is seated in the groove, release the clamp pressure on the pliers. This will allow the seal to partially snap back to its original shape.
- After the pliers are removed, you will notice a slight bump in the seal shape. Before the seal can be properly resized, the bump in the seal should be removed as much as possible. This can be done with either the Phillips screwdriver or your finger. With either the side of the screwdriver or your finger, apply light pressure to the peak of the bump. This pressure will cause the bump to be almost completely eliminated.
- Lubricate the edge of the shaft with NLGI grade 2 white EP bearing grease.
- Slowly insert the center shaft with a rotating motion. This will complete the resizing of the seal.
- Perform these steps for the remaining seal.

Figure A

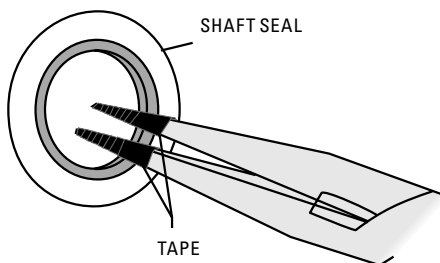
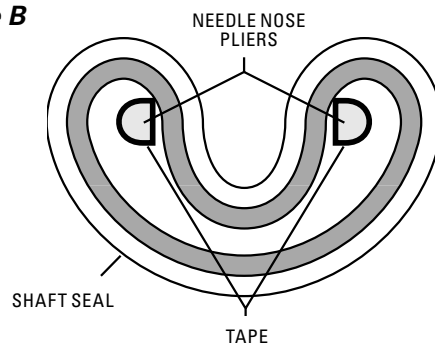

Figure B



The design of the pulsation dampener allows for ease of cleaning. This equipment can be disassembled for cleaning or cleaned in place without disassembly if the user has an appropriate CIP system. Before any cleaning is attempted, ensure that the cleaning fluids are compatible with all wetted components.

For best cleaning results consider the following information prior to cleaning of the dampener.

- For best Clean in Place (CIP) results, the pulsation dampener should be configured to the EHEDG configuration.
- Actual CIP effectiveness and processes should be validated on location by the end user's quality assurance personnel or meet internal guidelines. Post cleaning swab test is one method to accomplish this.
- The user should establish periodic inspections with full tear down to verify that the CIP processes continue to be effective as first validated.
- When CIP pressures are greater than 10 psig (0.7 bar), the dampener should be pre-loaded with air pressure to balance the CIP pressure in the pulsation dampener in order to maximize diaphragm life.

The following are some details to consider when cleaning the pulsation dampener.

- Through the EHEDG certification process, the dampener has been validated to clean equivalent to the inlet tubing of the same diameter. The cleaning chemical supplier should be consulted and advised of this for their chemical solution and application. The same guidelines for duration of cleaning cycle and temperature of cleaning fluid apply.

- Suggested flow rate for the 38 mm (1-1/2") dampener: 6.5 m³/hr (3 gpm); for the 51 mm (2") dampener: 11 m³/hr (50 gpm); for the 76 mm (3") dampener: 22 m³/hr (100 gpm) (usually higher is better).
- Typical CIP temperature is 77°C to 82°C (170°F to 180°F).
- Typical chemicals include NaOH (sodium hydroxide) caustic for wash and light acid and sanitizers for rinse.
- Once an initial CIP regimen is established, it may need to be modified to accommodate specific process and product differences or requirements. The most common adjustments include:
 - Changing cleaning time (extended or reduced pre-rinse, wash, rinses)
 - Changing cleaning flow rate
- The cleaning variables are related so that a pump user may be able to reduce the cleaning time by increasing the flow rate or chemical mix.
- Chlorinated sanitizers are known to cause premature failure of stainless steel and should be avoided.
- Activate the CIP system and in the process of cleaning other equipment in series, the dampener will be cleaned as well.

Draining the dampener.

- To assure that the dampener drains after cleaning, it should be mounted in a vertical position with respect to inlet/outlet ports.

EXPLODED VIEW & PARTS LISTING

XSD1-1/2 Saniflo™ HS

EXPLODED VIEW

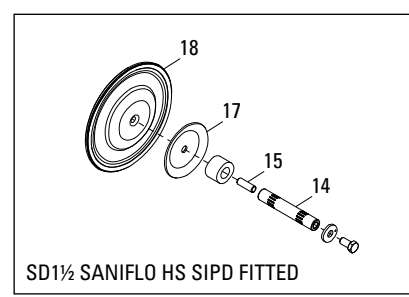
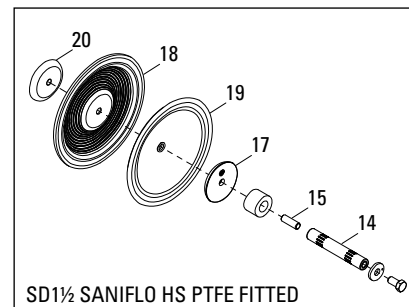
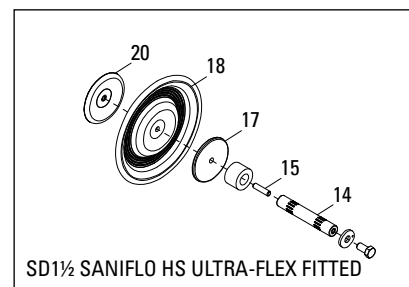
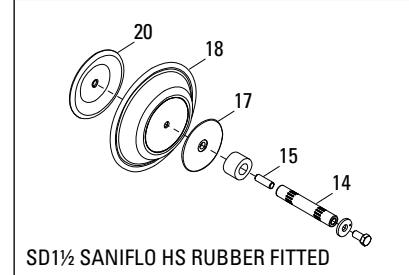
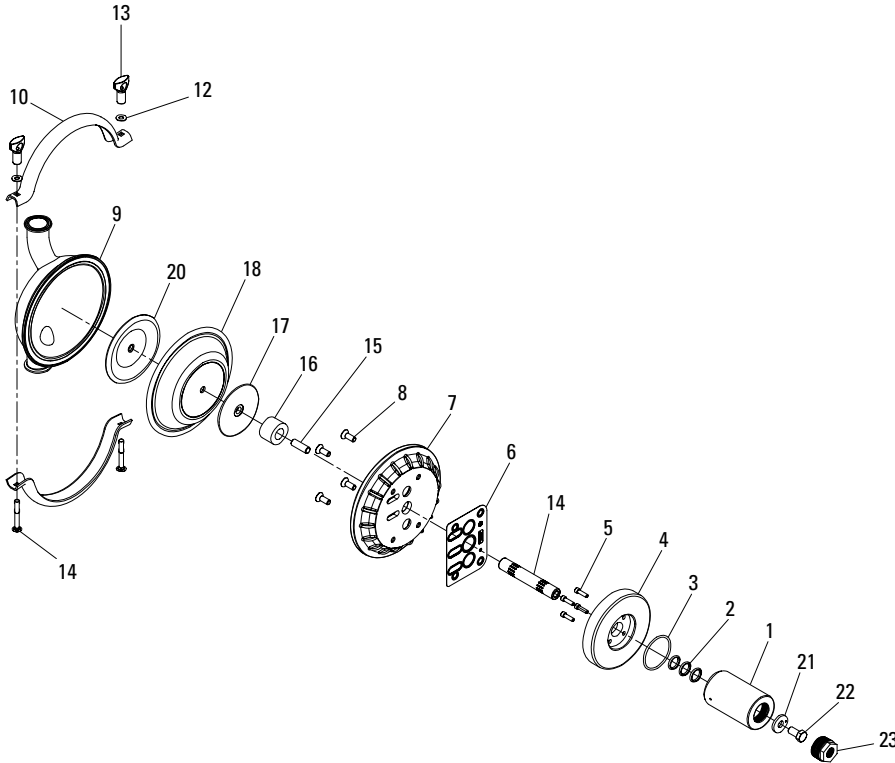

XSD1-1/2 Saniflo™ HS

PARTS LISTING

Item	Description	Qty.	XSD1½/SSNN/0770 P/N	XSD1½/SSSS/0770 P/N
1	Body, Regulator ¹	1	76-8515-06	76-8515-03
2	Ring II, Glyd	3	08-3210-55-225	08-3210-55-225
3	O-Ring -230 (Ø2.484 x Ø.139)	1	76-1285-52	76-1285-52
4	Plate, Regulator Adapter	1	76-8510-06	76-8510-03
5	Screw, 1/4-20 x .75 Soc Hd Cap	4	76-6250-03	76-6250-03
6	Gasket, Center Block	1	04-3529-52	04-3529-52
7	Chamber, Air	1	04-3660-06	04-3660-03
8	Screw, 3/8-16 x 1.00 Soc Flt Csk Hd Cap	4	71-6250-08	71-6250-08
9	Chamber, Liquid	1	76-5000-10-385P	76-5000-10-385P
10	Clamp Band, Half	2	04-7330-03	04-7330-03
11	Bolt, 5/16-18 x 2.50 Rnd Hd Sq Neck	2	04-6070-03	04-6070-03
12	Washer, Plain	2	01-6732-03	01-6732-03
13	Nut, 5/16-18 Hex	2	08-6661-10	08-6661-10
14	Shaft, Straight	1	76-3800-03	76-3800-03
	Shaft, Ultra-Flex™	1	04-3830-03-07	04-3830-03-07
15	Stud, 1/2-20 x 1.50 Threaded	1	04-6150-08	04-6150-08
	Stud, 3/8-16 x 1.50 Threaded, Ultra-flex™	1	04-6152-08	04-6152-08
16	Stop, Shaft	1	76-8800-17	76-8800-17
17	Piston, Rubber & TPE Inner	1	04-3700-01-700	04-3700-01-700
	Piston, Ultra-Flex™ Inner	1	04-3760-01-700	04-3760-01-700
	Piston, PTFE Inner	1	04-3752-01	04-3752-01
	Piston, SIPD Inner	1	04-3700-08	04-3700-08
18	Diaphragm, Primary	1	*	*
	Diaphragm, Ultra-Flex™	1	*	*
	Diaphragm, PTFE	1	*	*
	Diaphragm, SIPD	1	*	*
19	Diaphragm, Back-Up	1	*	*
20	Piston, Rubber & TPE Outer	1	04-4550-10-385P	04-4550-10-385P
	Piston, Ultra-Flex™ Outer	1	04-4560-10-385P	04-4560-10-385P
	Piston, PTFE Outer	1	04-4600-10-385P	04-4600-10-385P
21	Washer, Stop	1	70-6790-08	70-6790-08
22	Screw, 1/2-20 x 1.00 Hex Cap	1	04-6090-08	04-6090-08
23	Reducer Bushing	1	70-6950-08	71-6950-03

¹Air Regulator Body includes qty. 3 Glyd Rings.

*Elastomer options listed on page 22.

All Bold face items are primary wear items.

XSD2 Saniflo™ HS

EXPLODED VIEW

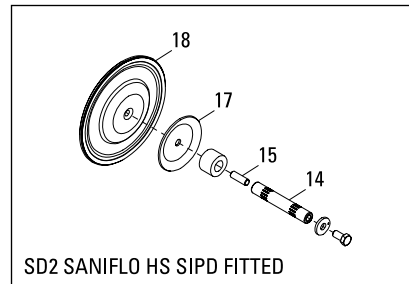
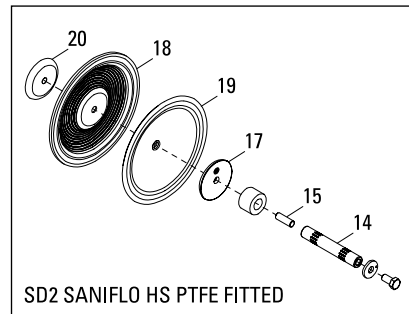
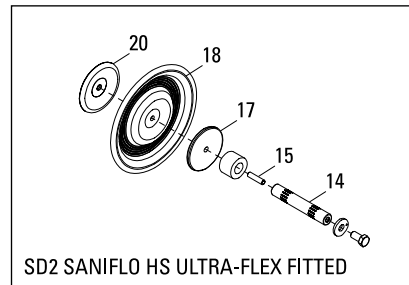
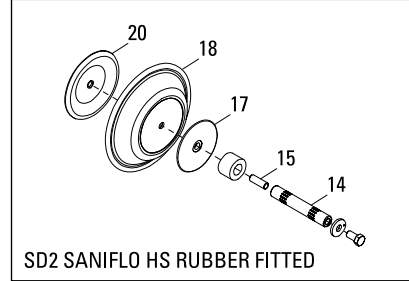
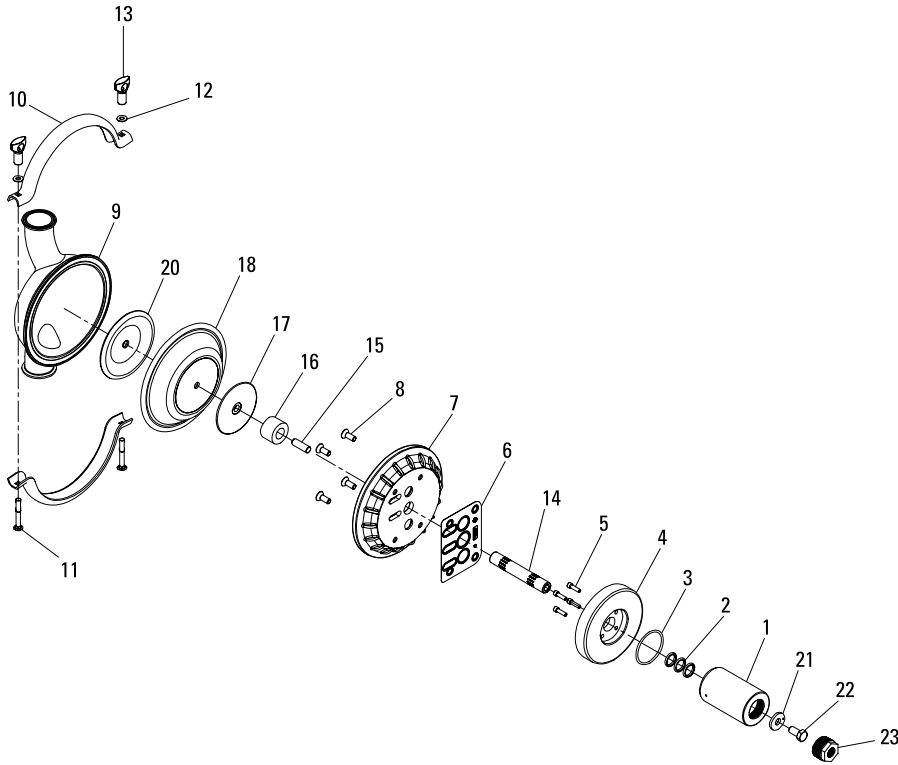

XSD2 Saniflo™ HS

PARTS LISTING

Item	Description	Qty.	XSD2/SSNN/0770 P/N	XSD2/SSSS/0770 P/N
1	Body, Regulator ¹	1	76-8515-06	76-8515-03
2	Ring II, Glyd	3	08-3210-55-225	08-3210-55-225
3	O-Ring -230 (Ø2.484 x Ø.139)	1	76-1285-52	76-1285-52
4	Plate, Regulator Adapter	1	76-8510-06	76-8510-03
5	Screw, 1/4-20 x .75 Soc Hd Cap	4	76-6250-03	76-6250-03
6	Gasket, Center Block	1	04-3529-52	04-3529-52
7	Chamber, Air	1	04-3660-06	04-3660-03
8	Screw, 3/8-16 x 1.00 Soc Flt Csk Hd Cap	4	71-6250-08	71-6250-08
9	Chamber, Liquid	1	77-5000-10-385P	77-5000-10-385P
10	Clamp Band, Half	2	04-7330-03	04-7330-03
11	Bolt, 5/16-18 x 2.50 Rnd Hd Sq Neck	2	04-6070-03	04-6070-03
12	Washer, Plain	2	01-6732-03	01-6732-03
13	Nut, 5/16-18 Hex	2	08-6661-10	08-6661-10
14	Shaft, Straight	1	76-3800-03	76-3800-03
	Shaft, Ultra-Flex™	1	04-3830-03-07	04-3830-03-07
15	Stud, 1/2-20 x 1.50 Threaded	1	04-6150-08	04-6150-08
	Stud, 3/8-16 x 1.50 Threaded, Ultra-Flex™	1	04-6152-08	04-6152-08
16	Stop, Shaft	1	76-8800-17	76-8800-17
17	Piston, Rubber & TPE Inner	1	04-3700-01-700	04-3700-01-700
	Piston, Ultra-Flex™ Inner	1	04-3760-01-700	04-3760-01-700
	Piston, PTFE Inner	1	04-3752-01	04-3752-01
	Piston, SIPD Inner	1	04-3700-08	04-3700-08
18	Diaphragm, Primary	1	*	*
	Diaphragm, Ultra-Flex™	1	*	*
	Diaphragm, PTFE	1	*	*
	Diaphragm, SIPD	1	*	*
19	Diaphragm, Back-Up	1	*	*
20	Piston, Rubber & TPE Outer	1	04-4550-10-385P	04-4550-10-385P
	Piston, Ultra-Flex™ Outer	1	04-4560-10-385P	04-4560-10-385P
	Piston, PTFE Outer	1	04-4600-10-385P	04-4600-10-385P
21	Washer, Stop	1	70-6790-08	70-6790-08
22	Screw, 1/2-20 x 1.00 Hex Cap	1	04-6090-08	04-6090-08
23	Reducer Bushing	1	70-6950-08	71-6950-03

¹Air Regulator Body includes qty. 3 Glyd Rings.

*Elastomer options listed on page 22.

All Bold face items are primary wear items.

XSD3 Saniflo™ HS

EXPLODED VIEW

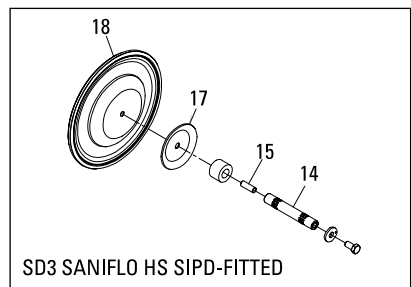
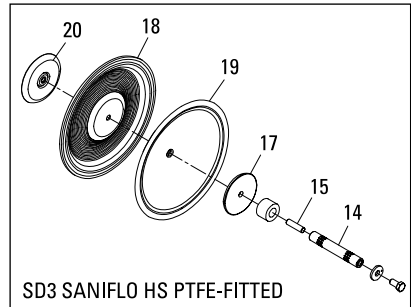
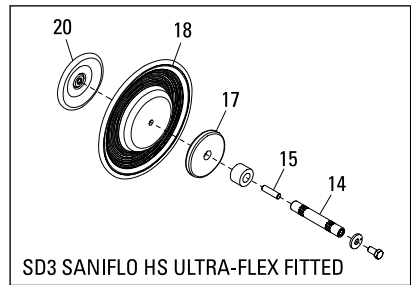
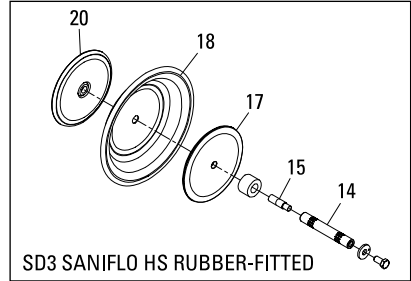
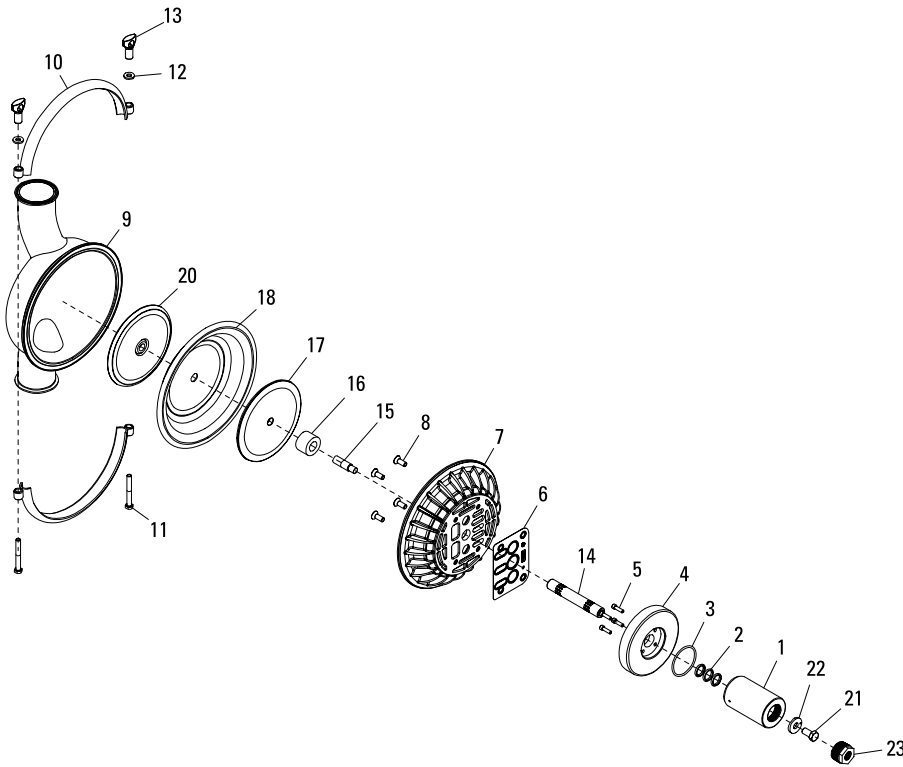

XSD3 Saniflo™ HS

PARTS LISTING

Item	Description	Qty	XSD3/SSNN/0770 P/N	XSD3/SSSS/0770 P/N
1	Body, Regulator ¹	1	76-8515-06	76-8515-03
2	Ring II, Glyd	3	08-3210-55-225	08-3210-55-225
3	O-Ring -230 (Ø2.484 x Ø.139)	1	76-1285-52	76-1285-52
4	Plate, Regulator Adapter	1	76-8510-06	76-8510-03
5	Screw, 1/4-20 x .75 Soc Hd Cap	4	76-6250-03	76-6250-03
6	Gasket, Center Block	1	04-3529-52	04-3529-52
7	Chamber, Air	1	08-3660-06	08-3660-06
8	Screw, 3/8-16 x 1.00 Soc Flt Csk Hd Cap	4	71-6250-08	71-6250-08
9	Chamber, Liquid	1	78-5000-10-385P	78-5000-10-385P
10	Clamp Band, Half	2	08-7300-03	08-7300-03
11	Screw, 3/8-16 x 3.00 Hex Hd Cap	2	08-6120-03	08-6120-03
12	Washer, Plain	2	04-6741-03	04-6741-03
13	Nut, Wing	2	08-6671-10	08-6671-10
14	Shaft, Straight	1	77-3800-03	77-3800-03
15	Shaft, Stud Adapter, Rubber & TPE	1	71-6153-08	71-6153-08
	Stud, 1/2-20 x 1.88 Threaded, Ultra-flex™	1	08-6150-08	08-6150-08
	Stud, 1/2-20 x 1.50 Threaded, SIPD	1	04-6150-08	04-6150-08
16	Stop, Shaft	1	76-8800-17	76-8800-17
17	Piston, Rubber & TPE Inner	1	08-3700-01	08-3700-01
	Piston, Ultra-Flex™ Inner	1	08-3761-01	08-3761-01
	Piston, PTFE Inner	1	08-3750-01	08-3750-01
	Piston, SIPD Inner	1	04-3700-08	04-3700-08
18	Diaphragm, Primary	1	*	*
	Diaphragm, Ultra-Flex™	1	*	*
	Diaphragm, PTFE	1	*	*
	Diaphragm, SIPD	1	*	*
19	Diaphragm, Back-Up	1	*	*
20	Piston, Rubber & TPE Outer	1	08-4550-10-385P	08-4550-10-385P
	Piston, Ultra-Flex™ Outer	1	08-4560-10-385P	08-4560-10-385P
	Piston, PTFE Outer	1	08-4600-10-385P	08-4600-10-385P
21	Screw, 1/2-20 x 1.00 Hex Cap	1	04-6090-08	04-6090-08
22	Washer, Stop	1	70-6790-08	70-6790-08
23	Reducer Bushing	1	70-6950-08	71-6950-03

¹Air Regulator Body includes qty. 3 Glyd Rings.

*Elastomer options listed on page 22.

All Bold face items are primary wear items.

ELASTOMER OPTIONS

	ELASTOMER	DIAPHRAGM	BACK-UP DIAPHRAGM	ULTRA-FLEX™ DIAPHRAGM	SIP DIAPHRAGM
XSD1-½ SANIFLO HS EQUALIZER®	FDA NITRILE	04-1010-69	N/A	04-1020-52	N/A
	FDA EPDM	04-1010-74	04-1060-54	04-1020-54	N/A
	PTFE	04-1010-55	N/A	N/A	04-1030-72
XSD2 SANIFLO HS EQUALIZER®	FDA NITRILE	04-1010-69	N/A	04-1020-52	N/A
	FDA EPDM	04-1010-74	04-1060-54	04-1020-54	N/A
	PTFE	04-1010-55	N/A	N/A	04-1030-72
XSD3 SANIFLO HS EQUALIZER®	FDA NITRILE	08-1010-69	N/A	08-1020-52	N/A
	FDA EPDM	08-1010-74	08-1060-54	08-1020-54	N/A
	PTFE	08-1010-55	N/A	N/A	08-1030-72

CERTIFICATE OF COMPLIANCE

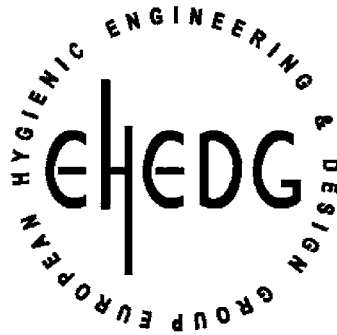

TNO Certification
hereby declares that the product

Air operated double Diaphragm Pump type Saniflo HS size 1.0" to 3.0"

From

Wilden Pump & Engineering, LLC, Grand Terrace, USA

has been evaluated for compliance with the Hygienic Equipment Design Criteria
of the EHEDG, Document No. 8, by:

TNO Quality of Life at Zeist, Netherlands
and meets the criteria of this document as demonstrated by:

Evaluation Report No. V6621RE

Signed [Signature]
Evaluation Officer

Date June 15, 2006

Signed [Signature]
Managing Director, TNO Certification

Date June 15, 2006



Certificate No. C06-8337

TNO Certification BV, P.O. Box 541, 7300 AM Apeldoorn, Netherlands
©EHEDG

WARRANTY

Each and every product manufactured by Wilden Pump and Engineering, LLC is built to meet the highest standards of quality. Every pump is functionally tested to insure integrity of operation.

Wilden Pump and Engineering, LLC warrants that pumps, accessories and parts manufactured or supplied by it to be free from defects in material and workmanship for a period of five (5) years from date of installation or six (6) years from date of manufacture, whichever comes first. Failure due to normal wear, misapplication, or abuse is, of course, excluded from this warranty.

Since the use of Wilden pumps and parts is beyond our control, we cannot guarantee the suitability of any pump or part for a particular application and Wilden Pump and Engineering, LLC shall not be liable for any consequential damage or expense arising from the use or misuse of its products on any application. Responsibility is limited solely to replacement or repair of defective Wilden pumps and parts.

All decisions as to the cause of failure are the sole determination of Wilden Pump and Engineering, LLC.

Prior approval must be obtained from Wilden for return of any items for warranty consideration and must be accompanied by the appropriate MSDS for the product(s) involved. A Return Goods Tag, obtained from an authorized Wilden distributor, must be included with the items which must be shipped freight prepaid.

The foregoing warranty is exclusive and in lieu of all other warranties expressed or implied (whether written or oral) including all implied warranties of merchantability and fitness for any particular purpose. No distributor or other person is authorized to assume any liability or obligation for Wilden Pump and Engineering, LLC other than expressly provided herein.

PLEASE PRINT OR TYPE AND FAX TO WILDEN

PUMP INFORMATION			
Item # _____		Serial # _____	
Company Where Purchased _____			
YOUR INFORMATION			
Company Name _____			
Industry _____			
Name _____		Title _____	
Street Address _____			
City _____		State _____	Postal Code _____
Country _____			
Telephone _____		Fax _____	E-mail _____
Web Address _____			
Number of pumps in facility? _____		Number of Wilden pumps? _____	
Types of pumps in facility (check all that apply): <input type="checkbox"/> Diaphragm <input type="checkbox"/> Centrifugal <input type="checkbox"/> Gear <input type="checkbox"/> Submersible <input type="checkbox"/> Lobe			
<input type="checkbox"/> Other _____			
Media being pumped? _____			
How did you hear of Wilden Pump? <input type="checkbox"/> Trade Journal <input type="checkbox"/> Trade Show <input type="checkbox"/> Internet/E-mail <input type="checkbox"/> Distributor			
<input type="checkbox"/> Other _____			

ONCE COMPLETE, FAX TO (909) 783-3440

NOTE: WARRANTY VOID IF PAGE IS NOT FAXED TO WILDEN
WILDEN PUMP & ENGINEERING, LLC

Order Online: www.PumpCatalog.com

PSG® Brands

ABAQUE®
PERISTALTIC PUMPS
mouvex.com

MAAG
PUMP SYSTEMS
EXTRUSION PUMPS & SYSTEMS
maag.com

ALMATEC®
AIR-OPERATED
DOUBLE-DIAPHRAGM PUMPS
almatec.de

MOUVEX®
ECCENTRIC DISC PUMPS,
VANE PUMPS &
COMPRESSORS
mouvex.com

AUTOMATIK
PELLETIZING SYSTEMS
maag.com

NEPTUNE™
DIAPHRAGM (METERING) PUMPS,
POLYMER SYSTEMS & MIXERS
neptune1.com

BLACKMER®
VANE PUMPS & COMPRESSORS
blackmer.com

QUATTROFLOW™
QUATERNARY DIAPHRAGM
PUMP TECHNOLOGY
quattroflow.com

FLUID DYNAMICS™
POLYMER BLENDING SYSTEMS
fluiddynamics1.com

REDSCREW™
SCREW PUMPS
redscrowpump.com

GRISWOLD™
CENTRIFUGAL PUMPS
griswoldpump.com

SYSTEM ONE®
CENTRIFUGAL PUMPS
blackmer.com

MAAG
FILTRATION
PLASTIC MANUFACTURING &
PROCESSING FILTRATION
maag.com

WILDEN®
AIR-OPERATED
DOUBLE-DIAPHRAGM PUMPS
wildenpump.com

MAAG
INDUSTRIAL PUMPS
GEAR & SCREW PUMPS
maag.com



Where Innovation Flows

WILDEN®
Part of Pump Solutions Group
A **DOVER** COMPANY

22069 Van Buren St.
Grand Terrace, CA 92313-5651
T: +1 (909) 422-1731
F: +1 (909) 783-3440

PSG reserves the right to modify the information and illustrations contained in this document without prior notice. This is a non-contractual document. 10-2013

Authorized PSG Representative:

Copyright 2013, Pump Solutions Group (PSG), A Dover Company