

Please read and save this Repair Parts Manual. Read this manual and the General Operating Instructions carefully before attempting to assemble, install, operate or maintain the product described. Protect yourself and others by observing all safety information. The Safety Instructions are contained in the General Operating Instructions. Failure to comply with the safety instructions accompanying this product could result in personal injury and/or property damage! Retain instructions for future reference. AMT reserves the right to discontinue any model or change specifications at any time without incurring any obligation.

©2013 American Machine & Tool Co., Inc. of PA, A Subsidiary of The Gorman-Rupp Company, All Rights Reserved.

Periodic maintenance and inspection is required on all pumps to ensure proper operation. Unit must be clear of debris and sediment. Inspect for leaks and loose bolts. Failure to do so voids warranty.

# Centrifugal Laundry Tray Pump

Refer to pump manual 1808-634-00 for General Operating and Safety Instructions.

A Gorman-Rupp Company

## DESCRIPTION

This centrifugal laundry tray pump is designed for gravity-feed pumping operations. Unit can handle laundry water or other nonflammable, non abrasive fluids compatible with pump construction. Pump is equipped with mechanical seal (carbon face with Buna-N seal cartridge), cast aluminum body and impeller, and a split-phase motor. This is a manual unit, no controls are supplied. Unit does not come supplied with any type of switch or control device to turn unit on or off.

## INSTALLATION

Refer to Figure 1 and proceed as follows:

1. Locate pump as close to the laundry tub as possible. Support the pump and piping adequately to keep pump and piping from being strained.
2. Pitch the piping from tub drain to pump suction to avoid air traps. (Do not use the conventional trap). Keep the pipe-size at least 1 1/4". Use pipe dope to avoid joint leakage. Install necessary piping for pressure switches or any other control devices (not supplied). Follow manufacturer's instructions for their installation.
3. Install a check valve on the discharge side to prevent drain-back.
4. Locate check valve below level of bottom of tub.
5. Wire motor by following wiring diagram on nameplate. It is strongly recommended that this unit is plugged into a GFCI (Ground Fault Circuit Interrupter). Consult your local electrician for installation and availability. Be sure unit is grounded (General Safety Information). If unit is to be controlled by an on and off switch, install at this time.
6. If laundry water from a washer is discharged into the laundry tub, it should be filtered. Filtering can be accomplished many ways. An easy way is by taking an old pair of panty hose, putting one leg into the other, and then putting it on the end of the washer discharge hose with a rubber band. Most of the panty hose should be lying in the laundry tub. Eventually, the panty hose will become full of lint and a hole will develop. The panty hose should then be replaced.
7. Installation is now complete.

**NOTE:** To prevent accidents, locate motor in a suitable (ventilated) enclosure, or guard all moving parts and ventilation openings.

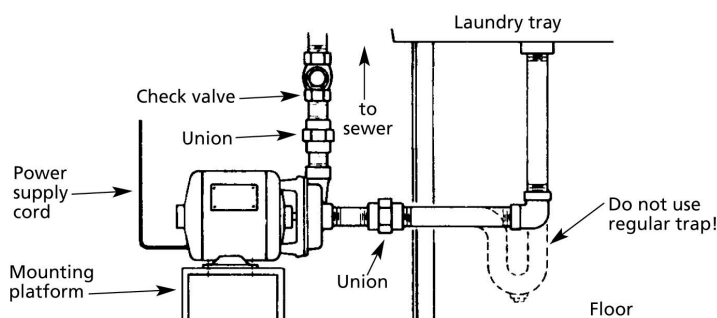

Figure 1 - Typical Installation

## OPERATION

Turn unit on by either plugging pump in, turning switch on, or if unit is installed with an automatic device, (not supplied) it will activate itself as well as turn itself off. On units without automatic devices, it is necessary to shut pump off when water stops draining out of the tub (last couple of inches). The pump has become air bound. After a few seconds, when the water has gone down, turn unit on again. The unit may have to be turned on and off a few times to completely drain tub. This is normal. When water has been completely pumped out of the tub, turn pump off immediately.

## MAINTENANCE

### **▲ WARNING**

**Disconnect from power source before servicing or inspecting the pump for any reason. Failure to do so could result in fatal electrical shock!**

### MOTOR

Dirt accumulations can cause motor overheating and a fire hazard. Remove dirt accumulations from the motor, especially in and around vent openings by vacuuming.

Periodically inspect the installation. Check for dirt accumulations; unusual noises or vibration; overheating; worn or loose couplings, sheaves and belts; high motor current; poor wiring or overheating connections; loose mounting bolts or guards.

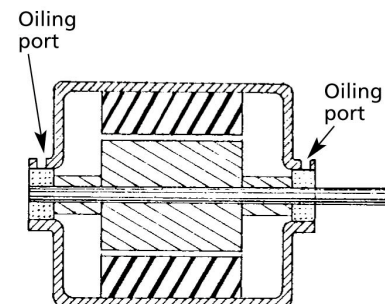

Figure 2 - Location of Bearings

# Centrifugal Laundry Tray Pump

The motor used with this pump uses sleeve bearings which require periodic reoiling. Each motor has two bearings, which should be lubricated once a year. The bearings are located around the motor shaft (See Figure 2), at each end of the motor. The oil reservoirs have plastic plugs covering them. Pull out the plugs and put oil in. Replace plugs after oiling.

Follow re-oiling instructions on the motor (see nameplate or terminal box cover). If instructions are not included, re-oil once a year with 30-35 drops of SAE No. 20 non-detergent or electric motor oil. Do not over-lubricate.

## PUMP

There is no normal pump maintenance. Some work might be required on the pump when output has been reduced or when seal leaks. This can be caused by lint build-up around the impeller. Disassemble pump (See Mechanical Seal Replacement), remove impeller (Ref. No. 5) and clean out, then re assemble.

## MECHANICAL SEAL REPLACEMENT

After pump has been in service for a long period of time, or if pump has been in severe service, it may be necessary to replace shaft seal assembly (Ref. No. 3 & 4). Leakage can be detected by a dripping or flow of liquid from area around motor shaft (Ref. No. 1).

### ⚠ CAUTION

The precision lapped faces on shaft seal assembly are easily damaged. Handle your replacement seal carefully and read these instructions before attempting to replace seal.

Refer to Figure 5 for Parts Illustration.

1. Disassemble casing (Ref. No. 8) and casing seal (Ref. No. 7) from adapter (Ref. No. 2) by removing fasteners (Ref. No. 9).
2. Notice the location of impeller (Ref. No. 5) on shaft. It should be compressing seal cartridge (Ref. No. 3). Loosen fastener (Ref. No. 6) and impeller will slide off shaft.
3. Pry seal seat (Ref. No. 4) from impeller recess with a small screwdriver (see Figure 3).

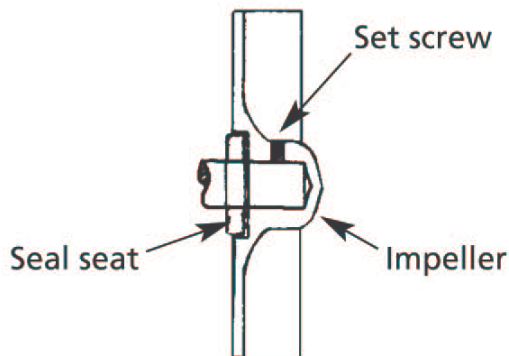

Figure 3 - Mechanical Seal

4. Press old seal cartridge out of adapter by pushing from motor side.

**NOTE:** Use a 1 1/4" pipe or a socket from a tool set.

5. Clean adapter seal cavity before inserting new seal cartridge.
6. Carefully wipe polished surface of new seal seat with a clean cloth.
7. Wet the rubber portion of seal seat with a light coating of soapy water.
8. Press seal seat squarely into cavity in impeller as illustrated. If seal seat does not press squarely into cavity, it can be adjusted in place by pushing on it with a piece of pipe. Always use a piece of cardboard between pipe and seal seat to avoid scratching seal seat. This is a lapped surface and must be handled very carefully.
9. After seal seat is in place, check that it is clean and has not been scratched or cracked.
10. Replace seal cartridge. A sealing compound (such as silicon or Permatex) may be used to insure a water tight fit on outside of cartridge.
11. Mount adapter on motor mounting face.
12. Replace impeller, tightening it securely with fastener in approximately same position it had been before disassembly. (See Step 2).
13. Make sure casing seal is in place on adapter.
14. Replace casing, tightening securely with fasteners.

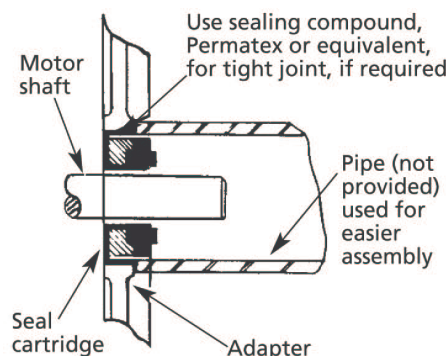

Figure 4 - Mechanical Seal

## ROUTINE

Pump should be checked daily, weekly, monthly, etc. for proper operation. If anything has changed since unit was new, unit should be removed and repaired or replaced. Only qualified electricians or service personnel should attempt to repair this unit. Improper repair and/or assembly can cause an electrical shock hazard.

# Centrifugal Laundry Tray Pump

**For Repair Parts contact dealer where pump was purchased.**

Please provide following information:

-Model Number

-Serial Number (if any)

Part description and number as shown in parts list

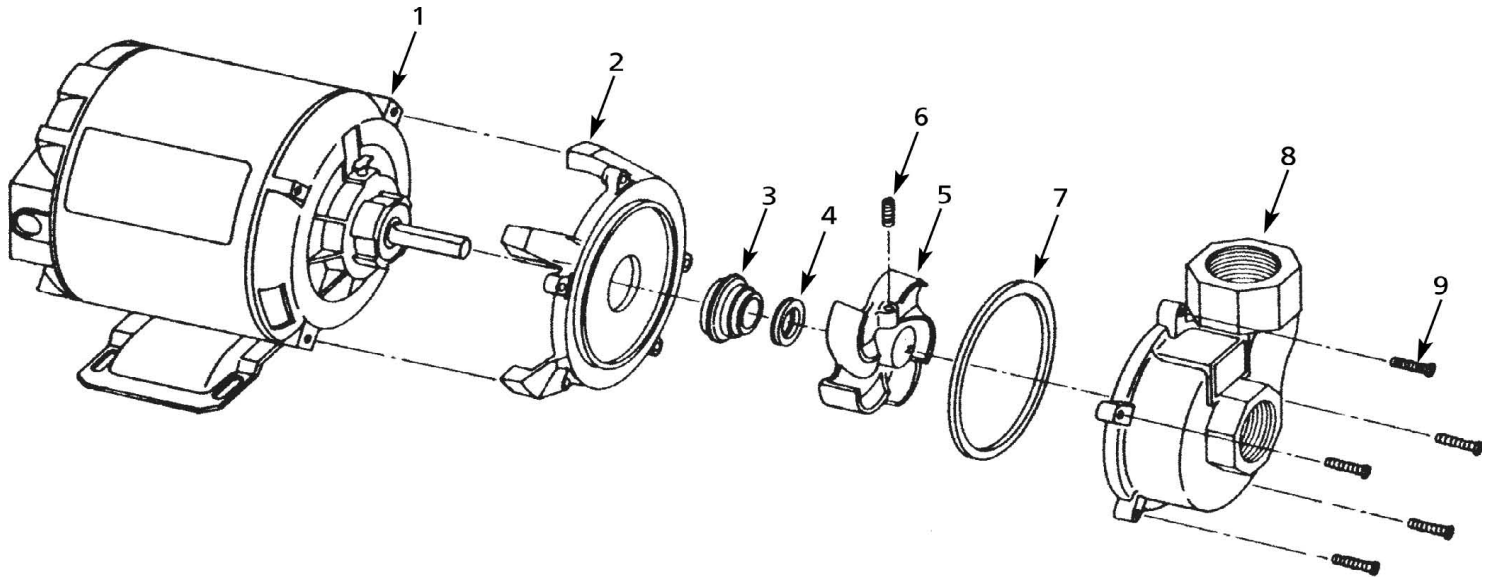

Figure 5 - Repair Parts Illustrations

## Repair Parts List

Ref No.	Description	Part Number for 3201-96	Qty
1	Motor	1626-048-00	1
2	Adapter	3200-030-96	1
3 & 4	Shaft Seal Assembly - Buna N	1640-161-93	1
5	Impeller Kit (includes Ref. Nos. 5 and 6)	3200-010-96	1
6	Fastener	Incl. w/Ref 5	1
7	O-Ring Kit - Buna N	3200-300-90	1
8	Casing Kit (includes Ref. Nos. 8 and 9)	3200-001-96	1
9	Fastener	Incl. w/Ref 8	5



American Machine & Tool Co., Inc. of PA  
(herein "AMT")  
400 Spring Street  
Royersford, PA 19468  
Phone: (610) 948-3800  
Fax: (610) 948-5300  
www.amtpump.com

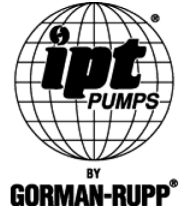

## General Information

**SALES POLICY:** AMT products are sold through our established Distributors. We do not sell direct to the consumer or organization not entitled to trade recognition. Therefore, possession of our catalogs and/or price list(s) does not infer an offer to sell.

**MINIMUM ORDER:** We appreciate your order, however, all orders are subject to a minimum \$35.00 net invoice charge (excluding freight). This applies to all pump and parts purchase orders.

**PRICES:** Prices are subject to change without notice. All orders accepted are subject to prices in effect at time of shipment.

**PAYMENT TERMS:** Terms, upon establishment of credit, are Net 30 days. Past due accounts may be subject to a service charge of 1.5% per month. Domestic or assignable letter of credit is required for all export trade.

**PAST DUE ACCOUNTS:** AMT reserves the right to withhold open account shipments on any past due account. Invoices are considered past due after thirty (30) days. In the interest of sound business, all orders are subject to approval of the Credit Department.

**SHIPPING INSTRUCTIONS:** All shipments will be made F.O.B. the factory. Where instructions for shipment do not appear on the order, the shipment will be made according to our best judgment. Full risk of loss (including transportation delays and losses) shall pass to the customer upon delivery of the products to the carrier at the F.O.B. point. When loss or delay occurs, primary responsibility for tracing rests with the customer. When there is LOSS or APPARENT VISIBLE DAMAGE to a shipment, when tendered for delivery, *DO NOT* give the carrier a clear receipt. Note such damage on the carrier's delivery receipt and *HAVE THE DRIVER SIGN THE RECEIPT.*

**PRODUCT REVISIONS:** AMT reserves the right to discontinue, change or improve its products or any portions thereof without being obligated to provide such a change or improvement for units sold and/or shipped prior to such a change or improvement.

**LEAD TIME:** Products designated "Quick Ship Product", also referred to as "QSP" will normally be shipped within 24 hours of receipt of a non-cancellable purchase order. Only limited quantities of "QSP" pumps are available.

**STANDARD LEAD TIME:** Lead time is two weeks for all non "QSP" product. AMT reserves the right to revise lead times as required due to availability of materials and all other causes beyond our control.

**VIP SHIPMENT:** Select AMT and IPT branded pumps are available for next day shipment for non-QSP (Quick Ship Products) items and subjected to a specific model surcharge per unit noted in the respective price book. Requires calling for availability, confirmation and a non-cancellable purchase order or credit card payment prior to shipment. The expedited shipping charges are an additional cost added separately from the VIP charges per item. AMT reserves the right to revise lead times as required due to availability of materials and all other causes beyond our control. QSP quantities are limited as determined by AMT.

ALL purchase orders must be submitted via hard copy sent to AMT customer service department by fax, EDI or e-mail.

**RETURN GOODS POLICY:** Goods shall not be returned without a return goods authorization number (RGA) issued by AMT customer service. The RGA number must be listed on the packing list. Only current model and part numbers with a valid date code may be returned (within one year from date of purchase). **A 20% restocking and packaging charge will apply to all returns. All shipping charges must be pre-paid. No exceptions.**

**ORDER CHANGES BY CUSTOMER:** Orders in process may not be changed except with written consent and may be subject to special charges.

## 12 Month Limited Warranty

### EXTENT AND DURATION OF LIMITED WARRANTY

**Coverage:** American Machine & Tool Company (herein "AMT") or IPT Pumps by Gorman-Rupp (herein "IPT") or Gorman-Rupp Industries Division of The Gorman-Rupp Company, Patterson, or the Gorman-Rupp Company (herein referred to as "G-R Unit") each individually warrants that its products and parts shall be free from defects in material and workmanship for twelve (12) months from the date of purchase by the original end user when installation is made and maintenance is performed in accordance with G-R Unit's recommendations. Wear and tear resulting from use and items normally consumed in use are not covered.

### EXCEPTIONS

( A ) This Limited Warranty shall not apply to mechanical seals in AMT or IPT pumps and the following products and parts: engines, motors, trade accessories and all other products, components, parts and materials not manufactured by the G-R Units. These items may, however, be covered by the warranties of their respective manufacturers. ( B ) This warranty does not extend to or apply to any unit which has been repaired or altered at any place other than by a G-R Unit, or by persons not expressly approved by a G-R Unit to make repairs or alterations, nor to any unit the serial number, model number or identification of which has been removed, defaced or altered. ( C ) This warranty does not extend to any product manufactured by a G-R Unit, which has been subjected to mis-use, neglect, accident, improper installation, or use in violation of instructions furnished by a G-R Unit. ( D ) Pump Kits: This warranty does not extend to any product sold by a G-R Unit unassembled as a Pump Kit. Pump Kits are warranted against defects in material and workmanship for 60 days from the date of shipment from a G-R Unit. Any Pump Kit parts deemed defective by a G-R Unit will be replaced free of charge within 60 days of shipment. Pump Kits are not returnable for credit.

### LIMITATIONS

**THE G-R UNITS' SOLE AND EXCLUSIVE WARRANTY WITH RESPECT TO THEIR PRODUCTS AND PARTS IS THIS LIMITED WARRANTY. THIS LIMITED WARRANTY IS IN LIEU OF ALL OTHER EXPRESS AND/OR IMPLIED WARRANTIES, INCLUDING IMPLIED WARRANTIES OF MERCHANTABILITY AND FITNESS FOR PARTICULAR PURPOSE.**

### EXCLUSIVE REMEDY AND DAMAGES

The sole and exclusive remedy for breach of this Warranty by a G-R Unit and the entire extent of its liability for such breach or for damages arising from the use of the products and parts covered under this Limited Warranty, shall be as follows:

- Repair or Replacement:** If inspection shows that any G-R Unit product or part covered under this Limited Warranty is defective in materials or workmanship, the G-R Unit shall repair or replace the defective or non-conforming product or part without charge, whichever the G-R Unit chooses. You must have properly maintained and used the product or part claimed to be defective in accordance with the maintenance schedule or manual, which comes with the product. No allowance will be made for labor, installation, removal, transportation or other charges incurred by you in connection with such repair or replacement.
- To obtain the above remedy:
  - Immediately notify the G-R Unit upon discovery of the claimed defect in materials or workmanship and provide the serial number or date code of the product and/or part(s) or provide the G-R Unit with the invoice or bill of sale referencing the product by no later than the expiration date of the warranty period.
  - The G-R Unit will advise whether inspection will be necessary and how whether repair or replacement will be made. If inspection by the G-R Unit is necessary, the pump or defective part must be sent freight pre-paid to the G-R Unit. Return shipment will be F.O.B. the G-R Unit's plant.
  - Return Goods Authorization Requirement:** No product will be accepted for return or replacement without the prior written authorization of the G-R Unit. Upon such authorization, and in accordance with instructions from the G-R Unit, the product will be returned to the G-R Unit, shipping charges prepaid by the Buyer.
- Damages:** The G-R Unit's liability for damages for breach of this Limited Warranty shall not exceed the amount of the purchase price of the product or part(s) in respect to which Such damages are claimed. **IN NO EVENT SHALL THE G-R UNITS BE LIABLE FOR INCIDENTAL, CONSEQUENTIAL OR SPECIAL DAMAGES FOR BREACH OF THIS LIMITED WARRANTY.**

Some states do not allow the exclusion or limitation of incidental or consequential damages, so the above limitation or exclusion may not apply to you. This Limited Warranty gives you specific legal rights, and you may also have other rights, which vary from state to state.