

# **BALDOR® • RELIANCE**

## **Product Information Packet**

# **CEM7057T-I**

**15//10 NEMA MG-1 PT.5,IP55HP,1175//985**

Part Detail							
Revision:	-	Status:	PRD/A	Change #:		Proprietary:	No
Type:	AC	Prod. Type:	1046M	Elec. Spec:	10WGY561	CD Diagram:	CD0180
Enclosure:	XPFC	Mfg Plant:		Mech. Spec:	10E949	Layout:	10LYE949
Frame:	284TC	Mounting:	F1	Poles:	06	Created Date:	04-22-2016
Base:	RG	Rotation:	R	Insulation:	F	Eff. Date:	05-02-2016
Leads:	9#10					Replaced By:	
Literature:		Elec. Diagram:					

Nameplate NP0977XPSLEV										
NO.							CC	010A		
SER.							TEMP CODE	T3C		
SPEC.	10E949Y561G1									
CAT.NO.	CEM7057T-I									
HP	15//10 NEMA MG-1 PT.5,IP55									
VOLTS	230/460//190/380									
AMPS	42/21//36/18									
RPM	1175//985						MOTOR WEIGHT	478		
HERTZ	60//50		PH	3	CL	F	DE BRG	6311		
SER.F.	1.15		DES	A	CODE	H	ODE BRG	6309		
FRAME	284TC		GREASE	POLYREX EM						
RATING	40C AMB-CONT									
USABLE AT 208V	42		NEMA-NOM-EFF			91.7		PF	73	
	55C AMB @ 1.0 SF,60C RISE									

Parts List		
Part Number	Description	Quantity
SA319388	SA 10E949Y561G1	1.000 EA
RA307081	RA 10E949Y561G1	1.000 EA
09FN3001B02	EXTERNAL FAN, PLASTIC	1.000 EA
12CB1003A02	CONDUIT BOX MACH. GROUP C MTRS	1.000 EA
10XN3118K24	5/16-18 X 1.50" HEX HD, GRADE 5	4.000 EA
HW1001A31	LOCKWASHER 5/16, ZINC PLT.591 OD, .319 I	4.000 EA
WD1000B19	TERMINAL BURNDY L250HP	1.000 EA
10XN3816K12	3/8-16 X 3/4 HEX HD CAP GRADE 5	1.000 EA
HW1001A38	LOCKWASHER 3/8, ZINC PLT .688 OD, .382 I	1.000 EA
10EP1701A25P	FR ENDPLATE, MACH W/PRIMER	1.000 EA
HW4505A02	BREATHER/DRAIN-EXP PROOF-.250-18 PTF AIS	1.000 EA
HW3023E06	.125 X .625 SPIRAL SPRING PIN	1.000 EA
HA3050A03	3/8-16 X 2.25" GRADE 8 BOLT	4.000 EA
HW1001A38	LOCKWASHER 3/8, ZINC PLT .688 OD, .382 I	4.000 EA
HW5100A11	W3917-042 WVY WSHR (WB)	1.000 EA
10XN2520K40	1/4-20 X 2-1/2 HEX HD CAPSCREW, GRADE 5,Z	4.000 EA
HW1001A25	LOCKWASHER 1/4, ZINC PLT .493 OD, .255 I	4.000 EA
10EP1710A09P	FACE MTD. EP MACH XPFC W/HW4505A02 W/PRI	1.000 EA
HW4505A02	BREATHER/DRAIN-EXP PROOF-.250-18 PTF AIS	1.000 EA
HW3023E06	.125 X .625 SPIRAL SPRING PIN	1.000 EA
HA3050A03	3/8-16 X 2.25" GRADE 8 BOLT	4.000 EA
HW1001A38	LOCKWASHER 3/8, ZINC PLT .688 OD, .382 I	4.000 EA
HA2067A01	ALUM SLINGER (AUTO)	1.000 EA
80XN1032A06	10-32 X 3/8 SET SC HEX SOCK	2.000 EA

<b>Parts List (continued)</b>		
<b>Part Number</b>	<b>Description</b>	<b>Quantity</b>
10FH1008A01	310 FAN HOUSING X-PROOF MACH.	1.000 EA
WD4100A42	CAPLUG BPF-3/4, FOR 1/2" NPT OR 3/4 HOLE	1.000 EA
10XN3118K12	5/16-18 X .75 GRADE 5, ZINC PLATED	3.000 EA
HW1001A31	LOCKWASHER 5/16, ZINC PLT.591 OD, .319 I	3.000 EA
12CB1502A01	CONDUIT BOX LID MACH. GROUP C MTRS	1.000 EA
84XN5013J32	SOCKET HD.CAP SCR,1/2-13 X 2"LG,ALLOY ST	10.000 EA
HW1001A50	LOCKWASHER 1/2, ZINC PLT.,.879 OD, .509 I	10.000 EA
HW2501H28	KEY, 1/2 SQ X 3.250	1.000 EA
LB1115N	LABEL,LIFTING DEVICE (ON ROLLS)	1.000 EA
LB1081C	ALUM XP CAUTION LABEL (COL PLANT ONLY-	1.000 EA
WD4100A03	DE-750 HEYCO PLUG 62MP0750 MICRO PLASTIC	1.000 EA
HW4500A20	1/8NPT SL PIPE PLUG	2.000 EA
MJ1000A02	GREASE, POLYREX EM EXXON (USe 4824-15A)	0.130 LB
HW4500A20	1/8NPT SL PIPE PLUG	2.000 EA
HW2500A25	WOODRUFF KEY USA #1008 #BLOW CARBON STEE	1.000 EA
51XB1214A20	12-14X1.25 HXWSSLD SERTYB	1.000 EA
MG1025G05	WILKOFASST, 789.227, MED. GRAY CHAR. MET.	0.125 GA
85XU0407S04	4X1/4 U DRIVE PIN STAINLESS	6.000 EA
LB1119N	WARNING LABEL	1.000 EA
LC0181	CONNECTION LABEL	1.000 EA
NP0977XPSLEV	SS XP UL CSA-EEV CC CL-I GP-C&D	1.000 EA
14PA1000	PACKAGING 314 GROUP COMBINED PRINT	1.000 EA
MN416A01	TAG-INSTAL-MAINT no wire (1200/bx) 11/14	1.000 EA

**AC Induction Motor Performance Data**

Record # 56745 - Typical performance - not guaranteed values

<b>Winding:</b> 10WGY561-R033	<b>Type:</b> 1046M	<b>Enclosure:</b> XPFC
-------------------------------	--------------------	------------------------

Nameplate Data				460 V, 60 Hz: High Voltage Connection	
Rated Output (HP)	15//10			Full Load Torque	66.5 LB-FT
Volts	230/460//190/380			Start Configuration	direct on line
Full Load Amps	42/21//36/18			Breakdown Torque	195 LB-FT
R.P.M.	1175//985			Pull-up Torque	91.4 LB-FT
Hz	60//50	Phase	3	Locked-rotor Torque	115 LB-FT
NEMA Design Code	A	KVA Code	H	Starting Current	125 A
Service Factor (S.F.)	1.15			No-load Current	11.3 A
NEMA Nom. Eff.	91.7	Power Factor	73	Line-line Res. @ 25°C	0.56099 Ω
Rating - Duty	40C AMB-CONT			Temp. Rise @ Rated Load	49°C
S.F. Amps				Temp. Rise @ S.F. Load	59°C
				Locked-rotor Power Factor	33.4
				Rotor inertia	5.63 LB-FT <sup>2</sup>

Load Characteristics 460 V, 60 Hz, 15 HP

% of Rated Load	25	50	75	100	125	150	S.F.
Power Factor	34	54	66	73	76	77	75
Efficiency	85	90.6	91.8	92	91.5	91.3	91.7
Speed	1197	1193	1188.7	1183.9	1179	1177.5	1181
Line amperes	12.2	14.3	17.3	20.8	25.1	26.1	23.4

Performance Graph at 460V, 60Hz, 15.0HP Typical performance - Not guaranteed values

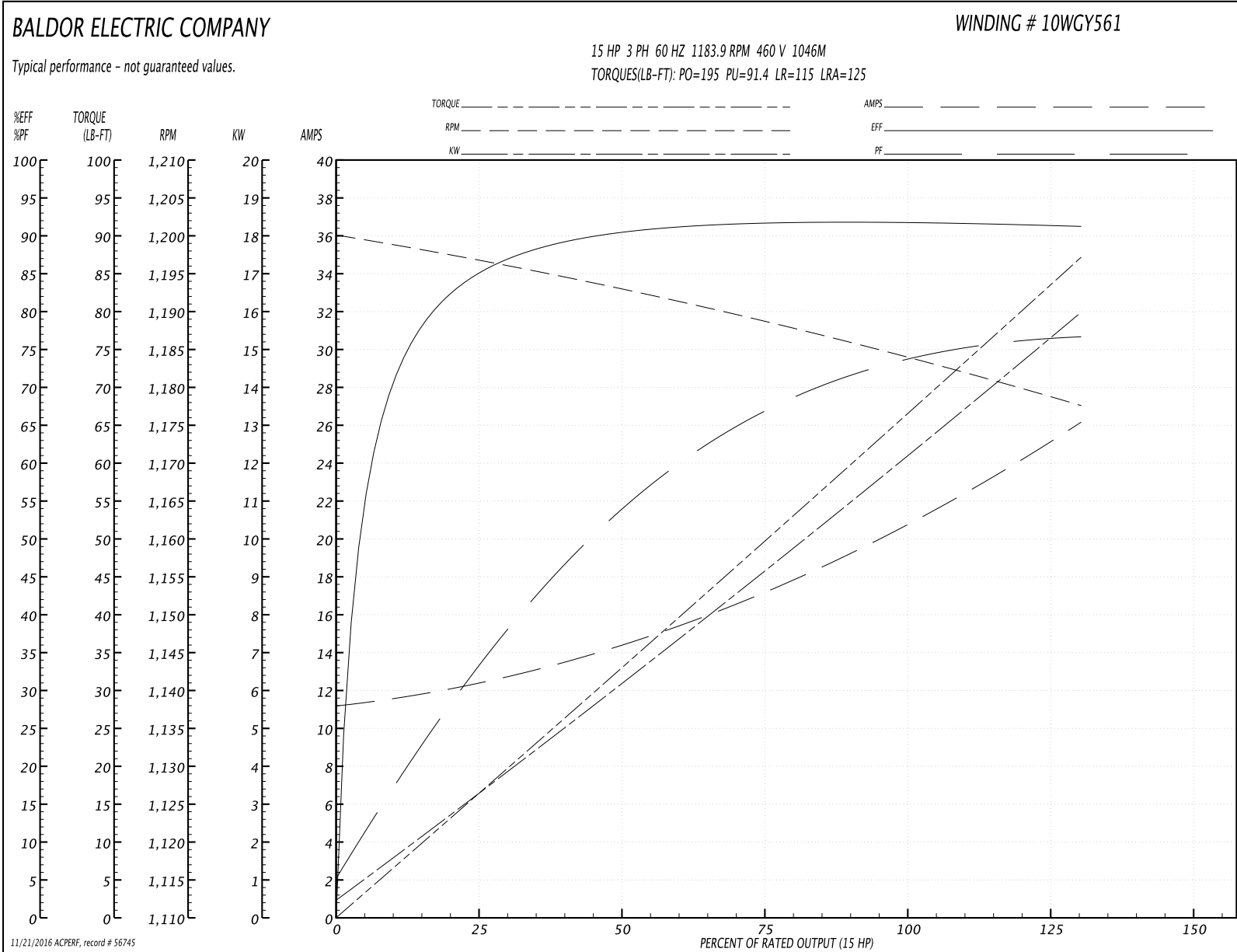

**AC Induction Motor Performance Data**

Record # 56746 - Typical performance - not guaranteed values

<b>Winding:</b> 10WGY561-R033	<b>Type:</b> 1046M	<b>Enclosure:</b> XPFC
-------------------------------	--------------------	------------------------

Nameplate Data				380 V, 50 Hz: High Voltage Connection	
Rated Output (HP)	15//10			Full Load Torque	53.2 LB-FT
Volts	230/460//190/380			Start Configuration	direct on line
Full Load Amps	42/21//36/18			Breakdown Torque	187 LB-FT
R.P.M.	1175//985			Pull-up Torque	93.9 LB-FT
Hz	60//50	Phase	3	Locked-rotor Torque	118 LB-FT
NEMA Design Code	A	KVA Code	H	Starting Current	121 A
Service Factor (S.F.)	1.15			No-load Current	11 A
NEMA Nom. Eff.	91.7	Power Factor	73	Line-line Res. @ 25°C	0.521 Ω
Rating - Duty	40C AMB-CONT			Temp. Rise @ Rated Load	39°C
S.F. Amps				Temp. Rise @ S.F. Load	45°C
				Locked-rotor Power Factor	37
				Rotor inertia	5.63 LB-FT <sup>2</sup>

Load Characteristics 380 V, 50 Hz, 10 HP

% of Rated Load	25	50	75	100	125	150	S.F.
Power Factor	30	48	60	69	73	74	71
Efficiency	81.1	88.5	90.3	90.8	90.7	90.7	90.7
Speed	998	994	991	987	983	982	985
Line amperes	11.7	13.3	15.6	18.2	21.4	21.9	20.1

Performance Graph at 380V, 50Hz, 10.0HP Typical performance - Not guaranteed values

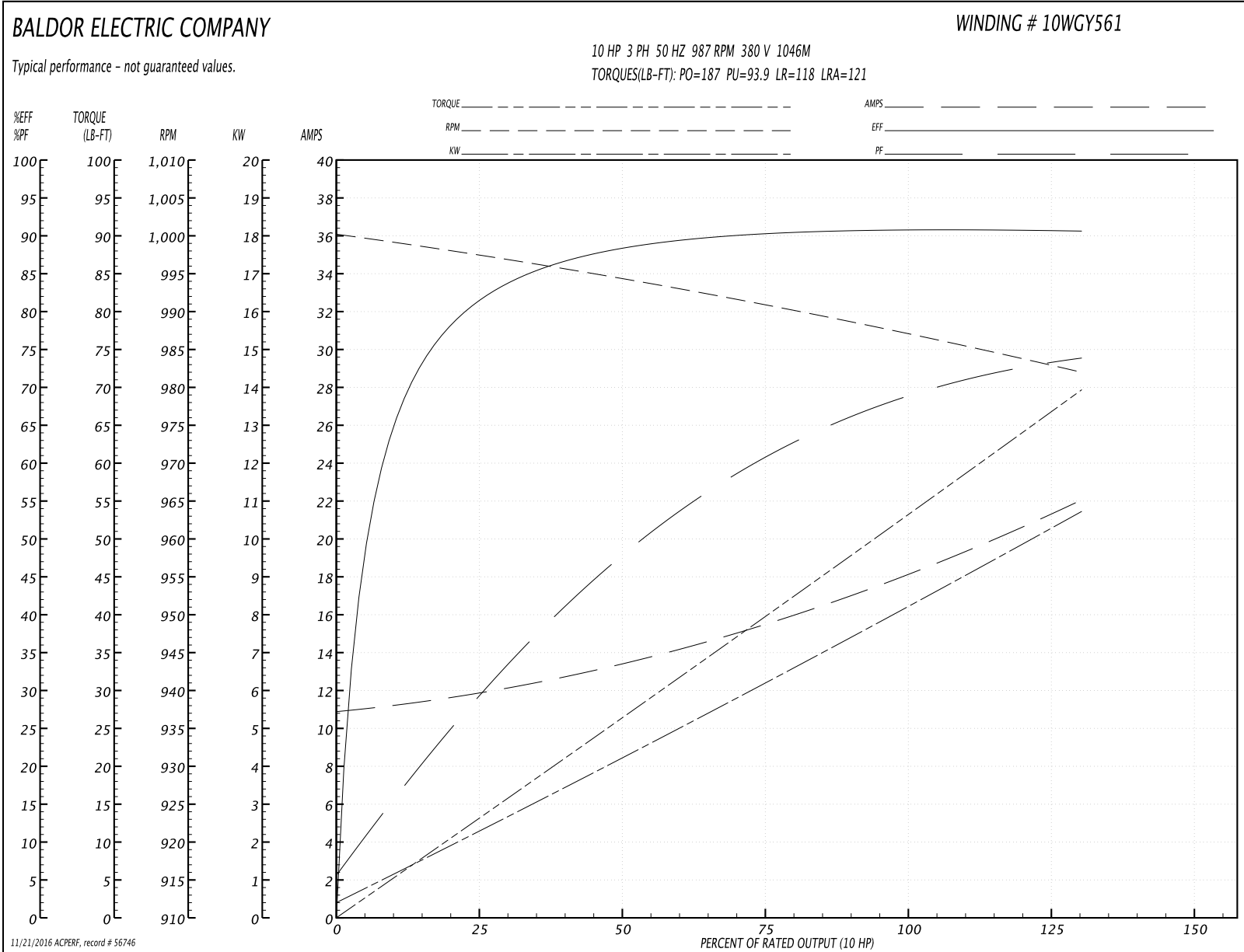

10L YE949

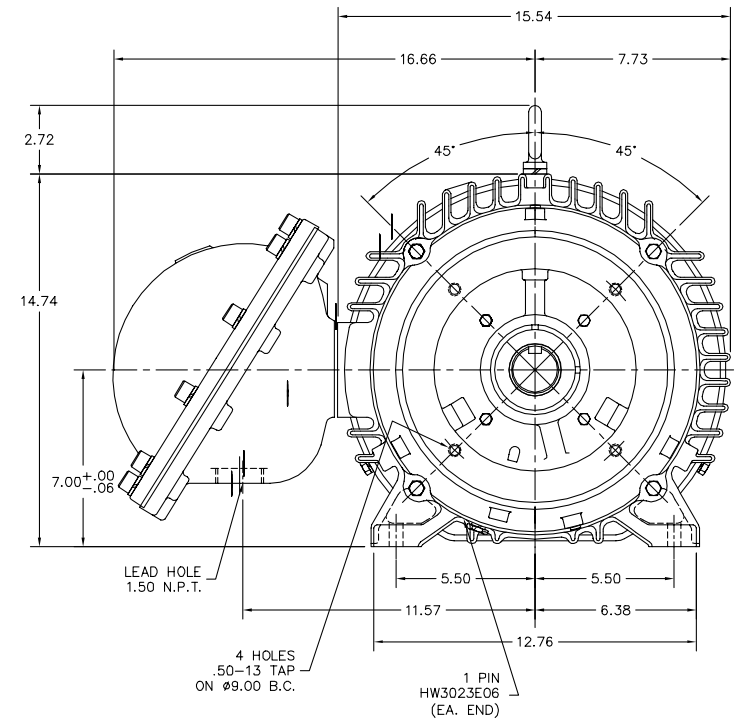
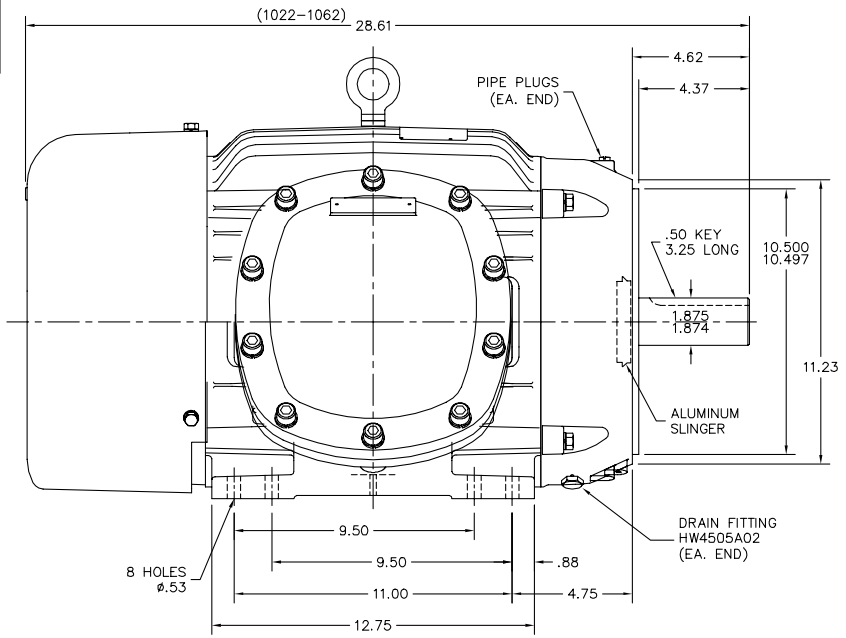

10L YE949

CUSTOMER IS RESPONSIBLE FOR DETERMINING THAT BALDOR'S PRODUCT WILL PERFORM SUITABLY IN THE INTENDED APPLICATION.

REV. DESC: UPDATE STACK RANGES TO (1022-1062)		
REV. LTR: D	VERSION: 02	TDR: 000000579194
FILE: \AAA\00076\041	REVISED: 03:39:56 02/09/2011	BY: ENTYLLO
MTL: -		

**BALDOR**

HORZ XPFC 284-6TC CL1, GRP. C&D ONLY, DRILL RIG

SH 1 of 1

CD0180

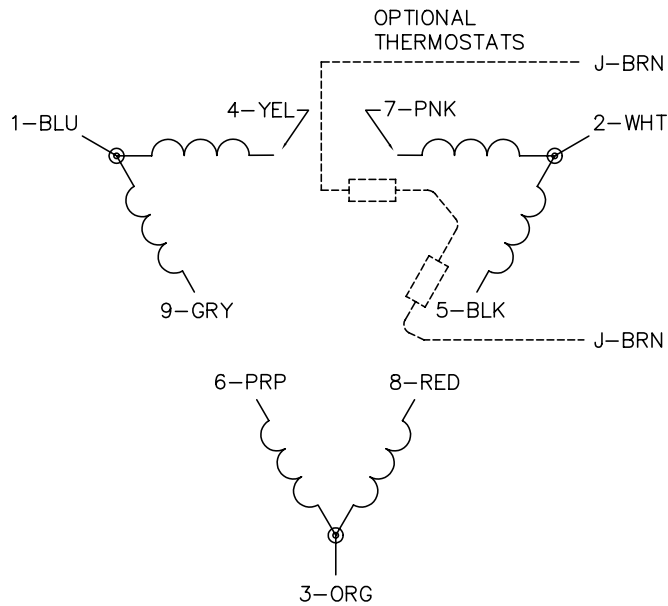

LOW VOLTAGE  
(2D)

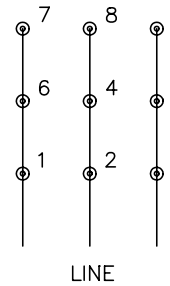

HIGH VOLTAGE  
(1D)

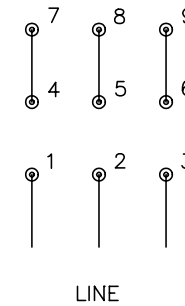

NOTES:

1. INTERCHANGE ANY TWO LINE LEADS TO REVERSE ROTATION.
2. OPTIONAL THERMOSTATS ARE PROVIDED WHEN SPECIFIED.
3. ACTUAL NUMBER OF INTERNAL PARALLEL CIRCUITS MAY BE A MULTIPLE OF THOSE SHOWN ABOVE.
4. LEAD COLORS ARE OPTIONAL. LEADS MUST ALWAYS BE NUMBERED AS SHOWN.

REV. DESC: REVISE TO SHOW OPTIONAL COLORS			
REV. LTR: C	BY: JLP	REVISED: 01/21/99 2:28	TDR: 0171435
0810D0		FILE: AAA00005148	MDL: -
		MTL: -	

**BALDOR ELECTRIC Co.**

3PH, DV, 9 LEADS, DELTA CONNECTION

CD0180

Marketing maintained PDF of MN416:

<http://www.baldor.com/support/Literature/Load.ashx/MN416?ManNumber=MN416>