

BALDOR® • ***RELIANCE***

Product Information Packet

M1729T

25/11HP, 1760/1160RPM, 3PH, 60HZ, 324T, 1240M

Part Detail							
Revision:	P	Status:	PRD/A	Change #:		Proprietary:	No
Type:	AC	Prod. Type:	1240M	Elec. Spec:	12WGX260	CD Diagram:	CD0013
Enclosure:	TEFC	Mfg Plant:		Mech. Spec:	12C51	Layout:	12LYC051
Frame:	324T	Mounting:	F1	Poles:	04/06	Created Date:	
Base:	RG	Rotation:	R	Insulation:	F	Eff. Date:	11-24-2015
Leads:	6#10					Replaced By:	
Literature:		Elec. Diagram:					

Nameplate NP1256L										
CAT.NO.	M1729T									
SPEC.	12C051X260G1									
HP	25/11									
VOLTS	460									
AMP	30/18									
RPM	1760/1160									
FRAME	324T				HZ	60			PH	3
SER.F.	1.15		CODE	H	DES	B		CLASS	F	
NEMA-NOM-EFF			PF							
RATING	40C AMB-CONT									
CC									USABLE AT 208V	
DE	6312				ODE	6311				
ENCL	TEFC		SN							

Parts List		
Part Number	Description	Quantity
SA062947	SA 12C051X260G1	1.000 EA
RA057165	RA 12C051X260G1	1.000 EA
10CB3001	CONDUIT BOX CAST W/2.500 LEAD HOLE	1.000 EA
12GS1000SP	GASKET	1.000 EA
10XN3118K12	5/16-18 X .75 GRADE 5, ZINC PLATED	4.000 EA
HW1001A31	LOCKWASHER 5/16, ZINC PLT.591 OD, .319 I	4.000 EA
WD1000B16	T&B CX70TN TERMINAL	1.000 EA
51XF2520A08	SCREW, HEX SER SLT HD, ZN 1/4-20 X .50 L	1.000 EA
HA4051A00	PLASTIC CAP FOR GREASE FITTING	1.000 EA
10FN3001A02	310 FAN, PLASTIC 2.000 DIA. BORE	1.000 EA
HW2500A25	WOODRUFF KEY USA #1008 #BLOW CARBON STEE	1.000 EA
HA6390A01	HOSE CLAMP FOR 3.12 DIA S.S. OR PLATED	1.000 EA
HA3400A13	STUD, 1/2-13 X 7" WELKER	4.000 EA
HW1001A50	LOCKWASHER 1/2, ZINC PLT.,.879 OD, .509 I	4.000 EA
12FH1002SP	FAN COVER, CAST QF,WAUPACA QUALITY	1.000 EA
HW5100A13	W4627-047 WVY WSHER	1.000 EA
10XN3118K36	5/16-18 X 2.25" HEX HD, GRADE 5	2.000 EA
HW1001A31	LOCKWASHER 5/16, ZINC PLT.591 OD, .319 I	2.000 EA
10XN3118K40	5/16-18 X 2.50" HEX HD, GRADE 5	4.000 EA
HW1001A31	LOCKWASHER 5/16, ZINC PLT.591 OD, .319 I	4.000 EA
12EP1106A01	PU ENDPLATE, MACH 324-6T	1.000 EA
HA4051A00	PLASTIC CAP FOR GREASE FITTING	1.000 EA
10XN5013K28	1/2-13 X 1.75 HEX HEAD MACH SCREW,GRAD	4.000 EA
HW1001A50	LOCKWASHER 1/2, ZINC PLT.,.879 OD, .509 I	4.000 EA

Parts List (continued)		
Part Number	Description	Quantity
HW1001A50	LOCKWASHER 1/2, ZINC PLT.,.879 OD, .509 I	4.000 EA
XY5013A12	NUT,1/2-13,HEX,STEEL,ZINCPLATED	4.000 EA
10CB3500	CONDUIT BOX LID, CAST	1.000 EA
10GS1000SP	GASKET, CONDUIT BOX LID	1.000 EA
51XW2520A12	.25-20 X .75, TAPTITE II, HEX WSHR SLTD	4.000 EA
HW4600B41	V-RING SLINGER 2.125 X 2.880 X 0.280	1.000 EA
HW2501H33	KEY, 1/2 SQ X 3.875	1.000 EA
LB1115N	LABEL,LIFTING DEVICE (ON ROLLS)	1.000 EA
12EP1107A05	FR ENDPLATE, MACH 324-6T	1.000 EA
HW4500A21	1618BALEMITE FITTING 825 UNIVERSAL	1.000 EA
HW4500A17	317400 ALEMITE GREASE RELIEF	1.000 EA
HA4054	SHORT T-DRAIN FITTING, .125" N.P.T.	1.000 EA
MJ1000A02	GREASE, POLYREX EM EXXON (USe 4824-15A)	0.200 LB
HW4500A03	GREASE FITTING, .125 NPT 1610(ALEMITE) 8	1.000 EA
HW4500A17	317400 ALEMITE GREASE RELIEF	1.000 EA
HA4054	SHORT T-DRAIN FITTING, .125" N.P.T.	1.000 EA
MG1000G27	MED CHARCOAL METALLIC GREY 400-0096	0.080 GA
85XU0407S04	4X1/4 U DRIVE PIN STAINLESS	2.000 EA
MN416A01	TAG-INSTAL-MAINT no wire (1200/bx) 11/14	1.000 EA
LB1119N	WARNING LABEL	1.000 EA
LC0013	CONNECTION LABEL	1.000 EA
NP1256L	ALUM UL CSA CC	1.000 EA
12PA1000	PACKAGING GROUP PRINT PK1024A06	1.000 EA

Accessories		
Part Number	Description	Multiplier
12-1105	C FACE KIT	A8
12EP1501A03SP	D-FLANGE KIT	A8

AC Induction Motor Performance Data

Record # 36416 - Typical performance - not guaranteed values

Winding: 12WGX260-R002	Type: 1240M	Enclosure: TEFC
-------------------------------	--------------------	------------------------

Nameplate Data				460 V, 60 Hz: High Speed Connection	
Rated Output (HP)	25/11			Full Load Torque	74 LB-FT
Volts	460			Start Configuration	direct on line
Full Load Amps	30/18			Breakdown Torque	185 LB-FT
R.P.M.	1760/1160			Pull-up Torque	86 LB-FT
Hz	60	Phase	3	Locked-rotor Torque	115 LB-FT
NEMA Design Code	B	KVA Code	H	Starting Current	189 A
Service Factor (S.F.)	1.15			No-load Current	10.9 A
NEMA Nom. Eff.	0	Power Factor	0	Line-line Res. @ 25°C	0.597 Ω
Rating - Duty	40C AMB-CONT			Temp. Rise @ Rated Load	71°C
S.F. Amps				Temp. Rise @ S.F. Load	83°C

Load Characteristics 460 V, 60 Hz, 25 HP

% of Rated Load	25	50	75	100	125	150	S.F.
Power Factor	55	76	84	87	58	90	70
Efficiency	81.1	87.6	89.4	89.8	89.5	88	89.6
Speed	1795	1791	1785	1780	1775	1768	1777
Line amperes	13.2	17.7	23.4	30	56.7	44.3	46

Performance Graph at 460V, 60Hz, 25.0HP Typical performance - Not guaranteed values

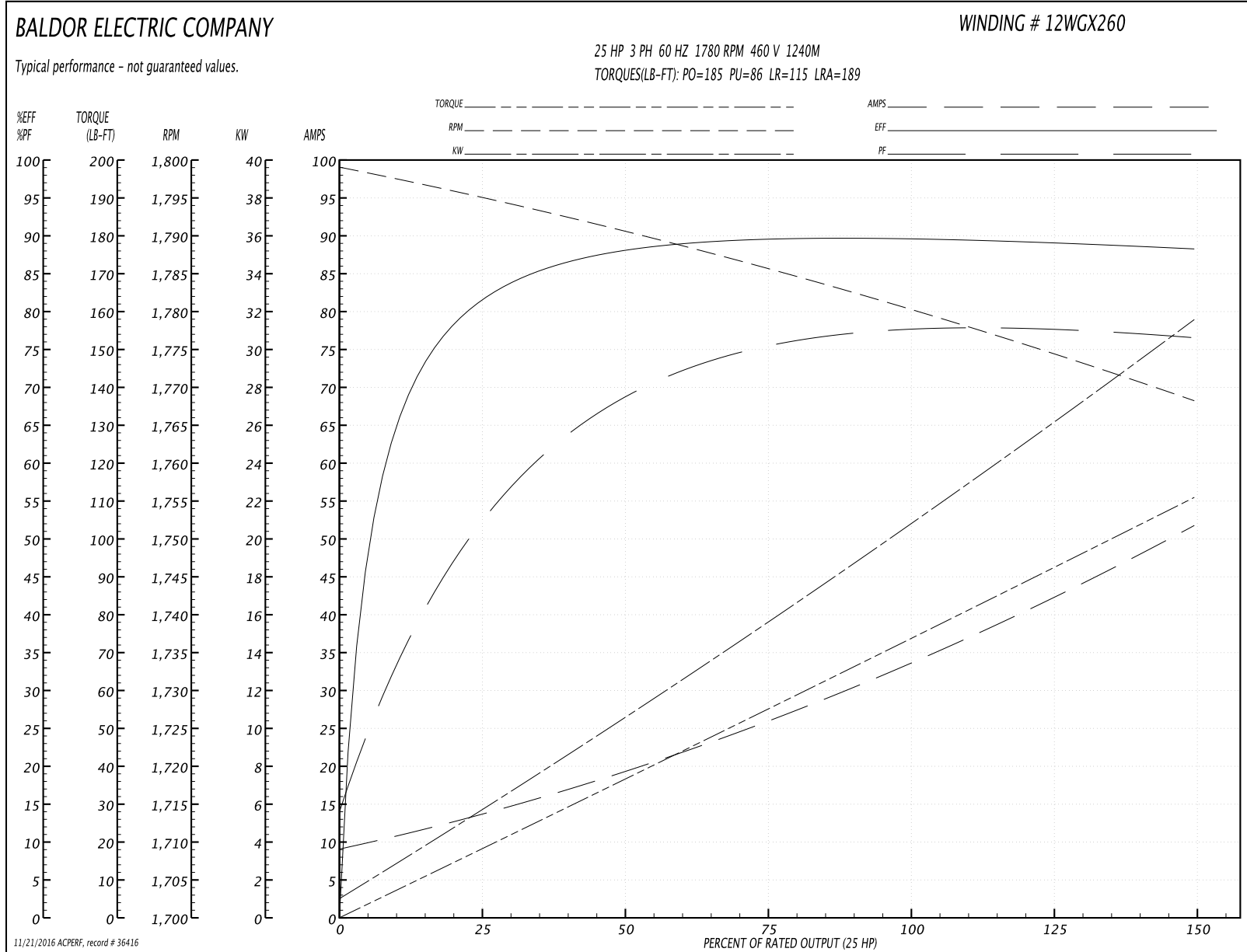

AC Induction Motor Performance Data

Record # 36417 - Typical performance - not guaranteed values

Winding: 12WGX260-R002	Type: 1240M	Enclosure: TEFC
-------------------------------	--------------------	------------------------

Nameplate Data				460 V, 60 Hz: Low Speed Connection	
Rated Output (HP)	25/11			Full Load Torque	50 LB-FT
Volts	460			Start Configuration	direct on line
Full Load Amps	30/18			Breakdown Torque	143 LB-FT
R.P.M.	1760/1160			Pull-up Torque	50 LB-FT
Hz	60	Phase	3	Locked-rotor Torque	75 LB-FT
NEMA Design Code	B	KVA Code	H	Starting Current	96 A
Service Factor (S.F.)	1.15			No-load Current	12.3 A
NEMA Nom. Eff.	0	Power Factor	0	Line-line Res. @ 25°C	0.921 Ω
Rating - Duty	40C AMB-CONT			Temp. Rise @ Rated Load	55°C
S.F. Amps				Temp. Rise @ S.F. Load	63°C

Load Characteristics 460 V, 60 Hz, 11 HP

% of Rated Load	25	50	75	100	125	150	S.F.
Power Factor	24	43	57	66	74	78	71
Efficiency	83.7	87.1	88.5	89.1	89.1	88.9	89.1
Speed	1197	1196	1193	1191	1188	1186	1189
Line amperes	13.3	14.3	15.9	18	20	23	19.2

Performance Graph at 460V, 60Hz, 11.0HP Typical performance - Not guaranteed values

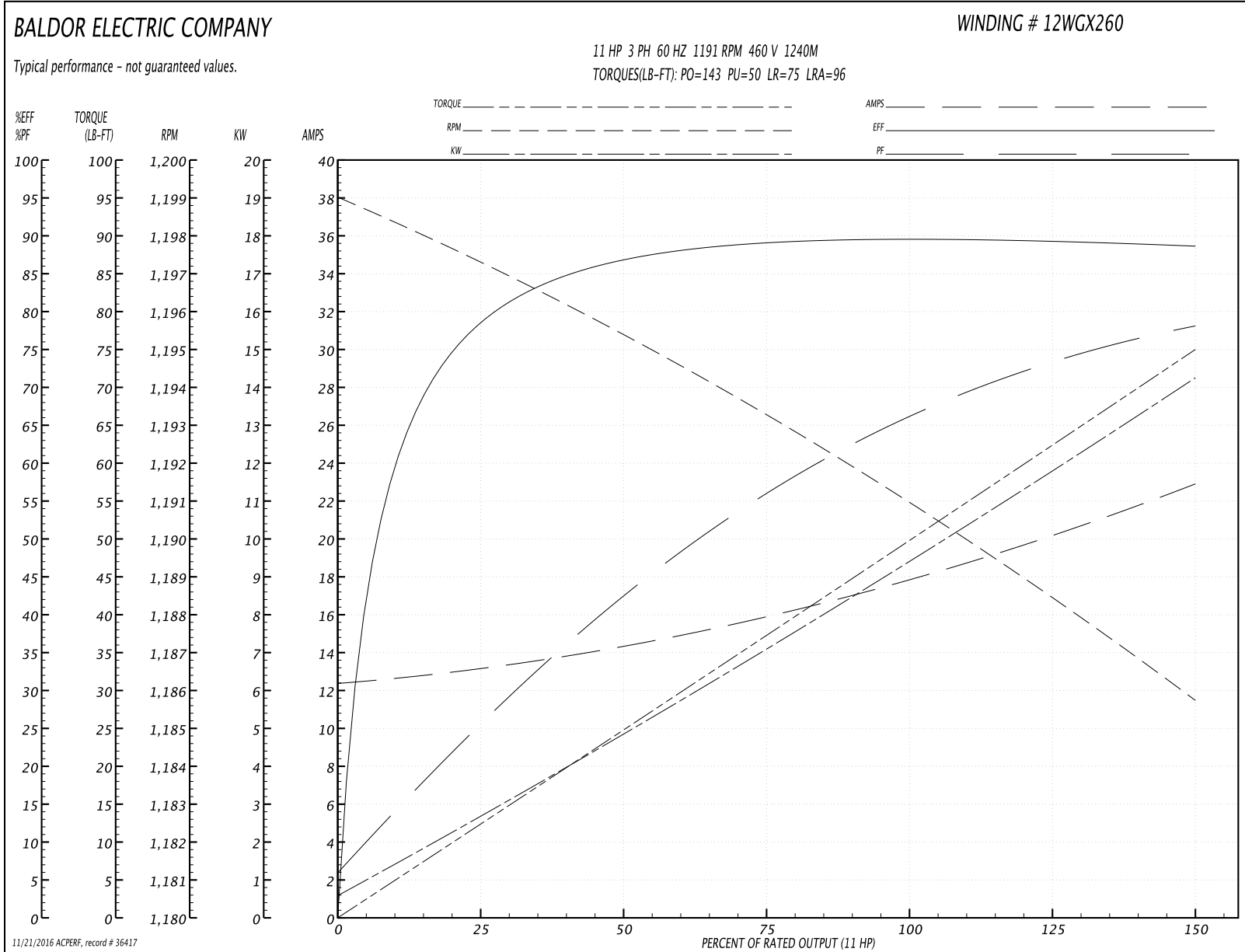

12LYC051

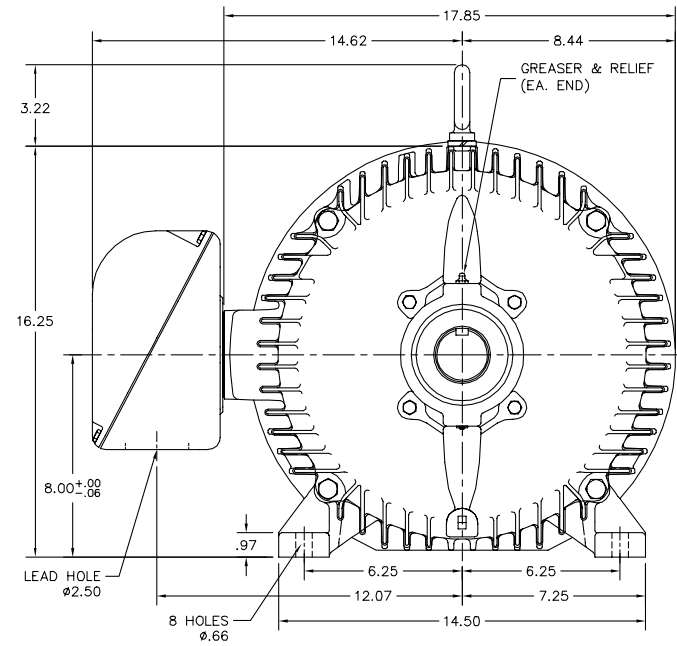
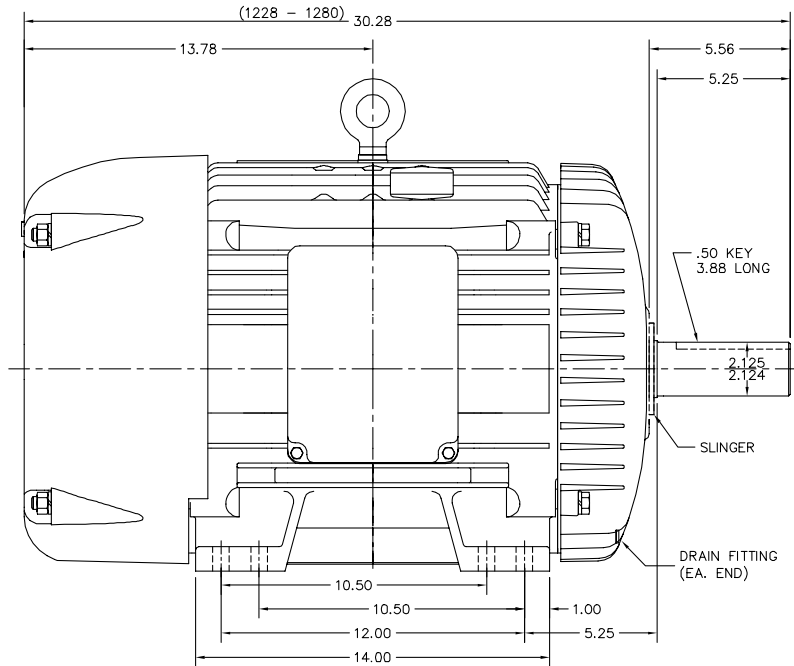

12LYC051

CUSTOMER IS RESPONSIBLE FOR DETERMINING THAT BALDOR'S PRODUCT WILL PERFORM SUITABLY IN THE INTENDED APPLICATION.

REV. DESC: ADDED FOOT THICKNESS DIM.		
REV. LTR: Y	VERSION: 08	TDR: 000000957396
FILE: \AAA\00001\609	REVISED: 11:12:13 12/17/2015	BY: ENNINDO
MTL: -		

BALDOR

HORZ TEFC 324-6T

SH 1 of 1

