

BALDOR® • RELIANCE

Product Information Packet

VEM7060T-I

30//25HP,1770//1470RPM,3PH,60//50HZ,286T

Part Detail							
Revision:	H	Status:	PRD/A	Change #:		Proprietary:	No
Type:	AC	Prod. Type:	1056M	Elec. Spec:	10WGY758	CD Diagram:	CD0005
Enclosure:	XPFC	Mfg Plant:		Mech. Spec:	10G292	Layout:	10LYG292
Frame:	286TC	Mounting:	F1	Poles:	04	Created Date:	11-22-2013
Base:	N	Rotation:	R	Insulation:	F	Eff. Date:	11-10-2016
Leads:	9#10					Replaced By:	
Literature:		Elec. Diagram:					

Nameplate NP0977XPSLEV										
NO.						CC	010A			
SER.							TEMP CODE	T3C		
SPEC.	10G292Y758G1									
CAT.NO.	VEM7060T-I									
HP	30//25 NEMA MG-1 PT.5,IP55									
VOLTS	230/460//190/380									
AMPS	72/36//74/37									
RPM	1770//1470					MOTOR WEIGHT	518			
HERTZ	60//50	PH	3	CL	F	DE BRG	6311			
SER.F.	1.15	DES	A	CODE	G	ODE BRG	6309			
FRAME	286TC		GREASE	POLYREX EM						
RATING	40C AMB-CONT									
USABLE AT 208V	76			NEMA-NOM-EFF	93.6		PF	83		
	55C AMB @ 1.0 SF,60C RISE									

Parts List		
Part Number	Description	Quantity
SA272780	SA 10G292Y758G1	1.000 EA
RA259385	RA 10G292Y758G1	1.000 EA
09FN3001C02	EXTERNAL FAN, PLASTIC	1.000 EA
12CB1003A02	CONDUIT BOX MACH. GROUP C MTRS	1.000 EA
10XN3118K24	5/16-18 X 1.50" HEX HD, GRADE 5	4.000 EA
HW1001A31	LOCKWASHER 5/16, ZINC PLT.591 OD, .319 I	4.000 EA
WD1000B19	TERMINAL BURNDY L250HP	1.000 EA
10XN3816K12	3/8-16 X 3/4 HEX HD CAP GRADE 5	1.000 EA
HW1001A38	LOCKWASHER 3/8, ZINC PLT .688 OD, .382 I	1.000 EA
HW4505A02	BREATHER/DRAIN-EXP PROOF-.250-18 PTF AIS	1.000 EA
HW3023E06	.125 X .625 SPIRAL SPRING PIN	1.000 EA
HA3050A03	3/8-16 X 2.25" GRADE 8 BOLT	4.000 EA
HW1001A38	LOCKWASHER 3/8, ZINC PLT .688 OD, .382 I	4.000 EA
HW5100A11	W3917-042 WVY WSHR (WB)	1.000 EA
10EP1710A09P	FACE MTD. EP MACH XPFC W/HW4505A02 W/PRI	1.000 EA
HW4505A02	BREATHER/DRAIN-EXP PROOF-.250-18 PTF AIS	1.000 EA
HW3023E06	.125 X .625 SPIRAL SPRING PIN	1.000 EA
HA3050A03	3/8-16 X 2.25" GRADE 8 BOLT	4.000 EA
HW1001A38	LOCKWASHER 3/8, ZINC PLT .688 OD, .382 I	4.000 EA
HA2067A01	ALUM SLINGER (AUTO)	1.000 EA
80XN1032A06	10-32 X 3/8 SET SC HEX SOCK	2.000 EA
10XN2520K40	1/4-20 X 2-1/2 HEX HD CAPSCREW, GRADE 5,Z	4.000 EA
HW1001A25	LOCKWASHER 1/4, ZINC PLT .493 OD, .255 I	4.000 EA
10FH1008A01	310 FAN HOUSING X-PROOF MACH.	1.000 EA

Parts List (continued)		
Part Number	Description	Quantity
10XN3118K12	5/16-18 X .75 GRADE 5, ZINC PLATED	3.000 EA
HW1001A38	LOCKWASHER 3/8, ZINC PLT .688 OD, .382 I	4.000 EA
XY3816A12	3/8-16 FINISHED NUT	4.000 EA
WD4100A03	DE-750 HEYCO PLUG 62MP0750 MICRO PLASTIC	1.000 EA
12CB1502A01	CONDUIT BOX LID MACH. GROUP C MTRS	1.000 EA
84XN5013J32	SOCKET HD.CAP SCR,1/2-13 X 2"LG,ALLOY ST	10.000 EA
HW1001A50	LOCKWASHER 1/2, ZINC PLT.,.879 OD, .509 I	10.000 EA
HW2501H28	KEY, 1/2 SQ X 3.250	1.000 EA
LB1115N	LABEL,LIFTING DEVICE (ON ROLLS)	1.000 EA
LB1081C	ALUM XP CAUTION LABEL (COL PLANT ONLY-	1.000 EA
MN416A01	TAG-INSTAL-MAINT no wire (1200/bx) 11/14	1.000 EA
PK6014	STEEL STRAP FOR 309-312 BASELESS MOTORS	3.000 EA
10XN3816K10	BOLT, 3/8-16 X 5/8 HHCS YZ	3.000 EA
10EP1701A25P	FR ENDPLATE, MACH W/PRIMER	1.000 EA
HW4500A20	1/8NPT SL PIPE PLUG	2.000 EA
MJ1000A02	GREASE, POLYREX EM EXXON (USe 4824-15A)	0.130 LB
HW4500A20	1/8NPT SL PIPE PLUG	2.000 EA
HW2500A25	WOODRUFF KEY USA #1008 #BLOW CARBON STEE	1.000 EA
51XB1214A20	12-14X1.25 HXWSSLD SERTYB	1.000 EA
MG1025G05	WILKOFASST, 789.227, MED. GRAY CHAR. MET.	0.070 GA
85XU0407S04	4X1/4 U DRIVE PIN STAINLESS	6.000 EA
LB1119N	WARNING LABEL	1.000 EA
LC0145B01	CONNECTION LABEL	1.000 EA
NP0977XPSLEV	SS XP UL CSA-EEV CC CL-I GP-C&D	1.000 EA

10PA1051	PKGP CRATE 310 VERT 32X30-1/2X17-1/2 RIS	1.000 EA
----------	--	----------

AC Induction Motor Performance Data

Record # 53263 - Typical performance - not guaranteed values

Winding: 10WGY758-R018	Type: 1056M	Enclosure: XPFC
-------------------------------	--------------------	------------------------

Nameplate Data				460 V, 60 Hz: High Voltage Connection	
Rated Output (HP)	30//25			Full Load Torque	89.1 LB-FT
Volts	230/460//190/380			Start Configuration	direct on line
Full Load Amps	72/36//74/37			Breakdown Torque	270 LB-FT
R.P.M.	1770//1470			Pull-up Torque	128 LB-FT
Hz	60//50	Phase	3	Locked-rotor Torque	145 LB-FT
NEMA Design Code	B	KVA Code	G	Starting Current	235 A
Service Factor (S.F.)	1.15			No-load Current	15.9 A
NEMA Nom. Eff.	93.6	Power Factor	83	Line-line Res. @ 25°C	0.226 Ω
Rating - Duty	40C AMB-CONT			Temp. Rise @ Rated Load	57°C
S.F. Amps				Temp. Rise @ S.F. Load	71°C
				Locked-rotor Power Factor	32
				Rotor inertia	4.45 LB-FT ²

Load Characteristics 460 V, 60 Hz, 30 HP

% of Rated Load	25	50	75	100	125	150	S.F.
Power Factor	44	66	75	83	83	83	83
Efficiency	90.6	93.7	94.3	94	93.2	93	93.5
Speed	1794	1787	1781	1774	1766	1757	1769
Line amperes	17.9	23	30.1	36.2	45.3	54.5	41.7

Performance Graph at 460V, 60Hz, 30.0HP Typical performance - Not guaranteed values

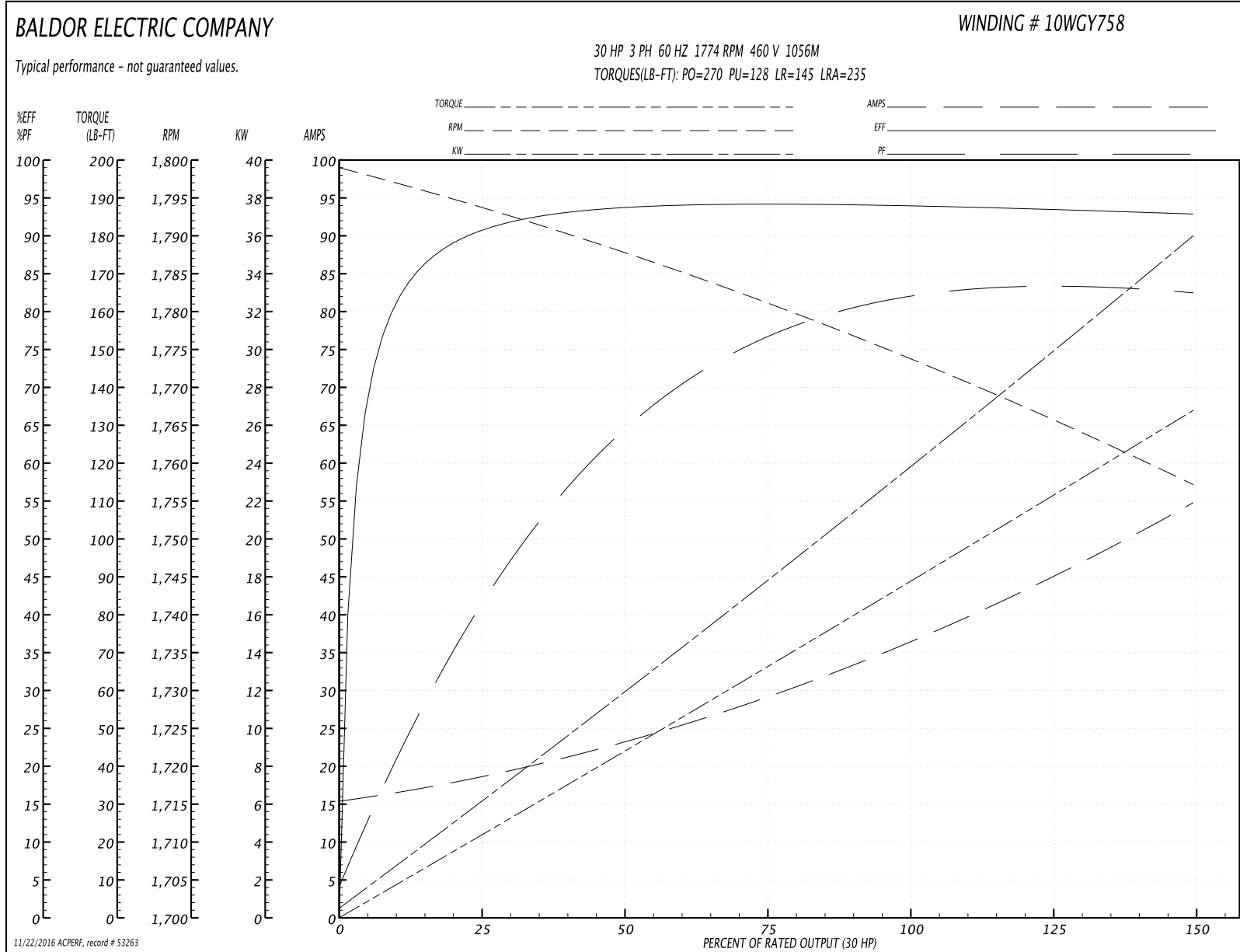

AC Induction Motor Performance Data

Record # 53264 - Typical performance - not guaranteed values

Winding: 10WGY758-R018	Type: 1056M	Enclosure: XPFC
-------------------------------	--------------------	------------------------

Nameplate Data				380 V, 50 Hz: High Voltage Connection	
Rated Output (HP)	30//25			Full Load Torque	89.3 LB-FT
Volts	230/460//190/380			Start Configuration	direct on line
Full Load Amps	72/36//74/37			Breakdown Torque	267 LB-FT
R.P.M.	1770//1470			Pull-up Torque	131 LB-FT
Hz	60//50	Phase	3	Locked-rotor Torque	149 LB-FT
NEMA Design Code	B	KVA Code	G	Starting Current	224 A
Service Factor (S.F.)	1.15			No-load Current	15.5 A
NEMA Nom. Eff.	93.6	Power Factor	83	Line-line Res. @ 25°C	0.226 Ω
Rating - Duty	40C AMB-CONT			Temp. Rise @ Rated Load	57°C
S.F. Amps				Temp. Rise @ S.F. Load	75°C
				Locked-rotor Power Factor	35
				Rotor inertia	4.45 LB-FT ²

Load Characteristics 380 V, 50 Hz, 25 HP

% of Rated Load	25	50	75	100	125	150	S.F.
Power Factor	45	67	76	83	83	83	83
Efficiency	90	93.2	93.7	93.4	91.9	92	92.5
Speed	1494	1487	1481	1474	1466	1457	1469
Line amperes	17.6	22.9	30.2	36.5	45.9	55.5	42.1

Performance Graph at 380V, 50Hz, 25.0HP Typical performance - Not guaranteed values

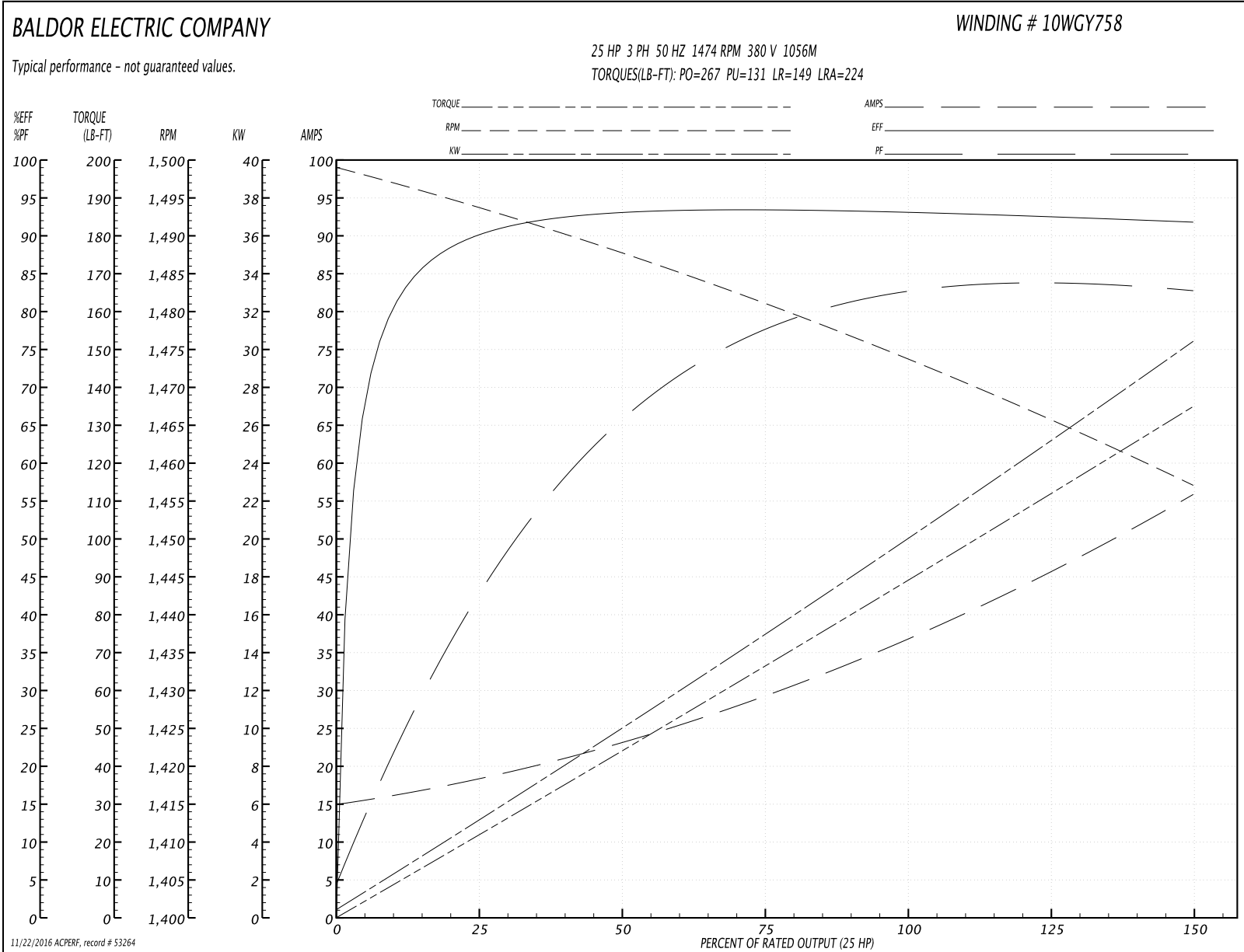

10LYG292

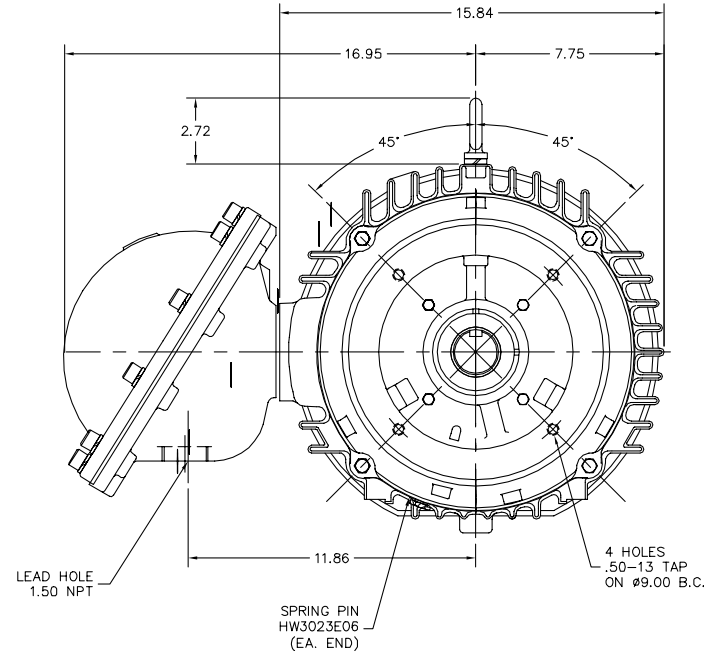
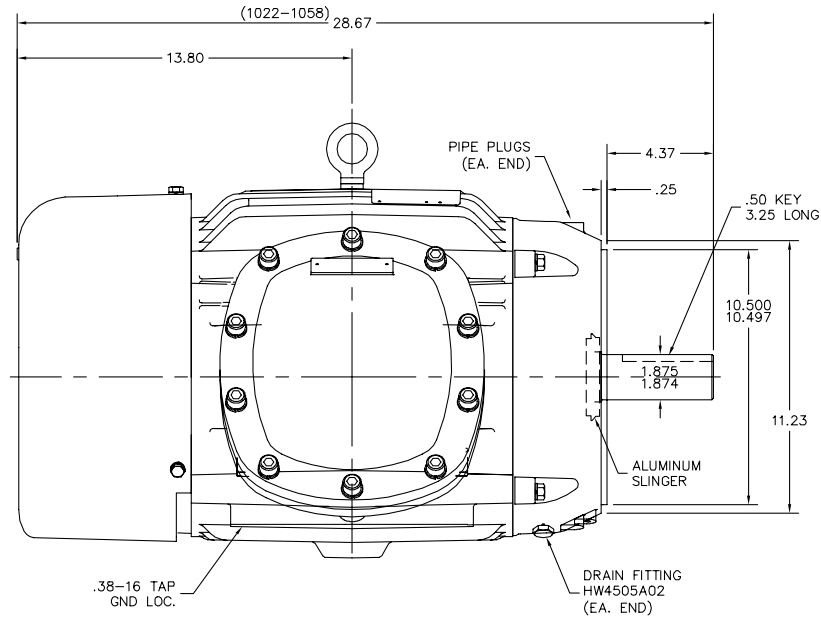

10LYG292

CUSTOMER IS RESPONSIBLE FOR DETERMINING THAT BALDOR'S PRODUCT WILL PERFORM SUITABLY IN THE INTENDED APPLICATION.

REV. DESC: ADDED GND HOLE TAP SIZE	VERSION: 05	TDR: 000000954909
REV. LTR: E	REVISED: 03:14:34 12/07/2015	BY: ENNINDO
FILE: \AAA\00137\778		
MTL: -		

BALDOR

VERT XPFC 284-6TC CL.I GP.C&D ONLY DRILL RIG
SH 1 of 1

CD0005



LOW VOLTAGE
(2Y)

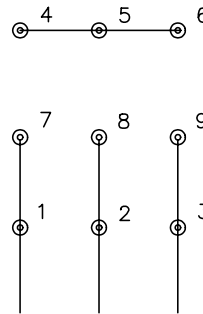

LINE

HIGH VOLTAGE
(1Y)

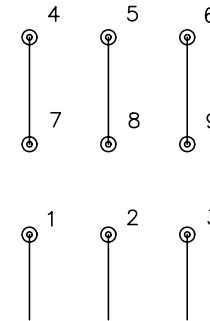

LINE

NOTES:

1. INTERCHANGE ANY TWO LINE LEADS TO REVERSE ROTATION.
2. OPTIONAL THERMOSTATS ARE PROVIDED WHEN SPECIFIED.
3. ACTUAL NUMBER OF INTERNAL PARALLEL CIRCUITS MAY BE A MULTIPLE OF THOSE SHOWN ABOVE.
4. LEAD COLORS ARE OPTIONAL. LEADS MUST ALWAYS BE NUMBERED AS SHOWN.

REV. DESC: REVISE TO SHOW OPTIONAL COLORS

REV. LTR: E BY: JLP

REVISED: 01/19/99 10:15

TDR: 0171435

9000D

FILE: AAA00005140

MDL: -

MTL: -

BALDOR ELECTRIC Co.

3PH, DV, 9 LEADS

CD0005