

SP/SPE

Stainless steel submersible pumps

Installation and operating instructions



SP/SPE

English (US)

Installation and operating instructions 4

Français (CA)

Notice d'installation et de fonctionnement. 48

Español (MX)

Instrucciones de instalación y operación 94

Appendix A. 140

Original installation and operating instructions

Table of contents

1.	Limited warranty	4
2.	General information	5
2.1	Hazard statements	5
2.2	Notes	5
3.	Product description	6
3.1	Product introduction	6
3.2	Applications	6
3.3	Drinking water	6
3.4	Features and benefits	6
3.5	Type key	7
4.	Delivery, handling and storage	8
4.1	Scope of delivery	8
4.2	Handling	8
4.3	Storage	8
5.	Operating conditions	8
6.	Installation	9
6.1	Pre-installation checklist	9
6.2	Positional requirements	10
6.3	Preparation	11
6.4	Removing and fitting the cable guard	13
6.5	Splicing the motor cable	13
6.6	Riser pipe	14
6.7	Electrical and variable-frequency drive information	16
7.	Startup	22
7.1	Startup with three-phase motors	22
8.	Operating the product	24
8.1	Minimum flow rate	24
8.2	Soft starter	25
8.3	Maintenance and service	25
9.	Troubleshooting	26
9.1	SPE	26
9.2	Preliminary tests	27
9.3	Checking pump performance	28
9.4	Troubleshooting the product	28
10.	Technical data	30
10.1	Motor cooling requirements	30
10.2	Guide for engine-driven generators in submersible pump applications	31
10.3	Transformer capacity required for three-phase submersible motors	32
10.4	Submersible drop cable selection charts (60 Hz)	32
10.5	Approvals	40
10.6	Electrical data	41
11.	Disposing of the product	47

1. Limited warranty

Products manufactured by GRUNDFOS PUMPS CORPORATION (Grundfos) are warranted to the original user only to be free of defects in material and workmanship for a period of 24 months from date of installation, but not more than 30 months from date of manufacture. Grundfos' liability under this warranty shall be limited to repairing or replacing at Grundfos' option, without charge, FOB Grundfos' factory or authorized service station, any product of Grundfos' manufacture. Grundfos will not be liable for any costs of removal, installation, transportation, or any other charges which may arise in connection with a warranty claim. Products which are sold but not manufactured by Grundfos are subject to the warranty provided by the manufacturer of said products and not by Grundfos' warranty. Grundfos will not be liable for damage or wear to products caused by abnormal operating conditions, accident, abuse, misuse, unauthorized alteration or repair, or if the product was not installed in accordance with Grundfos' printed installation and operating instructions.

To obtain service under this warranty, the defective product must be returned to the distributor or dealer of Grundfos' products from which it was purchased together with proof of purchase and installation date, failure date, and supporting installation data. Unless otherwise provided, the distributor or dealer will contact Grundfos or an authorized service station for instructions. Any defective product to be returned to Grundfos or a service station must be sent freight prepaid; documentation supporting the warranty claim and/or a Return Material Authorization must be included if so instructed.

GRUNDFOS WILL NOT BE LIABLE FOR ANY INCIDENTAL OR CONSEQUENTIAL DAMAGES, LOSSES, OR EXPENSES ARISING FROM INSTALLATION, USE, OR ANY OTHER CAUSES. THERE ARE NO EXPRESS OR IMPLIED WARRANTIES, INCLUDING MERCHANTABILITY OR FITNESS FOR A PARTICULAR PURPOSE, WHICH EXTEND BEYOND THOSE WARRANTIES DESCRIBED OR REFERRED TO ABOVE.

Some jurisdictions do not allow the exclusion or limitation of incidental or consequential damages and some jurisdictions do not allow limit actions on how long implied warranties may last. Therefore, the above limitations or exclusions may not apply to you. This warranty gives you specific legal rights and you may also have other rights which vary from jurisdiction to jurisdiction.

2. General information



Read this document before you install the product. Installation and operation must comply with local regulations and accepted codes of good practice.

The use of this product requires experience with and knowledge of the product.



Persons with reduced physical, sensory or mental capabilities must not use this product, unless they are under supervision or have been instructed in the use of the product by a person responsible for their safety.

Children must not use or play with this product.



A red or grey circle with a diagonal bar, possibly with a black graphical symbol, indicates that an action must not be taken or must be stopped.



If these instructions are not observed, it may result in malfunction or damage to the equipment.



Tips and advice that make the work easier.

2.1 Hazard statements

The symbols and hazard statements below may appear in Grundfos installation and operating instructions, safety instructions and service instructions.



DANGER

Indicates a hazardous situation which, if not avoided, will result in death or serious personal injury.



WARNING

Indicates a hazardous situation which, if not avoided, could result in death or serious personal injury.



CAUTION

Indicates a hazardous situation which, if not avoided, could result in minor or moderate personal injury.

The hazard statements are structured in the following way:



SIGNAL WORD

Description of the hazard

Consequence of ignoring the warning

- Action to avoid the hazard.

2.2 Notes

The symbols and notes below may appear in Grundfos installation and operating instructions, safety instructions and service instructions.



Observe these instructions for explosion-proof products.



A blue or grey circle with a white graphical symbol indicates that an action must be taken.

3. Product description

3.1 Product introduction

This manual includes instructions for installation, operation, and maintenance of Grundfos SP submersible pumps with 0.5 to 250 Hp motors.

3.2 Applications

Grundfos SP submersible pumps are suitable for the following applications:

- groundwater supply to waterworks
- irrigation in horticulture and agriculture
- groundwater lowering (dewatering)
- pressure boosting
- industrial applications
- domestic water supply.

The pump must be installed so that the suction interconnector is completely submerged in the liquid. The pump can be installed horizontally or vertically. See section Positional requirements.

3.2.1 Pumped liquids

The pumps are designed for pumping clean, thin, non-explosive liquids without solid particles or fibers.

The maximum sand content of the water must not exceed 50/100/150 ppm. A larger sand content may reduce the life of the pump and increase the risk of blockage.

Pump type	Maximum content of sand [ppm]
SP 5S - SP 25S	50
SP 35S - SP 77S	150
SP 85S - SP 300S	100
SP 385S - SP 1100S	50



When pumping liquids with a density higher than water ($62.3 - 62.4 \text{ lb/ft}^3$), motors with correspondingly higher outputs must be used.

If liquids with a viscosity higher than water are to be pumped, contact Grundfos.

N AISI 416 and R AISI 904L grade stainless steel pump sets are designed for liquids more aggressive than drinking water.

For the maximum liquid temperature, see section Motor cooling requirements.

Related information

[10.1.1 Maximum water temperature - minimum velocity/flow past the motor](#)

3.3 Drinking water

If the product is used for drinking water, the following precautions must be taken to avoid contamination:

- Before use, make sure that the product does not come into contact with dust or with chemicals not suitable for contact with drinking water, for example lubricants, greases or oils.
- If the pump is used with potentially toxic liquids, it can no longer be used for drinking water.
- Always use original parts to maintain the initial hygienic characteristics of the product.

3.4 Features and benefits

- state-of-the-art hydraulics provide high efficiency and low operating costs
- 100 % stainless steel components inside and outside for long service life
- resistant to sand
- resistant to aggressive water
- monitoring, protection, and communication through protection unit MP 204, and GO remote control.

3.5 Type key

Example	SPE	475	S	500	5	PD
Pos.	1	2	3	4	5	6

Pos.	Description
1	Pump type
	- or SP = Standard design
	SPE = ECM-design (MS6000P)
2	Rated flow rate in gpm
3	Material version
	Stainless steel parts of material
	S = AISI 304 (EN 1.4301) SS
	N = AISI 316 (EN 1.4401) SS
	R = AISI 904L (EN 1.4539) SS
4	Hp of motor
5	Number of impellers
	BP = Bare Pump
6	- = Pump and motor (Standard or ECM motor)
	CUE - Standard motor and VFD
	PD - ECM motor and VFD (SPE only)

4. Delivery, handling and storage

4.1 Scope of delivery

Make sure that the pump and its components, motor, cable, or control box are not damaged during transportation.

4.2 Handling

WARNING

Crushing of feet

Death or serious personal injury

- Stack the pumps with the biggest at the bottom, and do not stack above 1 m.
- Use lifting equipment which is approved for the weight of the product.
- Wear personal protective equipment.



WARNING

Crushing of hands

Death or serious personal injury

- Stack the pumps with the biggest at the bottom, and do not stack above 1 m.
- Use lifting equipment which is approved for the weight of the product.



Store the pump in the package until it is ready for installation.

Handle the pump with care.



Fix the extra nameplate supplied with the pump at the installation site.

Do not expose the pump to mechanical impact, vibrations etc.

4.3 Storage

4.3.1 Storage temperature

Pump: -4 to +140 °F (-20 to +60 °C).

Motor: -4 to +158 °F (-20 to +70 °C).

Store the motors in a closed, dry and well ventilated room.



If MMS motors are stored, the shaft must be turned by hand at least once a month. If a motor has been stored for more than a year before installation, the rotating parts of the motor must be dismantled and checked before use.

Do not expose the pump to direct sunlight.

If the pump is unpacked, store it horizontally, or vertically to prevent misalignment. Make sure that the pump cannot roll or fall over. Support it if necessary.

During storage, the pump can be supported as indicated in the figure below.

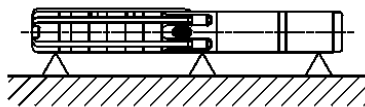

TMM001349

Pump position during storage

4.3.2 Frost protection

If the pump has to be stored after use, it must be stored on a frost-free location, or the motor liquid must be frost-proof.

5. Operating conditions

Flow rate, Q:	Up to 1400 gpm (318 m ³ /h)
Head, H:	Up to 2657 ft (810 m)
Liquid temperature:	32-140 °F (0-60 °C)
	MS 402 492 ft (150 m) (213 psi)
	MS 4000 1969 ft (600 m) (852 psi)
Maximum submersible depth:	MS 6000 1969 ft (600 m) (852 psi)
	All MMS 1969 ft (600 m) (852 psi)

6. Installation

DANGER

Electric shock

- Death or serious personal injury
- Switch off the power supply before you start any work on the product.
- Make sure that the power supply cannot be switched on accidentally.



WARNING

Crushing of feet

- Death or serious personal injury
- When lifting the pump out of the box, use lifting equipment which is approved for the weight of the product.
- Wear personal protective equipment.



WARNING

Crushing of hands

- Death or serious personal injury
- When lifting the pump out of the box, use lifting equipment which is approved for the weight of the product.
- Wear personal protective equipment.



Install products in accordance with local regulations. Installation must be carried out by a qualified person.



Use a sine-wave filter when operating an SPE pump set.



Fit a 12 inch long pipe to the pump to during installation.

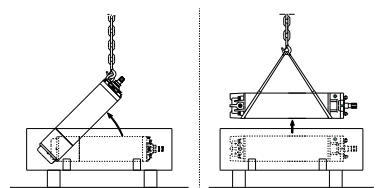

TM059648

Handling of the motor

6.1 Pre-installation checklist

Check the following before installation:

- condition of the well
- condition of the water
- installation depth
- power supply
- cable type.

These checks are all critical for the proper installation of this pump.

6.1.1 Condition of the well

If the pump is to be installed in a new well, make sure that the well is fully developed and bailed or blown free of cuttings, drillings and sand. The stainless steel construction makes the pump resistant to abrasion. However; constant exposure to sandy water may cause damage to the pump.

If this pump is used to replace an oil-filled submersible or oil-lubricated line-shaft turbine pump in an existing well, the well must be blown or bailed clear of oil.

Determine the maximum depth of the well, and the draw-down level at the maximum capacity of the pump. Use this data for pump selection and to determine installation depth.

Check the inside diameter of the well casing to ensure that it is larger than the size of the pump and motor.

6.2 Positional requirements

WARNING

Crushing of hands

Death or serious personal injury

- If the pump is to be installed in a position where it is accessible, make sure the coupling is isolated and cannot be touched. For instance, the pump can be built into a flow sleeve.



Depending on the motor type, the pump can be installed either vertically or horizontally. A complete list of motor types suitable for horizontal installation is shown in section Motors suitable for horizontal installation. If the pump is installed horizontally, the outlet port must never fall below the horizontal plane. See the figure below.

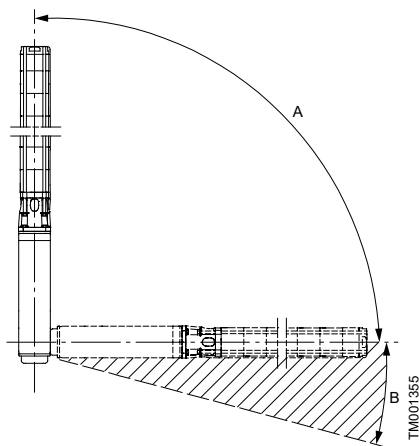

Positional requirements

Pos.	Description
A	Allowed
B	Not allowed

If the pump is installed horizontally, fit it in a flow sleeve.

Related information

[3.2 Applications](#)

[6.2.1 Motors suitable for horizontal installation](#)

6.2.1 Motors suitable for horizontal installation

Motor	Output power	Output power
	60 Hz	50 Hz
	[Hp (kW)]	[Hp (kW)]
MS	0.5 - 40 (0.37 - 30)	All
MMS6	50-60 (37 - 44.7)	5-50 (3.7 - 37)
MMS8000	30-150 (22-112)	30-150 (22-112)
MMS10000	100-250 (75-190)	100-250 (75-190)

CAUTION

Hot surface

Minor or moderate personal injury



- If the pump is used to transfer hot (104-140 °F) liquid, make sure it cannot be touched, by adding extra covers or guard rails on the pump or around the installation spot.



During operation, the suction interconnector of the pump must always be completely submerged in the liquid. Make sure that the NPSH values are fulfilled.

6.2.2 Pumped liquids



This pump is tested for use with water only. Water temperature should not exceed rated motor temperature. SP pumps can withstand water temperatures up to 140 °F (60 °C). Water temperature exceeding the rated temperature shortens the lifespan of the motor. Using the pump with different liquids than water is a customer responsibility. For drinking water applications, the temperature must not exceed 86 °F (30 °C).

Submersible pumps are designed for pumping the following liquids:

- clear and cold water that is free of air and gasses
- clean, thin, non-explosive liquids without solid particles or fibers.

Decreased pump performance and life expectancy can occur if the water is not cold and clear or contains air and gasses.

See the flow velocity table in section Motor cooling requirements.

Flow rate, Q: 0.44 - 1475 gpm (0.1 - 335 m³/h)

Head, H: Maximum 2657 ft (810 m)

When the pump is used for pumping water above the rated temperatures of the motor, pay attention to the minimum water flow past the motor for cooling. Water temperature that exceeds the rated temperature shortens the lifespan of the motor.

The pump is highly resistant to the normal corrosive environment found in some water wells. If water well tests show that the water has an excessive or unusual corrosive quality, or exceeds the motor temperature rating, contact Grundfos.

6.3 Preparation

DANGER

Electric shock

Death or serious personal injury



- Switch off the power supply before you start any work on the product.
- Make sure that the power supply cannot be switched on accidentally.

6.3.1 Checking the motor liquid

The MS submersible motors are factory-filled with SML-3 liquid, which is frost-proof down to -4 °F (-20 °C).



Check the level of the motor liquid and refill if required. Use tap water.



If frost protection is required, special Grundfos liquid must be used to refill the motor. Otherwise tap water may be used for refilling.

Refill the liquid as described below.

6.3.2 Grundfos submersible motors MS4000 and MS402

The filling hole for the motor liquid is placed in the following positions:

MS4000: on the side of the motor near the top.

MS402: on the bottom of the motor.

1. Position the pump as indicated in the figure below. Make sure that the filling screw is at the highest point of the motor.
2. Remove the screw from the filling hole.
3. Inject liquid into the motor with the filling syringe as indicated in the figure below until the liquid runs back out of the filling hole.
4. Replace the screw in the filling hole and tighten securely before changing the position of the pump.

Torques:

MS4000: 2.2 ft-lbs (3.0 Nm).

MS402: 1.5 ft-lbs (2.0 Nm).

The pump is now ready for installation.

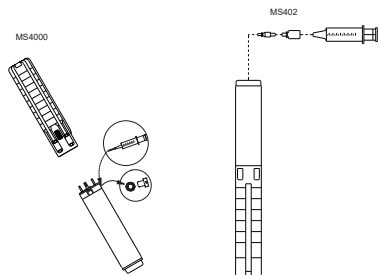

Pump position during filling, MS4000 and MS402

6.3.3 Grundfos submersible motors, MS6000 and MS6000P

- If the motor is delivered from stock, the liquid level must be checked before the motor is fitted to the pump. See the figure below.
- On pumps delivered directly from Grundfos, the liquid level has already been checked.
- In case of service, the liquid level must be checked. See the figure below.

Filling procedure:

The filling hole for the motor liquid is placed on the top of the motor.

1. Position the pump as indicated in the figure below. Make sure that the filling screw is at the highest point of the motor.
2. Remove the screw from the filling hole.
3. Inject liquid into the motor with the filling syringe (see the figure below) until the liquid runs back out of the filling hole.
4. Replace the screw in the filling hole and tighten securely before changing the position of the motor.

Torque: 2.2 ft-lbs (3.0 Nm).

The pump is now ready for installation.

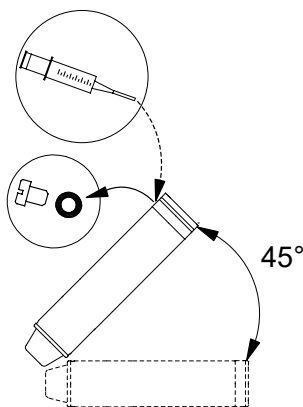

Motor position during filling, MS6000 and MS6000P

6.3.4 Grundfos submersible motors, MMS6, MMS8000 and MMS10000

Filling procedure:

1. Place the motor at a 45 ° angle with the top of the motor upwards. See the figure below.
2. Unscrew the plug A and place a funnel in the hole.
3. Pour tap water into the motor until the motor liquid inside the motor starts running back out of the filling hole.



Do not use motor liquid that contains oil.

4. Remove the funnel and refit the plug A.



Before fitting the motor to a pump after a long period of storage, lubricate the shaft seal by adding a few drops of water and turning the shaft.

The pump is now ready for installation.

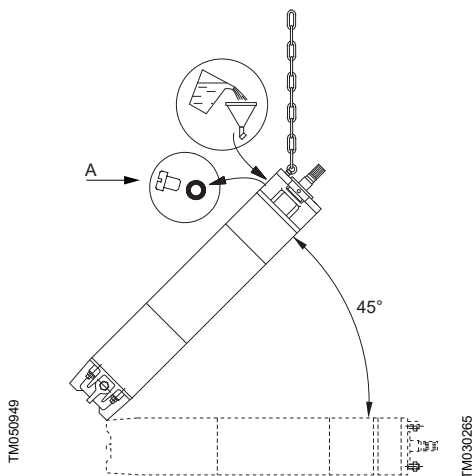

Motor position during filling, MMS

Pos.	Description
A	Plug

6.3.5 Installation depth

Make sure that the installation depth of the pump is always at least 3 ft (1 m) below the maximum draw-down level of the well. For flow rates exceeding 100 gpm (22.7 m³/h), refer to the performance curves for recommended minimum submergence.

Never install the pump so that the bottom of the motor is lower than the top of the well screen or within 5 ft (1.5 m) of the well bottom.

If the pump is to be installed in a lake, pond, tank or large diameter well, make sure that the water velocity passing over the motor is sufficient to ensure proper motor cooling. The minimum recommended water flow rates ensuring proper cooling are listed in section Maximum water temperature.

Related information

[10.1.1 Maximum water temperature - minimum velocity/flow past the motor](#)

6.3.6 Power supply

Check the motor voltage, phase number and frequency indicated on the motor nameplate against the actual power supply.

6.3.7 Power cable type

The power cable used between the pump and the control box or control panel must be approved for submersible pump applications. Conductors may be solid or stranded. The cable may consist of individually insulated conductors twisted together, insulated conductors molded side by side in one flat cable or insulated conductors with a round overall jacket.

The conductor insulation must be type RW, RUW, TW, TWU or equivalent and must be suitable for use with submersible pumps. An equivalent Canadian Standards Association (CSA) certified cable may also be used.

Related information

[10.4 Submersible drop cable selection charts \(60 Hz\)](#)

6.4 Removing and fitting the cable guard

If the cable guard is attached with screws, remove the screws to loosen it. To fit the cable guard on the pump, tighten the screws to fit it securely to the pump. See Appendix A for further details.



Make sure that the pump chambers are aligned when the cable guard has been fitted.

6.5 Splicing the motor cable



A good cable splice is critical to proper operation of the pump.

If the splice is carefully made, it works as well as any other portion of the cable, and is completely watertight. Use a heat shrink splice kit. Make the splice in accordance with the kit manufacturer's instructions. Typically a heat shrink splice can be made as follows:

1. Check the motor - and the submersible drop cables for damage.
2. Cut the motor leads off in a staggered manner. Cut the ends of the drop cable so that the ends match up with the motor leads. See the figure Cutting and stripping the motor leads below. On single-phase motors, make sure to match the colors.
3. Strip back and trim off 1/2 inch of insulation from each lead, making sure to scrape the wire bare to obtain a good connection. Be careful not to damage the copper conductor when stripping off the insulation.
4. Slide the heat shrink tubing on to each lead. Insert a properly sized "Sta-Kon" type connector on each lead, making sure that lead colors are matched. Using "Sta-Kon" crimping pliers, indent the lugs. See the figure Crimping the connectors below. Make sure to squeeze hard on the pliers, particularly in the case of a large cable.
5. Center the heat shrink tubing over the connector. Using a propane torch, lighter, or electric heat gun, uniformly heat the tubing starting first in the center working towards the ends. See the figure Applying heat to the connector below.
6. Continue to apply the heat to the tubing. Make sure not to let the flame directly contact the tubing. When the tubing shrinks and the sealant flows from the ends of the tubing, the splice is complete. See the figure Completed splices below.

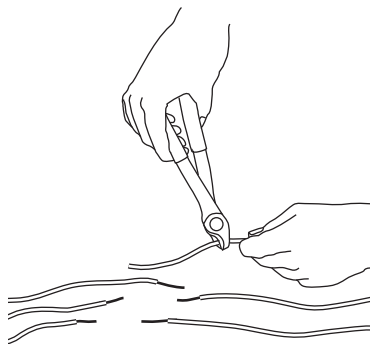

TM050032_0611

Cutting and stripping the motor leads

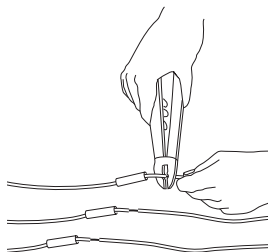

TM050033_0611

Crimping the connectors

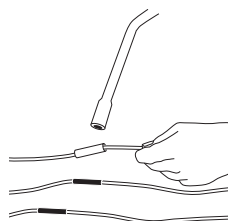

TM050034_0611

Applying heat to the connector

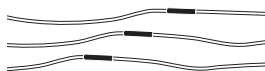

TM050035_0611

Completed splices

6.6 Riser pipe

WARNING

Sharp element

Death or serious personal injury



- When mounting the riser pipe, adapter or hose, wear personal protective equipment to avoid cutting on sharp edges on the pump.



Make sure that the riser pipe or hose are properly sized and selected based on the estimated flow rates and friction-loss factors.

6.6.1 If an adapter is required

Install the riser pipe to the pipe adapter. Then install the riser pipe with the adapter to the pump outlet port.

Use a back-up wrench when attaching the riser pipe to the pump. Make sure that the pump is gripped only by the flats on the top of the outlet chamber. The body of the pump, cable guard or motor must not be gripped under any circumstances.

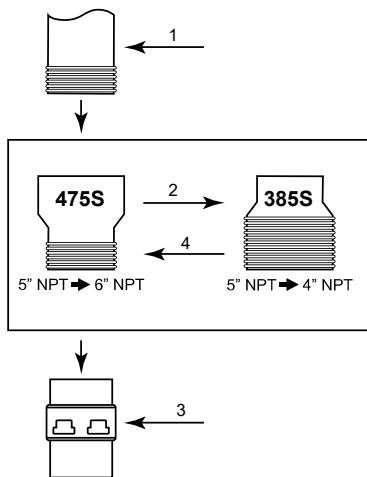

Pipe adapters

Pos.	Description
1	Riser pipe
2	Pipe adapters
3	Pump outlet
4	or

TM050036

6.6.2 If a steel riser pipe is used

Always use steel riser pipes with the large submersible pumps. Use an approved pipe thread compound on all joints. Make sure the joints are adequately tightened to prevent the joints from coming loose when the motor starts and stops.

When tightened, make sure that the first section of the riser pipe does not come in contact with the check valve retainer.

After the first section of the riser pipe is attached to the pump, clamp the lifting wire to the pump, if there is a provision on the pump for a lifting wire. If not, clamp the lifting wire to the first section of the riser pipe.

When raising the pump and riser pipe section to vertical position, make sure not to place bending stress on the pump by picking it up at the pump end only.

Make sure that the power cables are not cut or damaged when the pump is being lowered in the well.

Fasten the submersible drop cable to the riser pipe at frequent intervals to prevent sagging, looping or possible cable damage. Nylon cable clips or waterproof tape may be used. Protect the cable splice by securing it with clips or tape just above and below the splice.

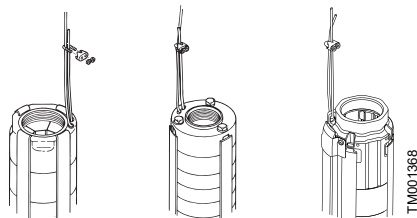

Fixing the straining wire

6.6.3 If a plastic or flexible riser pipe is used



Use plastic riser pipes only with the smaller domestic submersible pumps.

Important: Plastic and flexible pipes tend to stretch under load. Take this stretching into account when securing the cable to the riser pipe. Leave 3 to 4 inches (75 to 100 mm) of slack between clips or taped points to allow for this stretching. This tendency for plastic and flexible pipe to stretch also affects the calculation of the pump installation depth. As a general rule, plastic pipe stretches to approximately 2 % of its length. For example, if a 200 feet (61 m) of plastic riser pipe is installed, the pump may actually be down 204 feet (62 m). If the installation depth is critical, check with the manufacturer of the pipe to determine how to compensate for pipe stretch.



When a plastic riser pipe is used, attach a safety cable to the pump to lower and raise it.

When plastic pipes are used, secure the pump by an unloaded straining wire to be fastened to the outlet chamber of the pump. See the figure below.

Contact the pipe manufacturer or representative to ensure that the pipe type and physical characteristics are suitable for this use.

Use the correct joint compound recommended by the pipe manufacturer. In addition, use a torque arrester when using a plastic pipe.

Do not connect the first plastic or flexible riser pipe section directly to the pump. Always attach a metallic nipple or adapter into the valve casing on the top of the pump. When tightened, make sure that the threaded end of the nipple or adapter does not come in contact with the check valve retainer.

Fasten the submersible drop cable to the riser pipe at frequent intervals to prevent sagging, looping and possible cable damage. Grundfos nylon cable clips or waterproof tape may be used. Protect the cable splice by securing it with Grundfos cable clips or tape just above each joint.

Check valves

Always install a check valve on the top of the well. In addition, for installations deeper than 200 feet (61 m), install check valves at no more than 200 feet (61 m) intervals.

Protect the well from contamination

To protect against surface water entering the well and contaminating the water source, make sure that the well is finished off above grade and that a locally approved well seal or pitless adapter unit is utilized.

6.7 Electrical and variable-frequency drive information

DANGER

Electric shock

Death or serious personal injury

- Switch off the power supply before starting any work on the product.
- Make sure that the power supply cannot be accidentally switched on.

USA and Canada: All electrical work must be performed by a qualified electrician and installed in accordance with the National Electrical Code/ Canadian Electrical Code, local codes and regulations.

DANGER

Electric shock

Death or serious personal injury

- Provide acceptable grounding in order to reduce the risk of electric shock during operation of this pump. If the means of connection to the box connected to the power supply is other than a grounded metal conduit, ground the pump by connecting a copper conductor, at least the size of the circuit supplying the pump, to the grounding screw provided within the terminal box.

Make sure that the voltage, phase number and frequency of the power supply match the motor. Motor voltage, phase number, frequency and full-load current information can be found on the motor nameplate.

The equipment-grounding lead, when one is provided, is the conductor that has an outer surface of insulation that is green with or without one or more yellow stripes.



If voltage variations are larger than $\pm 10\%$, do not operate the pump.

Direct-on-line (DOL) starting is used due to the extremely short run-up time of the motor (maximum 0.1 second), and the low moment of inertia of the pump and motor. DOL starting current (locked rotor current) is between 4 and 6.5 times the full-load current.

If DOL starting is not acceptable and reduced starting current is required, use an autotransformer or resistant starters for 5 to 30 hp motors, depending on the cable length. For motors over 30 hp, use autotransformer starters.

Related information

[10.6.1 Grundfos submersible motors, 60 Hz](#)

6.7.1 Engine-driven generators

If the pump is operated by an engine driven generator, contact the manufacturer of the generator to ensure the proper generator is selected and used. See section [Guide for engine-driven generators in submersible pump applications for generator sizing guide for generator sizing guide](#).

If power is supplied through transformers, section [Transformer capacity required for three-phase submersible motors](#) outlines the minimum KVA rating and capacity required for satisfactory pump operation.

Related information

[10.2 Guide for engine-driven generators in submersible pump applications](#)

[10.3 Transformer capacity required for three-phase submersible motors](#)

6.7.2 Control box or panel wiring

Single-phase motors

Connect single-phase motors as indicated in the motor control box.

A typical single-phase wiring diagram using a Grundfos control box is indicated in the figure below.



Motor burnout protection through CUE, CU331SP, or MP 204.

Use approved dry-run protection, such as MP 204.

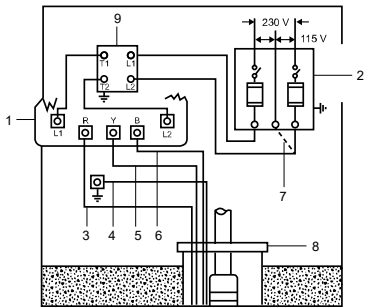

Single-phase wiring diagram for Grundfos control boxes

Pos.	Description
1	Control box
2	Fused disconnect switch
3	Red
4	Green
5	Yellow
6	Black
7	Use dotted line for 115 V operation
8	Well seal
9	Pressure switch

Three-phase motors

Use three-phase motors with the proper motor starter to ensure the motor is protected against damage from low voltage, phase failure, current imbalance and overload current.

Use a proper starter with ambient-compensated, class 10, extra quick-trip overload relays or an MP 204 to provide the best possible motor winding protection.

Each of the three motor legs must be protected with overloads. The thermal overloads must trip in less than 10 seconds at locked rotor (starting) current. A three-phase motor wiring diagram is indicated in the figure below.



Ensure that the pump is completely submerged before checking the direction of rotation. Severe damage may be caused to the pump and motor if they are run dry.

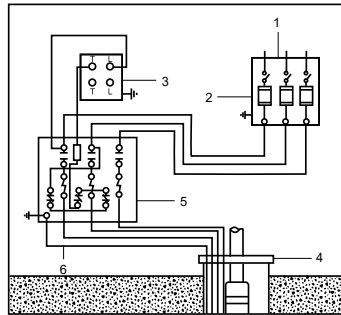

Three-phase wiring diagram for Grundfos motors and other motor manufacturers

Pos.	Description
1	Power supply
2	Fused disconnect switch
3	Pressure switch
4	Well seal
5	Magnetic starter
6	Green

TM050037

TM050038

6.7.3 Variable-frequency drive operation

Grundfos motors

Three-phase Grundfos motors can be connected to a variable frequency drive (VFD).



During variable-frequency drive operation, do not run the motor at a frequency higher than the nominal frequency and not lower than 30 Hz for asynchronous motors or 55 Hz for synchronous motors. In connection with pump operation, never reduce the frequency (and consequently the speed) to such a low level that the necessary flow of the cooling liquid past the motor is no longer ensured.

If a Grundfos MS motor with temperature transmitter is connected to a variable frequency drive, a fuse incorporated in the transmitter melts, and the transmitter becomes inactive. The transmitter cannot be reactivated. This means that from that point on, the motor operates like a motor without a temperature transmitter.



To enable the motor temperature monitoring, install a Pt100 or Pt1000 sensor.



To avoid damage to the pump, make sure that the motor stops when the pump flow falls below 0.1 x rated flow.

Depending on the type of the variable frequency drive, it may expose the motor to detrimental voltage peaks.

The variable frequency drive must have an output sine-wave filter to limit voltage peaks (U_{peak}) and to reduce dU/dt (or dV/dt) which causes stress on the insulation of the submersible motor. For sine-wave filter location placement within the system, see the figure Location of the sine-wave filter in the system.



Protect the motor from voltage peaks (U_{peak}) and excess dU/dt (or dV/dt) by using a sine-wave filter if one or more of the following conditions are present:

- The motor nameplate voltage is above 379 V.
- The variable frequency drive (VFD) uses pulse width modulation (PWM) and/or IGBT-BJT switches.
- The VFD voltage rise time is less than 2 msec (NEMA MG 1-2011).
- The power cable length from the VFD to the submersible motor terminals is 0 to 1500 ft (0 to 457 m).
- The power quality is not stable.
- Keep the motor peak voltage (U_{peak}) and dU/dt within the limits listed in the table below.



For recommended best practice, use a resistor-inductor-capacitor (RLC) type sine-wave filter. An equivalent type LC sine-wave filter is acceptable.

Consult the VFD manufacturer for specific sine-wave filter recommendation.

Maximum peak voltage and dU/dt for Grundfos submersible motors		
Motor series	Maximum U_{peak} voltage	Maximum dU/dt
MS 402	650 V phase-phase	2000 V/micro s.
MS 4000	850 V phase-phase	2000 V/micro s.
MS 6000/MS 6000P	850 V phase-phase	2000 V/micro s.
MMS6	850 V phase-ground	500 V/micro s.
MMS 8000	850 V phase-ground	500 V/micro s.
MMS 10000	850 V phase-ground	500 V/micro s.

For asynchronous motors:

Permissible frequency ranges:

- 30-50 Hz
- 30-60 Hz.

Ramp times: maximum 3 seconds from standstill to minimum frequency and vice versa.

For synchronous motors MS6000P:

Permissible frequency ranges:

- 55-100 Hz
- 55-120 Hz.

Ramp times: maximum 3 seconds from standstill to minimum frequency and vice versa.

Depending on the type, the frequency converter may cause increased acoustic noise from the motor. Furthermore, it may expose the motor to detrimental voltage peaks. This can be abated by installing an LC filter or a sinus filter between the frequency converter and the motor.

For further details, contact your frequency converter supplier or Grundfos.

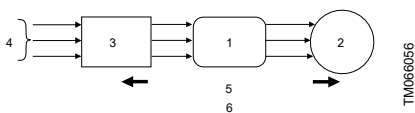

Location of the sine-wave filter in the system

Pos.	Description
1	Sine-wave filter
2	Motor
3	VFD
4	379 V or greater incoming power
5	Cable length from VFD to motor
6	0 to 1500 ft (0 to 457 m)

For further details, contact your VFD supplier or Grundfos.

6.7.4 Setting up the CUE frequency converter in an SPE system

The SPE system consists of the following:

- SPE pump set
- sine-wave filter
- CUE frequency converter.

The CUE has a start up guide. Follow the instructions on the display.

For further information regarding safety and advanced settings, see the CUE Installation and operating instruction.



QR96780034

Installation and operating instructions

<http://net.grundfos.com/qr/i/9780034>

6.7.5 High-voltage surge arresters

Use a high-voltage surge arrester to protect the motor against lightning and switching surges.

Lightning voltage surges in power lines are caused when lightning strikes somewhere in the area.

Switching surges are caused by the opening and closing of switches on the main high-voltage distribution power lines.

Install the correct voltage-rated surge arrester on the supply side of the control box. See the figures below. The arrester must be grounded in accordance with the National Electrical Code/ Canadian Electrical Code and local codes and regulations.

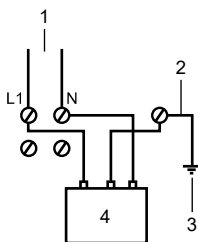

Single-phase installation

Pos.	Description
1	Single-phase power supply
2	Ground
3	True grounding point
4	Lightning arrester

TM050039

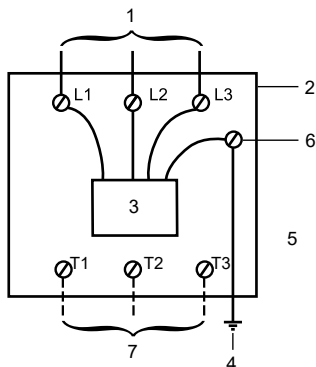

Three-phase installation

Pos.	Description
1	Three-phase power supply
2	Pump control panel
3	Lightning arrester
4	True grounding point
5	Install lightning protectors before fuses or circuit breaker
6	Ground
7	To MS motor

TM050040



The warranty on all three-phase submersible motors becomes void in the following cases:

- The motor is operated with single-phase power through a phase converter.
- Three-leg ambient compensated, extra quick-trip overload protectors are not used.
- Three-phase current imbalance is not checked and recorded.
- High-voltage surge arresters are not installed.

Related information

7. Startup

6.7.6 Control box or panel grounding

DANGER

Electric shock

Death or serious personal injury



- The control box or control panel must be permanently grounded in accordance with the National Electrical Code/ Canadian Electrical Code and local codes or regulations.

The ground wire must be a bare copper conductor at least the same size as the submersible drop cable wire size.

Run the ground wire as short a distance as possible and fasten it securely to a true grounding point.

True grounding points are considered to be one of the following:

- a grounding rod driven into the water strata
- a steel well casing submerged into the water lower than the pump installation depth
- steel outlet pipes without insulating couplings.

If plastic outlet pipe and well casing are used or if a grounding wire is required by local codes, connect a properly sized, bare copper wire to a stud on the motor and run to the control panel.

DANGER

Explosive environment

Death or serious personal injury



- Do not ground to a gas supply line. Connect the grounding wire to the ground point first and then to the terminal in the control box or control panel.

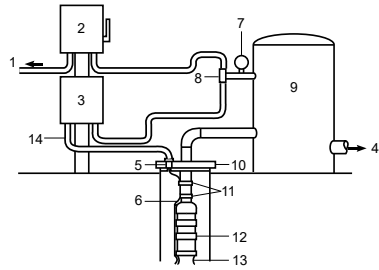

TM005266

Wiring and installation diagram

Pos.	Description
1	Power supply
2	Electrical disconnect box
3	Control box
4	House supply
5	Conduit connector
6	Submersible drop cable
7	Pressure gauge
8	Pressure switch
9	Pressure tank
10	Well seal
11	Tape
12	Pump
13	Motor
14	Conduit*

* Conduit for proper support and protection of the cable against damage between the motor and the point of supply connection.

6.7.7 Wiring checks and installation

Before making the final surface wiring connection of the submersible drop cable to the control box or control panel, it is a good practice to check the insulation resistance to ensure that the cable and splice are good. Measurements for a new installation must be at least 200 megohms. See the table below.

If the insulation resistance of the cable and splice is measured at higher than 200 megohms, run the submersible drop cable through the well seal with a conduit connector to prevent foreign matter from entering the well casing.

Always protect the submersible drop cable with conduit from the pump to the control box or control panel. See the figure Wiring and installation diagram above.

Finish the wiring and make sure that all electrical connections are made according to the wiring diagram.

Make sure that the control box or control panel and high-voltage surge arrester are grounded.

Route conductors properly such as in conduit where called for by Local Code to protect the conductors.

Related information

- [6.7.8 Insulation resistance and ohm value chart](#)
- [6.7.6 Control box or panel grounding](#)

6.7.8 Insulation resistance and ohm value chart

The insulation resistance in a submersible pumping system is a measure of the ability of the motors and/or cables to withstand normal - and transient voltage without breakdown and failure. An "adequate" level of insulation resistance is not a constant value, but depends on the installation voltage and conditions, and whether the measured resistance is lowered by a specific weak point or by widely distributed conductance such as in cable insulation material itself. For this reason, values for acceptable resistance cannot be specific.

Insulation resistance measurements

Measure the insulation resistance at the time of initial motor installation and then periodically. In deep set submersible installations, take measurements throughout the installation process to detect potential cable insulation or connection damage before the unit is completely installed. The insulation resistance table in this section describes the condition of the insulation system for a submersible motor system of 600 V or less, based on megohmmeter readings.



Measure the insulation resistance according to local codes and regulations.

The table below indicates suggested values of insulation resistance and the test voltage in relation to the rated voltage of the motor.

Rated voltage	≤ 500 [V]	> 500 [V]
Condition of motor and cable	[MΩ]	[MΩ]
New motor without submersible drop cable	≥ 200	≥ 200
Used motor which can be re-installed in a well	≥ 10	≥ 10
New motor in a well	≥ 20	≥ 20
Motor in good condition in a well	≥ 0.5	≥ 1
Damaged insulation	< 0.5	< 1

If the rated motor voltage is less than or equal to 500 V, the insulation resistance must be measured at a test voltage of 500 VDC.

If the rated motor voltage is greater than 500 V, the insulation resistance must be measured at a test voltage of 1000 VDC.

7. Startup

After the pump is set into the well and the wiring connections have are made, go through the following procedures:

1. Attach a temporary horizontal length of pipe with installed gate valve to the riser pipe.
2. Adjust the gate valve one-third of the way open.
3. On three-phase units, check direction of rotation and current imbalance according to the instructions below. For single-phase units proceed directly to section Developing the well.
4. Do not operate the pump with the outlet valve closed. This can result in damage to the motor and the pump due to overheating. Install a properly sized relief valve at the well head to prevent the pump from running against a closed valve.

Related information

- [7.1.3 Developing the well](#)

7.1 Startup with three-phase motors

7.1.1 Check the direction of rotation

Three-phase motors can run in either direction depending on how they are connected to the power supply. To make sure the motor is running in the proper direction, follow the procedures below:

1. Start the pump and check the water quantity and pressure.
2. Stop the pump and interchange any two leads.
3. Start the pump and again check the water quantity and pressure.

- Compare the results observed. The wire connection which gives the highest pressure and largest water quantity is the correct connection.

7.1.2 Check for current imbalance

Current imbalance causes the motor to have reduced starting torque, overload tripping, excessive vibration and poor performance which can result in early motor failure. It is very important that current imbalance be checked in all three-phase systems.



Make sure that the current imbalance between the phases do not exceed 5 % under normal operating conditions.

Determine if the supply power service is a two-transformer or three-transformer system. If two transformers are present, the system is an "open" delta or wye. If three transformers are present, the system is true three-phase.

Make sure the transformer ratings in kilovolt amps (KVA) is sufficient for the motor load. See section Transformer capacity required for three-phase submersible motors.

The percentage of current imbalance can be calculated with the following formulas and procedures:

$$\text{Average current} = \frac{\text{Total of current values measured on each leg}}{3}$$

$$\% \text{ current imbalance} = \frac{\text{Greatest amp difference from the average}}{\text{Average current}} \times 100$$

To determine the percentage of current imbalance, proceed as follows:

- Measure and record current readings in amps for each leg (hookup 1). Disconnect the power.
- Shift or roll the motor leads from left to right so the submersible drop cable lead that was on terminal 1 is now on 2, lead on 2 is now on 3, and lead on 3 is now on 1 (hookup 2). Rolling the motor leads this way does not reverse the motor rotation. Start the pump, measure and record current reading on each leg. Disconnect the power.
- Shift submersible drop cable leads from left to right so the lead on terminal 1 goes to 2, 2 to 3 and 3 to 1 (hookup 3). Start the pump, measure and record current reading on each leg. Disconnect the power.
- Add the values for each hookup.
- Divide the total by 3 to obtain the average.
- Compare each single leg reading from the average to obtain the greatest amp difference.

- Divide this difference by the average to obtain the percentage of imbalance.

Use the wiring hookup which provides the lowest percentage of imbalance. See section Correcting for three-phase current imbalance for a specific example of correcting for three-phase current imbalance.

Related information

[10.3 Transformer capacity required for three-phase submersible motors](#)

[10.6.3 Correcting for three-phase current imbalance](#)

7.1.3 Developing the well

After proper rotation and current imbalance are checked, start the pump and let it operate until the water runs clear of sand, silt and other impurities.

Slowly open the valve in small increments as the water clears until the desired flow rate is reached. Do not operate the pump beyond its maximum flow rating.



Do not stop the pump until the water runs clear.

If the water is clean and clear when the pump is first started, open the valve slowly until the desired flow rate is reached. As the valve is being opened, check the drawdown to ensure that the pump is always submerged.



Make sure that the dynamic water level is always more than 3 feet (0.9 m) above the suction interconnector of the pump.

Disconnect the temporary piping arrangements and complete the final piping connections.



Do not operate the pump with the outlet valve closed. This can result in damage to the motor and the pump due to overheating. Install a properly sized relief valve at the well head to prevent the pump from running against a closed valve.

Start the pump and test the system. Check and record the voltage and current draw on each motor lead.

8. Operating the product

Check the pump and system periodically for water quantity, pressure, drawdown, periods of cycling and operation of controls.

Related information

[9. Troubleshooting](#)

8.1 Minimum flow rate

To ensure the adequate cooling of the motor, do not set the pump flow rate so low that the cooling requirements specified in section cannot be met.

Related information

[6.2.2 Pumped liquids](#)

8.1.1 Frequency of starts and stops

Motor type	Number of starts
MS402	Minimum 1 per year. Maximum 100 per hour. Maximum 300 per day.
MS4000	Minimum 1 per year. Maximum 100 per hour. Maximum 300 per day.
MS6000	Minimum 1 per year. Maximum 30 per hour. Maximum 300 per day.
MS6000P	Minimum 1 per year. Maximum 120 per hour. Maximum 360 per day.
MMS6	Minimum 1 per year. Maximum 10 per hour. Maximum 70 per day.
MMS8000	Minimum 1 per year is. Maximum 8 per hour. Maximum 60 per day.
MMS10000	Minimum 1 per year is. Maximum 6 per hour. Maximum 50 per day.

8.2 Soft starter

The starting voltage is minimum 55 % of the value stated on the nameplate.

If a high locked-rotor torque is required or if the power supply is not optimal, the starting voltage must be higher.

Run-out time: Maximum 3 seconds.

If the above-mentioned run-up and run-out ramps are followed, unnecessary heating of the motor is avoided.

If the soft starter is fitted with bypass contacts, the soft starter is in operation during run-up and run-out.

Do not use the soft starter in connection with operation with a generator.

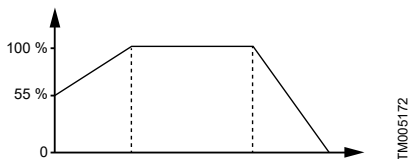

Operation with a soft starter

Pos.	Description
1	Voltage
2	Time
3	3 seconds
4	3 seconds

8.3 Maintenance and service

All pumps are easy to service.

Service kits and service tools are available from Grundfos.

The pumps can be serviced at a Grundfos service center.

DANGER

Toxic or radio active liquid

Death or serious personal injury

- If a pump has been used for a liquid which is injurious to health or toxic, the pump will be classified as contaminated.

Contact Grundfos with details about the pumped liquid before returning the product for service. Otherwise Grundfos can refuse to accept the product.

Possible costs of returning the pump are paid by the customer.

8.3.1 SPE

The following is only valid for SPE pump sets.

DANGER

Magnetic field

Death or serious personal injury

- Do not handle the rotor if having a pacemaker.



DANGER

Crushing of hands

Death or serious personal injury

- Keep the rotor surroundings free of magnetic objects and be careful when placing the rotor on a magnetic surface.



DANGER

Electric shock

Death or serious personal injury

- Make sure that motor cable ends are not live before starting work on the product.
- Make sure that the power supply cannot be accidentally switched on.



In case of unintended water flow through a non-energized pump, there is a risk that the moving parts of the pump and the motor may start rotating, and generate voltage over the terminals. The size of the voltage depends on the rotation speed. Therefore, the motor terminals must be considered as live until proven otherwise.

9. Troubleshooting

The majority of problems that develop with submersible pumps are electrical, and most of these problems can be corrected without pulling the pump from the well. The following chart covers most of the submersible service work. Start with the simplest solution first; always make all the above-ground checks before pulling the pump from the well.

Usually only two instruments are needed:

- a combination of voltmeter and ammeter
- an ohmmeter.

DANGER

Electric shock

Death or serious personal injury



- Use rubber gloves and boots and make sure to have metal control boxes and motors grounded to power supply ground or steel drop pipe or casing extending into the well.

DANGER

Electric shock

Death or serious personal injury



- Submersible motors are intended for operation in a well. When not operated in a well, failure to connect motor frame to power supply ground may result in serious electric shock.

9.1 SPE

The following is only valid for SPE pump sets.

DANGER

Magnetic field

Death or serious personal injury



- Do not handle the rotor if having a pacemaker.

DANGER

Crushing of hands

Death or serious personal injury



- Keep the rotor surroundings free of magnetic objects and be careful when placing the rotor on a magnetic surface.

DANGER

Electric shock



Death or serious personal injury



- Make sure that motor cable ends are not live before starting work on the product.
- Make sure that the power supply cannot be accidentally switched on.

In case of unintended water flow through a non-energized pump, there is a risk that the moving parts of the pump and the motor may start rotating, and generate voltage over the terminals. The size of the voltage depends on the rotation speed. Therefore, the motor terminals must be considered as live until proven otherwise.

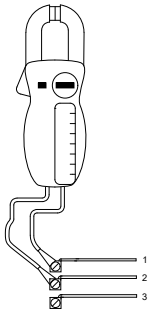
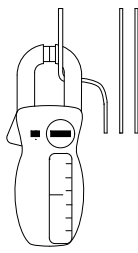
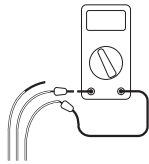
9.2 Preliminary tests

Test	How to measure	What it means
<p data-bbox="122 170 250 194">Supply voltage</p>  <p data-bbox="292 462 313 527">TM001371</p>	<p data-bbox="324 267 606 341">With a voltmeter set to the proper scale, measure the voltage at the control box or starter.</p> <p data-bbox="324 349 595 389">On single-phase units, measure between line and neutral.</p> <p data-bbox="324 397 585 438">On three-phase units, measure between the legs (phases).</p>	<p data-bbox="665 219 962 332">When the motor is under load, the voltage must be within $\pm 10\%$ of the value stated on the nameplate. Larger voltage variation may cause winding damage.</p> <p data-bbox="665 341 989 495">Large variations in the voltage indicate a poor power supply and the pump must not be operated until these variations are corrected. If the voltage constantly remains high or low, the motor must be changed to the correct supply voltage.</p>
<p data-bbox="122 576 191 600">Current</p>  <p data-bbox="292 803 313 868">TM001372</p>	<p data-bbox="324 641 622 755">With an ammeter set to the proper scale, measure the current on each power lead at the control box or starter. See section for motor amp draw information.</p> <p data-bbox="324 763 643 828">Current must be measured when the pump is operating at a constant outlet pressure with the motor fully loaded.</p>	<p data-bbox="665 560 984 665">If the amp draw exceeds the listed service factor amps (SFA), or if the current imbalance is greater than 5% between each leg on three-phase units, check the following:</p> <ul data-bbox="665 673 994 909" style="list-style-type: none"> • Burnt contacts on motor-protective circuit breaker. • Loose terminals in starter or control box or possible cable defect. Check winding and insulation resistances. • Supply voltage too high or low. • Motor windings are shortened. • Pump is damaged, causing a motor overload.
<p data-bbox="122 982 287 1006">Winding resistance</p>  <p data-bbox="292 1096 313 1193">TM050028_0511</p>	<p data-bbox="324 925 622 990">Turn off power and disconnect the submersible drop cable leads in the control box or starter.</p> <p data-bbox="324 998 627 1079">With an ohmmeter, set the scale selectors to Rx1 for values under 10 ohms and Rx10 for values over 10 ohms.</p> <p data-bbox="324 1088 601 1153">Zero-adjust the ohmmeter and measure the resistance between leads. Record the values.</p> <p data-bbox="324 1161 643 1274">Motor resistance values can be found in section Insulation resistance and ohm value chart. Cable resistance values are in section Insulation resistance and ohm value chart.</p>	<p data-bbox="665 925 978 990">If all the ohm values are normal, and the cable colors correct, the windings are not damaged.</p> <p data-bbox="665 998 968 1039">If the ohm value is less than normal, the motors may be shorted.</p> <p data-bbox="665 1047 968 1136">If the ohm value is greater than normal, there is a poor cable connection or joint. The windings or cable may also be open.</p> <p data-bbox="665 1144 984 1274">If some of the ohm values are greater than normal and some less, the submersible drop cable leads are mixed. To verify lead colors, see resistance values in section Insulation resistance and ohm value chart.</p>
<p data-bbox="122 1307 297 1331">Insulation resistance</p>  <p data-bbox="292 1364 313 1469">TM050029_0511</p>	<p data-bbox="324 1291 622 1356">Turn off power and disconnect the submersible drop cable leads in the control box or starter.</p> <p data-bbox="324 1364 638 1421">With an ohmmeter or megohmmeter, set the scale selector to Rx 100K and zero adjust the meter.</p> <p data-bbox="324 1429 633 1494">Measure the resistance between the lead and ground (discharge pipe or well casing, if steel).</p>	<p data-bbox="665 1323 989 1388">For ohm values, refer to section Insulation resistance and ohm value chart..</p> <p data-bbox="665 1396 968 1461">Motors of all hp, voltage, phase and cycle duties have the same value of insulation resistance.</p>

Related information

[6.7.8 Insulation resistance and ohm value chart](#)

[6.7.8 Insulation resistance and ohm value chart](#)

[9.3 Checking pump performance](#)

9.3 Checking pump performance

Test the pump performance against its curve based on the Troubleshooting chart below. Perform the following steps:

1. Install a pressure gauge.
2. Start the pump.
3. Gradually close the outlet valve.
4. Read pressure at shut-off.

5. After reading, open the valve to its previous position.
6. To calculate pump performance, first convert psi reading to feet. For water: $\text{psi} \times 2.31 = \text{feet}$.
7. Add this to the total vertical distance from the pressure gauge to the water level in the well while the pump is running.
8. Refer to the specific pump curve for the shut-off head (pressure) for that pump model. If the measured head is close to the curve, the pump is OK.

9.4 Troubleshooting the product**9.4.1 The pump does not run**

Cause	Remedy
Supply failure.	<ul style="list-style-type: none"> • Connect the power supply.
The fuses are blown.	<ul style="list-style-type: none"> • Replace the fuses.
The motor-protective circuit breaker has tripped.	<ul style="list-style-type: none"> • Reactivate the motor-protective circuit breaker.
The thermal protection has tripped.	<ul style="list-style-type: none"> • Reactivate the thermal protection.
The main contacts in the motor-protective circuit breaker are not making contact or the coil is faulty.	<ul style="list-style-type: none"> • Replace the contacts or the magnetic coil.
The control circuit is defective.	<ul style="list-style-type: none"> • Repair the control circuit.
The controls are defective.	<ul style="list-style-type: none"> • Replace worn or defective parts.
The motor and/or cable are defective.	<ul style="list-style-type: none"> • If an open motor winding or ground is found, pull the pump from the well and re-check values at the surface. • Repair or replace the motor or cable.
The capacitor is defective (single-stage only).	<ul style="list-style-type: none"> • Check the capacitor with an ohmmeter • If there is no ohmmeter needle movement, replace the capacitor.

9.4.2 The pump runs but does not deliver water

Cause	Remedy
The groundwater level in the well is too low.	<ul style="list-style-type: none"> • Lower the pump so the water level is at least 3 feet above the suction interconnector or install a water level control.
The integral pump check valve is blocked.	<ul style="list-style-type: none"> • Pull the pump from the well. • Remove the blockage. • Repair the valve and the valve seat, if necessary, and check for other damage. • Rinse out the pump and re-install it.
The inlet strainer is clogged.	<ul style="list-style-type: none"> • Pull the pump from the well. • Clean the inlet strainer. • Rinse out the pump and re-install it.
The pump is damaged.	<ul style="list-style-type: none"> • Pull the pump from the well. • Repair as necessary. • Rinse out the pump and re-install it.

9.4.3 The pump runs, but at reduced capacity

Cause	Remedy
The direction of rotation is wrong (three-phase only).	<ul style="list-style-type: none"> Correct the wiring and change the leads as required.
The drawdown is larger than anticipated.	<ul style="list-style-type: none"> Lower the pump so the water level is at least 3 feet above the suction interconnector or install a water level control.
The outlet piping or the valve are leaking.	<ul style="list-style-type: none"> Repair the leaks.
The integral pump check valve is blocked.	<ul style="list-style-type: none"> Pull the pump from the well. Remove the blockage. Repair the valve and the valve seat, if necessary, and check for other damage. Rinse out the pump and re-install it.
The inlet strainer is clogged.	<ul style="list-style-type: none"> Pull the pump from the well. Clean the inlet strainer. Rinse out the pump and re-install it.
The pump is worn.	<ul style="list-style-type: none"> Pull the pump from the well. Repair as necessary. Rinse out the pump and re-install it.

9.4.4 The pump cycles too much

Cause	Remedy
The pressure switch is not properly adjusted or is defective.	<ul style="list-style-type: none"> Re-adjust the switch or replace it if it is defective.
The level control is not properly set or is defective.	<ul style="list-style-type: none"> Re-adjust the setting; refer to the manufacturer data. Replace the level control if it is defective.
The pressure in the diaphragm tank is insufficient or the tank or piping is leaking.	<ul style="list-style-type: none"> Repair or replace any damaged components.
The snifter valve or bleed orifice are plugged.	<ul style="list-style-type: none"> Clean and/or replace any defective snifter valve or bleed orifice.
The tank is too small.	<ul style="list-style-type: none"> Replace it with a proper size tank.

9.4.5 Fuses blow or circuit breakers trip

Cause	Remedy
The voltage is too high or low.	<ul style="list-style-type: none"> If the cable size is correct, contact the power company. If not, correct and/or replace as necessary.
The three-phase current imbalance is too high.	<ul style="list-style-type: none"> If current imbalance is not within $\pm 5\%$, contact the power supply company.
The control box wiring and components are incorrect or defective (single-phase only).	<ul style="list-style-type: none"> Correct as required.
The capacitor is defective (single-phase only).	<ul style="list-style-type: none"> Check the capacitor with an ohmmeter. If there is no ohmmeter needle movement, replace the capacitor.
The starting relay is defective (certain types of single-phase only).	<ul style="list-style-type: none"> Replace any defective starting relay.

10. Technical data

10.1 Motor cooling requirements

10.1.1 Maximum water temperature - minimum velocity/flow past the motor

Maximum water temperature - minimum velocity/flow past the motor					
Motor type	Minimum well casing or sleeve diameter	Minimum velocity	Minimum flow	Maximum temperature of the pumped liquid	
				Vertical installation	Horizontal installation
	[in (mm)]	[ft/s (m/s)]	[gpm (m ³ /h)]	[°F (°C)]	[°F (°C)]
MS 402 / MS 4000	4 (102)	0.00 (0.00)	0.0 (0.0)	86 (30)	Flow sleeve recommended *
MS 402 / MS 4000	4 (102)	0.25 (0.08)	1.2 (0.27)	104 (40)	104 (40)
MS 6000 (T40)	6 (152)	0.50 (0.15)	9 (2)	104 (40)	104 (40)
MS 6000 (T60)	6 (152)	3.30 (1.00)	30 (6.8)	140 (60)	140 (60)
MS 6000P	6 (152)	0.50 (0.15)	9 (2)	140 (60)	140 (60)
MMS 6 (T30)	6 (152)	0.15 (0.05)	13 (3)	86 (30)	86 (30)
MMS 6 (T50)	6 (152)	0.15 (0.05)	13 (3)	122 (50)	122 (50)
MMS 8000 (T30)	8 (203)	0.50 (0.15)	25 (5.7)	86 (30)	86 (30)
MMS 6 (T50)	8 (203)	0.50 (0.15)	25 (5.7)	122 (50)	122 (50)
MS 10000 (175, 200 hp)	10 (254)	0.50 (0.15)	55 (12.5)	86 (30)	86 (30)
MS 10000 (250 hp)	10 (254)	0.50 (0.15)	41 (9.3)	68 (20)	68 (20)

* A flow inducer or flow sleeve must be used if the water enters the well above the motor or if there is insufficient water flow past the motor.

ft/s = feet per second



For MMS6, 50 hp and MMS 8000, 150 hp, the maximum liquid temperature is 9 °F (5 °C) lower than the values stated in the above table. For MMS10000, 250 hp, temperature is 18 °F (10 °C) lower.

10.2 Guide for engine-driven generators in submersible pump applications

1- or 3-phase motor [Hp]	Generator [kW]	
	Externally regulated	Internally regulated
0.33	1.5	1.2
0.5	2.0	1.5
0.75	3.0	2.0
1	4.0	2.5
1.5	5.0	3.0
2	7.5	4.0
3	10.0	5.0
5.0	15.0	7.5
7.5	20.0	10.0
10.0	30.0	15.0
15.0	40.0	20.0
20.0	60.0	25.0
25.0	75.0	30.0
30.0	100.0	40.0
40.0	100.0	50.0
50.0	150.0	60.0
60.0	175.0	75.0
75.0	250.0	100.0
100.0	300.0	150.0
125.0	375.0	175.0
150.0	450.0	200.0
200.0	600.0	275.0

Note:

- The table is based on typical +176 °F (+80 °C) rise continuous duty generators with 35 % maximum voltage dip during the startup of single- and three-phase motors.
- Contact the manufacturer of the generator to make sure the unit has adequate capacity to run the submersible motor.
- If the generator rating is in KVA instead of kilowatts, multiply the above ratings by 1.25.

10.3 Transformer capacity required for three-phase submersible motors

3-phase motor [Hp]	Minimum total KVA required *	Minimum KVA rating for each transformer	
		Two transformers Open Delta or Wye	Three transformers Delta or Wye
1.5	3	2	1
2	4	2	1.5
3	5	3	2
5	7.5	5	3
7.5	10	7.5	5
10	15	10	5
15	20	15	7.5
20	25	15	10
25	30	20	10
30	40	25	15
40	50	30	20
50	60	35	20
60	75	40	25
75	90	50	30
100	120	65	40
125	150	85	50
150	175	100	60
200	230	130	75

* Pump motor KVA requirements only, and does not include allowances for other loads.

10.4 Submersible drop cable selection charts (60 Hz)

The following tables indicate the recommended copper conductor sizes and various cable lengths for submersible motors.

These tables comply with the 1978 edition of the National Electric Table 310-16, Column 2 for +167 °F (+75 °C) wire. The ampacity (current carrying properties of a conductor) have been divided by 1.25 per the N.E.C., Article 430-22, for motor branch circuits based on motor amps at rated horsepower.

To ensure adequate starting torque, the maximum cable lengths are calculated to maintain 95 % of the service entrance voltage at the motor when the motor is running at maximum value stated on the nameplate. Cable sizes larger than specified may always be used and reduce power consumption.



Using cables smaller than the recommended sizes void the warranty. Smaller cable sizes may cause reduced starting torque and poor motor operation.

10.4.1 115 V and 230 V, 1-phase, 60 Hz

		Maximum submersible power cable length (maximum cable length in feet, starter to motor)												
Motor rating	[Hp]	AWG copper wire size												
		14	12	10	8	6	4	3	2	1	0	00	000	0000
115 V 1-ph 60 Hz	0.33	130	210	340	540	840	1300	1610	1960	2390	2910	3540	4210	5060
		(40)	(64)	(104)	(165)	(256)	(396)	(491)	(597)	(728)	(887)	(1079)	(1283)	(1542)
	0.5	100	160	250	390	620	960	1190	1460	1780	2160	2630	3140	3770
		(30)	(49)	(76)	(119)	(189)	(293)	(363)	(445)	(543)	(658)	(802)	(957)	(1149)
	0.33	550	880	1390	2190	3400	5250	6520	7960	9690	11770	14320	17050	20460
		(168)	(268)	(424)	(668)	(1036)	(1600)	(1987)	(2426)	(2954)	(3587)	(4365)	(5197)	(6236)
	0.5	400	650	1020	1610	2510	3880	4810	5880	7170	8720	10620	12660	15210
		(122)	(198)	(311)	(491)	(765)	(1183)	(1466)	(1792)	(2185)	(2658)	(3237)	(3859)	(4636)
	0.75	300	480	760	1200	1870	2890	3580	4370	5330	6470	7870	9380	11250
		(91)	(146)	(232)	(366)	(570)	(881)	(1091)	(1332)	(1625)	(1972)	(2399)	(2859)	(3429)
1	250	400	630	990	1540	2380	2960	3610	4410	5360	6520	7780	9350	
	(76)	(122)	(192)	(302)	(469)	(725)	(902)	(1100)	(1344)	(1634)	(1987)	(2371)	(2850)	
1.5	190	310	480	770	1200	1870	2320	2850	3500	4280	5240	6300	7620	
	(58)	(94)	(146)	(235)	(366)	(570)	(707)	(869)	(1067)	(1305)	(1597)	(1920)	(2323)	
2	150	250	390	620	970	1530	1910	2360	2930	3620	4480	5470	6700	
	(46)	(76)	(119)	(189)	(296)	(466)	(582)	(719)	(893)	(1103)	(1366)	(1667)	(2042)	
3	120	190	300	470	750	1190	1490	1850	2320	2890	3610	4470	5550	
	(37)	(58)	(91)	(143)	(229)	(363)	(454)	(564)	(707)	(881)	(1100)	(1362)	(1692)	
5	-	110*	180	280	450	710	890	1110	1390	1740	2170	2680	3330	
		(34*)	(55)	(85)	(137)	(216)	(271)	(338)	(424)	(530)	(661)	(817)	(1015)	
7.5	-	-	120*	200	310	490	610	750	930	1140	1410	1720	2100	
			(37*)	(61)	(94)	(149)	(186)	(229)	(283)	(347)	(430)	(524)	(640)	
10	-	-	-	160*	250	390	490	600	750	930	1160	1430	1760	
				(49*)	(76)	(119)	(149)	(183)	(229)	(283)	(354)	(436)	(536)	
15	-	-	-	-	170*	270	340	430	530	660	820	1020	1260	
					(52*)	(82)	(104)	(131)	(162)	(201)	(250)	(311)	(384)	

* Indicates single conductor only (not jacketed).

Note:

No asterisk indicates both jacketed cable and single conductor cables.

- The table is based on copper wire. If aluminum wire is used, multiply lengths by 0.5. The maximum allowable length of aluminum is considerably shorter than the same copper wire size.
- Make sure that the portion of the total cable, which is between the service entrance and a motor starter/controller, does not exceed 25 % of the total maximum length to ensure reliable starter operation. Single-phase control boxes may be connected at any point of the total cable length.
- The table is based on maintaining motor terminal voltage at 95 % of the service entrance voltage, running at the

maximum value stated on the nameplate. In general, a voltage drop must be maintained at 3 V / 100 ft or less.

- 1 foot = 0.305 meter (1 meter = 3.28 feet).

10.4.2 200-208 V, 3-phase, 60 Hz

		Maximum submersible power cable length (maximum cable length in feet, starter to motor)												
Motor rating	[Hp]	AWG copper wire size												
		14	12	10	8	6	4	3	2	1	0	00	000	0000
200-208 V 3-ph 60 Hz	0.5	710 (216)	1140 (347)	1800 (549)	2840 (866)	4420 (1347)	-	-	-	-	-	-	-	-
	0.75	510 (155)	810 (245)	1280 (390)	2030 (619)	3160 (963)	-	-	-	-	-	-	-	-
	1	430 (131)	690 (210)	1080 (329)	1710 (521)	2670 (814)	4140 (1262)	5140 (1567)	-	-	-	-	-	-
	1.5	310 (94)	500 (152)	790 (241)	1260 (384)	1960 (597)	3050 (930)	3780 (1152)	-	-	-	-	-	-
	2	240 (73)	390 (119)	610 (186)	970 (296)	1520 (463)	2360 (719)	2940 (896)	3610 (1100)	4430 (1350)	5420 (1652)	-	-	-
	3	180 (55)	290 (88)	470 (143)	740 (226)	1160 (354)	1810 (552)	2250 (686)	2760 (841)	3390 (1033)	4130 (1259)	-	-	-
	5	110 [*] (34 [*])	170 (52)	280 (85)	440 (134)	690 (210)	1080 (329)	1350 (411)	1660 (506)	2040 (622)	2490 (759)	3050 (930)	3670 (1119)	4440 (1353)
	7.5	-	-	200 (61)	310 (94)	490 (149)	770 (235)	960 (293)	1180 (360)	1450 (442)	1770 (539)	2170 (661)	2600 (792)	3150 (960)
	10	-	-	-	230 [*] (70 [*])	370 (113)	570 (174)	720 (219)	880 (268)	1090 (332)	1330 (405)	1640 (500)	1970 (600)	2390 (728)
	15	-	-	-	160 [*] (49 [*])	250 [*] (76 [*])	390 (119)	490 (149)	600 (183)	740 (226)	910 (277)	1110 (338)	1340 (408)	1630 (497)
	20	-	-	-	-	190 [*] (58 [*])	300 [*] (91 [*])	380 (116)	460 (140)	570 (174)	700 (213)	860 (262)	1050 (320)	1270 (387)
	25	-	-	-	-	-	240 [*] (73 [*])	300 [*] (91 [*])	370 [*] (113 [*])	460 (140)	570 (174)	700 (213)	840 (256)	1030 (314)
	30	-	-	-	-	-	-	250 [*] (76 [*])	310 [*] (94 [*])	380 [*] (116 [*])	470 (143)	580 (177)	700 (213)	850 (259)

* Indicates single conductor only (not jacketed).

Note:

No asterisk indicates both jacketed cable and single conductor cables.

- The table is based on copper wire. If aluminum wire is used, multiply lengths by 0.5. The maximum allowable length of aluminum is considerably shorter than the same copper wire size.
- Make sure that the portion of the total cable, which is between the service entrance and a motor starter/controller, does not exceed 25 % of the total maximum length to ensure reliable starter operation. Single-phase control boxes may be connected at any point of the total cable length.

- The table is based on maintaining motor terminal voltage at 95 % of service entrance voltage, running at the maximum value stated on the nameplate. In general, a voltage drop must be maintained at 3 V / 100 ft or less.
- 1 foot = 0.305 meter (1 meter = 3.28 feet).

10.4.3 230 V, 3-phase, 60 Hz

		Maximum submersible power cable length (maximum cable length in feet, starter to motor)												
Motor rating	[Hp]	AWG copper wire size												
		14	12	10	8	6	4	3	2	1	0	00	000	0000
230 V 3-ph 60 Hz	0.5	930 (283)	1490 (454)	2350 (716)	3700 (1128)	5760 (1756)	8910 (2716)	-	-	-	-	-	-	-
	0.75	670 (204)	1080 (329)	1700 (518)	2580 (786)	4190 (1277)	6490 (1978)	8060 (2457)	9860 (3005)	-	-	-	-	-
	1	560 (171)	910 (277)	1430 (436)	2260 (689)	3520 (1073)	5460 (1664)	6780 (2067)	8290 (2527)	-	-	-	-	-
	1.5	420 (128)	670 (204)	1060 (323)	1670 (509)	2610 (796)	4050 (1234)	5030 (1533)	6160 (1878)	7530 (2295)	9170 (2795)	-	-	-
	2	320 (98)	510 (155)	810 (247)	1280 (390)	2010 (613)	3130 (954)	3890 (1186)	4770 (1454)	5860 (1786)	7170 (2185)	8780 (2676)	-	-
	3	240 (73)	390 (119)	620 (189)	990 (302)	1540 (469)	2400 (732)	2980 (908)	3660 (1116)	4480 (1366)	5470 (1667)	6690 (2039)	8020 (2444)	9680 (2950)
	5	140 [*] (43 [*])	230 (70)	370 (113)	590 (180)	920 (280)	1430 (436)	1790 (546)	2190 (668)	2690 (820)	3290 (1003)	4030 (1228)	4850 (1478)	5870 (1789)
	7.5	-	160 [*] (49 [*])	260 (79)	420 (128)	650 (198)	1020 (311)	1270 (387)	1560 (475)	1920 (585)	2340 (713)	2870 (875)	3440 (1049)	4160 (1268)
	10	-	-	190 [*] (58 [*])	310 (94)	490 (149)	760 (232)	950 (290)	1170 (357)	1440 (439)	1760 (536)	2160 (658)	2610 (796)	3160 (963)
	15	-	-	-	210 [*] (64 [*])	330 (101)	520 (158)	650 (198)	800 (244)	980 (299)	1200 (366)	1470 (448)	1780 (543)	2150 (655)
	20	-	-	-	-	250 [*] (76 [*])	400 (122)	500 (152)	610 (186)	760 (232)	930 (283)	1140 (347)	1380 (421)	1680 (512)
	25	-	-	-	-	-	320 [*] (98 [*])	400 (122)	500 (152)	610 (186)	750 (229)	920 (280)	1120 (341)	1360 (415)
	30	-	-	-	-	-	260 [*] (79 [*])	330 [*] (101 [*])	410 [*] (125 [*])	510 (155)	620 (189)	760 (232)	930 (283)	1130 (344)

* Indicates single conductor only (not jacketed).

Note:

No asterisk indicates both jacketed cable and single-conductor cables.

- The table is based on copper wire. If aluminum wire is used, multiply lengths by 0.5. The maximum permissible length of aluminum is considerably shorter than the same copper wire size.
- Make sure that the portion of the total cable, which is between the service entrance and a motor starter/controller, does not exceed 25 % of the total maximum length to ensure reliable starter operation. Single-phase control boxes may be connected at any point of the total cable length.

- The table is based on maintaining motor terminal voltage at 95 % of service entrance voltage, running at the maximum value stated on the nameplate. In general, a voltage drop must be maintained at 3 V / 100 ft or less.
- 1 foot = 0.305 meter (1 meter = 3.28 feet).

10.4.4 460 V, 3-phase, 60 Hz

		Maximum submersible power cable length (maximum cable length in feet, starter to motor)												
Motor rating	[Hp]	AWG copper wire size												
		14	12	10	8	6	4	3	2	1	0	00	000	0000
		[ft (m)]												
460 V 3-ph 60 Hz	0.5	3770 (1149)	6020 (1835)	9460 (2883)	-	-	-	-	-	-	-	-	-	-
	0.75	2730 (832)	4350 (1326)	6850 (2088)	-	-	-	-	-	-	-	-	-	-
	1	2300 (701)	3670 (1119)	5770 (1759)	9070 (2765)	-	-	-	-	-	-	-	-	-
	1.5	1700 (518)	2710 (826)	4270 (1301)	6730 (2051)	-	-	-	-	-	-	-	-	-
	2	1300 (396)	2070 (631)	3270 (997)	5150 (1570)	8050 (2454)	-	-	-	-	-	-	-	-
	3	1000 (305)	1600 (488)	2520 (768)	3970 (1210)	6200 (1890)	-	-	-	-	-	-	-	-
	5	590 (180)	950 (290)	1500 (457)	2360 (719)	3700 (1128)	5750 (1753)	-	-	-	-	-	-	-
	7.5	420 (128)	680 (207)	1070 (326)	1690 (515)	2640 (805)	4100 (1250)	5100 (1554)	6260 (1908)	7680 (2341)	-	-	-	-
	10	310 (94)	500 (152)	790 (241)	1250 (381)	1960 (597)	3050 (930)	3800 (1158)	4680 (1426)	5750 (1753)	7050 (2149)	-	-	-
	15	-	340* (104*)	540 (165)	850 (259)	1340 (408)	2090 (637)	2600 (792)	3200 (975)	3930 (1198)	4810 (1466)	5900 (1798)	7110 (2167)	-
	20	-	-	410 (125)	650 (198)	1030 (314)	1610 (491)	2000 (610)	2470 (753)	3040 (927)	3730 (1137)	4580 (1396)	5530 (1686)	-
	25	-	-	330* (101*)	530 (162)	830 (253)	1300 (396)	1620 (494)	1990 (607)	2450 (747)	3010 (917)	3700 (1128)	4470 (1362)	5430 (1655)
	30	-	-	270** (82*)	430 (131)	680 (207)	1070 (326)	1330 (405)	1640 (500)	2030 (619)	2490 (759)	3060 (933)	3700 (1128)	4500 (1372)
	40	-	-	-	320* (98*)	500* (152*)	790 (241)	980 (299)	1210 (369)	1490 (454)	1830 (558)	2250 (686)	2710 (826)	3290 (1003)
50	-	-	-	-	410* (125*)	640 (195)	800 (244)	980 (299)	1210 (369)	1480 (451)	1810 (552)	2190 (668)	2650 (808)	
60	-	-	-	-	-	540* (165*)	670* (204*)	830 (253)	1020 (311)	1250 (381)	1540 (469)	1850 (564)	2240 (683)	
75	-	-	-	-	-	440* (134*)	550* (168*)	680* (207*)	840 (256)	1030 (314)	1260 (384)	1520 (463)	1850 (564)	
100	-	-	-	-	-	-	-	500* (152*)	620* (189*)	760* (232*)	940 (287)	1130 (344)	1380 (421)	

125	-	-	-	-	-	-	-	-	-	-	600*	740*	890*	1000
											(183*)	(226*)	(271*)	(305)
150	-	-	-	-	-	-	-	-	-	-	630*	760*	920*	
											(192*)	(232*)	(280*)	
175	-	-	-	-	-	-	-	-	-	-	-	670*	810*	
												(204*)	(247*)	
200	-	-	-	-	-	-	-	-	-	-	-	590*	710*	
												(180*)	(216*)	

* Indicates single conductor only (not jacketed).

Note:

No asterisk indicates both jacketed cable and single-conductor cables.

- The table is based on copper wire. If aluminum wire is used, multiply lengths by 0.5. The maximum permissible length of aluminum is considerably shorter than the same copper wire size.
- Make sure that the portion of the total cable, which is between the service entrance and a motor starter/controller, does not exceed 25 % of the total maximum length to ensure reliable starter operation. Single-phase control boxes may be connected at any point of the total cable length.
- The table is based on maintaining motor terminal voltage at 95 % of service entrance voltage, running at the maximum value stated on the nameplate.. In general, a voltage drop must be maintained at 3 V/ 100 ft or less.
- 1 foot = 0.305 meter (1 meter = 3.28 feet).

10.4.5 575 V, 3-phase, 60 Hz

		Maximum submersible power cable length (maximum cable length in feet, starter to motor)												
Motor rating	[Hp]	AWG copper wire size												
		14	12	10	8	6	4	3	2	1	0	00	000	0000
575 V 3-ph 60 Hz	0.5	5900 (1798)	9410 (2868)	-	-	-	-	-	-	-	-	-	-	-
	0.75	4270 (1301)	6810 (2076)	-	-	-	-	-	-	-	-	-	-	-
	1	3630 (1106)	5800 (1768)	9120 (2780)	-	-	-	-	-	-	-	-	-	-
	1.5	2620 (799)	4180 (1274)	6580 (2006)	-	-	-	-	-	-	-	-	-	-
	2	2030 (619)	3250 (991)	5110 (1558)	8060 (2457)	-	-	-	-	-	-	-	-	-
	3	1580 (482)	2530 (771)	3980 (1213)	6270 (1911)	-	-	-	-	-	-	-	-	-
	5	920 (280)	1480 (451)	2330 (710)	3680 (1122)	5750 (1753)	-	-	-	-	-	-	-	-
	7.5	660 (201)	1060 (323)	1680 (512)	2650 (808)	4150 (1265)	-	-	-	-	-	-	-	-
	10	490 (149)	780 (238)	1240 (378)	1950 (594)	3060 (933)	4770 (1454)	5940 (1811)	-	-	-	-	-	-
	15	330* (101*)	530 (162)	850 (259)	1340 (408)	2090 (637)	3260 (994)	4060 (1237)	-	-	-	-	-	-
	20	-	410* (125*)	650 (198)	1030 (314)	1610 (491)	2520 (768)	3140 (957)	3860 (1177)	4760 (1451)	5830 (1777)	-	-	-
	25	-	-	520 (158)	830 (253)	1300 (396)	2030 (619)	2530 (771)	3110 (948)	3840 (1170)	4710 (1436)	-	-	-
	30	-	-	430* (131*)	680 (207)	1070 (326)	1670 (509)	2080 (634)	2560 (780)	3160 (963)	3880 (1183)	4770 (1454)	5780 (1762)	7030 (2143)
	40	-	-	-	500* (152*)	790 (241)	1240 (378)	1540 (469)	1900 (579)	2330 (710)	2860 (872)	3510 (1070)	4230 (1289)	5140 (1567)
	50	-	-	-	410* (125*)	640* (195*)	1000 (305)	1250 (381)	1540 (469)	1890 (576)	2310 (704)	2840 (866)	3420 (1042)	4140 (1262)
60	-	-	-	-	540* (165*)	850 (259)	1060 (323)	1300 (396)	1600 (488)	1960 (597)	2400 (732)	2890 (881)	3500 (1067)	
75	-	-	-	-	-	690* (210*)	860 (262)	1060 (323)	1310 (399)	1600 (488)	1970 (600)	2380 (725)	2890 (881)	
100	-	-	-	-	-	-	640* (195*)	790* (241*)	970 (296)	1190 (363)	1460 (445)	1770 (539)	2150 (655)	

125	-	-	-	-	-	-	-	-	630 [*] (192 [*])	770 [*] (235 [*])	950 (290)	1160 (354)	1400 (427)	1690 (515)
150	-	-	-	-	-	-	-	-	660 [*] (202 [*])	800 [*] (244 [*])	990 [*] (302 [*])	1190 (363)	1440 (439)	
175	-	-	-	-	-	-	-	-	-	700 [*] (214 [*])	870 [*] (265 [*])	1050 [*] (320 [*])	1270 (387)	
200	-	-	-	-	-	-	-	-	-	-	760 [*] (232 [*])	920 [*] (280 [*])	1110 [*] (338 [*])	

* Indicates single conductor only (not jacketed).

10.5 Approvals

SP and SPE, all sizes *



NSF_CULUS_WATER_QUALITY_12



TM059757

Pump End Only
MH26400

MS6000C and
MS6000P motor



NSF_CULUS_WATER_QUALITY_12



TM059757

Submersible
Motor
MH26400

MS4000 motor



TM067249

Submersible
Motor
NSF/ANSI 372
MH26400



TM059569

MS402 motor



TM067249

Submersible
Motor
NSF/ANSI 372
MH26400



TM059569



TM050001_0411

* The Grundfos SP/SPE pumps are certified when driven by a certified motor provided with suitable overheating protection.

10.6 Electrical data

10.6.1 Grundfos submersible motors, 60 Hz

Grundfos submersible motors, 60 Hz										
Hp	Ph	Volt [V]	SF	Circuit breaker or fuses		Amperage		Full load		Max. thrust [lbs]
				Std.	Delay	Start [A]	Max. [A]	Eff. [%]	Power factor	
4-inch, single-phase, 2-wire motors (control box not required)										
0.5	1	115	1.60	35	15	55.0	12.0	62	76	900
0.5	1	230	1.60	15	7	34.5	6.0	62	76	900
0.75	1	230	1.50	20	9	40.5	8.4	62	75	900
1	1	230	1.40	25	12	48.4	9.8	63	82	900
1.5	1	230	1.30	35	15	62.0	13.1	64	85	900
4-inch, single-phase, 3-wire motors										
0.5	1	115	1.60	35	15	42.5	12.0	61	76	900
0.5	1	230	1.60	15	7	21.5	6.0	62	76	900
0.75	1	230	1.50	20	9	31.4	8.4	62	75	900
1	1	230	1.40	25	12	37.0	9.8	63	82	900
1.5	1	230	1.30	35	15	45.9	11.6	69	89	900
2	1	230	1.25	35	20	57.0	13.2	72	86	1500
3	1	230	1.15	45	30	77.0	17.0	74	93	1500
5	1	230	1.15	70	45	110.0	27.5	77	92	1500
4-inch, three-phase, 3-wire motors										
1.5	3	230	1.30	15	8	40.3	7.3	75	72	900
1.5	3	460	1.30	10	4	20.1	3.7	75	72	900
1.5	3	575	1.30	10	4	16.1	2.9	75	72	900
2	3	230	1.25	20	10	48	8.7	76	75	900
2	3	460	1.25	10	5	24	4.4	76	75	900
2	3	575	1.25	10	4	19.2	3.5	76	75	900
3	3	230	1.15	30	15	56	12.2	77	75	1500
3	3	460	1.15	15	7	28	6.1	77	75	1500
3	3	575	1.15	15	6	22	4.8	77	75	1500
5	3	230	1.15	40	25	108	19.8	80	82	1500
5	3	460	1.15	20	12	54	9.9	80	82	1500
5	3	575	1.15	15	9	54	7.9	80	82	1500
7.5	3	230	1.15	60	30	130	25.0	81	82	1500
7.5	3	460	1.15	35	15	67	13.2	81	82	1500
7.5	3	575	1.15	30	15	67	10.6	81	82	1500
10	3	460	1.15	50	30	90	18	81	80	1500



Single-phase motors (thermally protected): Use with approved motor control that matches the motor input in full load amperes.



Three-phase motors: Use with approved motor control that matches the motor input in full load amperes

with overload element(s) selected or adjusted according to control instructions.

Grundfos submersible motors, 60 Hz										
Hp	P h	Volt [V]	SF	Circuit breaker or fuses		Amperage		Full load		Max. thrust [lbs]
				Std.	Delay	Start [A]	Max. [A]	Eff. [%]	Power factor	
6-inch, three-phase motors										
7.5	3	208-230	1.15	65	40	114-130	23.4 - 27.5	81	85-84	6070
7.5	3	460	1.15	30	17	68	13.2	81	85	6070
7.5	3	575	1.15	30	17	51	10.2	81	85	6070
10	3	208-230	1.15	90	50	126-142	30.0 - 37.5	82	86-84	6070
10	3	460	1.15	40	25	75	17.4	82	85	6070
10	3	575	1.15	40	25	56.5	13.4	82	85	6070
15	3	208-230	1.15	130	75	198-224	44.5 - 53.5	83	86-84	6070
15	3	460	1.15	60	35	112	25	83	84	6070
15	3	575	1.15	60	35	84	19.4	83	84	6070
20	3	208-230	1.15	175	100	310-350	57.5 - 71.5	84	86-84	6070
20	3	460	1.15	80	45	186	33.5	84	84	6070
20	3	575	1.15	80	45	144	26	84	84	6070
25	3	208-230	1.15	200	125	395-445	71-87	84	87-84	6070
25	3	460	1.15	100	60	236	41	84	84	6070
25	3	575	1.15	100	60	180	32	84	84	6070
30	3	208-230	1.15	250	150	445-500	81-104	84	87-84	6070
30	3	460	1.15	125	70	265	48	85	85	6070
30	3	575	1.15	125	70	194	37	85	85	6070
40	3	460	1.15	170	90	330	65	85	84	6070
40	3	575	1.15	170	90	250	49.5	85	84	6070
50	3	460	1.15	225	125	405	73.0	83	83	6182
8-inch, three-phase motors										
40	3	460	1.15	175	100	380	55.7	83	85	13000
50	3	460	1.15	225	125	550	67.8	84	85	13000
60	3	460	1.15	250	150	640	80.4	86	85	13000
75	3	460	1.15	300	175	580	97.4	86	86	13000
100	3	460	1.15	400	225	570	130.4	87	86	13000
125	3	460	1.15	500	300	600	160.0	87	87	13000
150	3	460	1.15	600	350	580	191.3	86	87	13000
10-inch, three-phase motors										
175	3	460	1.15	700	400	570	230.4	88	85	13000
200	3	460	1.15	800	500	620	265.2	87	82	13000
250	3	460	1.15	1100	600	610	352.2	87	79	13000

Grundfos submersible permanent-magnet motors, 60 Hz

Hp	Ph	Volt [V]	SF	Amperage		Eff. [%]	Full load	Max. thrust [lbs]
				Start [A]	Max. [A]		Power factor	
6-inch, three-phase permanent-magnet motors								
5	3	410	1.15	8.8	8.8	87.2	96	6070
7.5	3	410	1.15	12.4	12.4	89.4	92	6070
10	3	410	1.15	16.2	16.2	90.1	88	6070
15	3	410	1.15	24.5	24.5	92.4	94	6070
20	3	410	1.15	32.2	32.2	92.8	90	6070
25	3	410	1.15	39.0	39.0	93.0	88	6070
30	3	410	1.15	44.8	44.8	93.0	92	6070
40	3	410	1.15	60.0	60.0	93.0	91	6070
50	3	410	1.15	82.6	82.6	92.5	86	6070

CUE 3 x 380 - 480V, UL compliant, maximum recommended fuzes

Motor power [hp]	CUE 3 x 380 - 500V Nema 4x outdoor	CUE 3 x 380 - 500 V Nema 1 indoor	Bussmann Type RK1	Bussmann Type J	Bussmann Type T	SIBA Type RK1	Littelfuse Type RK1
5	99619042	99616714	KTS-R-20	JKS-20	JJS-20	5017906-020	KLN-R-20
7.5	99619043	99616715	KTS-R-25	JKS-25	JJS-25	5017906-025	KLN-R-25
10	99619044	99616716	KTS-R-30	JKS-30	JJS-30	5012406-032	KLN-R-30
15	99619045	99616717	KTS-R-40	JKS-40	JJS-40	5014006-040	KLS-R-40
20	99619046	99616718	KTS-R-50	JKS-50	JJS-50	5014006-050	KLN-R-50
25	99619047	99616719	KTS-R-50	JKS-50	JJS-50	5014006-050	KLN-R-50
30	99619048	99616720	KTS-R-60	JKS-60	JJS-60	5014006-063	KLN-R-60
40	99619049	99616721	KTS-R-80	JKS-80	JJS-80	2028220-120	KLN-R-80
50	99619051	99616723	KTS-R-100	JKS-100	JJS-100	2028220-125	KLN-R-100

CUE 3 x 380-480V, UL compliant, maximum recommended fuzes

Motor power [hp]	CUE 3 x 380 - 500V Nema 4x outdoor	CUE 3 x 380 - 500 V Nema 1 indoor	Ferraz-Shawmut Type CC	Ferraz-Shawmut Type RK1	Bussmann Type JFHR2	Ferraz-Shawmut J
5	99619042	99616714	ATM-R-20	A6K-20-R	FWH-20	HSJ-20
7.5	99619043	99616715	ATM-R-25	A6K-25-R	FWH-25	HSJ-25
10	99619044	99616716	ATM-R-30	A6K-30-R	FWH-30	HSJ-30
15	99619045	99616717	-	A6K-40-R	FWH-40	
20	99619046	99616718	-	A6K-50-R	FWH-50	HSJ-50

25	99619047	99616719	-	A6K-50-R	FWH-50	HSJ-50
30	99619048	99616720	-	A6K-60-R	FWH-60	HSJ-60
40	99619049	99616721	-	A6K-80-R	FWH-80	HSJ-80
50	99619051	99616723	-	A6K-100-R	FWH-100	HSJ-100

10.6.2 Other motor manufacturers

Refer to the other motor manufacturers' application maintenance manual.

10.6.3 Correcting for three-phase current imbalance

Example: Check for current imbalance for a 230 V, three-phase, 60 Hz submersible motor, 18.6 full load amps.

Solution: Steps 1 to 3 measure and record amps on each submersible drop cable lead for hookups 1, 2 and 3.

Observe that hookup 3 must be used since it shows the least amount of current imbalance. Therefore, the motor operates at maximum efficiency and reliability.

By comparing the current values recorded on each leg, it can be noted that the highest value is always on the same leg, L₃. This indicates the imbalance is in the power source. If the high current values are on a different leg each time the leads are changed, the imbalance would be caused by the motor or a poor connection.

If the current imbalance is greater than 5 %, contact the power supply company for.

For a detailed explanation of three-phase balance procedures, see section Check for current imbalance.

	Step 1 (hookup 1)	Step 2 (hookup 2)	Step 3 (hookup 3)
(T ₁)	DL ₁ = 25.5 amps	DL ₃ = 25 amps	DL ₂ = 25.0 amps
(T ₂)	DL ₂ = 23.0 amps	DL ₁ = 24 amps	DL ₃ = 24.5 amps
(T ₃)	DL ₃ = 26.5 amps	DL ₂ = 26 amps	DL ₁ = 25.5 amps
Step 4	Total = 75 amps	Total = 75 amps	Total = 75 amps

Step 5	Average current = $\frac{\text{total current}}{3 \text{ readings}} = \frac{75}{3} = 25 \text{ amps}$
--------	--

Step 6	Greatest amp difference from the average:	(hookup 1) = 25 - 23 = 2 (hookup 2) = 26 - 25 = 1 (hookup 3) = 25.5 - 25 = 0.5
--------	---	--

Step 7	% imbalance	(hookup 1) = 2/25 x 100 = 8 (hookup 2) = 1/25 x 100 = 4 (hookup 3) = 0.5/25 x 100 = 2
--------	-------------	---

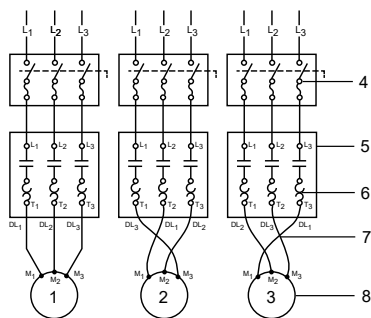

TM0600042

Pos.	Description
1	Hookup 1
2	Hookup 2
3	Hookup 3
4	Fused disconnect switch
5	Magnetic starter
6	Manual reset of thermal overload with extra quick trip heaters
7	Submersible drop cable
8	Motor

Correcting for three-phase current imbalance

Related information

[7.1.2 Check for current imbalance](#)

11. Disposing of the product

This product or parts of it must be disposed of in an environmentally sound way.

1. Use the public or private waste collection service.
2. If this is not possible, contact the nearest Grundfos company or service workshop.



The crossed-out wheellie bin symbol on a product means that it must be disposed of separately from household waste. When a product marked with this symbol reaches its end of life, take it to a collection point designated by the local waste disposal authorities. The separate collection and recycling of such products will help protect the environment and human health.

See also end-of-life information at www.grundfos.com/product-recycling.

Appendix A

A.1. Appendix

Removing and fitting of cable guard

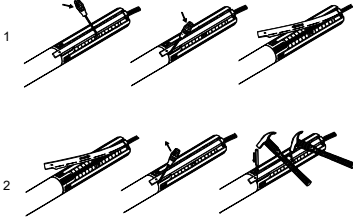

TM001323

Removing and fitting of cable guard for SP 5S, 7S, 10S, 16S, and 25S (smooth shaft)

Pos.	Description
1	Removing cable guard
2	Fitting cable guard

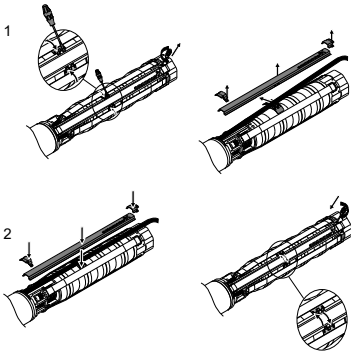

TM060693

Removing and fitting of cable guard for SP 35S, 45S, 62S, 77S, 150S, 230S, and 300S

Pos.	Description
1	Removing cable guard
2	Fitting cable guard

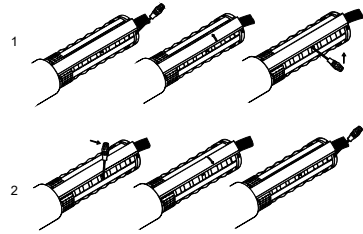

TM001326

Removing and fitting of cable guard for SP 385S, 475S, 625S, 800S, and 1100S

Pos.	Description
1	Removing cable guard
2	Fitting cable guard

A.2. Annexe

Dépose et fixation du protège-câble

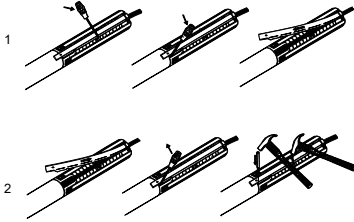

TM001323

Dépose et fixation du protège-câble pour SP 5S, 7S, 10S, 16S, et 25S (arbre lisse)

Pos.	Description
1	Dépose du protège-câble
2	Fixation du protège-câble

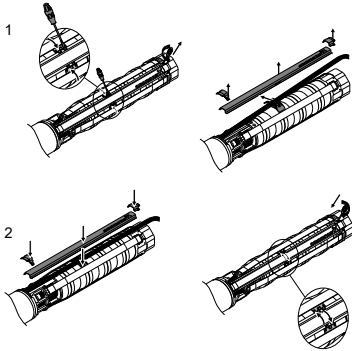

TM060693

Dépose et fixation du protège-câble pour SP 35S, 45S, 62S, 77S, 150S, 230S, et 300S

Pos.	Description
1	Dépose du protège-câble
2	Fixation du protège-câble

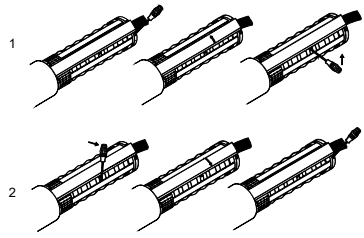

TM001326

Dépose et fixation du protège-câble pour SP 385S, 475S, 625S, 800S, et 1100S

Pos.	Description
1	Dépose du protège-câble
2	Fixation du protège-câble

A.3. Apéndice

Desmontaje e instalación del protector de cable

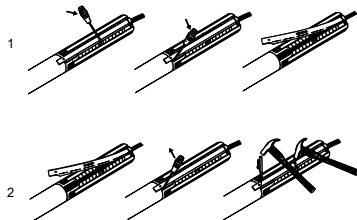

TM001323

Desmontaje e instalación de la cubierta del cable para bombas SP 5S, 7S, 10S, 16S y 25S (eje flexible)

Pos.	Descripción
1	Desmontaje de la cubierta del cable
2	Instalación de la cubierta del cable

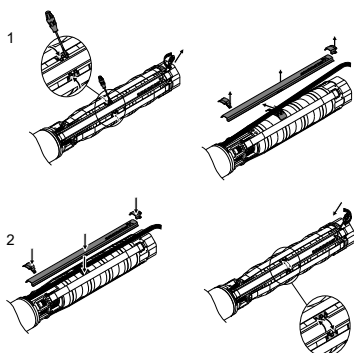

TM006093

Desmontaje e instalación de la cubierta del cable para bombas SP 35S, 45S, 62S, 77S, 150S, 230S y 300S

Pos.	Descripción
1	Desmontaje de la cubierta del cable
2	Instalación de la cubierta del cable

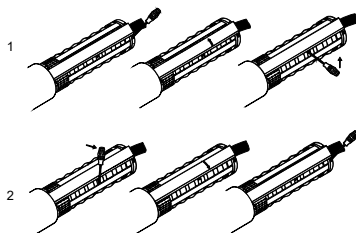

TM001326

Desmontaje e instalación de la cubierta del cable para bombas SP 385S, 475S, 625S, 800S y 1100S

Pos.	Descripción
1	Desmontaje de la cubierta del cable
2	Instalación de la cubierta del cable

Argentina

Bombas GRUNDFOS de Argentina
S.A.
Ruta Panamericana km.
37.500industin
1619 - Garín Pcia. de B.A.
Tel.: +54-3327 414 444
Fax: +54-3327 45 3190

Australia

GRUNDFOS Pumps Pty. Ltd.
P.O. Box 2040
Regency Park
South Australia 5942
Tel.: +61-8-8461-4611
Fax: +61-8-8340-0155

Austria

GRUNDFOS Pumpen Vertrieb
Ges.m.b.H.
Grundfosstraße 2
A-5082 Grödig/Salzburg
Tel.: +43-6246-883-0
Fax: +43-6246-883-30

Belgium

N.V. GRUNDFOS Bellux S.A.
Boomsesteenweg 81-83
B-2630 Aartselaar
Tel.: +32-3-870 7300
Fax: +32-3-870 7301

Belarus

Представительство ГРУНДФОС в
Минске
220125, Минск
ул. Шафарнянская, 11, оф. 56, БЦ
«Порт»
Тел.: +375 17 397 397 3
+375 17 397 397 4
Факс: +375 17 397 397 1
E-mail: minsk@grundfos.com

Bosnia and Herzegovina

GRUNDFOS Sarajevo
Zmaj od Bosne 7-7A
BiH-71000 Sarajevo
Tel.: +387 33 592 480
Fax: +387 33 590 465
www.ba.grundfos.com
E-mail: grundfos@bih.net.ba

Brazil

BOMBAS GRUNDFOS DO BRASIL
Av. Humberto de Alencar Castelo
Branco, 630
CEP 09850 - 300
São Bernardo do Campo - SP
Tel.: +55-11 4393 5533
Fax: +55-11 4343 5015

Bulgaria

Grundfos Bulgaria EOOD
Slatina District
Iztocna Tangenta street no. 100
BG - 1592 Sofia
Tel.: +359 2 49 22 200
Fax: +359 2 49 22 201
E-mail: bulgaria@grundfos.bg

Canada

GRUNDFOS Canada inc.
2941 Brighton Road
Oakville, Ontario
L6H 6C9
Tel.: +1-905 829 9533
Fax: +1-905 829 9512

China

GRUNDFOS Pumps (Shanghai) Co.
Ltd.
10F The Hub, No. 33 Suhong Road
Minhang District
Shanghai 201106 PRC
Tel.: +86 21 612 252 22
Fax: +86 21 612 253 33

Columbia

GRUNDFOS Colombia S.A.S.
Km 1.5 via Siberia-Cota Conj. Potrero
Chico,
Parque Empresarial Arcos de Cota
Bod. 1A.
Cota, Cundinamarca
Tel.: +57(1)-2913444
Fax: +57(1)-8764586

Croatia

GRUNDFOS CROATIA d.o.o.
Buzinski prilaz 38, Buzin
HR-10010 Zagreb
Tel.: +385 1 6595 400
Fax: +385 1 6595 499
www.hr.grundfos.com

Czech Republic

GRUNDFOS Sales Czechia and
Slovakia s.r.o.
Čajkovského 21
779 00 Olomouc
Tel.: +420-585-716 111

Denmark

GRUNDFOS DK A/S
Martin Bachs Vej 3
DK-8850 Bjerringbro
Tel.: +45-87 50 50 50
Fax: +45-87 50 51 51
E-mail: info_GDK@grundfos.com
www.grundfos.com/DK

Estonia

GRUNDFOS Pumps Eesti OÜ
Peterburi tee 92G
11415 Tallinn
Tel.: + 372 606 1690
Fax: + 372 606 1691

Finland

OY GRUNDFOS Pumput AB
Trukkikuja 1
FI-01360 Vantaa
Tel.: +358-(0) 207 889 500

France

Pompes GRUNDFOS Distribution S.A.
Parc d'Activités de Chesnes
57, rue de Malacombe
F-38290 St. Quentin Fallavier (Lyon)
Tel.: +33-4 74 82 15 15
Fax: +33-4 74 94 10 51

Germany

GRUNDFOS GMBH
Schlüterstr. 33
40699 Erkrath
Tel.: +49-(0) 211 929 69-0
Fax: +49-(0) 211 929 69-3799
E-mail: infoservice@grundfos.de
Service in Deutschland:
kundendienst@grundfos.de

Greece

GRUNDFOS Hellas A.E.B.E.
20th km. Athinon-Markopoulou Av.
P.O. Box 71
GR-19002 Peania
Tel.: +0030-210-66 83 400
Fax: +0030-210-66 46 273

Hong Kong

GRUNDFOS Pumps (Hong Kong) Ltd.
Unit 1, Ground floor, Siu Wai industrial
Centre
29-33 Wing Hong Street & 68 King
Lam Street, Cheung Sha Wan
Kowloon
Tel.: +852-27861706 / 27861741
Fax: +852-27858664

Hungary

GRUNDFOS Hungária Kft.
Tópark u. 8
H-2045 Törökbálint
Tel.: +36-23 511 110
Fax: +36-23 511 111

India

GRUNDFOS Pumps india Private
Limited
118 Old Mahabalipuram Road
Thoraiakkam
Chennai 600 097
Tel.: +91-44 2496 6800

Indonesia

PT GRUNDFOS Pompa
Graha intirub Lt. 2 & 3
Jln. Cillitan Besar No.454. Makasar,
Jakarta Timur
ID-Jakarta 13650
Tel.: +62 21-469-51900
Fax: +62 21-460 6910 / 460 6901

Ireland

GRUNDFOS (Ireland) Ltd.
Unit A, Merrywell Business Park
Ballymount Road Lower
Dublin 12
Tel.: +353-1-4089 800
Fax: +353-1-4089 830

Italy

GRUNDFOS Pompe Italia S.r.l.
Via Gran Sasso 4
I-20060 Truccazzano (Milano)
Tel.: +39-02-95838112
Fax: +39-02-95309290 / 95838461

Japan

GRUNDFOS Pumps K.K.
1-2-3, Shin-Miyakoda, Kita-ku
Hamamatsu
431-2103 Japan
Tel.: +81 53 428 4760
Fax: +81 53 428 5005

Korea

GRUNDFOS Pumps Korea Ltd.
6th Floor, Aju Building 679-5
Yeoksam-dong, Kangnam-ku, 135-916
Seoul, Korea
Tel.: +82-2-5317 600
Fax: +82-2-5633 725

Latvia

SIA GRUNDFOS Pumps Latvia
Deglava biznesa centrs
Augusta Deglava ielā 60
LV-1035, Rīga,
Tel.: + 371 714 9640, 7 149 641
Fax: + 371 914 9646

Lithuania

GRUNDFOS Pumps UAB
Smolensko g. 6
LT-03201 Vilnius
Tel.: + 370 52 395 430
Fax: + 370 52 395 431

Malaysia

GRUNDFOS Pumps Sdn. Bhd.
7 Jalan Peguam U1/25
Glenmarie Industrial Park
40150 Shah Alam, Selangor
Tel.: +60-3-5569 2922
Fax: +60-3-5569 2866

Mexico

Bombas GRUNDFOS de México
S.A. de C.V.
Boulevard TLC No. 15
Parque Industrial Stiva Aeropuerto
Apodaca, N.L. 66600
Tel.: +52-81-8144 4000
Fax: +52-81-8144 4010

Netherlands

GRUNDFOS Netherlands
Veluwezoom 35
1326 AE Almere
Postbus 22015
1302 CA ALMERE
Tel.: +31-88-478 6336
Fax: +31-88-478 6332
E-mail: info_gnl@grundfos.com

New Zealand

GRUNDFOS Pumps NZ Ltd.
17 Beatrice Tinsley Crescent
North Harbour Industrial Estate
Albany, Auckland
Tel.: +64-9-415 3240
Fax: +64-9-415 3250

Norway

GRUNDFOS Pumper A/S
Strømsveien 344
Postboks 235, Leirdal
N-1011 Oslo
Tel.: +47-22 90 47 00
Fax: +47-22 32 21 50

Poland

GRUNDFOS Pompy Sp. z o.o.
ul. Klonowa 23
Baranowo k. Poznania
PL-62-081 Przeźmierowo
Tel.: (+48-61) 650 13 00
Fax: (+48-61) 650 13 50

Portugal

Bombas GRUNDFOS Portugal, S.A.
Rua Calvet de Magalhães, 241
Apartado 1079
P-2770-153 Paço de Arcos
Tel.: +351-21-440 76 00
Fax: +351-21-440 76 90

Romania

GRUNDFOS Pompe România SRL
S-PARK BUSINESS CENTER,
Clădirea A2, etaj 2
Str. Tipografilor, Nr. 11-15, Sector
1, Cod 013714
Bucuresti, Romania
Tel.: 004 021 2004 100
E-mail: romania@grundfos.ro

Russia

ООО Грундфос Россия
ул. Школьная, 39-41
Москва, RU-109544, Russia
Тел. (+7) 495 564-88-00 (495)
737-30-00
Факс (+7) 495 564 8811
E-mail
grundfos.moscow@grundfos.com

Serbia

Grundfos Srbija d.o.o.
Omladinskih brigada 90b
11070 Novi Beograd
Tel.: +381 11 2258 740
Fax: +381 11 2281 769
www.rs.grundfos.com

Singapore

GRUNDFOS (Singapore) Pte. Ltd.
25 Jalan Tukang
Singapore 619264
Tel.: +65-6681 9688
Fax: +65-6681 9689

Slovakia

GRUNDFOS s.r.o.
Prievozská 4D 821 09 BRATISLAVA
Tel.: +421 2 5020 1426
sk.grundfos.com

Slovenia

GRUNDFOS LJUBLJANA, d.o.o.
Leskoškova 9e, 1122 Ljubljana
Tel.: +386 (0) 1 568 06 10
Fax: +386 (0) 1 568 06 19
E-mail: tehniko-si@grundfos.com

South Africa

GRUNDFOS (PTY) LTD
16 Lascelles Drive, Meadowbrook
Estate
1609 Germiston, Johannesburg
Tel.: (+27) 10 248 6000
Fax: (+27) 10 248 6002
E-mail: lgradidge@grundfos.com

Spain

Bombas GRUNDFOS España S.A.
Camino de la Fuentecilla, s/n
E-28110 Algete (Madrid)
Tel.: +34-91-848 8800
Fax: +34-91-628 0465

Sweden

GRUNDFOS AB
Box 333 (Lunnagårdsgatan 6)
431 24 Mölndal
Tel.: +46 31 332 23 000
Fax: +46 31 331 94 60

Switzerland

GRUNDFOS Pumpen AG
Bruggacherstrasse 10
CH-8117 Fällanden/ZH
Tel.: +41-44-806 8111
Fax: +41-44-806 8115

Taiwan

GRUNDFOS Pumps (Taiwan) Ltd.
7 Floor, 219 Min-Chuan Road
Taichung, Taiwan, R.O.C.
Tel.: +886-4-2305 0868
Fax: +886-4-2305 0878

Thailand

GRUNDFOS (Thailand) Ltd.
92 Chaloen Phrakiat Rama 9 Road
Dokmai, Pravej, Bangkok 10250
Tel.: +66-2-725 8999
Fax: +66-2-725 8998

Turkey

GRUNDFOS POMPA San. ve Tic. Ltd.
Sti.
Gebze Organize Sanayi Bölgesi
İhsan dede Caddesi
2. yol 200. Sokak No. 204
41490 Gebze/ Kocaeli
Tel.: +90 - 262-679 7979
Fax: +90 - 262-679 7905
E-mail: satis@grundfos.com

Ukraine

ТОВ "ГРУНДФОС УКРАЇНА"
Бізнес Центр Європа
Столичне шосе, 103
м. Київ, 03131, Україна
Tel.: (+38 044) 237 04 00
Fax: (+38 044) 237 04 01
E-mail: ukraine@grundfos.com

United Arab Emirates

GRUNDFOS Gulf Distribution
P.O. Box 16768
Jebel Ali Free Zone, Dubai
Tel.: +971 4 8815 166
Fax: +971 4 8815 136

United Kingdom

GRUNDFOS Pumps Ltd.
Grovebury Road
Leighton Buzzard/Beds. LU7 4TL
Tel.: +44-1525-850000
Fax: +44-1525-850011

U.S.A.

Global Headquarters for WU
856 Koomey Road
Brookshire, Texas 77423 USA
Phone: +1-630-236-5500

Uzbekistan

Grundfos Tashkent, Uzbekistan
The Representative Office of Grundfos
Kazakhstan in Uzbekistan
38a, Oybek street, Tashkent
Tel.: (+998) 71 150 3290 / 71 150
3291
Fax: (+998) 71 150 3292

98559518 11.2022

ECM: 1354681

www.grundfos.com

GRUNDFOS 

Trademarks displayed in this material, including but not limited to Grundfos and the Grundfos logo, are registered trademarks owned by The Grundfos Group. © 2022 Grundfos Holding AS, all rights reserved.