

## T31 Series Regenerative Turbine Pumps



- Capacities to 10 GPM
- Heads to 300 Feet
- Temperatures to 230°F
- Close Coupled & Long Coupled Configurations



MTH PUMPS

# T31 Series Regenerative Turbine Pumps

## MTH T31 Series

The T31 Series close-coupled regenerative turbine pumps represent the most economical, high performance alternative for low flow (1/2 to 10 GPM) applications involving moderate to high pressures (heads to 300 feet). By combining the latest concepts in hydraulic turbine pump design with precision computer controlled manufacturing, the T31 Series pumps deliver high efficiency pumping operation, even at low NPSH. Maintenance costs are kept to a minimum by combining an easily serviceable design with the use of high quality components to provide long life.

## Water Passage Design

MTH masters one of the most critical design considerations of regenerative turbine pumps - the shaping of water passageways to achieve maximum capacity and pressure while minimizing horsepower requirements. By optimizing water passageway cross-sectional profiles for each impeller, MTH improves both efficiency and pressure over the standards realized by other techniques.

## Impeller Profile

One of the most notable improvements in regenerative turbine pump technology, incorporated in T31 Series pumps, involves the ability to determine the optimum impeller width and blade length. These factors have a significant effect on the required horsepower versus pressure curve for regenerative turbine pumps.

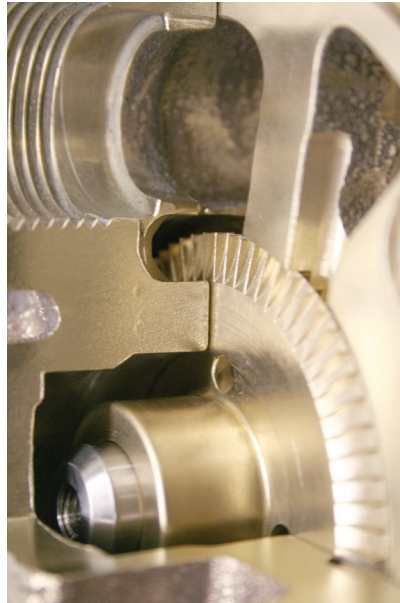

By optimizing these parameters for each pump, peak efficiency is improved and "off peak" horsepower requirements are reduced as well.

## Impeller Blades

After the most favorable impeller profile has been determined for a particular water passageway cross-section, MTH calculates the number of blades needed to maximize the performance of that pump. Current blade design in the T31 Series increases both efficiency and design pressure without the manufacturing difficulties associated with producing contoured blade impellers. State-of-the-art computer controlled machines simplify manufacturing of the various MTH impellers utilized in the T31 Series. The result is a high per-

formance pump providing efficiency characteristics exceeding those of much more expensive units.

## NPSH Requirements

T31 Series regenerative turbine pumps meet low net positive suction head (NPSH) requirements without efficiency loss. This is achieved by keeping the inlet fluid velocity low and then gently accelerating to passageway velocities. Special ramps are responsible for this gentle fluid entry into the impeller blades and account for the high inlet efficiency of the T31 Series pumps.

## Steep Head/Capacity Curve

Pumping capacity varies only slightly as pressure changes. Steep pressure characteristic overcomes temporary line resistances.

## Self Adjusting Impeller

T31 impellers utilize balancing holes to promote hydraulic self-centering and to eliminate the need for external adjustment. The impeller exerts no thrust load on the bearings, thereby extending service life. Self-centering is equally effective whether mounted in the horizontal or vertical position.

## Extended Reliability Motors

Custom manufactured D3 motors feature a 304 stainless steel shaft and heavy duty ball bearing for extended life. Single phase ODP and 3 phase TEFC enclosures are standard, as well as a two-pole, 50Hz/60Hz ratings, and UL and CE Marks.

## STANDARD MATERIALS

PART	ALL BRONZE	STAINLESS STEEL
Motor Bracket	Bronze	Stainless Steel AISI 316
Cover	Bronze	Stainless Steel AISI 316
Impeller	Bronze	W88 ASTM A494
"O" Rings	Buna N	Viton A
Seals	Buna/Carbon	Viton/Carbon
Seats	Buna/Ceramic	Viton/Ceramic
Shaft	Stainless Steel AISI 304	Stainless Steel AISI 304

## LIMITATIONS

Discharge Pressure	300 PSI
Seal Pressure*	200 PSI
Suction Pressure (Min.)	26" Hg Vac.
Speed** (Max.)	5500 RPM
<b>Temperature</b>	
Standard Construction	-20° F
Ceramic Seal Seat - Water	+230° F
Ni-Resist Seal Seat - Water	+230° F

## Horsepower

D3 - 1 Phase	2 HP
D3 - 3 Phase	3 HP

\*Suction pressure plus 50 percent of differential pressure

\*\*With variable frequency drive @ 90Hz

## T31 SERIES

# Design Features

### Mechanical Seals

All bronze pumps have Buna elastomers, high temperature carbon seals and ceramic seats, while Stainless Steel pumps feature Viton elastomers, carbon seals, and ceramic seats. Optional seats and materials are available.

### 300 PSI Case Working Pressure

Rigid structure is designed for maximum casing strength.

### Water Flinger

A water flinger provides added protection to ball bearings in the event of seal leakage.

### End Suction/Top Discharge

T31 Series pumps are compact to allow installation in small areas. The discharge can be rotated to 90°, 180°, 270° positions to facilitate the most convenient installation.

### Simple Construction

T31 Series pumps contain only three major components, allowing for easy service.

### Best Efficiency

New pump designs optimize efficiency for each size.

### Non-Cavitating

T31 Series pumps may be operated under adverse inlet conditions without audible or measurable cavitation.

### Low NPSH

Special inlet design provides superior fluid handling ability with low head inlet conditions.

### 100% Tested

Every pump is fully tested to verify performance prior to shipment.

### Volatile Fluid Handling

The turbine impeller handles vapors in excess of 20% by volume, minimizing the possibility of vapor lock.

### “O” Ring Gaskets

“O” ring gaskets are used throughout the T31 Series pumps to assure positive sealing.

### Extended Reliability Motors

T31 Series pumps utilize our custom manufactured D3 motors that incorporate a 304 stainless steel shaft and an upgraded heavy-duty bearing. All D3 motors are 2-pole, 50/60Hz rated and feature UL and CE marks for Worldwide use. Single phase units are available from 1/2 to 2HP in an ODP enclosure, while three-phase units are available up to 3HP, and come in an upgraded TEFC enclosure.

## Dimensions

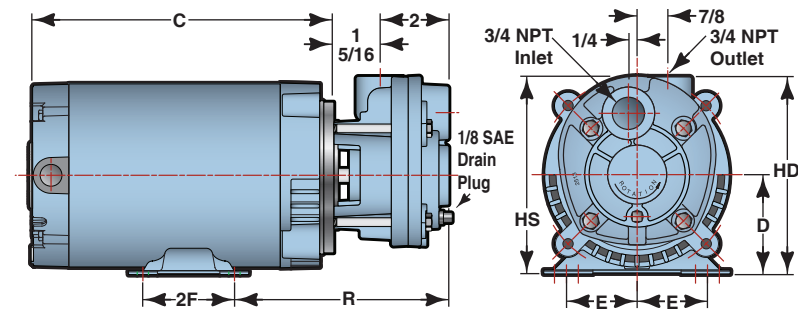

T31 Series Single Phase ODP

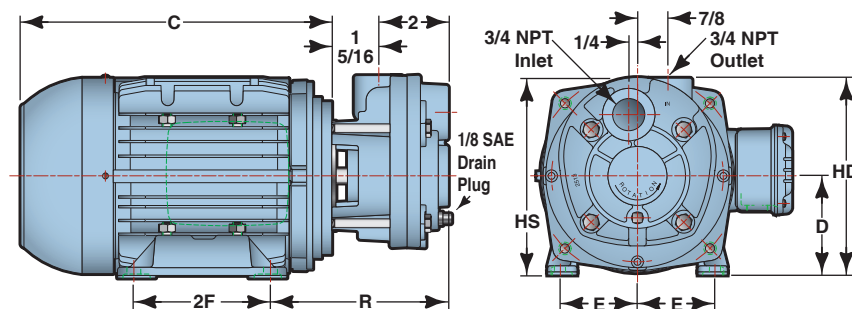

T31 Series Three Phase TEFC

## Optional Features

### Construction Materials

T31 Series pumps are available in all bronze and 316 stainless steel. Consult the factory for other materials, including RoHS compliant materials.

### Bearing Pedestals

All models can be pedestal mounted with flexible-coupled drive.

### Sealless Canned Version

For critical and difficult to seal applications, see the ST31 Series.

### Variable Frequency Drive

VFD and pressure transducer provides closed-loop pressure control and extended service range.

### Inlet Strainer

A 90° suction strainer with a replaceable stainless steel screen is available for installation in the suction line to aid in preventing foreign material from entering the pump. A cap at the bottom of the strainer can be easily and quickly removed for screen cleaning or replacement.

### 56C-Face Adapter

Using the 56 C-face adapter allows close coupling of T31 pumps to special configuration or special enclosure motors providing a smaller footprint and better alignment.

HP	Phase	Enclosure	C	D	E	R	2F	HS	HD
1/3	Single	ODP	9 1/4	3	2 1/8	6 3/8	2 3/4	4 3/4	5 13/16
1/2	Single	ODP	10 1/4	3	2 1/8	6 3/8	2 3/4	4 3/4	5 13/16
3/4 & 1	Single	ODP	10 3/4	3	2 1/8	6 3/8	2 3/4	4 3/4	5 13/16
1 1/2	Single	ODP	11 1/4	3 1/2	2 1/8	6 3/8	2 3/4	4 3/4	5 13/16
1/3 ~ 1	Three	TEF	8 13/16	2 13/16	2 3/16	5 5/16	3 9/16	4 9/16	5 9/16
1 1/2	Three	TEF	9 5/8	3 1/8	2 1/2	5 1/2	3 15/16	4 7/8	5 15/16

# Performance Curves

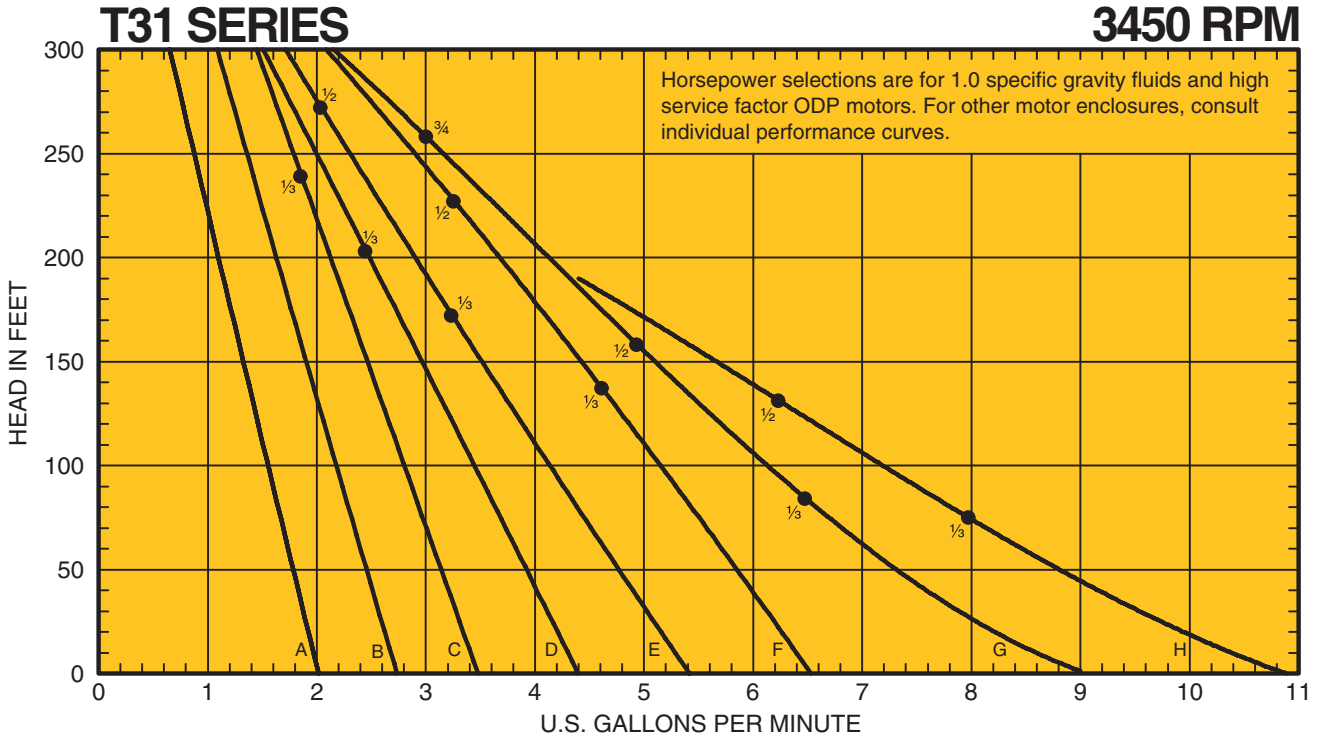

# Engineering Specification

## Horizontal Closed Coupled

The contractor shall furnish (and install as shown on the plans) an MTH T31 Series horizontal close coupled regenerative turbine type pump model \_\_\_\_\_ size 3/4 by 3/4 of (ALL BRONZE) (316 STAINLESS STEEL) construction. Each pump shall have a capacity of \_\_\_\_\_ GPM when operating at a total head of \_\_\_\_\_ feet. Suction pressure will be \_\_\_\_\_ feet with a liquid temperature of \_\_\_\_\_ °F.

The pump is to be furnished with a mechanical seal with stainless steel metal parts, \_\_\_\_\_ elastomers, ceramic seat and carbon washer.

The pump casing shall be vertically split, two piece design, end suction and (top discharge) (90° discharge) (180° discharge) (270° discharge) with water passageways in each piece. The impeller shall be hydraulically self-centering and no external adjustment shall be necessary.

The pump shall be close-coupled to a \_\_\_\_\_ HP \_\_\_\_\_ Phase \_\_\_\_\_ Hertz \_\_\_\_\_ Volt \_\_\_\_\_ RPM horizontal (open drip proof) (totally enclosed) motor, with 304SS shaft, 204 ball bearing and CE Mark. The motor shall be sized to prevent overloading at the highest head condition listed in the specifications.

## Horizontal Pedestal Mount

The contractor shall furnish (and install as shown on the plans) an MTH T31 Series horizontal pedestal mount regenerative turbine type pump model \_\_\_\_\_ size 3/4 by 3/4 of (ALL BRONZE) (316 STAINLESS STEEL) construction. Each pump shall have a capacity of \_\_\_\_\_ GPM when operating at a total head of \_\_\_\_\_ feet. Each pump shall have the capacity of \_\_\_\_\_ GPM when operating at a total head of \_\_\_\_\_ feet. Suction pressure will be \_\_\_\_\_ feet with a liquid temperature of \_\_\_\_\_ °F.

The pump is to be furnished with a mechanical seal with stainless steel metal parts, \_\_\_\_\_ elastomers, ceramic seat and carbon washer.

The pump casing shall be a vertically split two piece design, end suction and (top discharge) (90° discharge) (270° discharge) with water passageways in each piece. The impeller shall be hydraulically self-centering and no external adjustment shall be necessary.

The pump shall be mounted on a bearing pedestal with sealed, grease lubricated ball bearings having a two year minimum design life under maximum pump differential pressure of 300 PSI.

Pump and motor shall be mounted on a common steel baseplate (with cast iron drip pan). The pump is to be flexible-coupled with aluminum coupling guard to a NEMA standard \_\_\_\_\_ HP \_\_\_\_\_ Phase \_\_\_\_\_ Hertz \_\_\_\_\_ Volt \_\_\_\_\_ RPM horizontal (open drip proof) (totally enclosed) (explosion proof) motor. The motor shall be sized to prevent overloading at the highest head condition listed in the specifications. Coupling alignment shall be checked after installation.



**Manufacturing MTH Pumps  
in the USA for 50 years.**

**ISO Registered Company**



**MTH PUMPS**

401 West Main Street • Plano, IL 60545-1436  
Phone: 630-552-4115 • Fax: 630-552-3688  
Email: SALES@MTHPUMPS.COM  
http://WWW.MTHPUMPS.COM



30% TOTAL RECOVERED FIBER  
TOTALLY CHLORINE FREE

PRINTED ON FSC CERTIFIED PAPER