

STA-RITE® ProJet™ HL Series

Cast iron self-priming convertible jet pumps

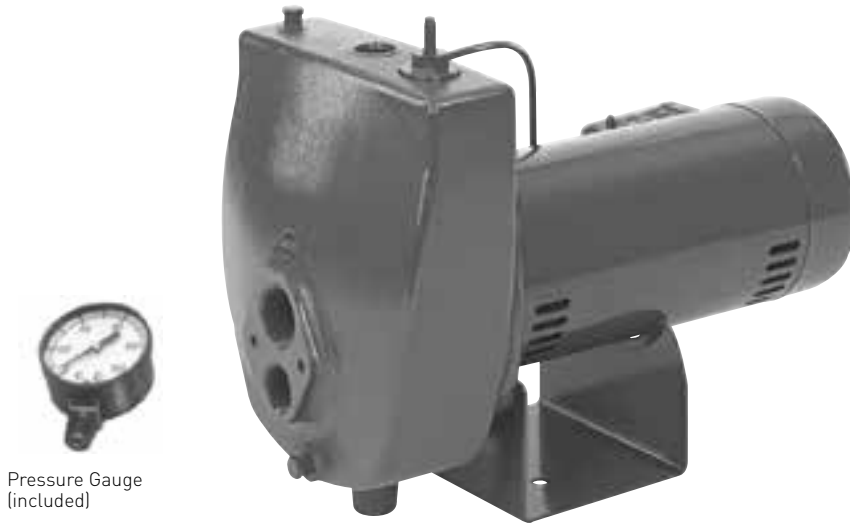

Pressure Gauge (included)



The ProJet HL convertible jet pumps offer a proven cast iron self-priming design available in 1/2 – 1 HP models. The ProJet HL convertible jets utilize built-in regulators offering easier priming and better range of performance from a complete line of shallow well, 4" double pipe, 2" and 3" single pipe jet packages.

APPLICATIONS

Water systems and sprinkling... for homes, farms and cottages.

SPECIFICATIONS

Body and Seal Plate: Close-grained cast iron

Impeller: High-strength Noryl®

Diffuser: Reinforced polypropylene with brass wear ring

Shaft: One-piece threaded 416 stainless steel

Base: Steel, 12 gauge

Max. Liquid Temperature: 140°F

Max. Inlet Pressure: 50 PSI

Pressure Switch Pre-Set: 30-50 PSI

Suction Ports: "Suction-over-Drive"

Pressure Gauge: 0-100 PSI

FEATURES

Quality Construction: Close-grained cast iron pump body is a rugged one-piece unit, specially treated to resist corrosion. Drain port provided for easy winterizing.

Noryl Impeller: Precision-molded for perfect balance...ultra-smooth for highest performance and efficiency.

Precision-Molded Diffuser: Pump primes faster, handles more air, with multi-port, precision-molded, reinforced polypropylene diffuser.

Pressure Switch: High quality, cut-in and differential pressure setting are adjustable.

Mechanical Shaft Seal: Precision lapped and highly polished carbon-ceramic, stainless steel construction. Internal design guarantees continuous water lubrication for maximum protection.

Motor Windings: Superior insulation materials protect against excessive moisture and contaminants...assures prolonged motor life.

Balanced Rotor: Diecast under high pressures for uniform performance and greater efficiency...dynamically balanced.

Heavy-Duty Ball Bearings: Shielded, permanently lubricated bearings, extensively tested to ensure extended life and smooth, quiet operation.

Pump and Motor Shaft: 416 stainless steel for maximum corrosion resistance; one-piece threaded shaft for positive impeller drive and alignment.

ORDERING INFORMATION

CATALOG NUMBER	HP	DESCRIPTION	PIPE TAPPING SIZES			MOTOR VOLTAGE	APPROX. WT. LBS.
			SUCTION	DRIVE	DISCHARGE		
HLC	1/2	Deep Well Jet	1-1/4"	1"	1"	115/230	42
HLD	3/4	Deep Well Jet	1-1/4"	1"	1"	115/230	60
HLE	1	Deep Well Jet	1-1/4"	1"	1"	115/230	65

A Jet Package should be ordered with every Series HL Pump.

NOTE: Pumps installed with a Pro-Source® tank require a 100 PSI relief valve. Pumps installed with a conventional tank require a 75 PSI relief valve. Relief valve must be capable of relieving flow of pump at relief pressure.

Noryl® is registered trademark of General Electric Co.

All other brand or product names are trademarks or registered trademarks of Pentair Ltd.

STA-RITE® ProJet™ HL Series

Cast iron self-priming convertible jet pumps

OUTLINE DIMENSIONS

CATALOG NUMBER	HP	A	B
HLC	1/2	14.25	7.09

HLC

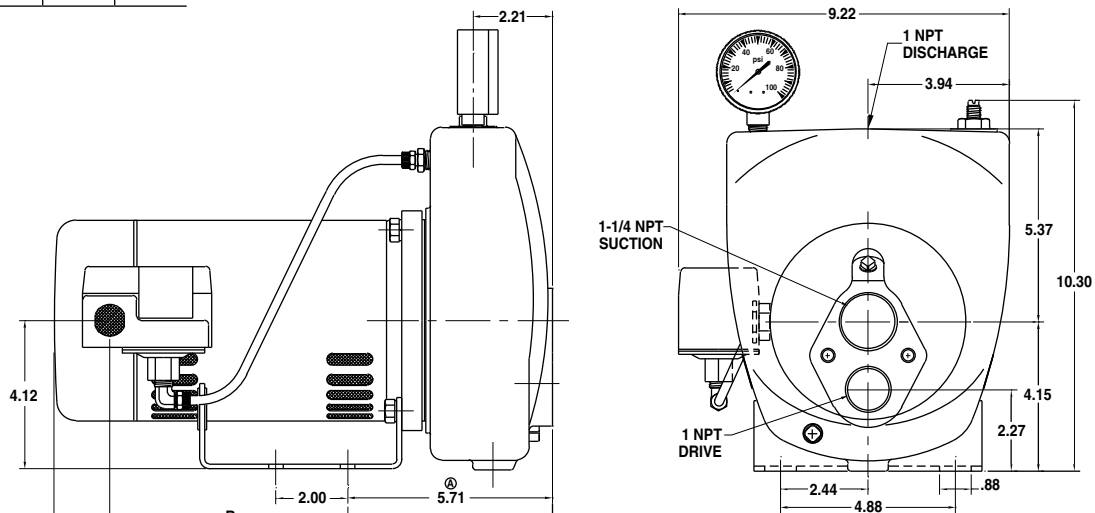

CATALOG NUMBER	HP	A	B
HLD	3/4	15.79	8.03
HLE	1	17.91	9.09

HLD and HLE

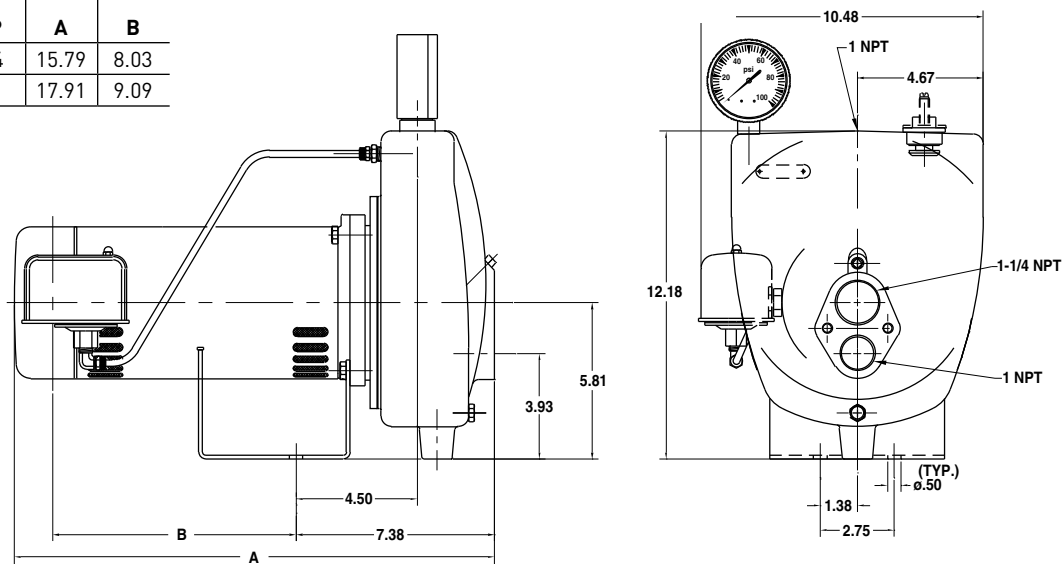

Dimensions (in inches) are for estimating purposes only.

NOTE: 1/4 NPT, 0-100 PSI pressure gauge supplied uninstalled to prevent shipping damage.

STA-RITE® ProJet™ HL Series

Cast iron self-priming convertible jet pumps

PUMP PERFORMANCE (CAPACITY IN GALLONS PER MINUTE) SHALLOW WELL – 5', 10', 15', 20' AND 25' PUMPING DEPTHS

CAT. NO.	HP	DISCH. PRESS.	PUMPING DEPTH TO WATER IN FEET																								
			5 FT. LIFT				10 FT. LIFT				15 FT. LIFT				20 FT. LIFT				25 FT. LIFT								
HLC	1/2	JET PACKAGE	11SD	10SD	29SD	CK5	11SD	10SD	29SD	CK5	11SD	10SD	29SD	CK5	11SD	10SD	29SD	CK5	11SD	10SD	29SD	CK5					
		Venturi N32P-	-68B	-67B	-66B	-66B	-68B	-67B	-66B	-66B	-68B	-67B	-66B	-66B	-68B	-67B	-66B	-66B	-68B	-67B	-66B	-66B					
		Nozzle J43P-	-44	-44	-41	-45	-44	-44	-41	-45	-44	-44	-41	-45	-44	-44	-41	-45	-44	-44	-41	-45					
		20 PSI	20.6	14.4	10.1	6.6	19.0	13.2	9.3	6.1	16.5	11.5	8.1	5.3	13.3	9.5	6.9	4.5	9.8	6.9	5.3	3.4					
		30 PSI	19.6	14.3	9.9	6.5	18.1	13.1	9.1	6.0	15.7	11.4	7.9	5.2	13.3	9.5	6.7	4.4	9.8	6.9	5.1	3.4					
		40 PSI	10.3	12.1	9.8	6.4	9.4	11.2	9.0	5.9	8.2	9.7	7.8	5.1	6.4	8.3	6.6	4.3	3.1	6.3	5.1	3.3					
		50 PSI		4.6	7.3	6.3		4.3	6.7	5.8		3.7	5.8	5.0		2.6	4.9	4.3		1.0	3.8	3.3					
		60 PSI			3.5	5.8			3.2	5.3			2.8	4.6			2.4	3.9				3.0					
Shut-off-PSI	55	59	70	72	53	57	66	67	50	55	64	65	48	53	61	63	46	51	59	61							
HLD	3/4	JET PACKAGE	12SD	11SD	CK1	CK5	CK1	12SD	11SD	CK1	CK5	CK1	12SD	11SD	CK1	CK5	CK1	12SD	11SD	CK1	CK5	CK1	12SD	11SD	CK1	CK5	CK1
		Venturi N32P-	-65	-68B	-72E	-67B	-72	-65	-68B	-72E	-67B	-72	-65	-68B	-72E	-67B	-72	-65	-68B	-72E	-67B	-72	-65	-68B	-72E	-67B	-72
		Nozzle J34P-	-44	-44	-43	-45	-43	-44	-44	-43	-45	-43	-44	-44	-43	-45	-43	-44	-44	-43	-45	-43	-44	-44	-43	-45	-43
		20 PSI	24.2	20.3	14.5	12.6	8.6	23.2	19.4	13.9	12.1	8.3	20.2	16.9	12.1	10.5	7.2	17.7	13.6	10.3	8.2	6.1	12.5	10.4	7.9	6.2	4.7
		30 PSI	24.0	20.3	14.4	12.4	8.5	23.0	19.4	13.8	11.8	8.2	20.0	16.9	12.0	10.3	7.1	17.7	13.6	10.2	8.0	6.0	12.5	10.4	7.8	6.0	4.6
		40 PSI	16.7	16.4	13.7	12.2	8.3	16.0	15.8	13.1	11.7	7.9	13.9	13.7	11.4	10.2	6.9	16.0	11.5	9.7	7.8	5.9	10.3	8.3	7.4	5.8	4.5
		50 PSI			12.6	12.0	8.2			12.1	11.5	7.8			10.5	10.0	6.8			8.9	7.7	5.8			6.8	5.7	4.4
		60 PSI			6.0	8.2	6.1			5.8	7.8	5.9			5.0	6.8	5.1			4.3	5.8	4.3			3.3	4.8	3.3
70 PSI				4.2	2.9				4.0	2.8				3.5	2.4				2.8	2.0				2.0	1.6		
Shut-off-PSI	61	62	71	80	82	59	60	69	78	79	57	58	67	76	77	54	55	65	74	75	52	53	63	72	73		
HLE	1	JET PACKAGE	12SD	CK2	60SD	12SD	CK2	60SD	12SD	CK2	60SD	12SD	CK2	60SD	12SD	CK2	60SD	12SD	CK2	60SD	12SD	CK2	60SD				
		Venturi N32P-	-65	-64	-64	-65	-64	-64	-65	-64	-64	-65	-64	-64	-65	-64	-64	-65	-64	-64	-65	-64	-64				
		Nozzle J34P-	-44	-44	-45	-44	-44	-45	-44	-44	-45	-44	-44	-45	-44	-44	-45	-44	-44	-45	-44	-44	-45				
		20 PSI	26.8	21.6	18.4	24.6	19.9	16.9	21.4	17.3	14.7	18.2	14.7	12.5	13.9	11.2	9.6										
		30 PSI	26.5	21.5	18.1	24.4	19.8	16.7	21.2	17.2	14.5	18.0	14.6	12.3	13.8	11.2	9.4										
		40 PSI	22.9	21.3	17.5	21.0	19.6	16.1	18.3	17.0	14.0	15.6	14.5	11.9	11.9	11.1	9.1										
		50 PSI	15.1	16.8	17.3	13.9	15.4	15.9	12.1	13.4	13.8	10.3	11.4	11.7	7.9	8.7	9.0										
		60 PSI		4.0	15.6		3.7	14.4		3.2	12.5		2.7	10.6		2.1	8.1										
70 PSI			4.1			3.8			3.3			2.8															
Shut-off-PSI	61	71	77	59	69	75	57	67	73	55	65	71	53	63	68												

NOTE: Pumps are supplied with 30-50 pressure switch setting. Cut-in/Cut-out pressure settings are adjustable.

STA-RITE® ProJet™ HL Series

Cast iron self-priming convertible jet pumps

PUMP PERFORMANCE (CAPACITY IN GALLONS PER MINUTE) DEEP WELL (40 PSI) 4" DOUBLE PIPE

CAT. NO.	HP	JET NO.	USES VENTURI	USES NOZZLE	PUMPING DEPTH IN FEET												MAX. PUMP SHUT-OFF PRESSURE PSI	
					20'	30'	40'	50'	60'	70'	80'	90'	100'	110'	120'	JET AT 20 FT. DEPTH	JET AT MAX. DEPTH	
HLC	1/2	CK3	J32P-26	J34P-41	9.4	8.0	6.6										77	68
		54SD	J32P-22	J34P-44	8.0	6.9	5.7	4.8	3.8	3.2							94	70
		CK5	N32P-66B	J34P-45	7.3	6.2	5.0	4.0									83	69
		55SD	J32P-18	J34P-43	5.0	4.3	3.7	3.2	2.6	2.2	1.8	1.5					96	63
HLD	3/4	CK1	N32P-72	J34P-43	13.2	10.8	8.4	6.3	4.2								74	56
		CK2	J32P-24	J34P-44	13.0	11.5	9.9	8.7	7.5	6.6	5.4						105	80
		54SD	J32P-22	J34P-44	8.2	7.7	6.7	6.3	5.8	5.4	4.8	4.0	3.7	3.4	2.7		122	73
HLE	1	54SD	J32P-22	J34P-44	9.5	8.5	7.4	6.9	6.5	6.0	5.4	4.8	4.2	3.6	2.9		127	76

NOTE: Tank body on HLE pump tapped 1-1/4" x 1". On HLE pump, drop pipe should be increased to 1-1/2" x 1-1/4" to ensure adequate capacity from pump.

PUMP PERFORMANCE (CAPACITY IN GALLONS PER MINUTE) DEEP WELL (40 PSI) 2" SINGLE PIPE

CAT. NO.	HP	JET NO.	USES VENTURI	USES NOZZLE	PUMPING DEPTH IN FEET												MAX. PUMP SHUT-OFF PRESSURE PSI	
					20'	30'	40'	50'	60'	70'	80'	90'	100'	110'	120'	JET AT 20 FT. DEPTH	JET AT MAX. DEPTH	
HLC	1/2	54AP	J32P-22	J34P-44	7.4	6.3	5.2	3.9	2.5	2.0							82	54
HLD	3/4	10AP	J32P-24	J34P-44	10.5	10.0	8.1	6.2									96	79
		54AP	J32P-22	J34P-44	6.0	5.3	4.8	4.2	4.1	3.7	3.5	2.8	2.1	1.6			95	53
HLE	1	9AP	J32P-29	J34P-44	11.7	11.1	9.8	6.8									69	57
		8AP	J32P-18	J34P-42	6.7	5.8	5.3	4.7	4.5	4.1	3.8	3.1	2.6	2.0	1.6		129	72

DEEP WELL (40 PSI) 3" SINGLE PIPE

HLC	1/2	9CP	J32P-26	J34P-41	9.4	8.0	6.6										77	68
		54CP	J32P-22	J34P-44	8.0	6.9	5.7	4.8	3.8	3.2							94	70
HLD	3/4	18CP	J32P-24	J34P-44	13.0	11.5	9.9	8.7	7.5	6.6	5.4						106	80
		54CP	J32P-22	J34P-44	8.5	7.7	6.7	6.3	5.8	5.4	4.8	4.0	3.7	3.4	2.7		122	73
		57CP	J32P-33	P122-108	18.0	15.4	12.8	10.8									81	68
HLE	1	54CP	J32P-22	J34P-44	9.5	8.5	7.4	6.9	6.5	6.0	5.4	4.8	4.2	3.6	2.9		127	76

Tank body on HLE pump tapped 1-1/4" x 1". Drop pipe should be increased to 1-1/2" x 1-1/4" to ensure adequate capacity from pump. Tested and rated in accordance with Water Systems Council Standards.

NOTE: Pumps installed with a Pro-Source® tank require a 100 PSI relief valve. Pumps installed with a conventional tank require a 75 PSI relief valve. Relief valve must be capable of relieving entire flow of pump at relief pressure.

