

# EOM

ENGINEERING OPERATION  
& MAINTENANCE

# A200 Accu-Flo Bolted Plastic Pump

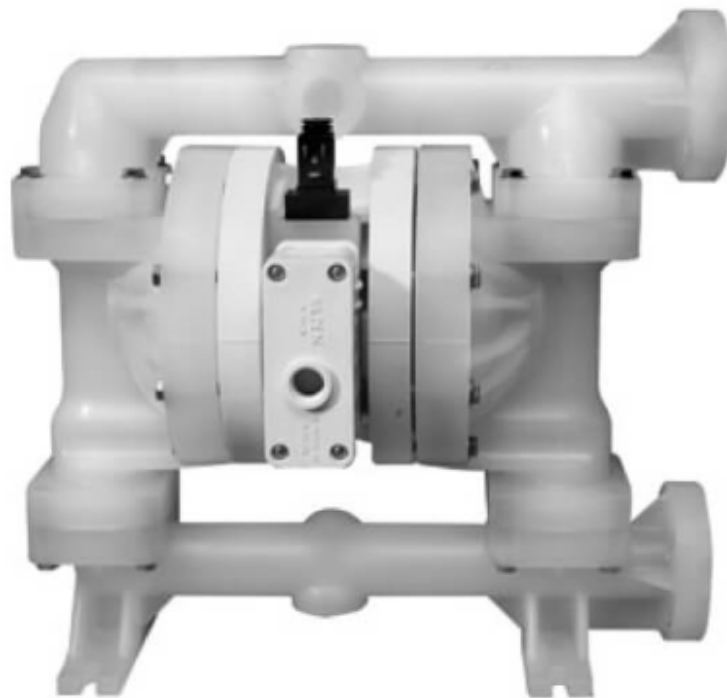

Where Innovation Flows

**WILDEN®**

WIL-11060-E-03



## Contents

<b>Section 1: Precautions - Read First!</b> .....	<b>4</b>
<b>Section 2: Wilden Pump Designation System</b> .....	<b>5</b>
<b>Section 3: How It Works</b> .....	<b>6</b>
<b>Section 4: Dimensional Drawings</b> .....	<b>7</b>
A200P Advanced™ Plastic.....	7
A200B Advanced™ Plastic.....	7
<b>Section 5: Performance</b> .....	<b>8</b>
A200P Rubber Fitted.....	8
A200P PTFE Fitted.....	8
Suction Lift Curves.....	9
<b>Section 6: Suggested Installation, Operation,</b> <b>Maintenance and Troubleshooting</b> .....	<b>10</b>
<b>Section 7: Exploded View and Parts List</b> .....	<b>14</b>
A200P Advanced™ Plastic Rubber/TPE-Fitted.....	14
A200P Advanced™ PTFE-Fitted.....	16
<b>Section 9: Elastomer Options</b> .....	<b>18</b>

**Copyright**

Copyright 2018 PSG®, a Dover Company. All rights reserved.

PSG reserves the right to modify the information and illustrations in this document without prior notice. The product described in this document is furnished under a license agreement or nondisclosure agreement. No part of this document may be reproduced, stored in a retrieval system, or transmitted in any form or any means electronic or mechanical, including photocopying and recording, without the written permission of PSG, a Dover Company, except as described by the terms of those agreements.

This is a non-contractual document. 01-2019.

**Trademarks**

PSG and the PSG logo are registered trademarks of PSG. Wilden® is a registered trademark of PSG California LLC. Pro-Flo® SHIFT and Pro-Flo® are registered trademarks of PSG California LLC. Wil-Flex® is a trademark of PSG California LLC. Saniflex™ is a trademark of PSG California LLC.

All trademarks, names, logos and service marks (collectively "trademarks") in this document are registered and unregistered trademarks of their respective owners. Nothing contained in this document should be construed as granting any license or right to use any trademark without the prior written permission of the trademark owner.

**Warranty**

Each and every product manufactured by Wilden is built to meet the highest standards of quality. Every pump is functionally tested to insure integrity of operation. Wilden warrants that pumps, accessories and parts manufactured or supplied by it to be free from defects in material and workmanship for a period of five (5) years from date of installation or six (6) years from date of manufacture, whichever comes first.

For more information, and to register your Wilden pump for warranty, please visit <https://www.psgdover.com/wilden/support/warranty-registration>.

**Certifications**

**Section 1**

**Precautions - Read First!**

 **TEMPERATURE LIMITS:**

**Wetted Path**

Polypropylene (PP)	0°C to 79.4°C	32°F to 175°F
Polyvinylidene fluoride (PVDF)	-12.2°C to 107.2°C	10°F to 225°F
PTFE PFA	-28.9°C to 87.8°C	-20°F to 190°F

**Elastomers**

Neoprene	-17.8°C to 93.3°C	0°F to 200°F
Buna-N	-12.2°C to 82.2°C	10°F to 180°F
EPDM	-51.1°C to 137.8°C	-60°F to 280°F
FKM®	-40°C to 176.7°C	-40°F to 350°F
Wil-Flex™	-40°C to 107.2°C	-40°F to 225°F
Polyurethane	12.2°C to 65.6°C	10°F to 150°F
Tetra-Flex™ PTFE	4.4°C to 107.2°C	40°F to 225°F
w/Neoprene		
Tetra-Flex™ PTFE w/EPDM	-10°C to 137°C	14°F to 280°F
Polytetrafluoroethylene (PTFE)	4.4°C to 104.4°C	40°F to 220°F

\*Elastomer choice may change temperature limits.

**NOTE:** Not all materials are available for all models. See "Wilden Pump Designation System on page 5 for material options for your pump.

 **CAUTION:** When choosing pump materials, be sure to check the temperature limits for all wetted components. Example: FKM® has a maximum limit of 176.7°C (350°F) but polypropylene has a maximum limit of only 79.4°C (175°F).

 **CAUTION:** Maximum temperature limits are based upon mechanical stress only. Certain chemicals will significantly reduce maximum safe operating temperatures. Consult engineering guide for chemical compatibility and temperature limits.

 **CAUTION:** Always wear safety glasses when operating pump. If diaphragm rupture occurs, material being pumped may be forced out air exhaust.

 **WARNING:** Prevention of static sparking — If static sparking occurs, fire or explosion could result. Proper grounding of pump, valves, and containers is critical when handling flammable fluids or whenever discharge of static electricity is a hazard.

 **NOTE:** Do not exceed 5.2 bar (75 psig) air supply for PFA pumps.

 **CAUTION:** Do not exceed 8.6 bar (125 psig) air supply on polypropylene and PVDF pumps.

 **CAUTION:** Advanced™ series plastic pumps are made with plastic that is not UV stabilized. Direct sunlight for prolonged periods can cause deterioration of plastics.

 **CAUTION:** Before any maintenance or repair is attempted, the compressed air line to the pump should be disconnected and all air pressure allowed to bleed from pump. Disconnect all intake, discharge and air lines. Drain the pump by turning it upside down and allowing any fluid to flow into a suitable container.

 **CAUTION:** Blow out air line for 10 to 20 seconds before attaching to pump to make sure all pipe line debris is clear. Use an in-line air filter. A 5µ (micron) air filter is recommended.

 **NOTE:** Tighten all bolts prior to installation. Fittings may loosen during transportation.

 **NOTE:** When installing polytetrafluoroethylene (PTFE) diaphragms, it is important to tighten outer pistons simultaneously (turning in opposite directions) to ensure tight fit.

 **CAUTION:** Verify the chemical compatibility of the process and cleaning fluid to the pump's component materials in the Chemical Resistance Guide (see E4).

 **CAUTION:** When removing the end cap using compressed air, the air valve end cap may come out with considerable force. Hand protection such as a padded glove or rag should be used to capture the end cap.

 **CAUTION:** Do not over-tighten the air inlet reducer bushing. Additionally, too much torque on the muffler may damage the air valve muffler plate. Do not exceed 0.9 N·m (8 in-lbs).

 **CAUTION:** Only explosion proof (NEMA 7) solenoid valves should be used in areas where explosion proof equipment is required.

 **CAUTION:** Do not lubricate lube-free pumps.

 **CAUTION:** The A200P pump is not submersible.

 **NOTE:** When reinstalling the outer pistons, apply two (2) drops of Loctite® 246 to the shaft internal threads before the diaphragm assembly

**Section 2**

**WILDEN PUMP DESIGNATION SYSTEM**

**A200 ADVANCED™  
PLASTIC**

**25 mm (1") Pump  
Maximum Flow Rate:  
170 LPM (45 GPM)**

**LEGEND**

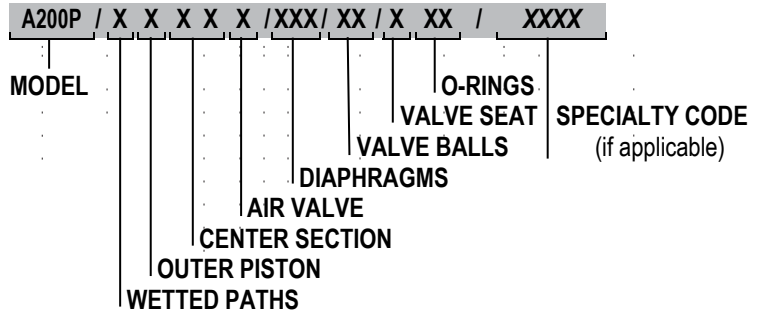

**MATERIAL CODES**

**MODEL**

A200P = PLASTIC  
ACCU-FLO™

**WETTED PATH**

K = PVDF  
P = POLYPROPYLENE

**OUTER PISTON**

K = PVDF

**CENTER SECTION**

PP = POLYPROPYLENE

**AIR VALVE**

P = POLYPROPYLENE

**DIAPHRAGMS**

BNS = BUNA-N (Red Dot)  
EPS = EPDM (Blue Dot)  
FSS = SANIFLEX™  
[Hytrel® (Cream)]  
NES = NEOPRENE (Green Dot)  
PUS = POLYURETHANE (Clear)  
TEU = PTFE W/EPDM  
BACK-UP (White)  
TNU = PTFE W/NEOPRENE  
BACK-UP (White)  
TSU = PTFE W/SANIFLEX™  
BACK-UP (White)  
VTS = FKM® (White Dot)  
WFS = WIL-FLEX™ [Santoprene®  
(Orange Dot)]

**VALVE BALLS**

BN = BUNA-N (Red Dot)  
EP = EPDM (Blue Dot)  
FS = SANIFLEX™  
[Hytrel® (Cream)]  
NE = NEOPRENE (Green Dot)  
PU = POLYURETHANE (Brown)  
TF = PTFE (White)  
VT = FKM® (White Dot)  
WF = WIL-FLEX™ [Santoprene®  
(Orange Dot)]

**VALVE SEATS**

K = PVDF  
P = POLYPROPYLENE

**VALVE SEAT O-RINGS**

BN = BUNA-N  
PU = POLYURETHANE (Brown)  
TV = PTFE ENCAP. FKM®  
WF = WIL-FLEX™ (Santoprene®)

**SPECIALTY CODES**

- 0150 Accu-Flo™, 24V DC coil
- 0151 Accu-Flo™, 24V AC / 12V DC coil
- 0167 Accu-Flo™, 24V AC / 12V DC coil,  
Wil-Gard II™ 110V
- 0180 Accu-Flo™, 24V AC / 12V DC coil, PFA coated
- 0360 Accu-Flo™, 24V DC coil, DIN flange

**NOTE:** Most elastomeric materials use colored dots for identification.

**NOTE:** Not all models are available with all material options.

Buna-N are registered trademarks of DuPont Dow Elastomers.

Santoprene® is a registered trademark of Monsanto Company, licensed to Advanced Elastomer Systems, L.P.

Hytrel® is a registered trademark of DuPont Dow Elastomers.

**Section 3**

**HOW IT WORKS — PUMP**

The Wilden diaphragm pump is an air-operated, positive displacement, self-priming pump. These drawings show flow pattern through the pump upon its initial stroke. It is assumed the pump has no fluid in it prior to its initial stroke.

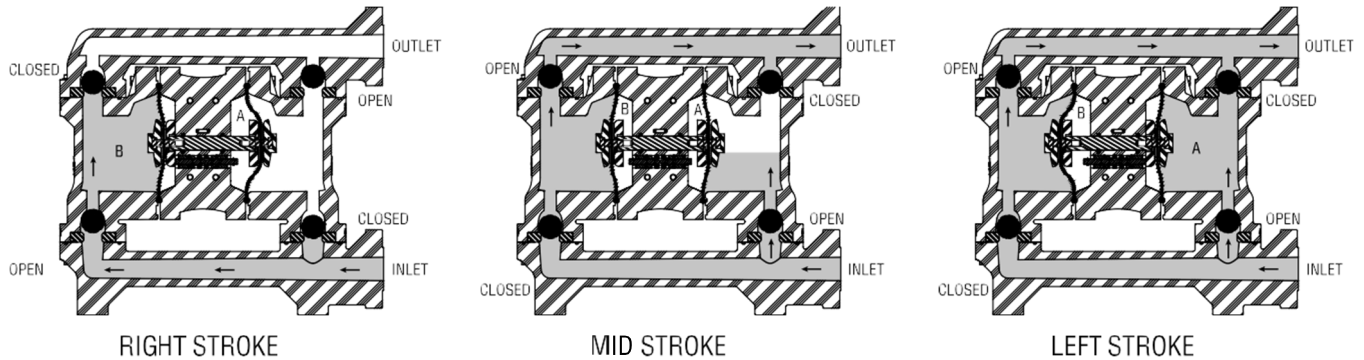
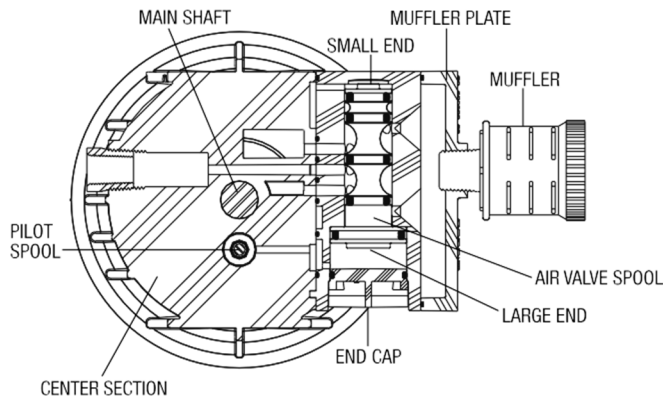

**FIGURE 1** The air valve directs pressurized air to the back side of diaphragm A. The compressed air is applied directly to the liquid column separated by elastomeric diaphragms. The diaphragm acts as a separation membrane between the compressed air and liquid, balancing the load and removing mechanical stress from the diaphragm. The compressed air moves the diaphragm away from the center block of the pump. The opposite diaphragm is pulled in by the shaft connected to the pressurized diaphragm. Diaphragm B is on its suction stroke; air behind the diaphragm has been forced out to the atmosphere through the exhaust port of the pump. The movement of diaphragm B toward the center block of the pump creates a vacuum within chamber B. Atmospheric pressure forces fluid into the inlet manifold forcing the inlet valve ball off its seat. Liquid is free to move past the inlet valve ball and fill the liquid chamber (see shaded area).

**FIGURE 2** When the pressurized diaphragm, diaphragm A, reaches the limit of its discharge stroke, the air valve redirects pressurized air to the back side of diaphragm B. The pressurized air forces diaphragm B away from the center block while pulling diaphragm A to the center block. Diaphragm B is now on its discharge stroke. Diaphragm B forces the inlet valve ball onto its seat due to the hydraulic forces developed in the liquid chamber and manifold of the pump. These same hydraulic forces lift the discharge valve ball off its seat, while the opposite discharge valve behind is forced onto its seat, forcing fluid to flow through the pump discharge. The movement of diaphragm A toward the center block of the pump creates a vacuum within liquid chamber A. Atmospheric pressure forces fluid into the inlet manifold of the pump. The inlet valve ball is forced off its seat allowing the fluid being pumped to fill the liquid chamber.

**FIGURE 3** At completion of the stroke, the air valve again redirects air to the back side of diaphragm A, which starts diaphragm B on its exhaust stroke. As the pump reaches its original starting point, each diaphragm has gone through one exhaust and one discharge stroke. This constitutes one complete pumping cycle. The pump may take several cycles to completely prime depending on the conditions of the application.

**HOW IT WORKS — AIR DISTRIBUTION SYSTEM**



The Pro-Flo® patented air distribution system incorporates three moving parts: the air valve spool, the pilot spool, and the main shaft/diaphragm assembly. The heart of the system is the air valve spool and air valve. As shown in Figure A, this valve design incorporates an unbalanced spool. The smaller end of the spool is pressurized continuously, while the large end is alternately pressurized then exhausted to move the spool. The spool directs pressurized air to one air chamber while exhausting the other. The air causes the main shaft/diaphragm assembly to shift to one side — discharging liquid on that side and pulling liquid in on the other side. When the shaft reaches the end of its stroke, the inner piston actuates the pilot spool, which pressurizes and exhausts the large end of the air valve spool. The repositioning of the air valve spool routes the air to the other air chamber.

**Section 4**

**DIMENSIONAL DRAWING**

**A200P Advanced™ Plastic**

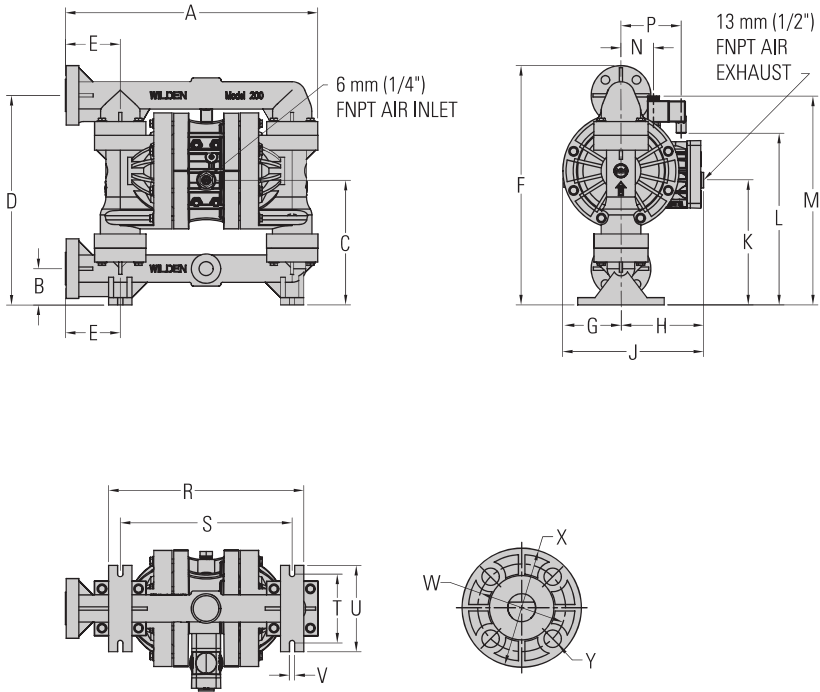

**DIMENSIONS**

ITEM	METRIC (mm)	STANDARD (inch)
A	457	18.0
B	66	2.6
C	259	10.2
D	381	15.0
E	99	3.9
F	434	17.1
G	104	4.1
H	150	5.9
J	257	10.1
K	226	8.9
L	310	12.2
M	378	14.9
N	58	2.3
P	109	4.3
R	353	13.9
S	310	12.2
T	124	4.9
U	157	6.2
V	10	0.4
	DIN (mm)	ANSI (inch)
W	85 DIA.	3.1 DIA.
X	115 DIA.	4.3 DIA.
Y	14 DIA.	0.6 DIA.

**A200B Advanced™ Plastic**

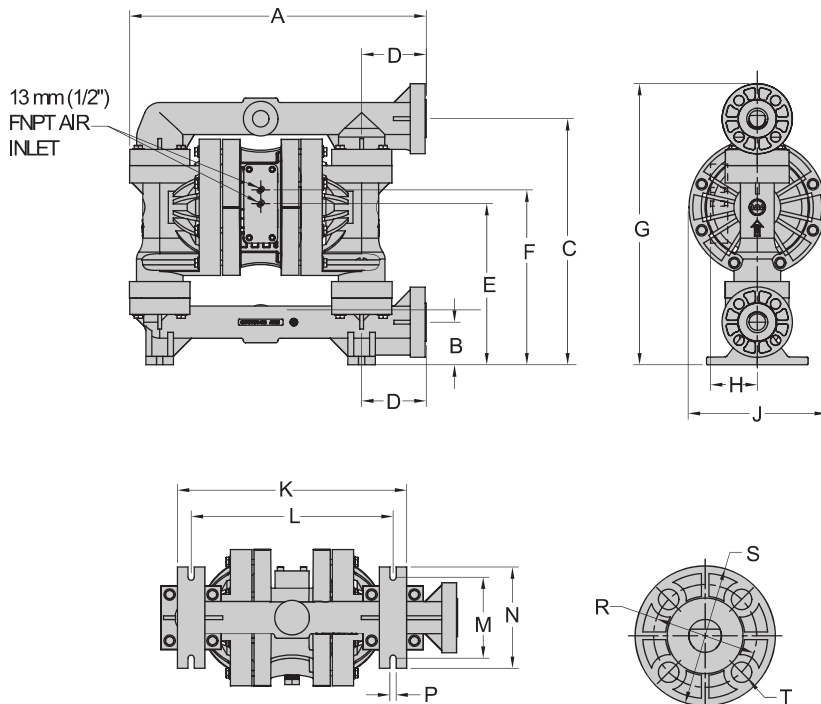

**DIMENSIONS**

ITEM	METRIC (mm)	STANDARD (inch)
A	457	18.0
B	66	2.6
C	381	15.0
D	99	3.9
E	249	9.8
F	269	10.6
G	434	17.1
H	71	2.8
J	213	8.4
K	353	13.9
L	310	12.2
M	124	4.9
N	157	6.2
P	10	0.4
	DIN (mm)	ANSI (inch)
W	85 DIA.	3.1 DIA.
X	115 DIA.	4.3 DIA.
Y	14 DIA.	0.6 DIA.

**Section 5**

**A200P  
RUBBER-FITTED**

Height..... 434 mm (17.1")  
 Width..... 457 mm (18.0")  
 Depth..... 257 mm (10.1")  
 Est. Ship Weight.....  
     Polypropylene 14 kg (31 lbs)  
     PVDF 19 kg (41 lbs)  
 Air Inlet..... 6 mm (1/4")  
 Inlet..... 25 mm (1")  
 Outlet..... 25 mm (1")  
 Suction Lift..... 4.8 m Dry (15.9')  
                     9.3 m Wet (30.6')  
 Disp. Per Stroke<sup>1</sup>..... 0.34 l (0.09 gal.)  
 Max. Flow Rate..... 170 lpm (45 gpm)  
 Max. Size Solids..... 4.8 mm (3/16")

<sup>1</sup>Displacement per stroke was calculated at 4.8 bar (70 psig) air inlet pressure against a 2 bar (30 psig) head pressure.

**Example:** To pump 75.7 lpm (20 gpm) against a discharge pressure head of 3.4 bar (50 psig) requires 5.5 bar (80 psig) and 34 Nm<sup>3</sup>/h (20 scfm) air consumption.

**Caution:** Do not exceed 8.6 bar (125 psig) air supply pressure.

**A200P  
PTFE-FITTED**

Height..... 434 mm (17.1")  
 Width..... 457 mm (18.0")  
 Depth..... 257 mm (10.1")  
 Est. Ship Weight.....  
     Polypropylene 14 kg (31 lbs)  
     PVDF 19 kg (41 lbs)  
 Air Inlet..... 6 mm (1/4")  
 Inlet..... 25 mm (1")  
 Outlet..... 25 mm (1")  
 Suction Lift..... 4.8 m Dry (15.9')  
                     9.3 m Wet (30.6')  
 Disp. Per Stroke<sup>1</sup>..... 0.34 l (0.09 gal.)  
 Max. Flow Rate..... 170 lpm (45 gpm)  
 Max. Size Solids..... 4.8 mm (3/16")

<sup>1</sup>Displacement per stroke was calculated at 4.8 bar (70 psig) air inlet pressure against a 2 bar (30 psig) head pressure.

**Example:** To pump 30.3 lpm (8 gpm) against a discharge pressure head of 4.1 bar (60 psig) requires 5.5 bar (80 psig) and 20.4 Nm<sup>3</sup>/h (12 scfm) air consumption.

**Caution:** Do not exceed 8.6 bar (125 psig) air supply pressure.

**PERFORMANCE**

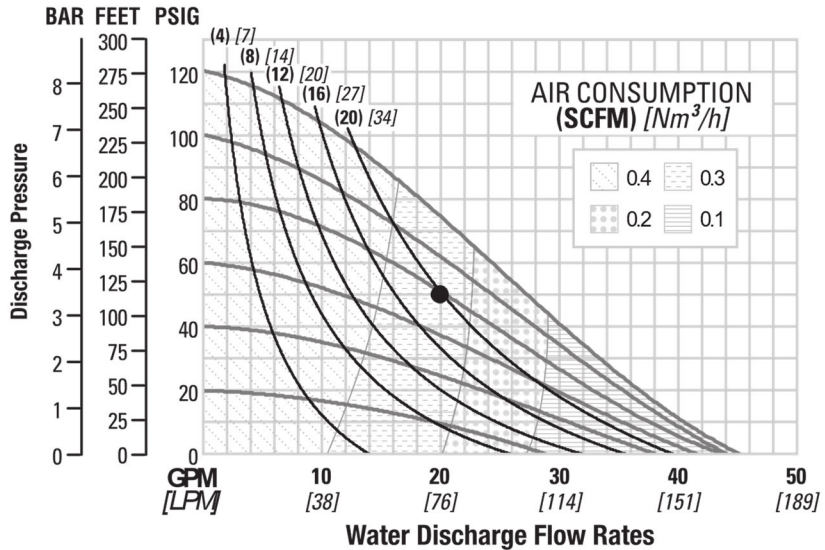

Flow rates indicated on chart were determined by pumping water.

For optimum life and performance, pumps should be specified so that daily operation parameters will fall in the center of the pump performance curve.

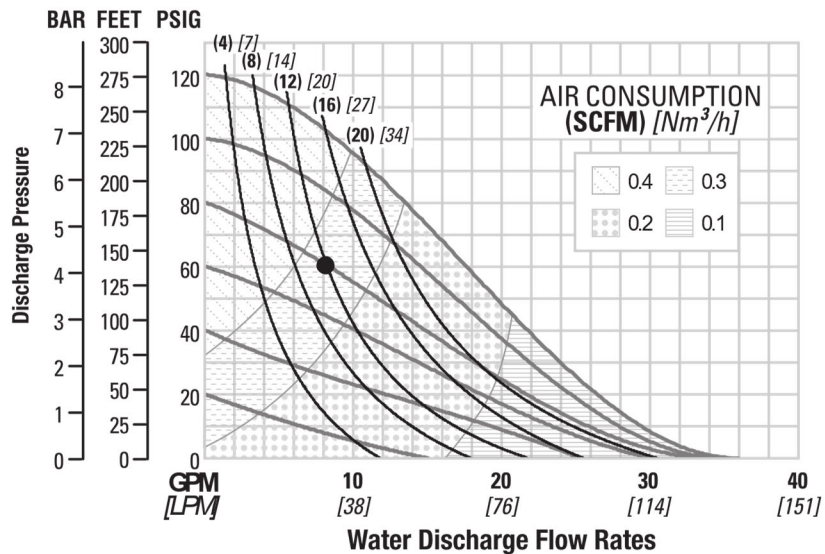

Flow rates indicated on chart were determined by pumping water.

For optimum life and performance, pumps should be specified so that daily operation parameters will fall in the center of the pump performance curve.

## SUCTION LIFT CURVES

### A200P ADVANCED™ PLASTIC SUCTION-LIFT CAPABILITY

These curves demonstrate the flow created when the stroke rate is modified under static air and fluid pressure condition. This curve can be applied to different pressure conditions to estimate the change in flow due to stroke rate.

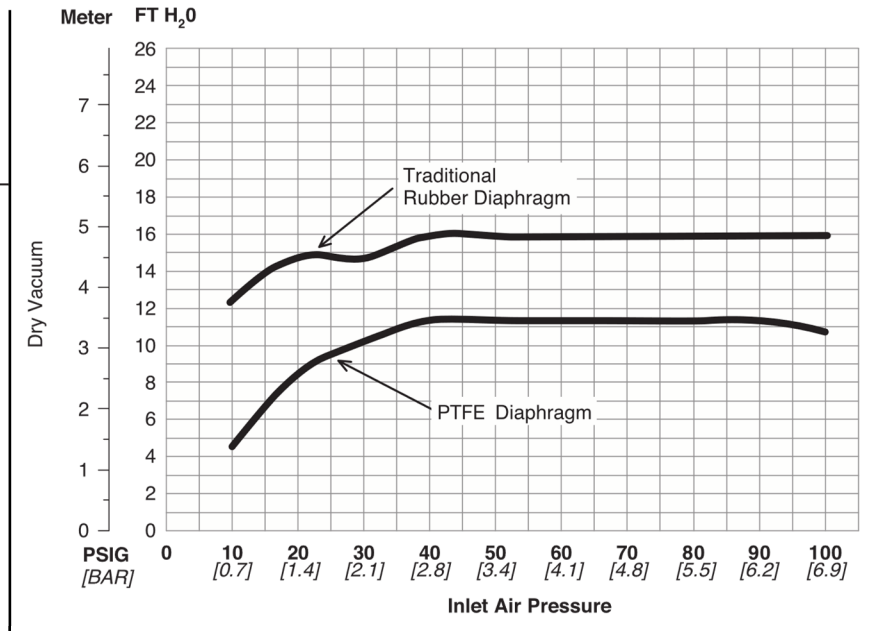

## Section 6

# Suggested Installation, Operation, Maintenance and Troubleshooting

All Wilden pumps are manufactured with a variety of materials for the air distribution system, liquid path and elastomers. This variety is offered to satisfy the temperature, chemical compatibility, abrasion and flex life requirements for most applications. Consult manual for available materials and temperature limitations for this pump model.

For Accu-Flo™ models only, all wiring used to operate the pump should be placed and connected according to all applicable electrical codes. It is important that the wiring be of adequate gauge to carry the current required to operate the pump. In addition, it is necessary that the electrical power supply be large enough to supply the current required to operate the pump. Wiring should be above ground level if possible (in case of fluid spill or leakage), and all wiring and connections which could become wet or damp should be made watertight.

The suction pipe used for installation should be sized equal to, or greater than, the pump liquid inlet connection. This will minimize pump cavitation and potential blockages of the pump inlet. The discharge piping should also be sized equal to, or greater than, the pump liquid discharge connection. If the pump is to be used in a self-priming application, be sure that all connections are airtight and that the suction lift is within the pump's ability. (Consult manual for suction lift information.) Note: Materials of construction and elastomer materials have an effect on suction lift parameters.

### Installation

Months of careful planning, study, and selection efforts can result in unsatisfactory pump performance if installation details are left to chance. Premature failure and long term dissatisfaction can be avoided if reasonable care is exercised throughout the installation process.

### Location

Noise, safety, and other logistical factors usually dictate where equipment should be situated on the production floor. Multiple installations with conflicting requirements can result in congestion of utility areas, leaving few choices for additional pumps.

Within the framework of these and other existing conditions, every pump should be located in such a way that five key factors are balanced against each other to maximum advantage:

- **Access:** First, the location should be accessible. If it is easy to reach the pump, maintenance personnel will have an easier time carrying out routine inspections and adjustments. Should major repairs become necessary, ease of access can play a key role in speeding the repair process and reducing total downtime.
- **Air Supply:** Every pump location should have an air line large enough to supply the volume of air necessary to achieve the desired pumping rate (see Section 5).  
For best results, the pumps should use a 5µ (micron) air filter, needle valve and regulator. The use of an air filter before the pump will insure that the majority of any pipeline contaminants will be eliminated.
- **Solenoid Operation:** When operation is controlled by a solenoid valve in the air line, three-way valves should be used, thus allowing trapped air to bleed off and improving pump performance. Pumping volume can be set by counting the number of strokes per minute and multiplying by displacement per stroke.
- **Sound:** Sound levels are reduced using the standard Wilden muffler element. Other mufflers can be used, but usually reduce pump performance.
- **Elevation:** Selecting a site that is well within the pump's dynamic lift capability will assure that loss-of-prime troubles will be eliminated. In addition, pump efficiency can be adversely affected if proper attention is not given to site location.
- **Piping:** Final determination of the pump site should not be made until the piping problems of each possible location have been evaluated. The impact of current and future installations should be considered ahead of time to make sure that inadvertent restrictions are not created for any remaining sites.

The best choice possible will be a site involving the shortest and straightest hook-up of suction and discharge piping. Unnecessary elbows, bends, and fittings should be avoided. Pipe sizes should be selected to keep friction losses within practical limits. All piping should be supported independently of the pump. In addition, the piping should be aligned to avoid placing stresses on the pump fittings.

Flexible hose can be installed to aid in absorbing the forces created by the natural reciprocating action of the pump. If the pump is to be bolted down to a solid location, a mounting pad placed between the pump and the foundation will assist in minimizing pump vibration. Flexible connections between the pump and rigid piping will also assist in minimizing pump vibration. If quick-closing valves are installed at any point in the discharge system, or if pulsation within a system becomes a problem, a surge suppressor should be installed to protect the pump, piping and gauges from surges and water hammer.

When pumps are installed in applications involving flooded suction or suction head pressures, a gate valve should be installed in the suction line to permit closing of the line for pump service.

If the pump is to be used in a self-priming application, be sure that all connections are airtight and that the suction-lift is within the ability of the model. Note: Materials of construction and elastomer material have an effect on suction lift parameters. Please consult Wilden distributors for specifics.

Pumps in service with a positive suction head are most efficient when inlet pressure is limited to 0.5–0.7 bar (7–10 psig). Premature diaphragm failure may occur if positive suction is 0.7 bar (10 psig) and higher.

**WHENEVER THE POSSIBILITY EXISTS THAT LARGE SOLID OBJECTS MAY BE SUCKED INTO THE PUMP, A STRAINER SHOULD BE USED ON THE SUCTION LINE.**



**CAUTION: DO NOT EXCEED RATED MAXIMUM PRESSURE AS STATED IN CAUTIONS AND WARNINGS, SECTION 1.**

## Suggested Installation, Operation, Maintenance and Troubleshooting

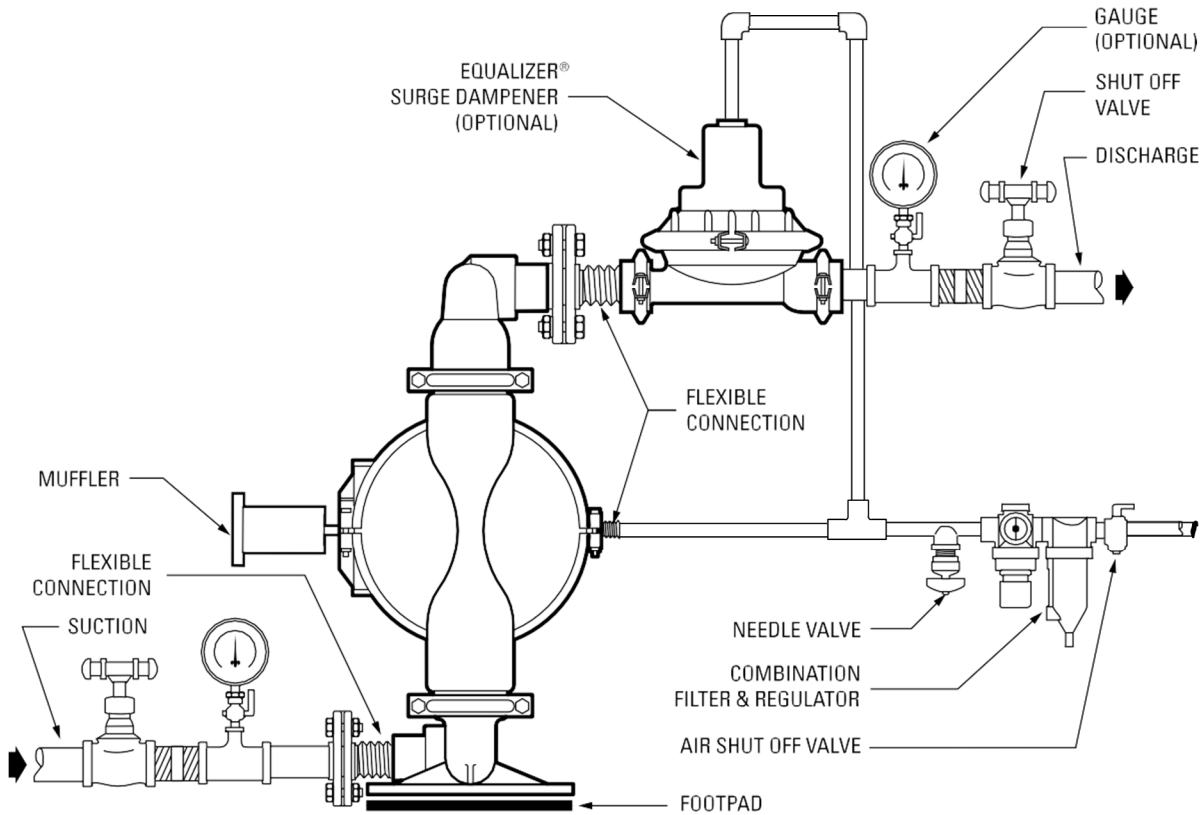

**NOTE:** In the event of a power failure, the shut off valve should be closed, if the restarting of the pump is not desirable once power is regained.

**Air-Operated Pumps:** To stop the pump from operating in an emergency situation, simply close the.

shut off valve (user supplied) installed in the air supply line. A properly functioning valve will stop the air supply to the pump, therefore stopping output. This shut off valve should be located far enough away from the pumping equipment such that it can be reached safely in an emergency situation.

# Suggested Installation, Operation, Maintenance and Troubleshooting

## Operating Principles Behind Accu-Flo™ Pumps

### Operation

The A200P is pre-lubricated, and does not require in-line lubrication. Additional lubrication will not damage the pump, however if the pump is heavily lubricated by an external source, the pump's internal lubrication may be washed away. If the pump is then moved to a non-lubricated location, it may need to be disassembled and re-lubricated as described in the ASSEMBLY/DISASSEMBLY INSTRUCTIONS.

Pump discharge rate can be controlled by limiting the solenoid, the volume, and/or pressure of the air supply to the pump. A regulator is used to control air pressure while a needle valve is used to control volume. Pump discharge rate can also be controlled by throttling the pump discharge by partially closing a valve in the discharge line of the pump. This action increases friction loss which reduces flow rate. (See Section 5.) This is useful when the need exists to control the pump from a remote location. When the pump discharge pressure equals or exceeds the air supply pressure, the pump will stop; no bypass or pressure relief valve is needed, and pump damage will not occur. The pump has reached a "deadhead" situation and can be restarted by reducing the fluid discharge pressure or increasing the air inlet pressure. The Wilden A200P pump runs solely on compressed air and does not generate heat, therefore your process fluid temperature will not be affected.

### Maintenance and Inspections

Since each application is unique, maintenance schedules may be different for every pump. Frequency of use, line pressure, viscosity and abrasiveness of process fluid all affect the parts life of a Wilden pump. Periodic inspections have been found to offer the best means for preventing unscheduled pump downtime. Personnel familiar with the pump's construction and service should be informed of any abnormalities that are detected during operation.

### Records

When service is required, a record should be made of all necessary repairs and replacements. Over a period of time, such records can become a valuable tool for predicting and preventing future maintenance problems and unscheduled downtime. In addition, accurate records make it possible to identify pumps that are poorly suited to their applications.

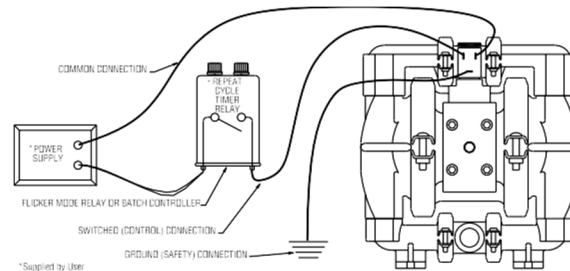

## Suggested Operation & Maintenance

### Operation

The pump will not shift reliably unless the minimum supply pressure is provided. For the A200P the minimum supply pressure for reliable operation is 2.7 bar (40 psig).

The solenoid operated pump is permanently lubricated during assembly, and requires no additional lubrication under normal operation. If the unit runs under extreme conditions (continuous operation at high speeds), it may be necessary to relubricate the center block with a buna-n compatible white bearing grease every 50 million cycles. Continuous lubrication with a compatible oil is not harmful, and will provide longer seal life, but it may flush all grease out of the unit.

A red button on the side of the air valve is a manual override; when actuated it will shift the valve as if an electric current had actuated the solenoid.

### Records

When service is required, a record should be made of all necessary repairs and replacements. Over a period of time, such records can become a valuable

tool for predicting and preventing future maintenance problems and unscheduled downtime. In addition, accurate records make it possible to identify pumps that are poorly suited to their applications.

### Maintenance and Inspections

Since each application is unique, maintenance schedules may be different for every pump. Frequency of use, line pressure, viscosity and abrasiveness of process fluid all effect the parts life of a Wilden pump. Periodic inspections have been found to offer the best means for preventing unscheduled pump downtime. Personnel familiar with the pump's construction and service should be informed of any abnormalities that are detected during operation. Internal maintenance is not recommended for Accu-Flo™ solenoid air valves. When worn or damaged, a new air valve body, coil or terminal connector must be purchased. Please consult Section 8 for part numbers.

# Suggested Installation, Operation, Maintenance and Troubleshooting

## Operating

## Troubleshooting

### ***Pump will not run.***

1. Check for pressurized air at the inlet.
2. Check air inlet and filter for debris.
3. Connect a test lamp to the two wires which run to pump and ensure that the lamp cycles on and off.
4. Make sure that the air valve manual override (small red knob on front of valve) is switched to the "0" position.
5. Check pilot pressure vent at the top of the operator/ coil assembly to ensure that it is not clogged.
6. Check for a worn out air valve. If air continually blows out the exhaust in very large quantities, the air valve seals may be worn beyond their ability to function. In this case, the valve must be replaced.
7. **NOTE:** Before the valve is scrapped, it is possible that it may be saved by completely disassembling the valve, cleaning all components and relubricating the valve.

### ***Pump runs but little or no fluid comes out.***

1. Check that the discharge isolation valve is not closed.
2. Check that the electronic signal is slow enough that the pump is able to complete each physical stroke before it is signaled to change direction. The time required to complete the stroke is determined by a variety of factors which include fluid viscosity and head pressure.
3. Check for pump cavitation; slow pump speed down to match the thickness of the material being pumped.
4. Check for sticking ball check valves. If the material being pumped is not compatible with the pump elastomers, swelling may occur. Replace ball check valves and o-ring with the proper elastomers.
5. Check to make sure that all suction connections are airtight, and that the clamp bands are properly tightened.

### ***Pump air passages blocked with ice.***

1. Check for excessive moisture in compressed air line. As the air expands out the exhaust during the operation of the pump, water vapor entrapped in the compressed air can freeze and block the air passageways in the pump. If this occurs, it may be necessary to install a coalescing filter, an air dryer, or a hot air generator for the compressed air.

### ***Air bubbles in pump discharge.***

1. Check for ruptured diaphragm.
2. Check tightness of clamp bands, and the integrity of the o-rings, especially at intake manifold.

### ***Product comes out of the air exhaust.***

1. Check for diaphragm rupture.
2. Check tightness of piston plates to shaft.

### ***Pump rattles.***

1. See E10 Troubleshooting Guide.
2. Create false discharge head or suction lift.

### ***Solenoid buzzes or solenoid burnout.***

1. Incorrect voltage, faulty or dirty solenoid.

### ***Solenoid valve fails to shift electrically but shifts with manual override.***

1. Incorrect voltage, defective coil or wiring.

### ***Solenoid valve fails to shift electrically or with manual over-ride.***

1. Inadequate air supply, contamination, inadequate or improper lubrication, mechanical binding in the valve.

### ***Valve shifts but fails to return.***

1. Broken spring, mechanical binding.

### ***Excessive leaking from air valve vent.***

1. Worn seals in air valve.

**Section 7**

**EXPLODED VIEW AND PARTS LISTING**

**A200P ADVANCED™ PLASTIC**

Rubber/TPE-Fitted

EXPLODED VIEW

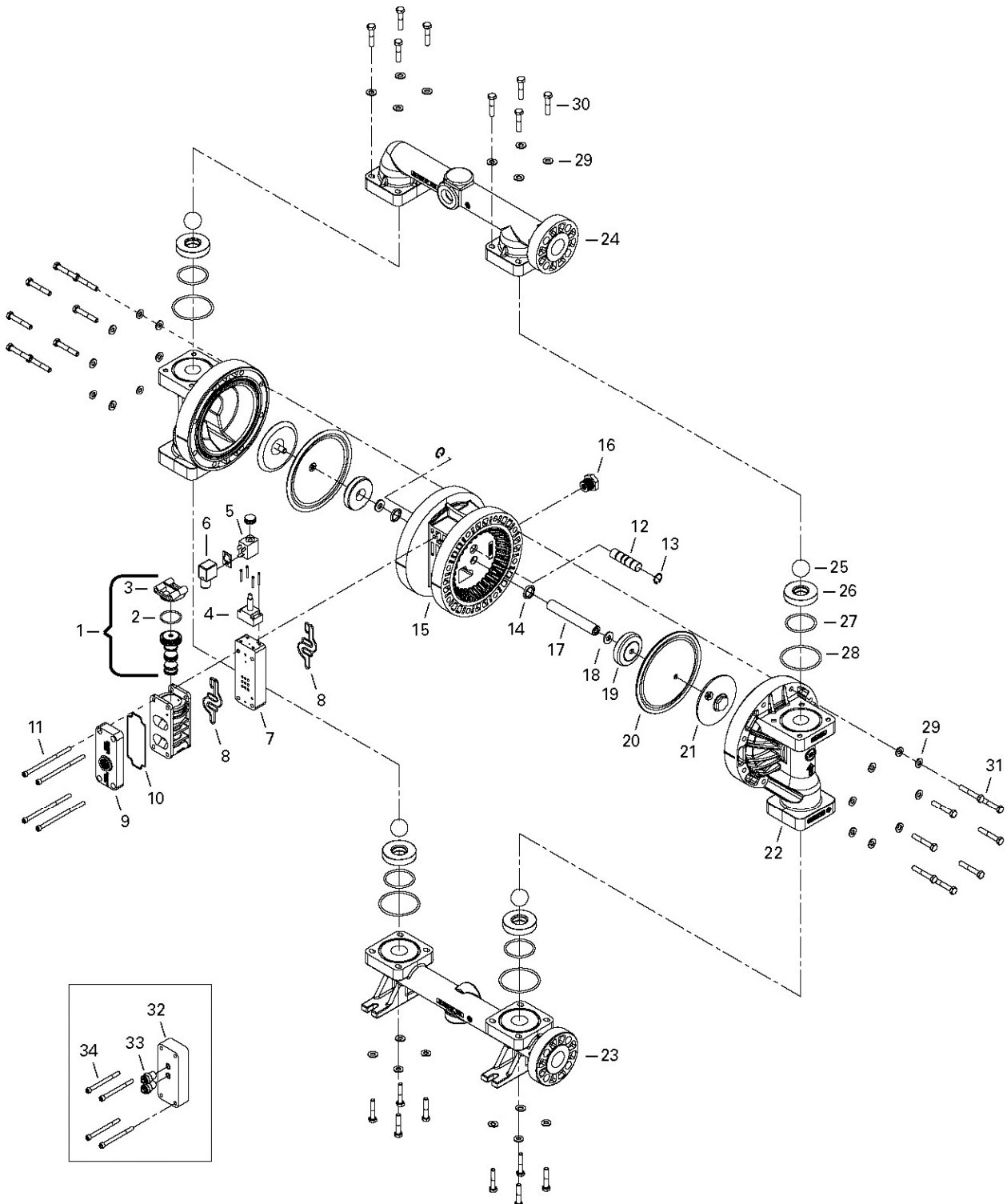

## Exploded View and Parts List

No.	Part Description	Qty.	A200P/PKPPP P/N	A200P/KKPPP P/N
1	Assembly, Air Valve, P1/P2	1	01-2010-20	01-2010-20
2	O-Ring, End Cap	1	01-2395-52	01-2395-52
3	End Cap	1	01-2332-20	01-2332-20
4	Operator, Solenoid, NEMA 4	1	00-2120-99	00-2120-99
5	Coil	1	***	***
6	Connector, Solenoid Coil	1	00-2130-99	00-2130-99
7	Solenoid Spacer Plate, P1/P2, Poly	1	01-2160-20	01-2160-20
8	Gasket, Air Valve, Pro-Flo®	2	01-2615-52	01-2615-52
9	Muffler Plate, Pro-Flo®	1	01-3181-20	01-3181-20
10	Gasket, Muffler Plate	1	01-3505-52	01-3505-52
11	Screw, SHC, 1/4-20 X 4.00	4	02-6002-03	02-6002-03
12	Assembly, Pilot Plug, A2P	1	02-2285-99	02-2285-99
13	Retaining Ring	2	00-2650-03	00-2650-03
<b>14</b>	<b>Glyd™ Ring II</b>	<b>2</b>	<b>02-3210-55-225</b>	<b>02-3210-55-225</b>
15	Center Section, P200, Poly	1	02-3141-20	02-3141-20
16	Bushing Reducer	1	01-6950-20	01-6950-20
17	Shaft, Straight, P2	1	02-3810-03	02-3810-03
18	Washer, Disc Spring (.413 X.906)	2	02-6802-08	02-6802-08
19	Piston, Inner, P2	2	02-3701-01	02-3701-01
<b>20</b>	<b>Diaphragm, Primary</b>	<b>2</b>	*	*
21	Piston, Outer, P2	2	02-4550-21-500	02-4550-21-500
22	Chamber, Liquid, Adv	2	02-5005-20	02-5005-21
23	Manifold, Inlet, ANSI2	1	02-5090-20	02-5090-21
24	Manifold, Discharge, ANSI1	1	02-5030-20	02-5030-21
<b>25</b>	<b>Ball, Valve</b>	<b>4</b>	*	*
<b>26</b>	<b>Seat, Valve, Bolted, Poly</b>	<b>4</b>	<b>02-1125-20</b>	<b>02-1125-21</b>
<b>27</b>	<b>O-Ring (1.859 X.139)</b>	<b>4</b>	*	*
<b>28</b>	<b>O-Ring (2.734 X.139)</b>	<b>4</b>	*	*
29	Washer, Flat, 5/16	32	02-6731-03	02-6731-03
30	Screw, HHC, 5/16-18 X 1.50	16	02-6181-03	02-6181-03
31	Screw, HHC, 5/16-18 X 2	16	02-6191-03	02-6191-03
	Muffler, 1/2" (not pictured)	1	02-3510-99	02-3510-99

\* Refer to corresponding elastomer chart in Section 8

\*\*\* Refer to coil voltage selection chart in Section 8

<sup>1</sup>DIN Flange: Polypropylene = 02-5031-02, PVDF = 02-5031-21

<sup>2</sup>DIN Flange: Polypropylene = 02-5091-02, PVDF = 02-5091-21

All boldface items are primary wear parts.

### Adapter Block Option for A200B

No.	Part Description	Qty.	A200P/PPPP P/N
32	Adapter Block	1	00-2155-20
33	Fitting, Air Inlet	2	00-2170-20
34	Screw, HHC	4	04-6000-03

# EXPLODED VIEW AND PARTS LISTING

**A200P ADVANCED™ PLASTIC**

PTFE-Fitted

EXPLODED VIEW

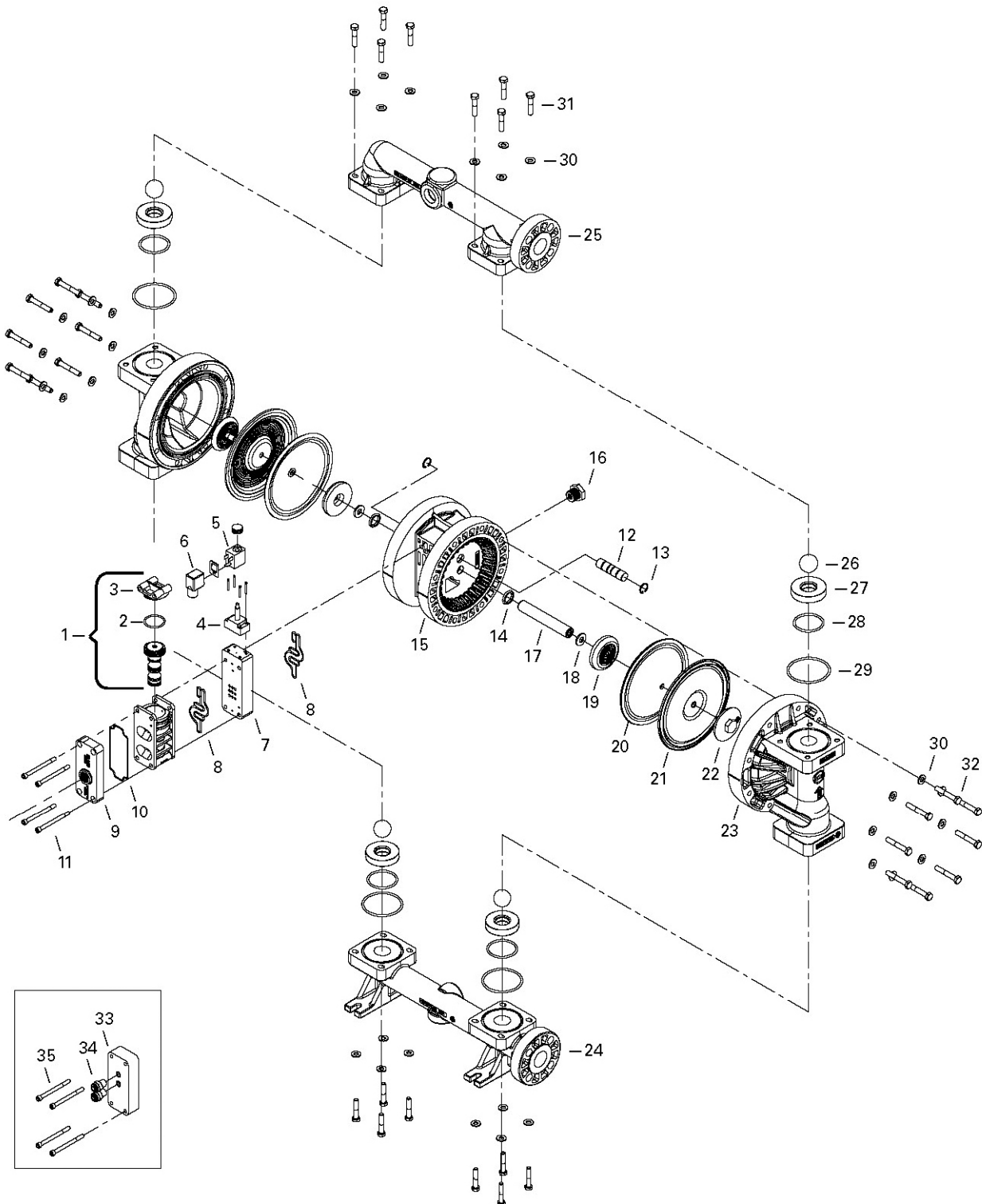

## Exploded View and Parts List

No.	Part Description	Qty.	A200P/PKPPP P/N	A200P/KKPPP P/N
1	Assembly, Air Valve, P1/P2	1	01-2010-20	01-2010-20
2	O-Ring, End Cap	1	01-2395-52	01-2395-52
3	End Cap	1	01-2332-20	01-2332-20
4	Operator, Solenoid, NEMA 4	1	00-2120-99	00-2120-99
5	Coil	1	***	***
6	Connector, Solenoid Coil	1	00-2130-99	00-2130-99
7	Solenoid Spacer Plate, P1/P2, Poly	1	01-2160-20	01-2160-20
8	Gasket, Air Valve, Pro-Flo®	2	01-2615-52	01-2615-52
9	Muffler Plate, Pro-Flo®	1	01-3181-20	01-3181-20
10	Gasket, Muffler Plate	1	01-3505-52	01-3505-52
11	Screw, SHC, 1/4-20 X 4.00	4	02-6002-03	02-6002-03
12	Assembly, Pilot Plug, A2P	1	02-2285-99	02-2285-99
13	Retaining Ring	2	00-2650-03	00-2650-03
<b>14</b>	<b>Glyd™ Ring II</b>	<b>2</b>	<b>02-3210-55-225</b>	<b>02-3210-55-225</b>
15	Center Section, P200, Poly	1	02-3142-20	02-3142-20
16	Bushing Reducer	1	01-6950-20	01-6950-20
17	Shaft, Straight, P2	1	02-3840-03	02-3840-03
18	Washer, Disc Spring (.413 X.906)	2	02-6802-08	02-6802-08
19	Piston, Inner, P2	2	02-3751-01	02-3751-01
<b>20</b>	<b>Diaphragm, Back-Up, Neoprene</b>	<b>2</b>	<b>02-1060-51</b>	<b>02-1060-51</b>
<b>21</b>	<b>Diaphragm, Primary</b>	<b>2</b>	<b>02-1010-55</b>	<b>02-1010-55</b>
22	Piston, Outer, P2	2	02-4600-21-500	02-4600-21-500
23	Chamber, Liquid, Adv	2	02-5005-21	02-5005-21
24	Manifold, Inlet, ANSI <sup>2</sup>	1	02-5090-20	02-5090-21
25	Manifold, Discharge, ANSI <sup>1</sup>	1	02-5030-20	02-5030-21
<b>26</b>	<b>Ball, Valve, PTFE</b>	<b>4</b>	<b>02-1085-55</b>	<b>02-1085-55</b>
<b>27</b>	<b>Seat, Valve, Bolted, Poly</b>	<b>4</b>	<b>02-1125-20</b>	<b>02-1125-21</b>
<b>28</b>	<b>O-Ring (1.859 X.139)</b>	<b>4</b>	<b>02-1220-60</b>	<b>02-1220-60</b>
<b>29</b>	<b>O-Ring (2.734 X.139)</b>	<b>4</b>	<b>04-1300-60-500</b>	<b>04-1300-60-500</b>
30	Washer, Flat, 5/16	32	02-6731-03	02-6731-03
31	Screw, HHC, 5/16-18 X 1.50	16	02-6181-03	02-6181-03
32	Screw, HHC, 5/16-18 X 2	16	02-6191-03	02-6191-03
	Muffler, 1/2"(not pictured)	1	02-3510-99	02-3510-99

\* Refer to corresponding elastomer chart in Section 8

\*\*\* Refer to coil voltage selection chart in Section 8

<sup>1</sup>DIN Flange: Polypropylene = 02-5031-02, PVDF = 02-5031-21

<sup>2</sup>DIN Flange: Polypropylene = 02-5091-02, PVDF = 02-5091-21

All boldface items are primary wear parts.

### Adapter Block Option for A200B

No.	Part Description	Qty.	A200P/PPPP P/N
33	Adapter Block	1	00-2155-20
34	Fitting, Air Inlet	2	00-2170-20
35	Screw, HHC	4	04-6000-03

**Section 9**

**Elastomer Options**

**A200 PLASTIC ADVANCED™ PUMPS**

Material	Color Code	Diaphragm (2) P/N	Valve Ball (4) P/N	Valve Seat O-Ring (4) P/N	Flange O-Ring (4) P/N	Backup diaphragm P/N
Polyurethane	Natural	02-1010-50	02-1085-50	02-1220-50	04-1300-50-500	
Buna-N	Red	02-1010-52	02-1085-52	04-2390-52-700	04-1300-52-500	
PTFE Encapsulated FKM®	None			02-1220-60	04-1300-60-500	
Neoprene	Green	02-1010-51	02-1085-51			02-1060-56
FKM®	Silver	02-1010-53	02-1085-53			
EPDM	Blue	02-1010-54	02-1085-54			02-1060-54 <sup>1</sup>
PTFE®	White	02-1010-55	02-1085-55			
Saniflex™	Off-White	02-1010-56	02-1085-56			02-1060-56 <sup>1</sup>
Wil-Flex™	Orange	02-1010-58	02-1085-58	02-1220-58	02-1370-58	

<sup>1</sup>Saniflex™ and EPDM back-up diaphragms are available upon request. Please consult your local distributor.

**Solenoid-Operated Valve Assembly Options** (Consists of Valve Body, Coil and Connector)

Pump Models Designating Specialty Code #	Part Number	Description
150	02-2000-99-150	24V DC Valve Assembly
151	02-2000-99-151	24V AC / 12V DC Valve Assembly
153	02-2000-99-153	24VAC/12VDCValveAssembly(Nema7)
154	02-2000-99-154	24V DC Valve Assembly (Nema 7)
155	02-2000-99-155	110V AC Valve Assembly
156	02-2000-99-156	110V AC Valve Assembly (Nema 7)
157	02-2000-99-157	International 24V DC Valve Assembly1

**Item 1 Main Valve Body Options**

Part Number	Description
02-2000-01-150	Main Valve Body
02-2000-01-154	Main Valve Body (Nema 7)

**Item 2 Coil Options**

Pump Models Designating Specialty Code #	Part Number	Description
150	00-2110-99-150	24V DC Coil
151	00-2110-99-151	24V AC Coil
153	00-2110-99-153	24V AC, Nema 7 Coil
154	00-2110-99-154	24V DC, Nema 7 Coil
155	00-2110-99-155	110V AC Coil
156	00-2110-99-156	110V AC Nema 7 Coil
157	00-2110-99-157	International 24V DC Coil1

<sup>1</sup>Meets European standards and regulations; CENELEC/PTB File #EX-91.C.2027.

**Notes**

PSG  
22069 Van Buren Street  
Grand Terrace, CA 92313-5651 USA  
P: +1 (909) 422-1730 • F: +1 (909) 783-3440  
psgdover.com



Where Innovation Flows

PSG® reserves the right to modify the information and illustrations contained in this document without prior notice. This is a non-contractual document. 05-2018